

F. E. DUCKHAM.

DELIVERY APPARATUS FOR PNEUMATIC GRAIN CONVEYERS.

No. 522,457.

Patented July 3, 1894.

FIG. 1.

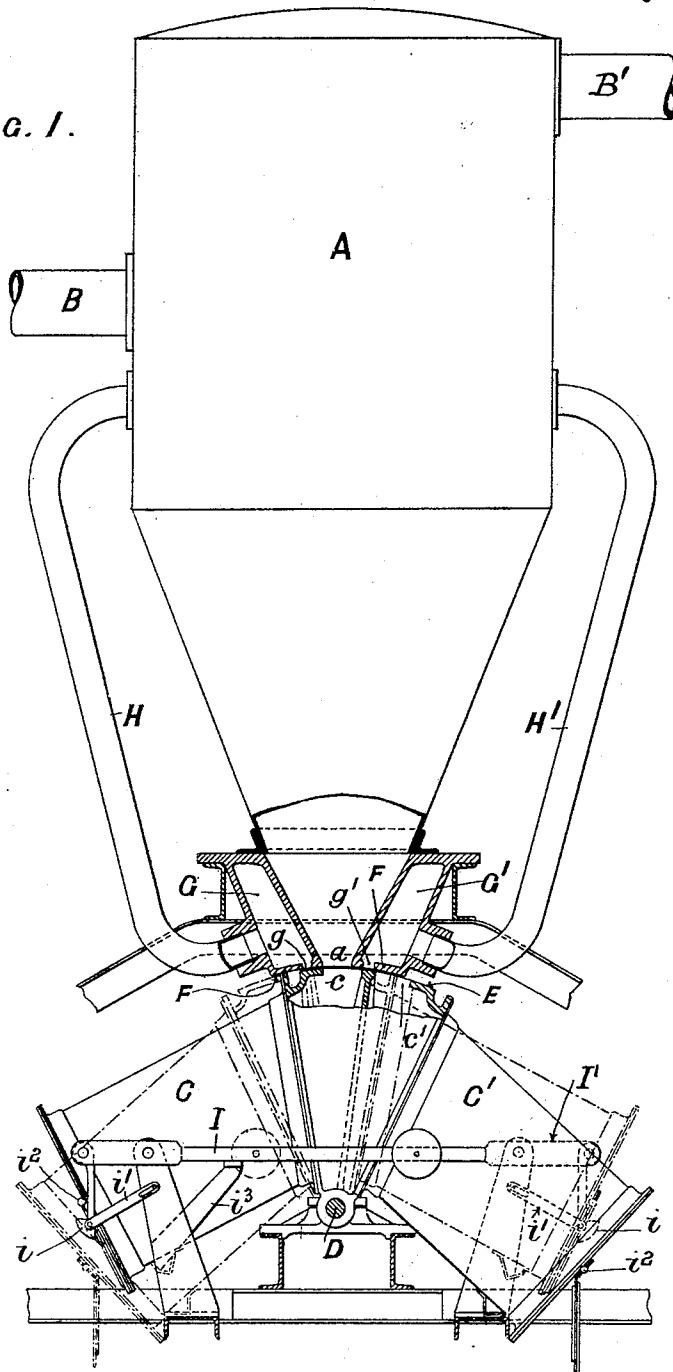

WITNESSES.
C. Sedgwick
J. Munford

INVENTOR:
F. E. Duckham
 BY *Munn & Co*

ATTORNEYS

F. E. DUCKHAM.

DELIVERY APPARATUS FOR PNEUMATIC GRAIN CONVEYERS.

No. 522,457.

Patented July 3, 1894.

FIG. 2.

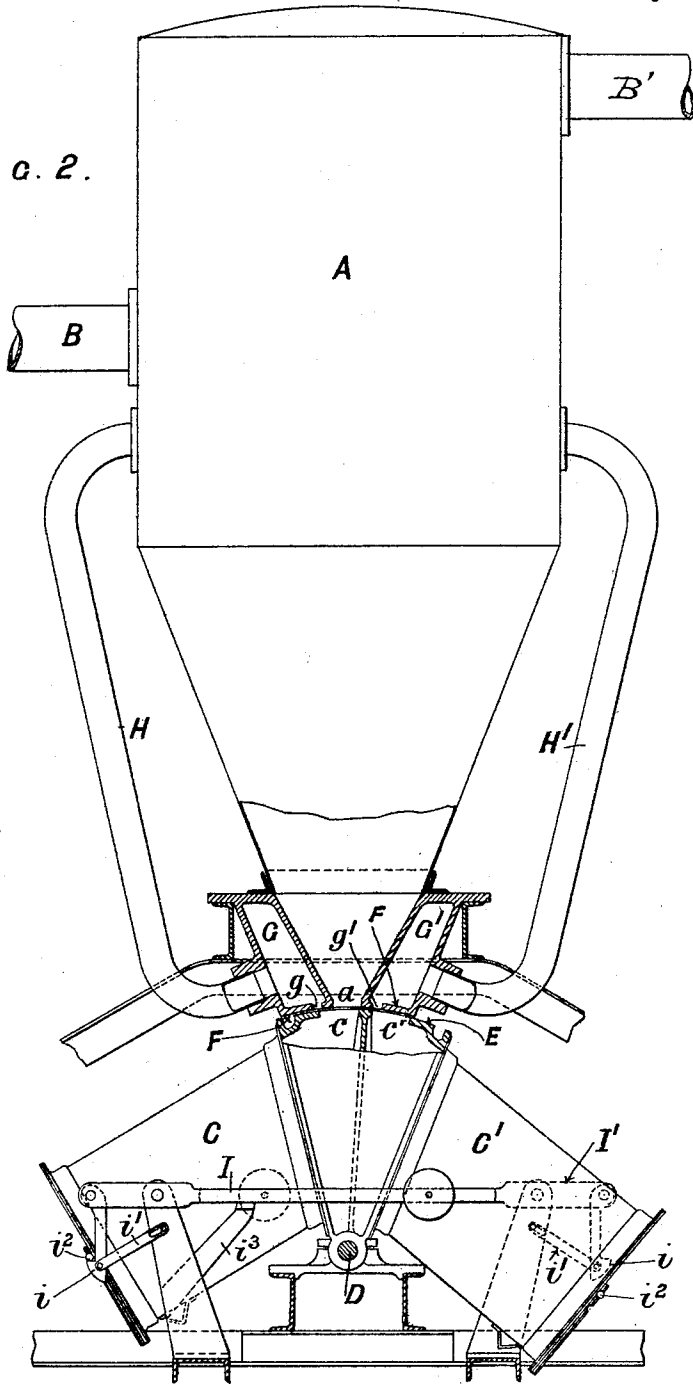

WITNESSES.

W. Sedgwick
J. Mansford

INVENTOR:

F. E. Duckham

BY

Munn & Co

ATTORNEYS.

UNITED STATES PATENT OFFICE.

FREDERIC ELIOT DUCKHAM, OF LONDON, ENGLAND.

DELIVERY APPARATUS FOR PNEUMATIC GRAIN-CONVEYERS.

SPECIFICATION forming part of Letters Patent No. 522,457, dated July 3, 1894.

Application filed December 14, 1893. Serial No. 493,696. (No model.) Patented in India October 23, 1893, No. 263.

To all whom it may concern:

Be it known that I, FREDERIC ELIOT DUCKHAM, civil engineer, of Millwall Docks, London, England, have invented new and useful Improvements in Pneumatic Apparatus for Elevating and Conveying Grain and other Matters, (for which I have obtained Letters Patent in the following country, namely: British India, dated October 23, 1893, No. 263,) of which the following is a full, clear, and exact description.

My invention relates to pneumatic apparatus for loading, unloading, and transferring grain and other granular or pulverulent matters in bulk by an exhaust current of air, and consists of an improvement in the oscillating air-lock delivery box into which the said matters conveyed by the carrying current are deposited and by which they are delivered. Such an air-lock delivery box was described in the specification of former Letters Patent of the United States of America, granted to me and dated the 8th day of March, 1892, No. 470,555, and was therein described as an oscillating twin-chambered receiver. It has been found that as each chamber of the said oscillating air-lock delivery box is brought into position to receive a load, the contained air which replaced the previously discharged load and that which enters the chamber in the act of closing its discharge door, expands through the filling aperture into the exhausted hopper from which the chamber is to be filled, and, by obstructing the passage of the grain or other matters about to enter the chamber of the air-lock delivery box, interferes with the continuous working of the apparatus.

The object of the present improvement is to cause equilibrium of air pressure to be automatically established between the exhausted hopper and the chamber of the said air-lock delivery box which is about to be filled therefrom, before said chamber arrives at the filling position. For this purpose, by-pass passages in permanent connection with the exhausted hopper at a point above the lower conical part thereof communicate with ports in the seat of a valve on the oscillating air-lock delivery box, whereby communication is established between the chamber to be filled and the upper part of the hopper, while the

air-lock delivery box is detained in an intermediate position by the counterweighted latch mechanism by which the periodical oscillation of the delivery box is controlled. By this means the empty chamber is exhausted and its discharge door closed by external atmospheric pressure before said chamber arrives at the loading position and the equilibrium of pressure necessary to the uninterrupted working of the apparatus is established.

Reference is to be had to the accompanying drawings, forming part of this specification, wherein—

Figure 1 is a part sectional elevation of the oscillating air-lock delivery box in its initial position, and Fig. 2 is a similar view of the same apparatus in the second or intermediate position.

The same letters of reference denote like parts in both figures.

A is the hopper wherein is deposited the grain or other matters entering through the conveying pipe B, and to the top of which is connected the air exhausting pipe B' leading to the exhausting engine.

C C' are the chambers of the oscillating air lock delivery box to be alternately filled from hopper A. It rocks on a horizontal axis D and is provided with a valve face E curved concentric to axis D and working air-tight against a correspondingly curved seat F formed around the orifice *a* of the hopper A, the air lock delivery box being supported in position during the filling, and its oscillation in opposite directions being controlled, by appropriate detent mechanisms, each consisting of a counterweighted lever I, a catch *i* dependent therefrom, which engages with a stud *i*², and a slotted link *i*' connected to the catch *i* and to a fixed point for the purpose of withdrawing the catch *i* from engagement with the stud *i*² when the load in the corresponding chamber overcomes the counterweight. So far, the apparatus is similar to that described in my former patent aforesaid.

The means by which equilibrium of pressure is established between the empty chamber C or C' and the hopper A before the aperture *c* or *c*' of said compartment comes opposite the orifice *a* of the hopper A, comprises by-pass chambers G G' (or it may be a single

chamber) in constant communication by pipes H H' with the hopper at a point above the lower conical part thereof A and with ports g g' opening through the valve seat F in such position that when the air lock delivery box is in its extreme position, say, to the right, and the chamber c' is being discharged, as shown in Fig. 1, the port g' of the corresponding by-pass chamber is closed by the portion of the valve face between the inlet apertures c c' of the two chambers, while the aperture c' of chamber C' is uncovered to admit air to said chamber. When, however, the chamber C is loaded to such an extent as to overcome the then emptied chamber C' the air lock delivery box rocks to the left until it is caught by the stud i' at that side resting on the latch i, as in Fig. 2. In this position the aperture c' of the empty chamber C' is closed to the external air and put into communication with the by-pass, port g', whereby the chamber C' is exhausted through G' and pipe H' to the upper part of hopper A thereby causing the discharge door of said chamber to close and establishing equilibrium of pressure between C' and A, so that C' is in readiness to receive a charge immediately on the air-lock delivery box falling over to its extreme position to the left, which is the converse of that shown in Fig. 1. The operation is similar in respect of the other chamber C, the oscillation of the air-lock delivery box in each direction being divided into two stages and the delivery box remaining in the intermediate position until the weight of the load in the chamber being filled overcomes the corresponding counterweighted lever I, thus affording ample time for the establishment of the equilibrium of pressure between the other chamber and the hopper.

In order that the air-lock delivery box may pass quickly from the extreme position to the intermediate position, it is free to move to this extent uncontrolled by the counterweighted detent mechanism, which is prevented by a stop j' from coming into action until the intermediate position is reached.

I claim—

1. In pneumatic apparatus for the conveyance of grain and other pulverulent matters by an exhaust current of air, the combination, with the oscillating two-chambered air-lock delivery box, and the exhausted hopper from which its chambers are filled alternately with the matters deposited in the hopper by the conveying current, of a by-pass air passage or passages in constant communication with the upper part of the exhausted hopper, and a valve controlled by the oscillation of the delivery box, whereby by-pass communication is established between the hopper and the chambers of the air-lock delivery box alternately, so as to establish equilibrium of pressure between the empty chamber and the hopper just before said chamber comes into position to be filled, as specified.

2. The combination with the oscillating

two-chambered air-lock delivery box, and the valve and apertures by which the alternate communication of its chambers with the exhausted supply hopper is controlled, of by-pass ports in the valve seat in permanent communication with the exhausted hopper and situated in such position in the valve seat as to be both closed by the valve when the delivery box is in either of its extreme positions, and put the one or other into communication with the inlet aperture of the chamber about to be filled, when the delivery box is in an intermediate position and the said inlet aperture is closed to the external air, substantially as specified.

3. The combination, with the oscillating two-chambered air-lock delivery box having a valve controlled by the oscillation of a receiver, and apertures by which its chambers are put alternately into communication with an exhausted supply hopper above, and by-pass air ports in said valve seat communicating with the exhausted hopper and controlled by the said valve so as to establish by-pass communication between the hopper and the one or other chamber of the delivery box, at the moment when the delivery box is in an intermediate position, of counterbalanced detent latch mechanism whose operation is so limited as not to oppose the free falling of the delivery box from the extreme to the intermediate position, as specified.

4. In a pneumatic grain-conveying apparatus, the combination of a hopper having a curved valve seat at its discharge end and provided with a chamber on each side, said chambers being provided with ports in their bottoms, pipes leading from the chambers to the hopper, and an oscillating and chambered delivery box having a curved and apertured valve face in contact with the seat of the hopper, substantially as described.

5. In a pneumatic grain conveying apparatus, the combination of a hopper having a curved valve seat at its discharge end and provided with a chamber on each side thereof, said chambers being provided with ports in their bottoms, pipes leading from the chambers to the hopper, an oscillating and chambered delivery box having a curved valve faced top working in contact with the seat of the hopper and provided with apertures leading to the compartments of the box, and a counterbalanced detent latch mechanism for holding the delivery box in position, substantially as described.

Signed by the said FREDERIC ELIOT DUCKHAM.

FREDERIC ELIOT DUCKHAM.

In presence of—

G. F. WARREN,
17 Gracechurch Street, London, Notary Public.

T. W. KENNARD,
Clerk to A. M. & Wm. Clark, Patent Agents,
53 Chancery Lane, London.