

July 5, 1932.

F. GRAY

1,865,516

GLOW DISCHARGE LAMP

Filed Oct. 1, 1926

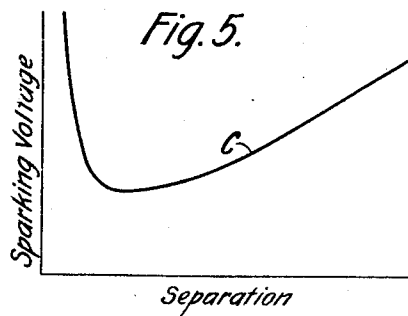
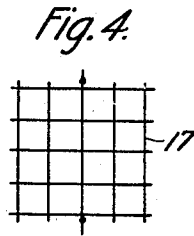
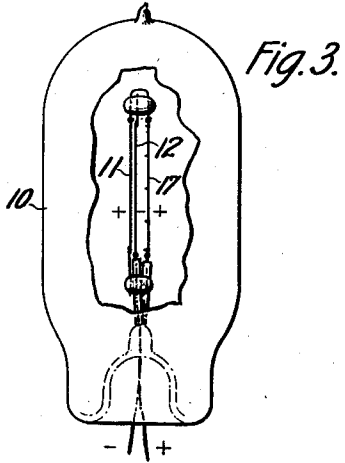
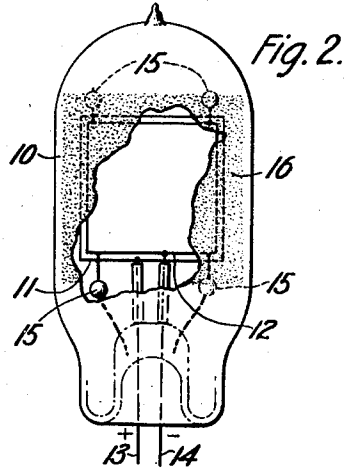
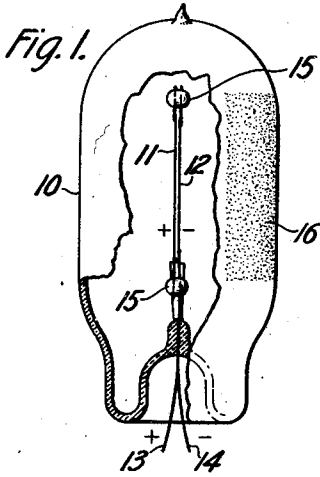

Inventor:
Frank Gray
by *Paul C. Palmer*
Attorney

UNITED STATES PATENT OFFICE

FRANK GRAY, OF NEW YORK, N. Y., ASSIGNOR TO BELL TELEPHONE LABORATORIES, INCORPORATED, OF NEW YORK, N. Y., A CORPORATION OF NEW YORK

GLOW DISCHARGE LAMP

Application filed October 1, 1926. Serial No. 138,831.

This invention relates to a glow discharge lamp, and more particularly to a lamp in which the discharge is confined to one side of the cathode. It is especially suitable for picture reception and television systems.

The general object of this invention is to improve the light emitting qualities of a glow discharge lamp. This object has been attained by confining the glow discharge to one side of the lamp and by causing substantially all of the light produced by the discharge to pass out through the viewing field from an area as large as the viewing field.

This application is a continuation in part of a copending application of Frank Gray, Serial No. 119,550, filed June 30, 1926.

It has previously been proposed to confine the discharge to certain desired portions of the electrodes by covering other portions with insulation. Such a structure is difficult to manufacture and maintain.

According to this invention the glow discharge is confined to one side of the cathode by preventing any discharge within the space between the electrodes by an equivalent insulation between them. Such an equivalent insulation results when two electrodes are positioned at a uniform distance from each other and very close together in a rarified gas. When the electrodes are so positioned the discharge spreads out and over the front surface of the cathode and takes the longer path from the anode around to the far side of the cathode, rather than a much short path across the space between the two plates, with the result that the emission of light takes place principally from the front of the cathode. This phenomenon has been taken advantage of in this invention by positioning the electrodes with a uniform and small separation within a glass bulb containing rarified gas or vapor, such as neon or other suitable gas or combination of gases. When the lamp is in operation the light emitted is substantially proportional to the current flowing therethrough. To render the emitted light more uniform, especially at low intensities, the surface of the bulb opposite the light emitting cathode may be frosted.

In picture reception and television systems, the receiving lamp is usually required to emit light in one direction only and the construction employed in this invention meets this condition by causing substantially all of the light to be emitted from one side or surface of the cathode. This invention is particularly applicable as the receiving lamp in the television system, such as is shown in a copending application of F. Gray, Serial No. 111,731, filed May 26, 1926. With a lamp of this construction used in the receiving device of such a system, the light emitting area is somewhat larger than the viewing field and the image may be viewed without the aid of an optical system and it may be seen through a solid angle of substantially 2π radians.

A more detailed description of the invention follows and is illustrated in the accompanying drawing.

Fig. 1 is a general view of a glow discharge lamp embodying this invention.

Fig. 2 is a front view particularly showing the electrodes of the lamp of Fig. 1.

Fig. 3 is a general view of a modified construction of glow discharge lamp also embodying this invention.

Fig. 4 is a front view of the electrodes of the lamp of Fig. 3.

Fig. 5 is a characteristic curve of the discharge between two parallel plates plotted between sparking voltage and separation between the plates.

The glow discharge lamp shown in Fig. 1 consists of a bulb 10 containing a rarified gas or vapor, a plate anode 11, a plate cathode 12 and positive and negative lead-in wires 13 and 14, respectively. The electrodes may be made of nickel, tungsten, or other suitable material and the cathode may be treated with potassium or other alkaline materials to increase the radiation. The use of a cathode having a polished surface increases the light emissive power of the lamp. Suitable spacing members 15 of insulating material are employed to hold the electrodes in close parallel relationship. The electrodes may be circular or rectangular or any other desired shape and in the preferred form the anode is made slightly larger than the cathode as is

shown more plainly in Fig. 2. The front side 16 of the bulb may be frosted to cause a particularly uniform emission of light over a large area.

5 A modified arrangement of this invention is shown in Figs. 3 and 4. The general construction is similar to that shown in Figs. 1 and 2 with the exception that the anode includes an open grid-like member 17 placed in
10 front of the cathode in addition to the plate anode 11 positioned very close to the rear side of the cathode. The plate anode 11 prevents discharge from the rear side of the cathode in the same manner as in the construction shown in Fig. 1. The grid-like anode 17
15 positioned in front of the cathode is constructed in the form of an open mesh screen with large openings so that it forms substantially no obstruction to the passage of light
20 as more clearly shown in Fig. 4. This grid-like portion 17 of the anode is positioned parallel to and in front of the cathode 12 at a substantially greater distance from it than the plate portion 11, and preferably at the
25 minimum sparking distance for the gas pressure in the tube. The purpose of the grid 17 is to facilitate the distribution of the glow over the front surface of the cathode 12 particularly when the lamp is operated at very
30 low current values.

Curve C of Fig. 5 is a typical curve showing the relationship between the sparking voltage and the separation between parallel plate electrodes at a given gas pressure. This
35 curve shows that as the plates are moved closer together for a certain distance the voltage to produce a discharge directly between the plates becomes less and reaches a minimum sparking distance before they are in
40 contact with each other. If the plates are moved still closer together but not into contact with each other, the voltage required to produce a discharge directly between the plates rapidly increases, and rather than pass
45 across the region between the plates the discharge takes place around the edges of the cathode and over its outer surface. If the plate electrodes are fixed close together and the gas pressure varied the relation between
50 voltage and gas pressure would be quite similar to that shown by the curve C in Fig. 5.

This is substantially in accordance with Paschen's law that the discharge potential depends only upon the product of the gas
55 pressure and the discharge length.

In a particular arrangement of a glow discharge lamp which operated satisfactorily, the lamp contained rarefied neon gas and the plate electrodes were approximately $1\frac{1}{4}$ "
60 long and 1" wide and positioned face to face parallel to each other with a separation of about $\frac{1}{8}$ of an inch. The pressure of the neon gas was between 2 and 5 millimeters of mercury. In the practical manufacture of
65 these lamps the desired characteristics can

be obtained by using two electrodes having a uniform and fixed separation and varying the pressure of the gas.

The electrodes may be flat, cylindrical, spherical or any other desired shape, but
70 should be so positioned with reference to each other, in accordance with the principles set forth above, that the glow discharge is confined to the viewing field.

While this invention has been described
75 as particularly applicable to picture transmission and television systems, it is also applicable to other purposes in which similar requirements are present.

The invention disclosed herein is obviously susceptible to various modifications and adaptations, without departing from the scope and spirit of the invention, and it is not intended to limit the invention to the specific structures herein shown and described, except as defined by the appended
85 claims.

What is claimed is:

1. A glow discharge lamp having a metallic cathode, an anode member, a member positioned parallel to said cathode, and spaced therefrom by a distance less than the minimum sparking distance, whereby said cathode is insulated from the discharge on one side, and means for charging said member
90 positively.

2. A glow discharge lamp comprising an evacuated receptacle, a plurality of continuous plate electrode members within said receptacle in substantially parallel relationship with each other and separated by a distance not greater than that at which the minimum sparking voltage occurs, and electrical connections for impressing an operating voltage across said electrode members, and a
100 translucent screen located on the light emitting side of said members.

3. A glow discharge lamp including a cathode and an anode, said anode comprising a member substantially the same area and size as the said cathode and positioned parallel to and very close to the rear side of said cathode well within the minimum sparking distance and an open grid-like member positioned parallel to and in front of said cathode at a distance equal to at least the minimum sparking distance.
115

4. In a glow discharge lamp, a plate-like cathode member, a plate-like anode member positioned parallel to and very close to the rear side of said cathode member, and an open grid-like anode member positioned in front of the plate-like cathode member and electrically connected to said plate-like anode member.
120

5. A glow discharge lamp including a plate-like cathode member, a plate-like anode member positioned parallel to and very close to the rear side of said cathode member, and another anode member posi-
125 130

tioned in front of the said cathode member and electrically connected to said plate-like anode member.

5 6. A glow discharge lamp including a plate-like cathode member, a plate-like anode member positioned parallel to and very close to the rear side of said cathode member, and another anode member positioned in front of said cathode member, all parts of said
10 second anode member being in front of an imaginary plane extending parallel to and in front of said cathode member at a distance at least equal to the minimum sparking distance, said other anode member being elec-
15 trically connected to said plate-like anode member.

7. A glow discharge lamp including a plate-like cathode member and an anode member, said anode member having a plate-
20 like portion positioned parallel to and very close to the rear side of said cathode member and another portion positioned on the other side of an extended imaginary plane through said cathode and in front of an imaginary
25 plane extending parallel to and in front of said cathode member at a distance at least equal to the minimum sparking distance, said portions being electrically connected.

In witness whereof, I hereunto subscribe
30 my name this 28th day of September, A. D. 1926.

FRANK GRAY.

35

40

45

50

55

60

65