



(11) **EP 2 058 257 B1**

(12) **EUROPEAN PATENT SPECIFICATION**

(45) Date of publication and mention of the grant of the patent:
15.02.2012 Bulletin 2012/07

(51) Int Cl.:
B65H 45/12 (2006.01)

(21) Application number: **08168772.5**

(22) Date of filing: **10.11.2008**

(54) **Leaflet production**

Blattherstellung

Production de feuillets

(84) Designated Contracting States:
AT BE BG CH CY CZ DE DK EE ES FI FR GB GR HR HU IE IS IT LI LT LU LV MC MT NL NO PL PT RO SE SI SK TR

(30) Priority: **08.11.2007 GB 0721918**

(43) Date of publication of application:
13.05.2009 Bulletin 2009/20

(73) Proprietors:
• **Digi Leaflet Technologies Limited**
Nuffield
Henley-on-Thames
Oxfordshire RG9 5SS (GB)
• **Vacuumatic Limited**
Colchester
Essex C04 9QX (GB)

(72) Inventors:
• **Cooper, Michael John**
Colchester, Essex CO3 3QD (GB)
• **Giles, Geoffrey Alan**
Henley-on-Thames, Oxfordshire, RG9 5SS (GB)
• **Colvill, Edward William**
Ipswich, Suffolk IP10 ONX (GB)

(74) Representative: **Gillam, Francis Cyril et al**
SANDERSON & CO.
34, East Stockwell Street
Colchester
Essex CO1 1ST (GB)

(56) References cited:
GB-A- 1 254 850 GB-A- 1 592 879
GB-A- 191 321 575 US-A- 4 136 860
US-A- 4 248 414

EP 2 058 257 B1

Note: Within nine months of the publication of the mention of the grant of the European patent in the European Patent Bulletin, any person may give notice to the European Patent Office of opposition to that patent, in accordance with the Implementing Regulations. Notice of opposition shall not be deemed to have been filed until the opposition fee has been paid. (Art. 99(1) European Patent Convention).

Description

[0001] This invention relates to apparatus for and methods of finishing a leaflet from pre-printed sheet material.

[0002] Most commonly, it is necessary for a product manufacturer to impart information about the product to the end user. Sometimes sufficient information can be carried either on the product itself, but more often the information is printed on the packaging for the product or on a label adhered thereto. Where there is a requirement for a greater amount of information, it is the conventional practice to include a pre-printed information leaflet in the product packaging.

[0003] In the case of pharmaceutical products, country or market legislation requires the manufacturers to give the end users the specific information concerning the products and it is in general not possible to print all of that information on a cardboard carton containing one or perhaps a few blister strips, a tube of ointment or a small bottle of liquid. It is therefore the usual practice to fold a printed sheet, normally made from thin paper and carrying the required information, to a size sufficiently small to be inserted into the carton, along with the pharmaceutical product itself, or to be attached to a bottle containing the pharmaceutical product.

[0004] Rationalisation is creating specialist pharmaceutical manufacturing centres supplying global markets. The variations required to meet local regulations has increased packaging complexity - for example, the same medication may have to be packed to meet a large number of different national requirements, affecting the information leaflet and carton text content. Regulatory authorities are concerned to ensure an ageing population can both read and understand all patient information. More product data, larger type-faces and more user-friendly layouts increase the required space on a product leaflet. Furthermore, some countries require multi-language content which adds yet further pressure on the size of suitable leaflets, sometimes exceeding current information leaflet production capabilities.

[0005] Having regard to the above, there is a demand for leaflets of ever greater usable area but which may be folded down to a relatively small size, for packaging with small products. Further, particularly in the case of pharmaceutical products, it is most important that a leaflet carrying particular information is properly associated with the correct pharmaceutical product and packaging. To this end, it is particularly advantageous if the leaflet can be printed at the time of packaging of a product, so as immediately to be associated with the packaged product. Furthermore, it is also advantageous if the leaflet is in a form which may be adhered to the packaging and then opened out for reading, rather than folded into a shape convenient for insertion into the packaging.

[0006] Existing methods available for producing folded information leaflets, often referred to as "outserts", involve complex set-up procedures which add to the pro-

duction cost and encourage large order volumes which may not reflect immediate demand. This often creates unnecessary packaging waste and affects the leaflet supplier's ability to offer an optimum logistics service.

5 **[0007]** A known leaflet production technique is described in US 4,136,860 (Shacklett). Figures 6 to 9 of Shacklett show a cut sheet of paper pre-printed with the required information repeated on different areas of the sheet. That sheet is then wound around a cylindrical former of circular cross-sectional shape, removed from the former and squeezed into a substantially flat form. The wound sheet is then cut into separate pieces each containing all the required information; thereafter, each wound and squeezed piece may be attached to a carton or bottle. A disadvantage of this process is that the squeezing operation which is performed on the wound sheet causes significant distortion thereof, leading to the formation of unwanted creases. Further, each piece cut from the wound and squeezed sheet must have a significant length (in the direction of the axis of the former) in order to contain the required information in an easily readable form.

15 **[0008]** Though Shacklett (*supra*) described the use of a circular roller, it had been proposed in 1913 to use a winding roller of elliptical shape in a paper-folding machine for the production of a book or a section thereof - see GB21575 A.D. 1913. This was achieved by transversely folding a paper sheet and cutting off the folded edges, to obtain superposed strips of the required size and which were then wound around the elliptical roller, whereafter the wound strips were cut from the roller by means of a knife acting along the roller winding axis. The cut sheets were then further processed as required in the manufacture of a book.

25 **[0009]** In view of the various requirements for producing a leaflet, the present invention aims at providing both an apparatus for and a method of producing an information leaflet from a pre-printed sheet, which leaflet is particularly suitable for use with pharmaceutical products but also useful whenever information leaflets are to be packaged with products.

35 **[0010]** According to one aspect of this invention, there is provided apparatus for producing a leaflet from a pre-printed sheet, comprising a mandrel having an outer surface of generally elliptical cross-sectional shape and gripper means to hold a leading end portion of a sheet advanced to the mandrel, means to effect rotation of the mandrel about the axis thereof to wind an advanced and gripped sheet therearound, and extraction means to remove a sheet wound around the mandrel, characterised in that the sheet is pre-folded along at least one crease line extending in the direction of advancement of the sheet to the mandrel, the extraction means removes the sheet from the mandrel in the axial direction thereof, and compression means is arranged to compress a removed wound sheet into a substantially flat leaflet.

45 **[0011]** According to a second but closely related aspect of this invention, there is provided a method of pro-

ducing a leaflet from a pre-printed sheet, comprising the steps of:

- advancing the sheet to a mandrel having an outer surface of generally elliptical cross-sectional shape and a gripper associated therewith;
- forming at least one crease line to extend in the direction of advancement of the sheet, before the sheet reaches the mandrel;
- using the gripper to hold to the mandrel a leading edge of an advanced sheet;
- rotating the mandrel about the axis thereof so as thereby to wind the advanced sheet around the outer surface of the mandrel;
- axially removing a wound sheet from the mandrel; and
- compressing the wound sheet into a substantially flat leaflet.

[0012] It will be appreciated that a leaflet produced from a sheet in accordance with this invention may have a relatively large printed area and yet be produced in an efficient and rapid manner. As the sheet is wound around a mandrel having a generally elliptical cross-section, the degree of compression of the wound sheet required to produce a flat leaflet is reduced, which in turn reduces the likelihood of a creased or misshapen leaflet, especially when a large information area is required.

[0013] The sheet used for producing the leaflet is pre-printed and may be printed on-line, either immediately or shortly before the sheet is to be folded into a leaflet and associated with a product. The apparatus allows the use of digital printing technologies to pre-print a cut or reel-fed sheet, which is then formed into a leaflet. The leaflet may be applied to a package or carton, immediately following the leaflet formation.

[0014] In the method of this invention, the sheet is pre-folded along at least one crease-line, but preferably along two crease-lines, extending parallel to the direction of advancement of the sheet towards the mandrel. For example, in the case of a cut sheet of A4 size, the creases would extend parallel to the long edges of the sheet and advantageously divide the sheet into three panels of substantially equal area. Such folding of the sheet may be performed by means of a plough folder or other known folding apparatus, to form the fan-folded sheet. Once folded, the sheet may be compressed, for example by a roller nip, fully to form the crease-lines in the sheet. The nip may also perform the function of controlling the feeding of the sheet to the mandrel.

[0015] On winding such a folded sheet around the mandrel, the sheet panel on the mandrel surface will be wound around a smaller radius than the sheet panel furthest from the mandrel, due to the thickness of the sheet. This could tend to form creases in the sheet during the winding operation but to minimise the likelihood of this, it is important that the sheet is both relatively thin and also smooth, so as to have a relatively slippery surface.

To this end, it is preferred for the sheet to be of a thin opaque non-paper material, such as a plastics material, rather than paper as used in the production of traditional leaflets.

[0016] The method of this invention may be performed on cut sheets or on a roll-fed web of sheet material, but in the latter case the material must be cut at some point in the process before winding of the material on the mandrel has been completed, to allow the production of separate leaflets.

[0017] A preferred apparatus has a mandrel with a slot formed therein, and into which the leading edge of the sheet is received. That slot may extend fully across the mandrel, preferably along the major diameter of the generally elliptical cross-section. Within the mandrel, there may be provided a clamping arrangement, for example including a movable gripper finger, arranged to hold a leading edge portion of a sheet received within that slot and thereafter to allow winding of the sheet around the mandrel.

[0018] The wound sheet is removed from the mandrel along the axial direction thereof, either by holding the wound sheet stationary and pulling the mandrel axially out of the wound sheet, or by holding the mandrel stationary and pulling the wound sheet axially off the mandrel. In either case, a pair of endless belts carried on arms movable towards and away from each other and arranged to embrace the mandrel, may be provided for this purpose. Where the mandrel is moved axially out of the wound sheet, those arms may extend in a direction generally normal to the axis of the mandrel. In this case, the belts may also serve to assist the winding of the sheet around the mandrel, by having the belts initially contacting the outer surface of the mandrel, and then contacting the sheet as winding progresses, on rotation of the mandrel. Where the mandrel is held stationary and the wound sheet is pulled off the mandrel, the arms may extend in a direction generally parallel to the axis of the mandrel and remain clear of the mandrel until the wound sheet is to be pulled off.

[0019] In either of the above cases, the belts may define a narrowing gap therebetween, whereby movement of the wound sheet between the belts performs an initial compression of the wound sheet removed from the mandrel. Further compression of that wound sheet into the finished leaflet may be performed by a roller nip furnished at the exit of the narrowing gap of the belts. An adhesive applicator may be provided adjacent the exit of the narrowing gap or the roller nip for performing final compression of the leaflet so as to adhere the free end of the wound sheet to the body of the leaflet.

[0020] By way of example only, two specific embodiments of leaflet producing machine of this invention will now be described in detail, reference being made to the accompanying drawings, in which:-

Figure 1 diagrammatically illustrates the process performed by either embodiment of machine;

Figure 2 is a perspective view of the important parts of the first embodiment of leaflet producing machine arranged to perform the process of Figure 1;

Figures 3 to 7 are side views of the machine of Figure 2, showing the sequence of operation of the machine in producing a leaflet;

Figure 8 is a side view diagrammatically illustrating the important parts of the second embodiment of the leaflet producing machine, also arranged to perform the process of Figure 1;

Figures 9 to 12 are views generally corresponding to that of Figure 8, but showing the sequence of operation of the machine of Figure 8, in producing a leaflet; and

Figures 13A and 13B diagrammatically illustrate two alternative forms of mandrel for use in either of the embodiments.

[0021] Referring initially to Figure 1, the sequence of producing a leaflet in accordance with this invention from a cut sheet of paper or similar thin opaque plastics material will now be described. A cut sheet 10 pre-printed with information is fan-folded, for example by a plough-folding operation, to have two creases 11 extending parallel to the length of the sheet, so as to divide the sheet into three panels 12 of substantially the same shape and area. The sheet may instead be folded by other known processes, such as roll-folding, to have a required folded format. The folded sheet 13 is passed through a roller nip 14 so as fully to form the creases 11 and also to control feeding of the folded sheet 13 towards a mandrel 15.

[0022] In this embodiment, the mandrel 15 has a regular elliptical shape as shown in Figure 1, with a slot 16 extending through and perpendicular to the major axis of the elliptical shape. A clamping device is provided within the slot in the mandrel so as to permit the gripping of the leading edge of a folded sheet 13 fed into the slot 16, by the roller nip 14. The mandrel is mounted for rotation about its geometric centre, in a timed relation to the feeding of a folded sheet into the slot 16, such that when the leading edge 17 of a folded sheet 13 has been fed sufficiently into the slot 16 and then clamped there, the mandrel is rotated so as to wind the folded sheet around the outer surface of the mandrel.

[0023] Once the full length of the folded sheet has been wound round the mandrel 15, the wound sheet 18 is slid off the mandrel in the axial direction thereof and is squeezed to form a flattened coil 19. That coil is then passed through a further roller nip 20 to form creases in the flattened coil and so result in the finished leaflet 21, ready for application to a product.

[0024] Figure 2 diagrammatically illustrates a machine arranged to perform the above process steps, and Figures 3 to 7 show those processing steps performed by the machine and corresponding to the steps shown in Figure 1. A guide 23 for a pre-printed folded sheet leads to the roller nip 14 having a fixed roller 24 and a moving

roller 25 spring-urged into engagement with the roller 24. A stepper motor drive (not shown) is provided for the fixed roller 24 in order to control the advancement of a sheet fed into the nip.

[0025] The mandrel 15 is formed in two similarly-profiled parts mounted on a rotatable carrier (not shown), with the slot 16 formed between those parts. A gripper finger 26 is mounted within the lower part (in Figure 2) for movement into and out of the slot 16, towards and away from the upper part, by means of a control arrangement extending through the carrier to an external actuator (also not shown). In this way, the leading edge region of a sheet fed into the slot may be gripped within the slot.

[0026] A pair of arms 28,29 are pivoted to a mount 30 so that the arm ends 31,32 may be moved towards and away from each other with the arms shown in Figure 2 separated to the maximum extent. Each arm carries a pair of belts 33,34 respectively, running around pulleys provided at both ends of each arm and a stepper motor drive (not shown) is provided for each of those pairs of belts. A spring (not shown) is arranged to urge the arm ends 31,32 towards each other and a control mechanism (also not shown) for those arms 28,29 is adapted to hold the arms separated, as shown, or to allow the spring to act on the arms so that the belts 33,34 contact the outer surface of the mandrel.

[0027] Adjacent the mount 30, on the side thereof remote from the arms 28,29, is the further roller nip 20, comprising rollers 35,36. One of those rollers may be fixed with the other spring urged towards the fixed roller, in a manner generally similar to that of roller nip 14. A stepper motor is arranged to rotate the fixed roller, when required.

[0028] The first stage of the operation of the machine of Figure 2 is shown in Figure 3. A pre-printed folded sheet 13 is shown fed through the roller nip 14 into the slot 16 and is being gripped by finger 26, moved to its active position. Once gripped in this way, the arms 28,29 are released so as to be moved towards each other by the associated spring until the belts 33,34 contact the outer surface of the mandrel 15. The mandrel is then rotated so that the fed sheet is wound around the outer surface of the mandrel, with the arms moving apart and closer together as required, to accommodate the changing effective diameter of the mandrel. Figure 4 shows the operation with one full turn on the mandrel, so that the folded sheet is being wrapped around the outer surface of the mandrel.

[0029] Once the folded sheet has fully been wound around the mandrel, the mandrel is moved in the axial direction while the wound sheet 18 is held stationary by the belts 33,34, until the mandrel comes free of that wound sheet 18, as shown in Figure 5. The mandrel itself has not been shown in Figure 5, for the sake of clarity, but it will be understood that the mandrel has been moved in the direction out of the plane of the drawing. The belts 33,34 are then driven to move the wound sheet to the right (in Figure 6) so as to form a flattened coil 19, as the

sheet approaches the exit end of the arms 28,29. Continued operation of the belts feeds the flattened coil 19 between the rollers 35,36 of the further nip 20. As the flattened coil passes through that nip on to an exit guide 37, the coil is creased so as to form the finished folded leaflet, ready for attachment to a product.

[0030] It will be appreciated that the location of the trailing edge of the flattened and creased coil relative to the creases of that coil may be adjusted by controlling the distance within the slot 16 that the leading edge of the folded sheet is fed, before rotation of the mandrel commences. The important requirement is that the folded sheet is gripped by the finger 26 to prevent any significant slippage of the sheet on rotation of the mandrel; it would be possible for the leading edge to project beyond the slot, should the length of the sheet warrant that to have the trailing edge in the required disposition relative to the creases of the coil. Conveniently, the trailing edge of the finished leaflet should project slightly beyond a crease, so as to provide a tab for opening-out the leaflet, once attached to a product.

[0031] Instead of the slot 16 and gripper finger 26, the mandrel may be provided with an alternative gripping arrangement to hold the leading edge of the folded sheet to the outer surface of the mandrel.

[0032] Figures 8 to 12 show an alternative embodiment of machine for producing a leaflet by the process of this invention, but which embodiment eliminates the axial movement of the mandrel following winding of a folded sheet therearound. In this embodiment, the mandrel 15 corresponds to that described above, except that the carrier (not shown) for the mandrel parts is axially fixed. Further, each arm 28,29 is significantly narrower than with the first embodiment and carries only a single belt 33,34. The arms are arranged closely adjacent the carrier for the mandrel and have a width of less than half the axial length of the mandrel, as shown in Figures 8 and 9.

[0033] A pair of removal belts 40,41 are mounted on respective carriers 42,43 to run around end rollers 44,45 rotatably mounted on those carriers. Each carrier is articulated part way between its ends and an idler roller 46 is rotatably mounted at that articulation. A drive arrangement (not shown) is provided for each removal belt 40,41 and a control mechanism (also not shown) is arranged to move the carriers 42,43 with the removal belts 40,41 between their separated position shown in Figure 8 and their removal position shown in Figures 10 and 11, as required during the operation of the machine.

[0034] Mounted between the removal belts 40,41 is a pair of idler belts 48,49 running around respective rollers supported on plates 50, held stationary between the carriers 42,43. A wedge-shaped former 51 is disposed at the end of the plates 50 remote from the mandrel 15 and leads to the further roller nip 20 having rollers 35,36 together with a drive arrangement (not shown). As with the first embodiment, an exit guide 37 is provided downstream of the further roller nip 20.

[0035] The initial operational steps of this second em-

bodiment is as described above, with reference to the first embodiment. Once a folded sheet has been fed into the slot 16 between the mandrel parts and then gripped by the finger 26, the arms 28,29 are released to be moved under the spring force to contact the mandrel (Figure 9). The mandrel is then rotated, so as to wind the folded sheet therearound, as described with reference to the first embodiment, with the arms separating and moving closer as necessary to accommodate the varying diameter of the mandrel, therebetween.

[0036] Once the folded sheet has been fully wound around the mandrel the arms 28,29 are moved apart, clear of the wound sheet, and the carriers 42,43 are moved closer together so that the removal belts 40,41 contact the wound sheet 18. Driving of those removal belts then pulls the wound sheet off the mandrel, to be engaged between the removal belts 40,41 and the idler belts 48,49 (Figure 10). Continued operation of the removal belts pulls the wound sheet to the right (as shown in Figure 11) until the wound sheet starts to overlie the former 51. The rear parts of the carriers 42,43 are then moved closer together as shown in Figure 12 and continued operation of the removal belts 40,41 squeezes the wound sheet 18 into a flattened coil, by the interaction of those belts with the former 51. The squeezed wound coil is then passed through the further roller nip 20, to compress the creases in the flattened coil and form the finished leaflet 21.

[0037] It will be appreciated that from an engineering perspective, the machine illustrated in Figures 8 to 12 would be very difficult to manufacture and special support arrangements would have to be provided for the plates 50 and wedge-shaped former 51. Though an alternative engineered solution would have to be provided for a practical machine, nevertheless the principle of operation is adequately illustrated by this second embodiment.

[0038] Though not shown in the drawings, the machine may include an adhesive applicator provided before the final squeezing by further roller nip 20, to allow sealing of the end part of the wound sheet to the body of the leaflet. This will prevent inadvertent unwinding of the leaflet.

[0039] Figures 13A and 13B are cross-sections through two alternative mandrel designs, for use in either embodiment of machine as described above. The mandrel shown in Figure 13A is substantially as shown in the embodiments of machine as described above and has a shape which is essentially symmetrical about the plane of the slot 16. The mandrel has a back plate 54 mounted for rotation about its axis and supports upper and lower mandrel parts 55,56. The gripper finger 26 is mounted in the upper part 55 on a shaft 57 such that the end of the finger remote from the shaft may be moved into and out of the slot 16. Figure 13A shows the mandrel in its initial and final positions; the entrance to the slot 16 is bevelled at 58 to assist the entry of the leading edge 17 of a sheet 13 to be wound into a leaflet, the folded sheet 13 being fed to the mandrel along an in-feed table 59. Figure 13A

shows a sheet 18 wound fully around the mandrel, ready to be removed therefrom following release of the gripper finger 26.

[0040] Figure 13B shows an alternative form of generally elliptical mandrel, defined by upper and lower mandrel parts 61 and 62 again supported on a back plate 63. The lower part 62 has a relatively small minor radius as compared to the major radius, such that the elliptical shape defined thereby is relatively flat. The upper part 63 in effect comprises a truncated form of the upper part 55 of the mandrel of Figure 13A and defines the maximum minor radius around which the sheet 18 is wound. The advantage of this mandrel is that it is possible to change the lower part 62 for another of a slightly different shape, without disturbing the gripper finger 26 and its associated mechanism. In turn, this allows a different length of sheet to be wound around the mandrel, on each full turn thereof. In this way, the mandrel may readily be adjusted to suit different leaflet lengths.

[0041] In the foregoing description of Figures 13A and 13B, reference is made to the mandrel as having upper and lower parts but this is merely for convenience, having regard to the mandrel as illustrated in those drawings. The mandrel is mounted for rotation about the axis of the back plate 54 though Figures 13A and 13B show the mandrel in its initial and final positions, before commencing the winding of a folded sheet and subsequent to the completion of that winding.

Claims

1. Apparatus for producing a leaflet from a pre-printed sheet (10), comprising a mandrel (15) having an outer surface of generally elliptical cross-sectional shape and gripper means (26) to hold a leading end portion of a sheet advanced to the mandrel, means to effect rotation of the mandrel (15) about the axis thereof to wind an advanced and gripped sheet therearound, and extraction means (28,29; 33,34) to remove a sheet wound around the mandrel, **characterised in that** the sheet is pre-folded along at least one crease line extending in the direction of advancement of the sheet to the mandrel, the extraction means removes the sheet from the mandrel in the axial direction thereof, and compression means (35,36) is arranged to compress a removed wound sheet into a substantially flat leaflet.
2. Apparatus as claimed in claim 1, wherein the sheet (10) is pre-fan-folded with at least two creases (11) extending parallel to the direction of advancement of the sheet towards the mandrel (15).
3. Apparatus as claimed in claim 1 or claim 2, wherein means (14) are provided to compress the sheet along the or each crease-line before the sheet is wound around the mandrel, preferably by means of a roller nip (24,25).
4. Apparatus as claimed in claim 1 or claim 2, wherein the mandrel (15) has a slot (16) formed therein and into which the leading edge (17) of a sheet is received, said slot extending diametrically through the mandrel, and the gripper means (26) preferably being provided within the slot.
5. Apparatus as claimed in any of the preceding claims, wherein the mandrel (15) has a first part (62) of generally semi-elliptical shape and a second part (61) aligned with the first part and of a modified semi-elliptical shape.
6. Apparatus as claimed in any of the preceding claims, wherein the extraction means includes a pair of belts (33,34; or 40,41) disposed one to each side of the mandrel (15) and arranged to contact a sheet (10) being wound around the mandrel, the belts being configured either to pull the wound sheet axially away from the mandrel, or to hold the wound sheet as the mandrel is withdrawn axially away from a wound sheet held by said belts.
7. Apparatus as claimed in claim 6, wherein the belts (33,34; or 40,41) define a narrowing gap therebetween whereby a wound sheet removed from the mandrel (15) is compressed thereby as the wound sheet is advanced by movement of the belts.
8. Apparatus as claimed in any of the preceding claims, wherein the compression means includes a roller nip (20) including a pair of rollers (35,36) between which the wound sheet is advanced.
9. Apparatus as claimed in any of the preceding claims, wherein there is provided means to apply adhesive to the free end of the wound sheet (10) to adhere that free end to the body of the leaflet.
10. A method of producing a leaflet from a pre-printed sheet (10), comprising the steps of:
 - advancing the sheet (10) to a mandrel (15) having an outer surface of generally elliptical cross-sectional shape and a gripper (26) associated therewith;
 - using the gripper (26) to hold to the mandrel (15) a leading edge (17) of an advanced sheet (10);
 - rotating the mandrel (15) about the axis thereof so as thereby to wind the advanced sheet (10) around the outer surface of the mandrel;
 - removing a wound sheet (10) from the mandrel (15); and
 - compressing the wound sheet (10) into a substantially flat leaflet, **characterised in that** be-

fore the sheet reaches the mandrel, at least one crease line is formed in the direction of advancement of the sheet, and further **characterised in that** the wound sheet is removed from the mandrel in the axial direction thereof.

11. A method as claimed in claim 10 and in which the mandrel (15) has a slot (16) extending thereinto from the mandrel outer surface, wherein the leading edge (17) of the sheet (10) is fed into the slot and the holding of the leading edge is performed within the slot.
12. A method as claimed in claim 10 or claim 11, wherein the sheet (10) is fan-folded with at least two creases (11) extending parallel to the direction of advancement of the sheet towards the mandrel.
13. A method as claimed in claim 12, wherein the sheet (10) is compressed along the or each crease-line (11) before the sheet is wound around the mandrel (15).
14. A method as claimed in any of claims 10 to 13, wherein the wound sheet (10) is removed from the mandrel (15) by a pair of power-driven belts (33,34; or 40,41) disposed one to each side of the mandrel and arranged to contact a sheet wound therearound, the belts pulling the wound sheet axially away from the mandrel.
15. A method as claimed in claim 14, wherein the belts (33,34; or 40,41) define a narrowing gap therebetween so that the wound sheet (10) is compressed thereby as the wound sheet is advanced between the belts by the movement thereof.

Patentansprüche

1. Vorrichtung zum Herstellen einer Broschüre aus einem vorgedruckten Blatt (10), umfassend einen Dorn (15), welcher eine äußere Oberfläche von im Wesentlichen elliptischer Querschnittsform und ein Greifmittel (26) zum Halten eines Bereichs einer führenden Kante eines Blattes, welches dem Dorn zugeführt wird, aufweist, Mittel zum Ausführen einer Rotation des Dorns (15) um eine Achse desselben, um ein zugeführtes und gegriffenes Blatt um denselben aufzuwickeln, Extraktionsmittel (28, 29; 33, 34) zum Entfernen eines Blattes, das um den Dorn gewickelt ist, **dadurch gekennzeichnet, dass** das Blatt entlang wenigstens einer Knifflinie vorgefaltet ist, die sich in einer Richtung des Vorschubs des Blattes zum Dorn erstreckt, wobei das Extraktionsmittel das Blatt von dem Dorn in einer axialen Richtung desselben entfernt, und dass ein Kompressionsmittel (35, 36) vorgesehen ist, um ein entferntes, gewickeltes Blatt in eine im Wesentlichen flache Bro-

schüre zu pressen.

2. Vorrichtung nach Anspruch 1, wobei das Blatt (10) mit wenigstens zwei Kniffen (11) zickzack vorgefaltet ist, die sich parallel zur Richtung des Vorschubs des Blattes in Richtung auf den Dorn (15) erstrecken.
3. Vorrichtung nach Anspruch 1 oder 2, wobei ein Mittel (14) vorgesehen ist, um das Blatt entlang der oder jeder Knifflinie zu pressen, bevor das Blatt um den Dorn gewickelt wird, vorzugsweise mittels einer Druckwalze (24, 25).
4. Vorrichtung nach Anspruch 1 oder 2, wobei der Dorn (15) einen Schlitz (16) aufweist, der darin gebildet ist, und in welchen die führende Kante (17) eines Blattes aufgenommen wird, wobei der Schlitz sich diametral durch den Dorn erstreckt und das Greifmittel (26) vorzugsweise mit dem Schlitz versehen ist.
5. Vorrichtung nach einem der vorhergehenden Ansprüche, wobei der Dorn (15) einen ersten Teil (62) von im Wesentlichen semi-elliptischer Form und einen zweiten Teil (61) fruchtend mit dem ersten Teil und einer modifizierten semi-elliptischen Form aufweist.
6. Vorrichtung nach einem der vorhergehenden Ansprüche, wobei das Extraktionsmittel ein Paar von Gurten (33, 34; oder 40, 41) aufweist, die auf jeder Seite des Dorns (15) angeordnet sind und zum in Kontakt kommen mit einem Blatt (10), das um den Dorn gewickelt ist, angeordnet sind, wobei die Gurte dafür konfiguriert sind, entweder das gewickelte Blatt axial weg von dem Dorn zu ziehen oder das gewickelte Blatt zu halten, wenn der Dorn axial von dem gewickelten Blatt, welches durch die Gurte gehalten wird, weg gezogen wird.
7. Vorrichtung nach Anspruch 6, wobei die Gurte (33, 34; oder 40,41) einen engen Spalt zwischen ihnen definieren, wobei ein gewickeltes Blatt, das von dem Dorn (15) entfernt wird, durch sie gepresst wird, wenn das gewickelte Blatt durch die Bewegung der Gurte vorgeschoben wird.
8. Vorrichtung nach einem der vorhergehenden Ansprüche, wobei das Kompressionsmittel ein Druckwalzenpaar (20) mit einem Paar von Walzen (35, 36) aufweist, zwischen denen das gewickelte Blatt vorgeschoben wird.
9. Vorrichtung nach einem der vorhergehenden Ansprüche, wobei ein Mittel vorgesehen ist, um Klebstoff auf das freie Ende des gewickelten Blattes (10) aufzutragen, um das freie Ende an den Körper der Broschüre anzukleben.

10. Verfahren zum Herstellen einer Broschüre aus einem vorgedruckten Blatt (10), umfassend die Schritte von:

- Zuführen eines Blattes (10) zu einem Dorn (15), der eine äußere Oberfläche von im Wesentlichen elliptischer Querschnittsform und einen Greifer (26), der damit assoziiert ist, aufweist;
- Verwenden des Greifers (26) zum Halten einer führenden Kante (17) eines zugeführten Blattes (10) an dem Dorn (15);
- Drehen des Dornes (15) um eine Achse desselben, sodass **dadurch** das zugeführte Blatt (10) um die äußere Oberfläche des Dornes gewickelt wird;
- Entfernen des gewickelten Blattes (10) von dem Dorn (15); und
- Pressen des gewickelten Blattes (10) in eine im Wesentlichen flache Broschüre,

dadurch gekennzeichnet, dass bevor das Blatt den Dorn erreicht, wenigstens eine Knifflinie in die Richtung des Vorschubs des Blattes gebildet wird, und weiter **dadurch gekennzeichnet, dass** das gewickelte Blatt von dem Dorn in axiale Richtung desselben entfernt wird.

11. Verfahren nach Anspruch 10 und in welchem der Dorn (15) einen Schlitz (16) aufweist, der sich darin von einer äußeren Oberfläche des Dornes erstreckt, wobei die führende Kante (17) des Blattes (10) in den Schlitz zugeführt und das Halten der führenden Kante innerhalb des Schlitzes durchgeführt wird.

12. Verfahren nach Anspruch 10 oder 11, wobei das Blatt (10) mit wenigstens zwei Kniffen (11) zickzack gefaltet ist, die sich parallel zur Richtung des Vorschubes des Blattes zum Dorn erstrecken.

13. Verfahren nach Anspruch 12, wobei das Blatt (10) entlang der oder jeder Knifflinie (11) gepresst wird, bevor das Blatt um den Dorn (15) gewickelt wird.

14. Verfahren nach einem der Ansprüche 10 bis 13, wobei das gewickelte Blatt (10) von dem Dorn (15) durch ein Paar von angetriebenen Gurten (33, 34; oder 40, 41) entfernt wird, die an jeder Seite des Dornes angeordnet sind und die zum Kontaktieren eines Blattes, das um denselben gewickelt ist, angeordnet sind, wobei die Gurte das gewickelte Blatt axial weg von dem Dorn ziehen.

15. Verfahren nach Anspruch 14, wobei die Gurte (33, 34; oder 40, 41) einen schmalen Spalt zwischen sich definieren, sodass das gewickelte Blatt (10) **dadurch** gepresst wird, wenn das gewickelte Blatt zwischen den Gurten durch die Bewegung derselben

vorgeschoben wird.

Revendications

1. Appareil pour la fabrication d'un dépliant à partir d'une feuille pré-imprimée (10), comprenant un mandrin (15) ayant une surface extérieure de section globalement elliptique et un moyen de serrage (26) pour tenir la partie bord d'attaque d'une feuille avancée vers le mandrin, un moyen de réaliser la rotation du mandrin (15) autour de l'axe de celui-ci afin d'enrouler la feuille avancée et serrée autour dudit mandrin, et un moyen d'extraction (28, 29; 33, 34) pour retirer une feuille enroulée autour du mandrin, **caractérisé en ce que** la feuille est pré-pliée le long d'au moins une ligne de pli s'étendant dans le sens de l'avance de la feuille vers le mandrin, **en ce que** le moyen d'extraction retire la feuille du mandrin dans le sens axial de ce dernier, et **en ce qu'** un moyen de compression est disposé pour comprimer une feuille enroulée retirée pour en faire un dépliant sensiblement plat.
2. Appareil selon la revendication 1, dans lequel la feuille (10) est pré-pliée en accordéon avec au moins deux plis (11) s'étendant parallèle au sens de l'avance de la feuille vers le mandrin (15).
3. Appareil selon la revendication 1 ou la revendication 2, dans lequel des moyens (14) sont fournis pour comprimer la feuille le long de la ligne de pli ou de chaque ligne de pli avant que la feuille ne soit enroulée sur le mandrin, de préférence au moyen d'un dispositif de pressage à rouleaux (24, 25).
4. Appareil selon la revendication 1 ou la revendication 2, dans lequel le mandrin (15) possède une fente (16) formée dans celui-ci et dans laquelle le bord d'attaque (17) d'une feuille est reçu, ladite fente traversant diamétralement le mandrin, et le moyen de serrage (26) étant de préférence placé à l'intérieur de la fente.
5. Appareil selon l'une quelconque des revendications précédentes, dans lequel le mandrin (15) possède une première partie (62) de forme globalement semi-elliptique et une deuxième partie (61) alignée avec ladite première partie et ayant la forme d'une semi-ellipse modifiée.
6. Appareil selon l'une quelconque des revendications précédentes, dans lequel le moyen d'extraction comporte une paire de courroies (33, 34; ou 40, 41) disposées une de chaque côté du mandrin (15) et agencées pour rentrer en contact avec une feuille (10) enroulée autour du mandrin, les courroies étant configurées ou pour tirer la feuille enroulée axiale-

ment pour l'éloigner du mandrin, ou pour tenir la feuille enroulée pendant que le mandrin est retiré axialement d'une feuille tenue par lesdites courroies.

7. Appareil selon la revendication 6, dans lequel les courroies (33, 34; ou 40, 41) définissent un écartement qui se rétrécit entre elles et par lequel une feuille enroulée retirée du mandrin est avancée par le mouvement des courroies. 5
8. Appareil selon l'une quelconque des revendications précédentes, dans lequel le moyen de compression comporte un dispositif de pressage à rouleaux (20) consistant en une paire de rouleaux (35, 36) entre lesquels la feuille enroulée est passée. 10 15
9. Appareil selon l'une quelconque des revendications précédentes, dans lequel il est fourni un moyen d'application d'adhésif au bord libre de la feuille enroulée (10) afin de faire adhérer ce bord libre au corps du dépliant. 20
10. Méthode de fabrication d'un dépliant à partir d'une feuille pré-imprimée (10) comportant les étapes suivantes: 25
- avance de la feuille (10) vers un mandrin (15) ayant une surface extérieure de section globalement elliptique et un moyen de serrage (26) associé à celui-ci ; 30
 - utilisation du dispositif de serrage (26) pour tenir dans le mandrin (15) le bord d'attaque (17) d'une feuille avancée (10) ;
 - rotation du mandrin (15) autour de son axe afin d'enrouler ainsi la feuille avancée (10) autour de la surface extérieure du mandrin ; 35
 - retrait d'une feuille enroulée (10) du mandrin (15); et
 - compression de la feuille enroulée (10) pour former un dépliant sensiblement plat, 40

caractérisée en ce qu'avant que la feuille n'atteigne le mandrin, au moins une ligne de pli est formée dans le sens de l'avance de la feuille, et caractérisée de plus par le fait que la feuille enroulée est retirée du mandrin dans le sens axial de celui-ci. 45

11. Méthode selon la revendication 10 et dans laquelle le mandrin (15) possède une fente (16) s'étendant vers l'intérieur de celui-ci à partir de la surface extérieure du mandrin, dans laquelle le bord d'attaque (17) de la feuille (10) est introduit dans la fente et le maintien du bord d'attaque est réalisé dans la fente. 50
12. Méthode selon la revendication 10 ou la revendication 11, dans laquelle la feuille (10) est pliée en accordéon avec au moins deux plis (11) s'étendant parallèles au sens de l'avance de la feuille vers le man-

drin.

13. Méthode selon la revendication 12, dans laquelle la feuille (10) est comprimée le long de la ligne de pli ou de chaque ligne de pli (11) avant que la feuille ne soit enroulée autour du mandrin (15).
14. Méthode selon l'une quelconque des revendications 10 à 13, dans laquelle la feuille enroulée (10) est retirée du mandrin (15) par une paire de courroies motorisées (33, 34; ou 40, 41) disposées une de chaque côté du mandrin et agencées pour rentrer en contact avec une feuille enroulée autour de celui-ci, les courroies tirant la feuille enroulée axialement pour l'éloigner du mandrin. 15
15. Méthode selon la revendication 14, dans laquelle les courroies (33, 34; ou 40, 41) définissent un écartement qui se rétrécit entre elles de manière à ce que la feuille enroulée (10) soit avancée entre les courroies par le mouvement de ces dernières. 20

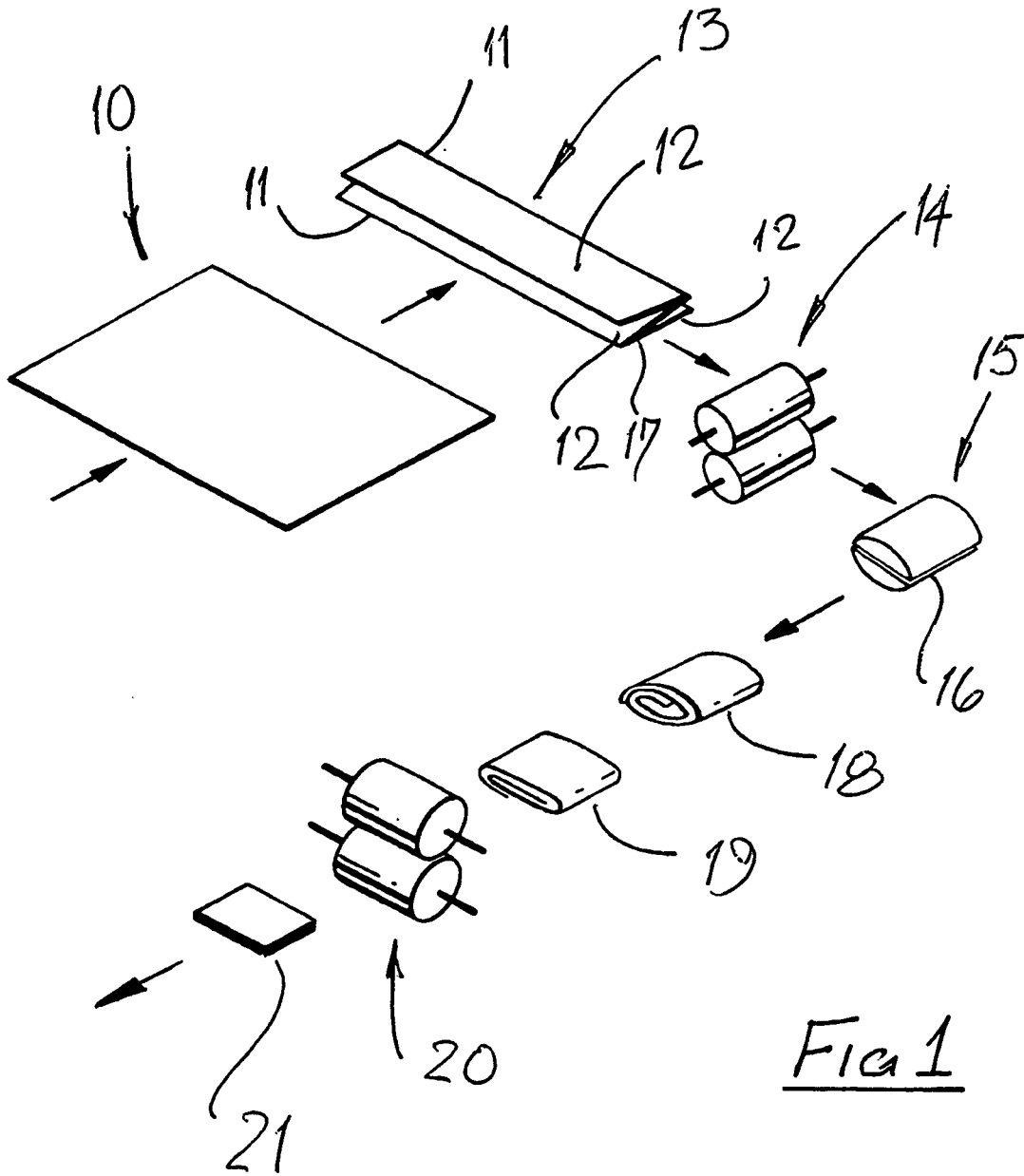

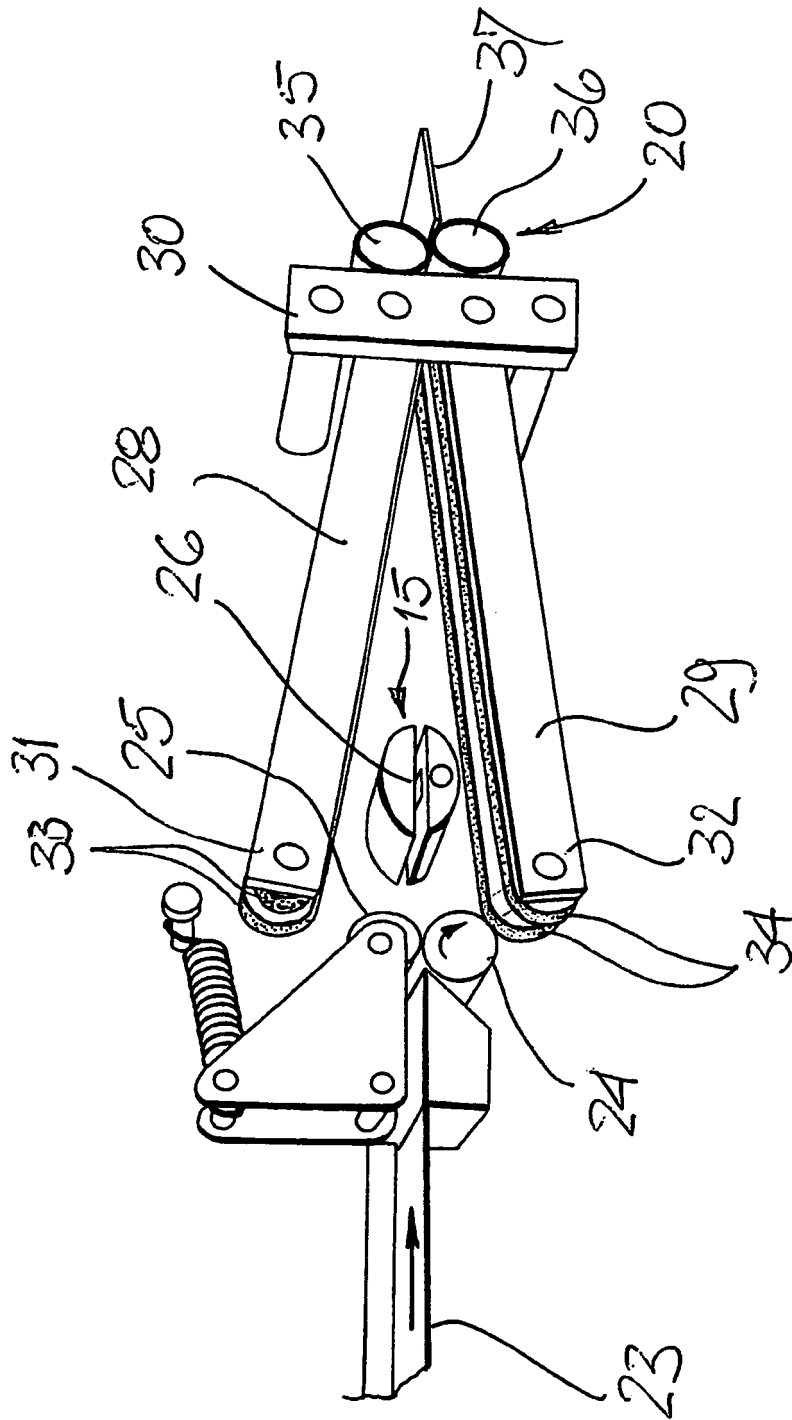
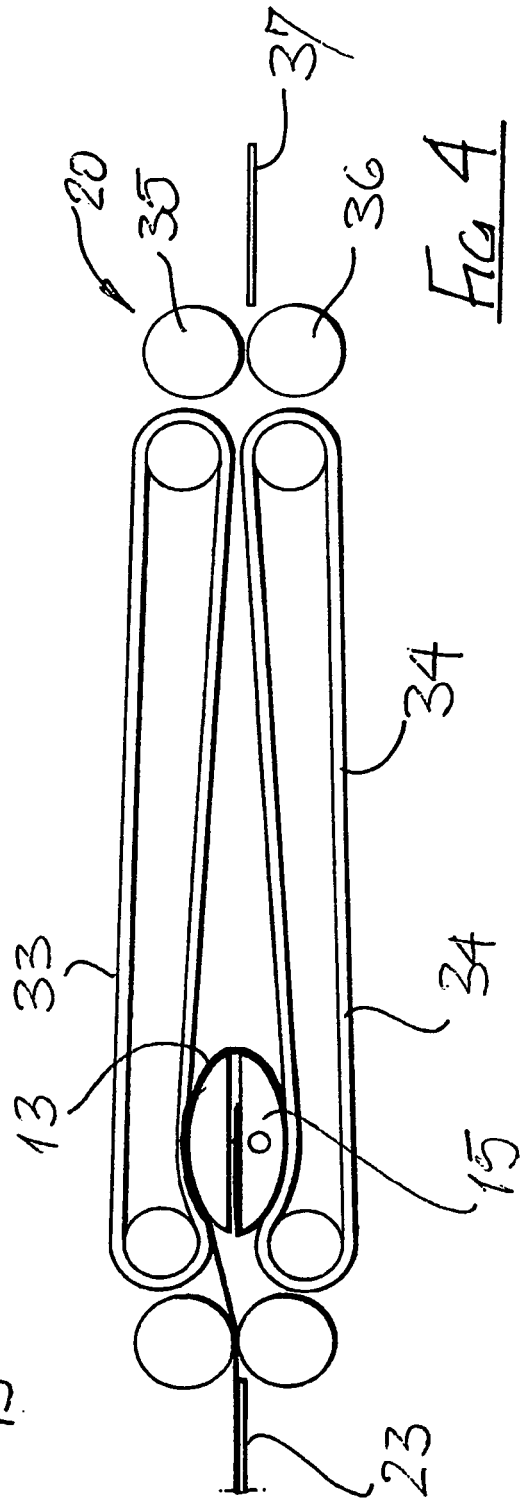
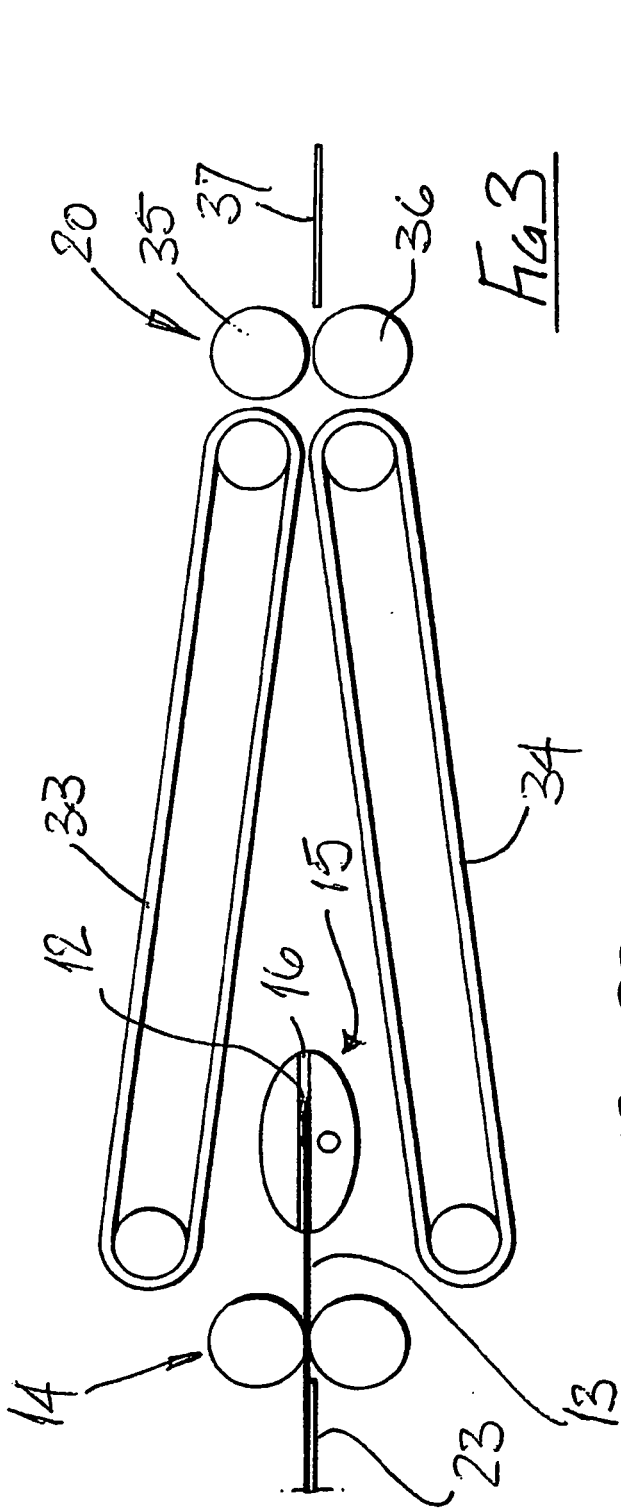
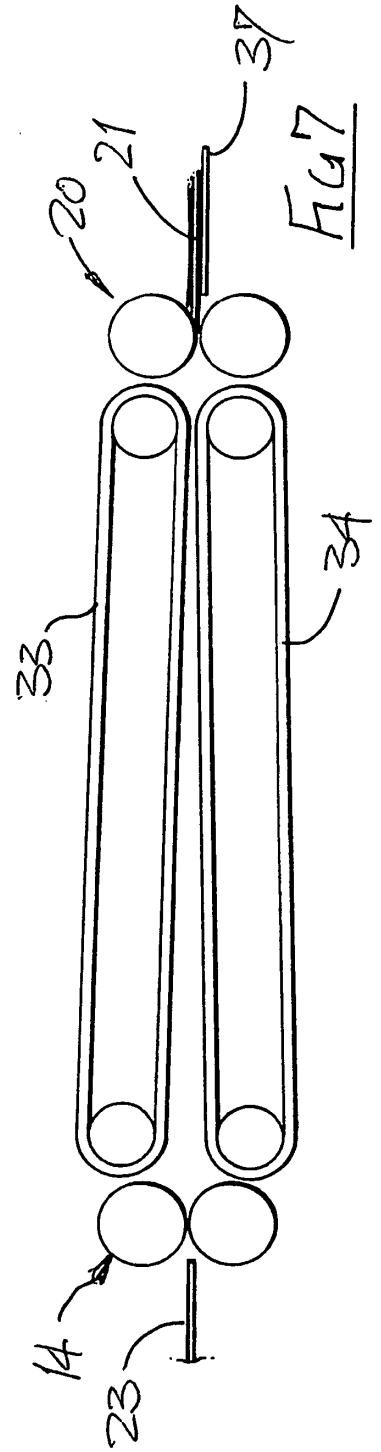
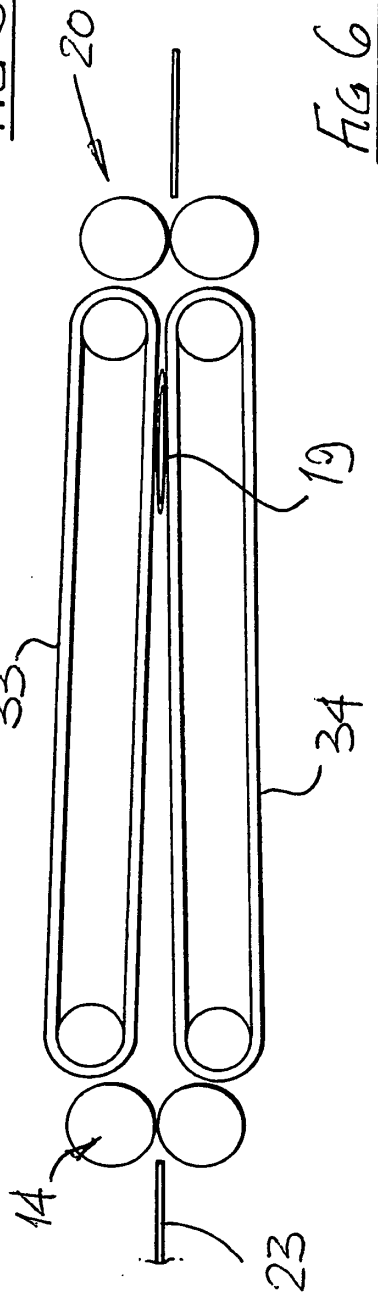
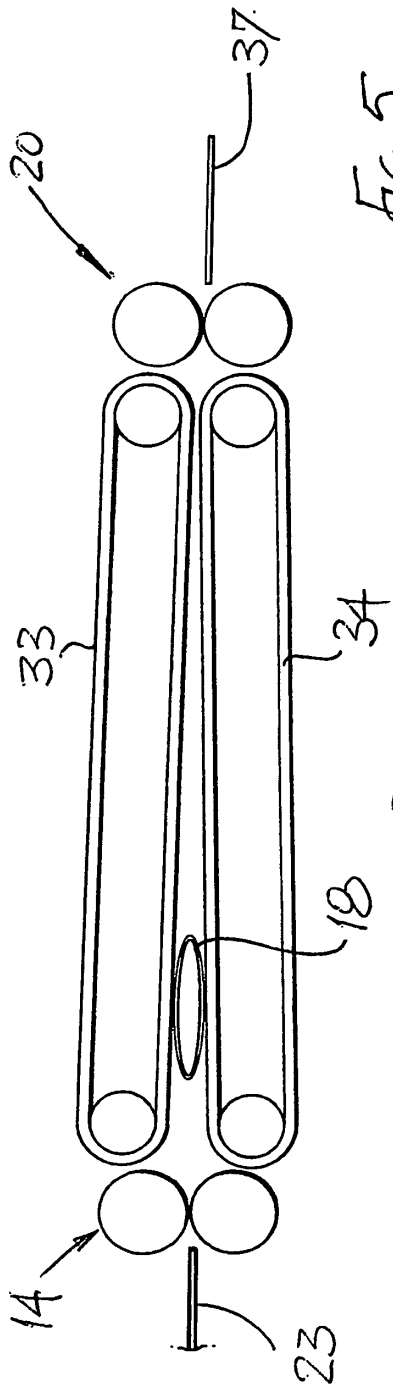
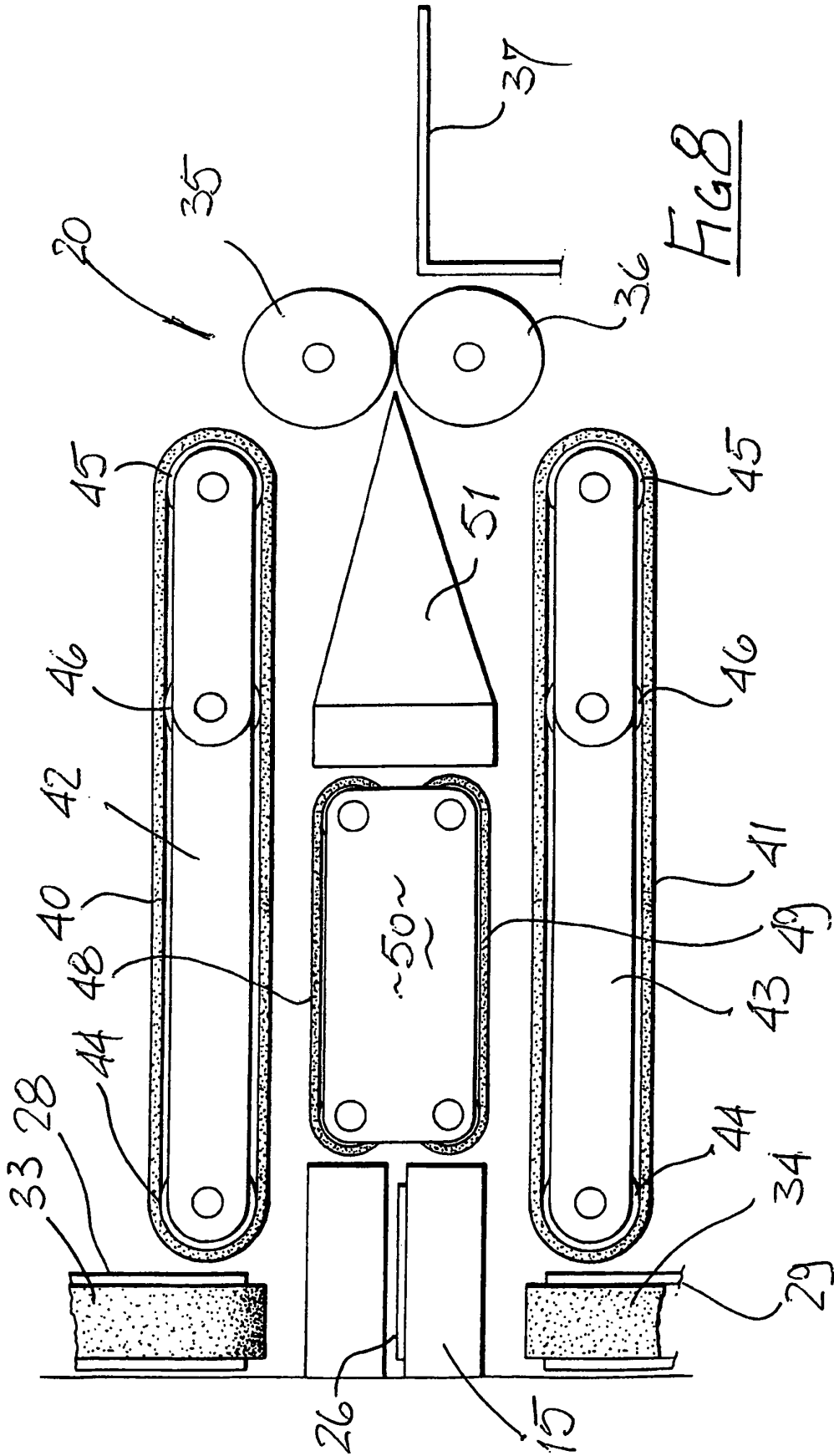

Fig 2







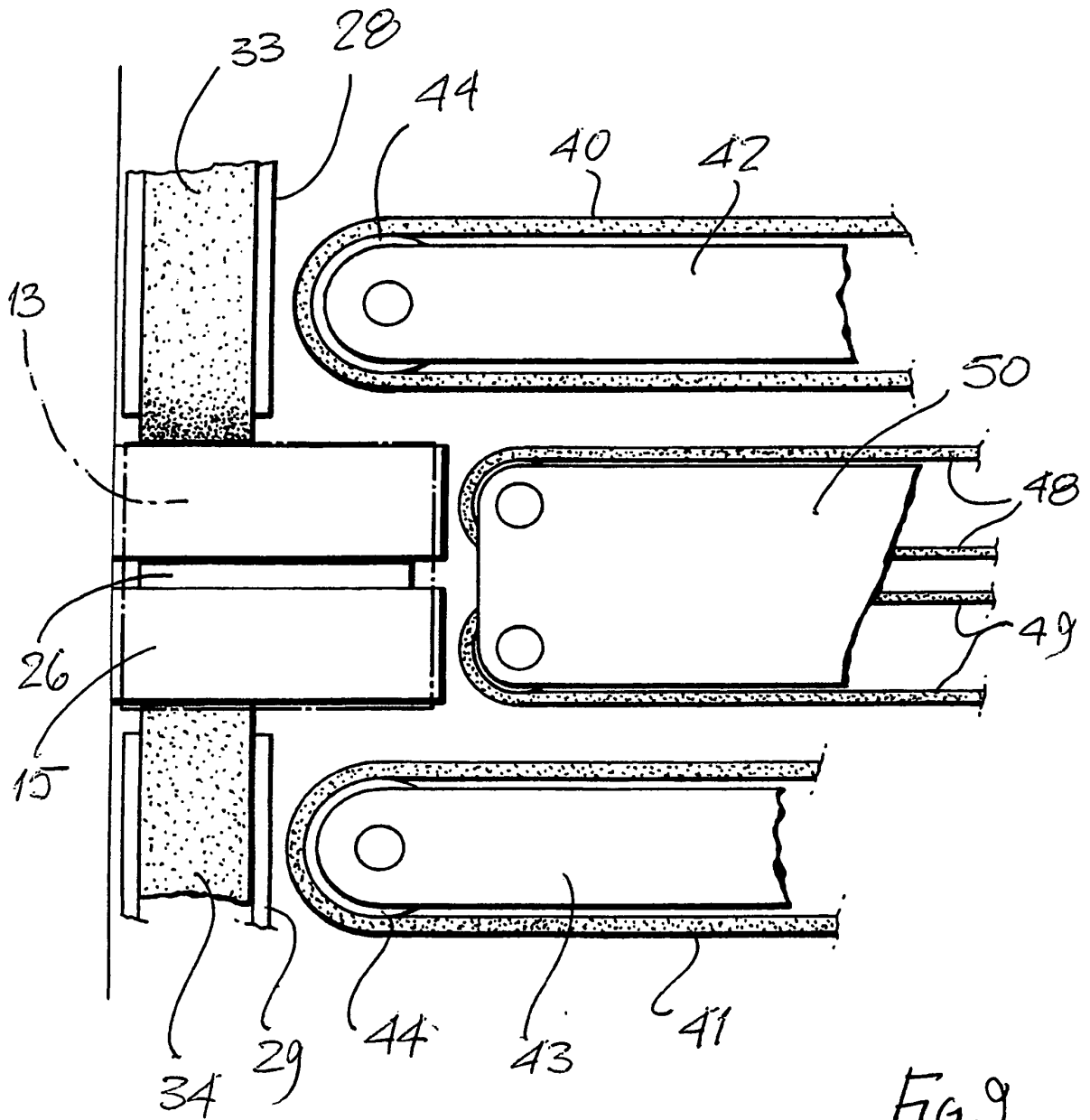

FIG 9

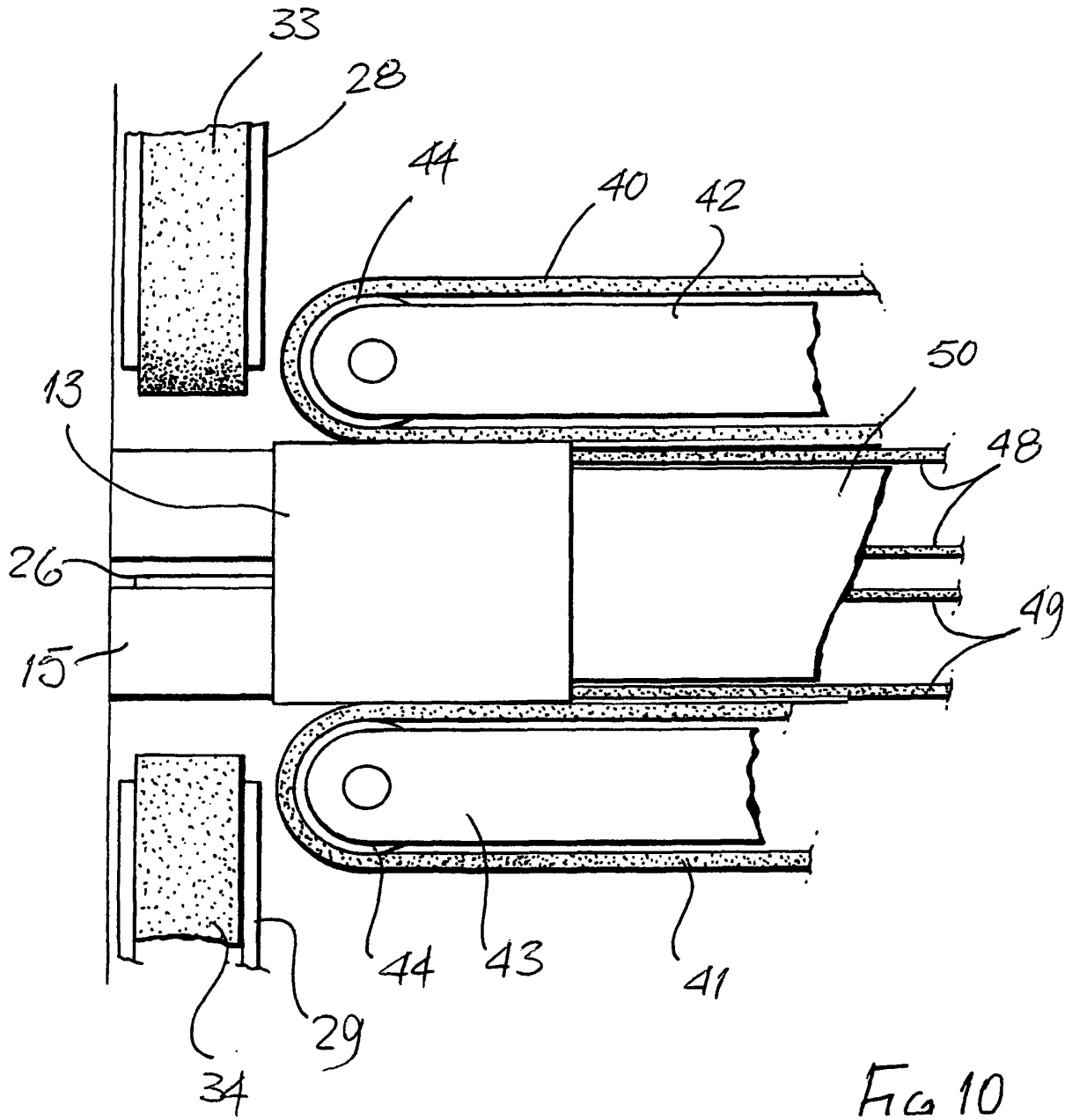

FIG 10

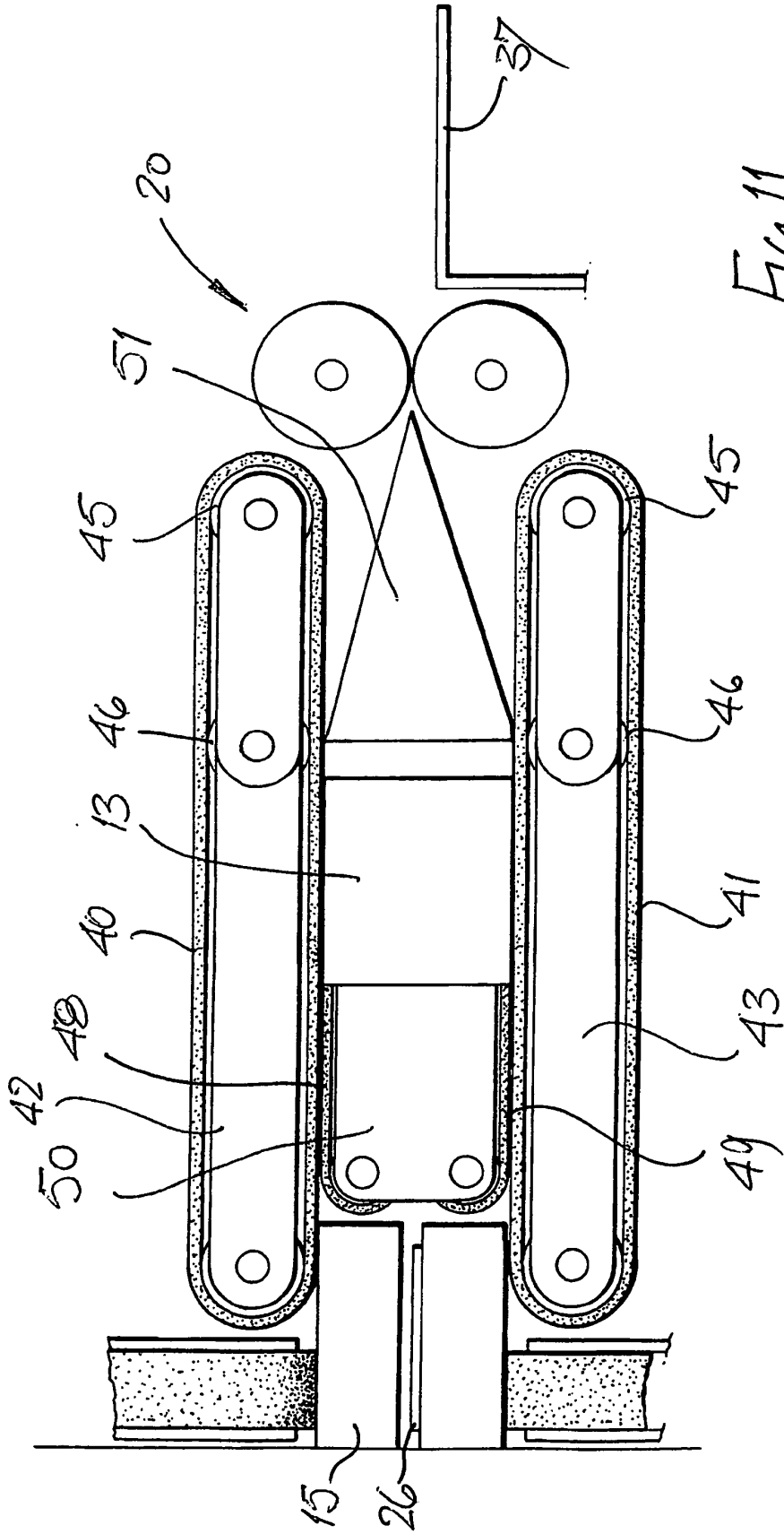

Fig. 11

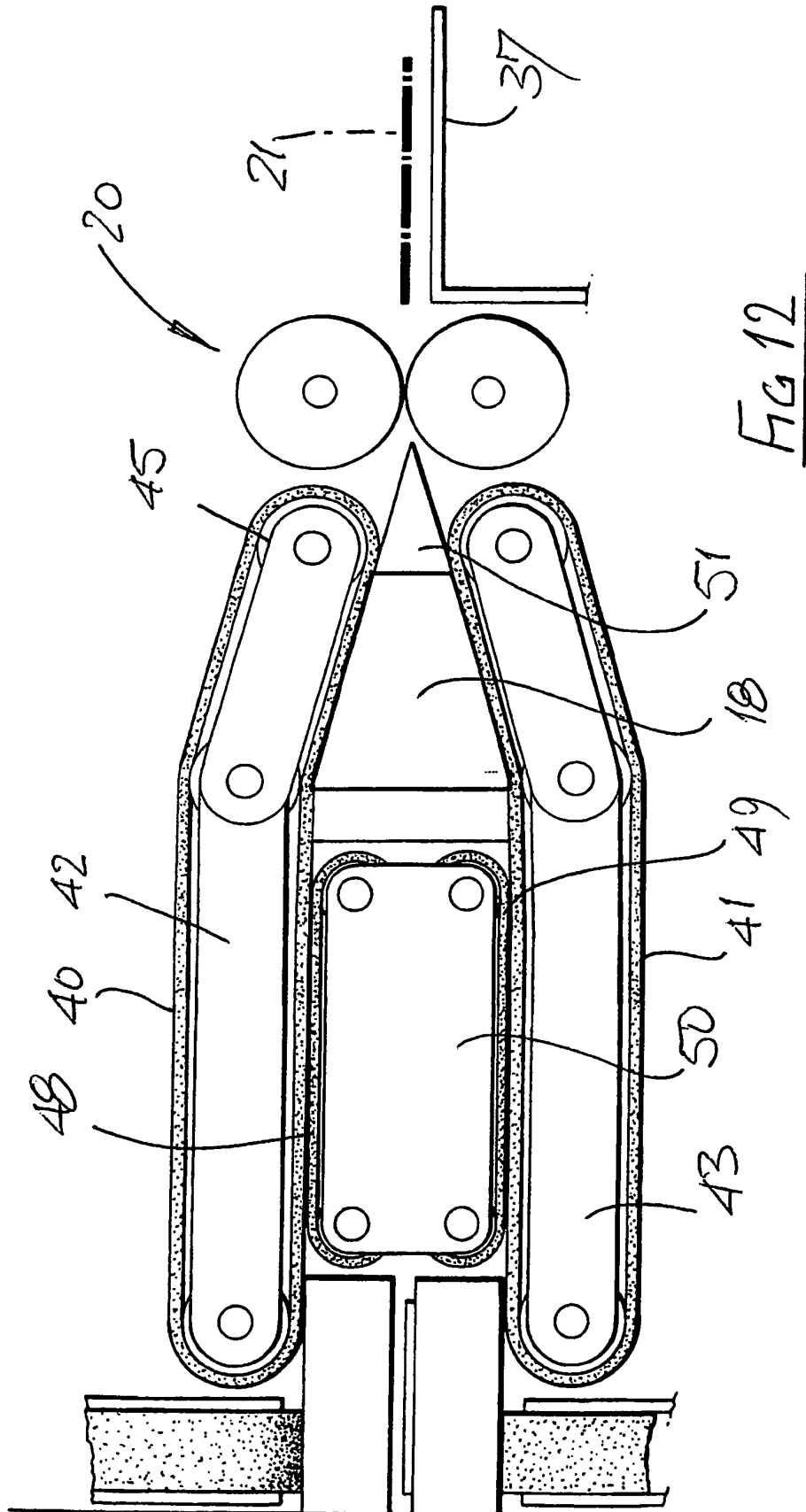
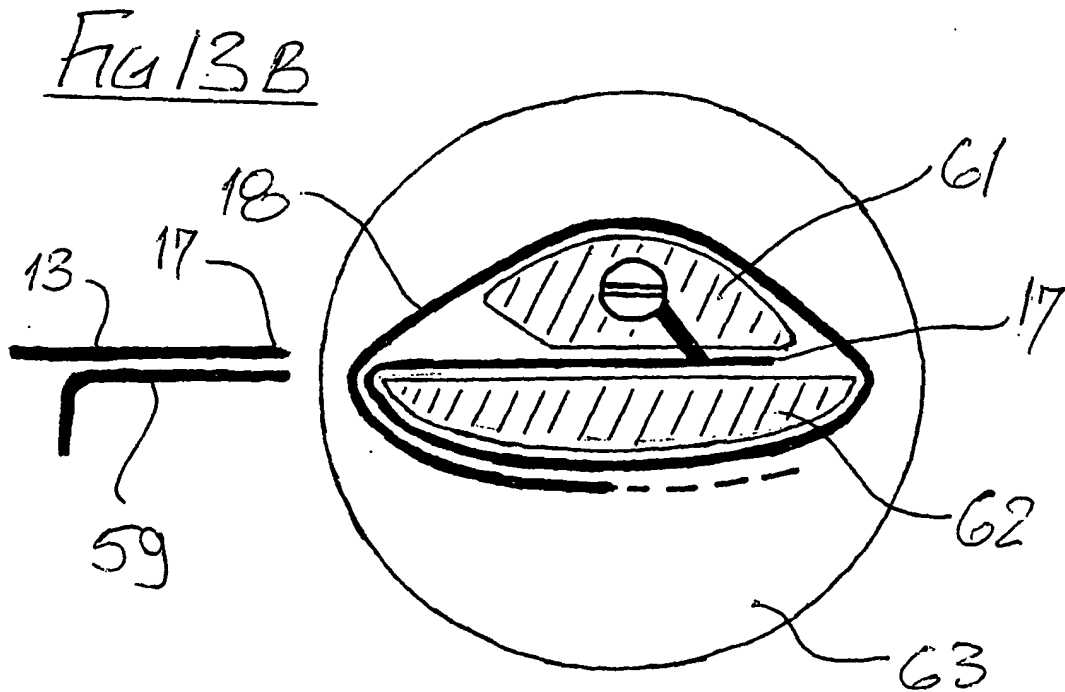
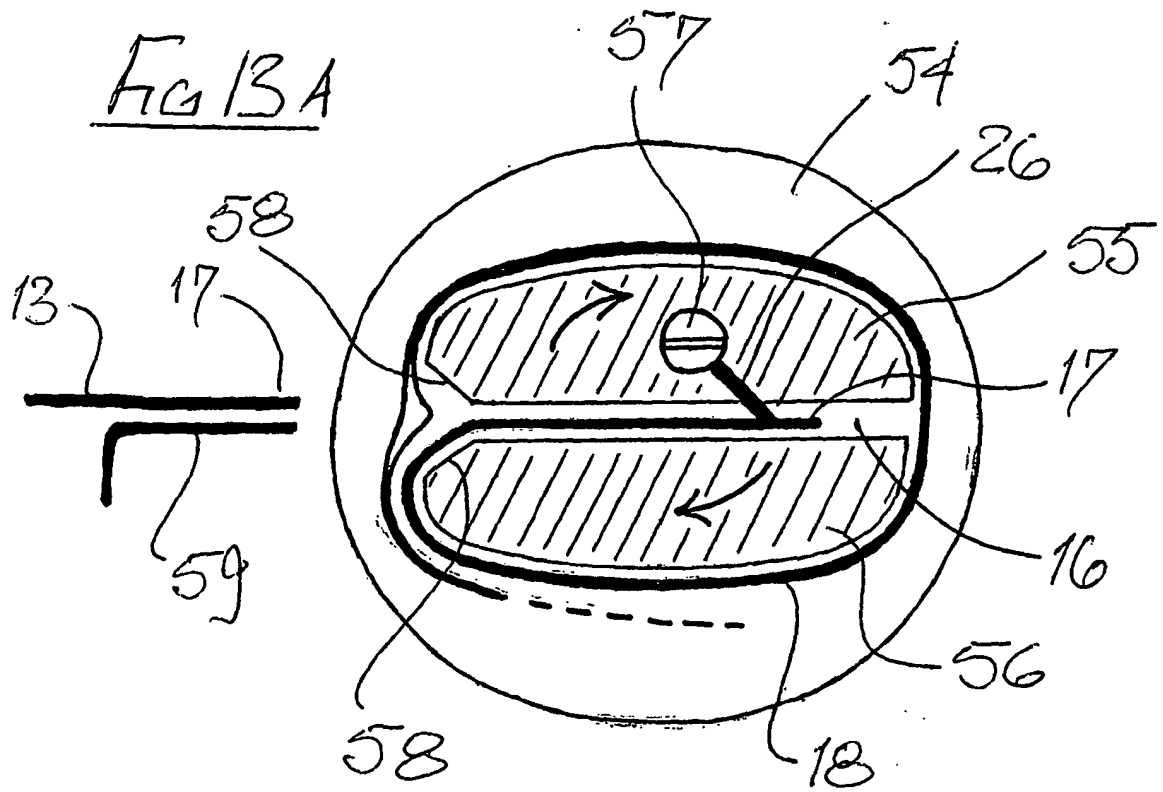

FIG 12



REFERENCES CITED IN THE DESCRIPTION

This list of references cited by the applicant is for the reader's convenience only. It does not form part of the European patent document. Even though great care has been taken in compiling the references, errors or omissions cannot be excluded and the EPO disclaims all liability in this regard.

Patent documents cited in the description

- US 4136860 A [0007]
- GB 21575 A [0008]