



(11) **EP 2 330 352 B1**

(12) **EUROPEAN PATENT SPECIFICATION**

(45) Date of publication and mention of the grant of the patent:  
**27.07.2016 Bulletin 2016/30**

(51) Int Cl.:  
**F24B 1/24<sup>(2006.01)</sup>**

(21) Application number: **10193261.4**

(22) Date of filing: **01.12.2010**

(54) **Fireplace**

Kamin

Cheminée

(84) Designated Contracting States:  
**AL AT BE BG CH CY CZ DE DK EE ES FI FR GB GR HR HU IE IS IT LI LT LU LV MC MK MT NL NO PL PT RO RS SE SI SK SM TR**

(30) Priority: **02.12.2009 FI 20096279**  
**15.04.2010 FI 20105392**

(43) Date of publication of application:  
**08.06.2011 Bulletin 2011/23**

(73) Proprietor: **Nunnanlahden Uuni Oy**  
**83940 Nunnanlahti (FI)**

(72) Inventor: **Lehikoinen, Juhani**  
**83940, Nunnanlahti (FI)**

(74) Representative: **Papula Oy**  
**P.O. Box 981**  
**00101 Helsinki (FI)**

(56) References cited:  
**EP-A2- 1 150 073 EP-A2- 1 376 014**  
**DE-U1-202008 004 705 FI-B1- 120 516**

**EP 2 330 352 B1**

Note: Within nine months of the publication of the mention of the grant of the European patent in the European Patent Bulletin, any person may give notice to the European Patent Office of opposition to that patent, in accordance with the Implementing Regulations. Notice of opposition shall not be deemed to have been filed until the opposition fee has been paid. (Art. 99(1) European Patent Convention).

**Description****FIELD OF THE INVENTION**

[0001] The invention relates to the fireplace defined in the preamble of claim 1.

**BACKGROUND OF THE INVENTION**

[0002] In practice, the fireplaces designated for heating are either heat-storing fireplaces that radiate heat slowly and for a long time, or stoves that radiate heat quickly at over-power. This invention relates predominantly to the stove-type fireplaces and to the improvement of their combustion properties and heating properties.

[0003] Problems in stove-heating arise when wood is tried to be burnt by so-called flameless combustion so as to have a low heating efficiency. In this case, extensive smoke emissions are generated owing to the low combustion temperature, and the flue gases contain compounds that are harmful for health. A stove so used does not fulfill the current regulations concerning emissions. On the other hand, if the stove is burnt quickly, efficiently and purely it radiates heat too quickly and, above all, most of the heat escapes out via the flue.

[0004] The conventional stove is a metal jacket with wood being burnt inside that transfers the heat to the surrounding space. The heating is quick, but there is heat only as long as the fire is burning. The heat of only one metal jacket and the consequent safety risk also constitute a problem. These properties have been tried to be ameliorated by adding around and above the fire box of the stove a heat-storing mass, in general fireproof casting mass, but also suitable natural stone. With these, the heat-storing capacity and heat-release time of the stove have been enhanced, while the temperature of the exterior jacket has been lowered to a safer level. Such a fireplace is known from prior art document EP 1 376 014 A2.

[0005] However, the fact that it has not been possible to transfer the heat energy quickly enough from the flue gases of the stove to the heat-storing masses has still remained as a problem. Also, the size and weight of the fireplace easily become obstacles to a productive solution. The corresponding problems relating to the heat-storage and heat-release are also present in sauna stoves.

**OBJECTIVE OF THE INVENTION**

[0006] An objective of the invention is to eliminate the drawbacks referred to above.

[0007] Especially, an objective of the invention is to disclose a new fireplace structure which encompasses the good properties of a conventional stove that radiates heat quickly, added with pure and complete combustion, durability and good heat-storing and heat-release properties. Furthermore, an objective of the invention is to

disclose a sauna stove with the corresponding good properties.

**SUMMARY OF THE INVENTION**

[0008] The fireplace according to the invention is characterized by what has been presented in claim 1.

[0009] The invention relates to a fireplace including a fire box provided with a grate and a door, surrounded by a fire box jacket and having combustion air supply and a throat to remove the flue gases. Further a vertical metal jacket is disposed after the throat and above the fire box, leading the flue gases upwards. Inside the metal jacket there is a substantially continuous heat-storing mass of a well heat-storing material so as to provide for the formation of flue gas ducts between the metal jacket and the heat-storing mass, the flue gas ducts extending substantially for the entire width and entire height of the mass and the jacket, so that the hot gases rise along the ducts and release the heat partially to the metal jacket and partially to the heat-storing mass. Furthermore, the metal jacket and the fire box jacket are both surrounded by the exterior jacket of the fireplace. The important feature in the invention is that the flue gases around the heat-storing mass are equally hot and that the flue gas flows around the heat-storing mass have an equal volume. This way, the heat-storing mass heats up evenly and its heat-storing capacity is the most efficient. For this purpose, according to the invention in the throat following the fire box where the flue gases of the fire box meet, or immediately after the throat below the heat-storing mass, there are suitable flow guides, such as flaps, a ribbing, channels or an equivalent structure. By these, the hot flue gases can be guided evenly around the heat-storing mass. Also according to the invention in a similar manner, provided above the heat-storing mass are preferably suitable top guides guiding the rising gas flows so that the draft caused by the discharge flue can be distributed evenly around the heat-storing mass.

[0010] The shape of the metal jacket may be a circular cylinder, other round cylinder, it may have a square or a rectangular cross section or it may even be a square with rounded angles. An essential feature is the vertical straight space so that the heavy well heat-storing pieces of mass can be installed and, if necessary, removed from the top.

[0011] The heat-storing mass may even be formed from one solid piece of mass of soapstone or suitable casting mass. Preferably, the heat-storing mass is nonetheless formed by superpositioned slabs, such as suitably soapstone slabs of a uniform thickness, extending for almost the entire horizontal cross section of the inside of the metal jacket. The individual slabs weigh suitably between 5 and 20 kg, depending on the area and thickness of the slabs. In using soapstone slabs and soapstone of a foliated structure, the cleavage of the stone in the slabs may be suitably so chosen that the heat is stored in the slabs efficiently, quickly and simultaneously from all edges.

es toward the center of the slabs.

**[0012]** In the inventive fireplace the thicknesses of the soapstone slabs to be stacked one on the other may vary freely according to the available slabs. Similarly, as the individual slabs of a uniform thickness are disposed

closely against each other, the structure stores the heat well even if some of the slabs therebetween would crack. **[0013]** The cross-sectional shape of the metal jacket and the shape of the heat-storing mass or the separate slabs of the heat-storing mass are not necessarily strictly bound to each other. For example, the individual soapstone slabs of a uniform thickness may be shaped as squares, rounded squares, circles, regular or irregular polygons or they may be irregular at the edges. It is only essential that they fill the interior delimited by the metal jacket to the extent that flue gas ducts are formed between the heat-storing mass and the metal jacket with flow resistances of the same order, disposed relatively evenly for the entire perimeter and height of the interior space. This way, the heat-storing mass heats up evenly everywhere from its edges toward the center throughout the entire heating process. At the same time, the surrounding metal jacket heats up evenly over its entire area and releases heat efficiently and quickly to the outside air. By installing the soapstone slabs suitably one on the other and rotating them to different positions in the plane, a network of smoke ducts with flow resistances of about the same level over the entire circumference can be made to circulate the entire inner surface of the metal jacket. This way, the hot flue gases are distributed evenly over the entire area between the metal jacket and the soapstone slabs to realize as efficient heat transfer as possible.

**[0014]** Preferably, the metal jacket is provided on the top with an opening and tightly closing cover. This provides for easy installation of the heat-storing mass, such as soapstone slabs, and easy and simple cleaning at regular intervals. For example, the stone slabs may be taken out and cleaned and, at the same time, the possibly broken ones may be changed for new. This way, the heat-storing capacity of the fireplace may be easily maintained at the maximum year after year.

**[0015]** In one embodiment of the invention the airspace between the metal jacket and the exterior jacket of the fireplace includes a non-continuous stone jacket having a large heat-storing surface. By a non-continuous stone jacket is meant in this context that the stone jacket is not a compact and continuous stone slab, but is formed from stone mass, i.e. a large set of separate stone pieces which mainly have only a spot contact to each other. A stone mass like this has a large heat transfer surface with air surrounding the stones, notably larger than that of a compact and continuous stone mass.

**[0016]** Preferably, the stone jacket extends above the grate to both sides of the metal jacket, to the back wall, over the door to the front wall and to the cover. Outside the stone jacket, i.e. keeping the stone jacket in place, there is the exterior jacket of the stove. The exterior jacket

may be a gridded structure or suitable perforated plate, so that the heat stored in the stone mass is able to freely flow with air flows to the surrounding airspace. It is also possible that the exterior jacket is a continuous metal sheet. In this case, more heat can be stored in the stone jacket, and by opening and closing the air flow ports on the exterior jacket the surrounding airspace may be heated at different outputs.

**[0017]** In a preferred embodiment of the invention between the metal jacket and the stone jacket there is an air gap arranged to keep the stones of the stone jacket off from the hot metal jacket. This may be realized for only part of the area of the metal jacket, for example for an area where the temperature of the metal jacket is above 500°C. This way, strong point-type thermal stresses on stones are prevented, so that no mineralogical changes are formed therein and the stones can be made to last unbroken.

**[0018]** The stone jacket is preferably located in the fireplace about from the level of the grate upwards, substantially over the entire area of the metal jacket of the fireplace. Its thickness may vary according to the desired heat-storage properties of the fireplace, for example so that the thickness on the vertical walls of the fireplace may be several decimeters. On the top the layer thickness of the stone jacket may instead be preferably at least half a meter and even more than one meter.

**[0019]** In preferred embodiments the stone pieces used in the stone jacket may have a round shape and be of the same or variable sizes. Similarly, they may be irregular sawn or split crushed stone. In any case, they do not have uniform and matching complementary surfaces, so that they mainly have only a spot contact to each other. This way, large numbers of air cavities of different shapes and different sizes are formed between the stone pieces. Correspondingly, the external surfaces of the stone pieces form a large heat-receiving heat delivery surface, compared with a surface formed by a solid stone wall built in the same volume. Thus, the heat-storage capacity and the heat-release capacity of the stone jacket are notably quicker than those of a solid jacket.

**[0020]** When the exterior jacket of the fireplace in the area of the stone jacket is a gridded structure, or the stone jacket is open and visible at least on the top of the fireplace, the fireplace may be used as a sauna stove. On the other hand, the fireplace may have a solid exterior jacket provided only with air flow ports and made of a metal sheet, soapstone slabs, tile or equivalent. In this case, the fireplace is a stove, i.e. it may be used to quickly heat the surrounding room area, but, thanks to the inventive structure, it also stores heat efficiently during heating, which provides for long and steady heat release also after the fire has gone out in the fire box.

**[0021]** Preferably provided below the heat-storing mass, such as the soapstone slabs, is a suitable insulating sheet preventing direct contact of the hottest gases and the combustion process with the lowest soapstone slab. This way, the hottest flames and the combustion

process are not able to directly and too quickly affect the lowest soapstone slab, which has an important effect on the heat-endurance of the lowest slab. This structure also makes it possible that the soapstone used does not necessarily have to be the most resistant and valuable soapstone grade. This way, different kinds of slabs of various thicknesses left over from another manufacturing process may well be used in the fireplace according to the invention.

**[0022]** As can be appreciated from the different structural solutions of the invention as presented above, the quickly and efficiently heat-storing structure according to the invention may be used as a fixed and essential part in different kinds of stoves and sauna stoves. Similarly, it may be used as a retrofitted accessory in various existing stoves.

**[0023]** In one embodiment of the invention an opening and closing damper is provided above the heat-storing mass in the discharge flue for closing the discharge flue and so preventing the hot gas flows to the flue via heat-storing mass after heating. Because the flow path leading from fire box to the flue may nevertheless not be closed completely according to the safety regulations, due to the carbon monoxide hazard, a by-pass duct is provided from the fire box to the discharge flue. It is also preferably linked to the above-mentioned damper in such a manner that as the damper is open the by-pass duct is closed, and as the damper is closed the by-pass duct is open.

**[0024]** In one embodiment of the invention there are suction guides below the heat-storing mass and, respectively, injection guides above the heat-storing mass for distributing the hot chimney gases evenly on the heat-storing surfaces of the heat-storing mass. This way, the negative pressure caused by the draft of the flue sucks the flue gases in the guidance and direction of the suction guides from the fire box via the throat in a controlled way and evenly, distributing heat on all heat-storing surfaces of the heat-storing mass. Similarly, owing to the draft of the flue, the injection guides above the heat-storing mass combine the flue gas flows rising from around the heat-storing mass and align them evenly as parallel flows into the discharge flue. The parallel and converging flue gas flows meet and intensify each other according to the injection principle, this way enhancing the equivalence of the speeds of the flue gas flows from different sides of the heat-storing mass.

**[0025]** Preferably, the suction guide includes horizontal ribs or equivalent blades or planar guides in the horizontal direction for guiding the flue gases under the heat-storing mass in the horizontal direction. The number of the ribs may vary, preferably being 4 to 10. In one embodiment the suction guide includes, in addition to the horizontal ribs, vertical ribs in the area of the throat for guiding the flue gases and limiting their swirling already in the area of the throat, i.e. in the area of the rising motion of the flue gases, so that as they turn to the area of the horizontal ribs they have already been divided into even flows.

**[0026]** Preferably, the injection guide disposed above the heat-storing mass includes horizontal ribs or equivalent blades or guides in the horizontal direction. By these, the flue gases rising from the heat-storage channels onto the heat-storing mass may be collected and directed evenly toward the discharge channel. Since the injection guide also includes parallel vertical ribs suitably in the area of the discharge channel, parallel injection flows can be formed to the discharge channel and therefrom to the flue, intensifying and balancing the flue gas flows of different parts of the heat-storage channel.

**[0027]** In one embodiment of the invention the heat-storage channel includes dividing walls extending from the suction guide to the injection guide to divide the rising heat-storage channel into several separate subchannels. This way, the corresponding horizontal ribs of the suction guide and the induction guide are connected by the dividing walls, so that separate flue gas flow channels extend from the throat to the discharge channel. When the flue gases are divided into subflows and combined from the areas of direct and steady flows in the throat and the discharge channel, a steady and continuous flue gas flow can be provided on all heat-storing surfaces of the heat-storing mass.

**[0028]** The fireplace according to the invention has considerable advantages as compared to the prior art. The same fireplace may be used in a versatile manner in both quick as well as slow and prolonged heating. Thanks to the invention, wood may be burnt in the stove at a high combustion temperature with a high combustion utility function, in which case the stove also produces heat at a high output. To start, the heat can be stored partially in the inventive interior masses and also in the optionally used surrounding stone mass from which it is released steadily or in another desired manner into the room space. Thanks to the construction, the heat-storing masses and the other structures of the stove are not overheated and thus are not subject to a transition temperature where their thermal properties would be weakened, so the stove will keep its quick heat-storing capacity for decades. Furthermore, the same inventive structure in sauna stoves provides for quick and efficient burning of wood as well as prolonged and steady heat.

**[0029]** In addition, the invention provides for even distribution of the hot flue gas flows on all heat-storing surfaces of the heat-storing mass. This way, the entire heat-storing capacity of the fireplace can be efficiently utilized in the invention. Furthermore, the invention provides for as good an overall efficiency as possible in connection with pure and complete combustion.

**[0030]** It may thus be said that the invention has successfully combined the conventional fireplace applicable for quick heating and the massive fireplace having good and quick heat-storing properties with a quick, efficient combustion process according to the modern technology that produces pure flue gases.

## LIST OF FIGURES

**[0031]** In the following the invention will be described in detail by means of examples with reference to the accompanying drawings, in which

Fig. 1 presents one fireplace according to the invention as a schematic sectional illustration,  
 Fig. 2 presents two different embodiments of the invention as a sectional illustration,  
 Fig. 3 presents one detail of the invention,  
 Fig. 4 presents a second detail of the invention, and  
 Fig. 5 presents a third detail of the invention.

## DETAILED DESCRIPTION OF THE INVENTION

**[0032]** Fig. 1 presents one fireplace according to the invention as a sectional illustration, having a grate 1 and a fire box 2 thereon. The fire box is delimited from each side by a close-fitting metal jacket 3 and, naturally, from the front side by the door which is not shown in the sectional illustration. The combustion air supply is provided from below via the grate, and the removal of the flue gases is provided from above in the throat 4, in the top of the fire box.

**[0033]** The metal jacket 3 of the fire box 2 extends upwards after the throat 4, in this embodiment as a metal jacket 5 with a round horizontal cross section, forming a cylindrical space. On top of the space there is an opening and tightly closing cover 11. Disposed in the area of the throat 4, as the space opens into the cylindrical space, are planar suction guides 6 for guiding the hot gas flow rising from the throat and for distributing it evenly over the entire area of the mounting jacket of the cylindrical space. The suction guide 6 includes horizontal ribs 26 and, in the area of the throat 27, vertical ribs 28, which together form dividing walls that guide, delimit and distribute the flue gases to distribute the equally strong and hot flue gases from the steady vertical rising flow of the area of the throat to different sides of the heat-storing mass.

**[0034]** As seen from the embodiment of Fig. 4, the horizontal ribs 26 of the suction guide 6 may form a lattice over the throat 27, extending between the opposed walls or from corner to corner and forming, at the same time, a supporting structure for the stone slabs 7 to be disposed thereon. It is also shown in Fig. 3 and 4 that there may be heat-storing material, such as soapstone slabs, around the metal jacket 5 to increase the heat-storing capacity of the fireplace.

**[0035]** On top of the suction guides 6 there is an insulating sheet 15. The suction guides and the insulating sheet together, or one or the other separately, form a supporting structure or include a separate supporting structure. Disposed on this supporting structure is a set of soapstone slabs 7 of a uniform thickness. Thicknesses between one slab 7 and the other may be different. The slabs extend almost over the entire area delimited by the

metal jacket 5, so that relatively narrow flue gas ducts 8 are formed between them and the metal jacket 5, leading upwards from the fire box. The soapstone slabs 7 may vary in shape, or they may all be similar, for example substantially squares. However, they are preferably disposed, i.e. horizontally rotated, so that the flue gas ducts 8 are formed in a deviously, windingly or for example spirally rising manner between the soapstone slabs and the metal jacket. Furthermore, the flue gas ducts 8 are formed in such a manner that they have substantially equally high flow resistance throughout the entire circumference so as to distribute the flue gases substantially evenly over the entire circumference of the metal jacket 5. The insulating sheet 15 disposed below the soap stone slabs 7 covers the lower surface of the lowest soapstone slab 7 so that the hot and combustible gases circulate to the edges of the soapstone slab. This way, too intensive heating of the lowest soapstone slab is prevented.

**[0036]** Disposed on top of the soapstone slabs 7 are injection guides 10, substantially corresponding to the suction guides 6 at the bottom, for guiding the draft, i.e. the negative pressure, caused by the flue 13 evenly to each side of the heat-storing mass 7. The injection guides 10 include horizontal ribs 29 on top of the heat-storing mass for collecting the flue gases rising around the heat-storing mass to the discharge flue 13. The horizontal ribs 29 extend to the area of the discharge flue 13 as vertical ribs 30 which direct the parallel injection flows of flue gases into the flue.

**[0037]** Outside the fire box jacket 3 and metal jacket 5 described above there is the exterior jacket 9 of the stove. In the embodiment of Fig. 1 the exterior jacket is a solid soapstone slab structure enclosed at the top by the cover 16 of the exterior jacket of the same material. An airspace 17 is formed between the exterior jacket 9 and the fire box jacket 3 and metal jacket 5. The airspace 17 is substantially closed and provided with an inflow valve 18 on the exterior jacket 9 at the bottom of the fireplace and with an outflow valve 19 at the top of the exterior jacket 9.

**[0038]** Furthermore, the structure of Fig. 1 includes a damper 20 installed in the discharge flue 13 for closing and opening it. In addition, a by-pass duct 21 is provided in connection with the operation of the damper. The by-pass duct 21 is a pipe of a relatively small flow cross section that separates from the top of the fire box 2 and runs upwards in the airspace 17 past the metal jacket 5 and the heat-storing mass 7 therein. It is arranged to end above the pivoting axle of the round damper 20 that rotates and hinges on its axle in the discharge flue 13. However, it is so close to the above-said pivoting axle that, when turned vertically, i.e. opened in the flow direction, the damper turns to the front of the by-pass duct 21, closing it. In the embodiment of the figure the surface of the damper 20 is provided with a small baffle or a flange 22 which primarily falls to the front of the mouth of the by-pass duct. When the damper 20 is closed, the by-pass duct 21 opens, letting the possible carbon monoxide gases flow to the discharge flue 13 without the heat of the

heat-storing mass 7 getting into the flue.

**[0039]** This way, in heating the fireplace, part of the heat is stored in the soapstone slabs 7 and part of it is conducted via the metal jacket 5 to the airspace 17 and stored therefrom to the exterior jacket 9 and further to the surrounding room space to be heated more slowly. If quick stove-type initial heating is desired for the fireplace, the valves 18 and 19 may be opened. In this case, a strong rising air flow is formed in the airspace 17 and the heat of the metal jacket 5 is directly transferred to the rising air flow and therewith to the room space.

**[0040]** Fig. 2 presents a second embodiment of the invention, comprising on top of the grate 1 and the fire box 2, in the manner equivalent to the embodiment of Fig. 1, a metal jacket 5, a closing cover 11 and, inside the metal jacket, a set of soapstone slabs 7 of a uniform thickness, the thickness of the individual slabs yet being freely variable. In this embodiment the area of the fire box 2 in the fireplace is made of a heat-storing and fire-proof material, such as soapstone or fire bricks 23.

**[0041]** Fig. 2 is divided in the middle in two different embodiments. In the left embodiment the exterior jacket is a solid metal sheet 24 at the height of the fire box 2 and, upwards therefrom, i.e. in the area of the metal jacket 5, the exterior jacket is a metallic meshwork 25 which extends as far as the top of the fireplace. The gap between the exterior jacket, i.e. the metallic meshwork, and the metal jacket 5 is filled with stone pieces, preferably of soapstone (dicing in the figure), so arranged in shape and positioning that they mainly have only a spot contact to each other and to the metallic meshwork. This way, airspaces are formed between the stone pieces, and the external surfaces of the stone pieces form a large heat-storing area. Furthermore, in this embodiment an air gap 14 is formed in the area of the metal jacket 5 with a suitable mesh structure. This prevents direct contact of the stone pieces with the hottest metallic surfaces of the structure. This way, durability and lifetime of the stones to be used are increased. A cover is not needed at all in this embodiment, but the stone pieces may be visible and bare on the top. In this manner, the fireplace acts as a sauna stove, the visible stone pieces on the outside storing the heat conducted and transferred through the metal jacket 5, while part of it flows to the sauna space with air flows. At the same time, part of the heat developed in the fire box 2 is stored in the heat-storing mass 7 inside the metal jacket 5, from which it is conducted slowly through the metal jacket 5 after the heating has been finished, keeping the sauna in the heated state for a long time.

**[0042]** In the right embodiment of Fig. 2 the exterior jacket 9 is a continuous metal jacket only comprising the inflow valve 18 and the outflow valve 19 according to the embodiment of Fig. 1 to realize even quicker heating of the surrounding airspace. This embodiment corresponds in many respects to a conventional stove provided with a metallic exterior jacket 9, having only an airspace 17 between the interior jacket and the exterior jacket.

**[0043]** This way the stove acts as a quick heating de-

vice as the metal jacket partially radiates and partially conducts heat to the exterior jacket through air. At the same time, it nevertheless also acts, according to the invention, as a heat-release-adjusting and heat-storing structure, realizing a long heating period, storing part of the heat in the heat-storing mass 7 in the middle of the stove. It may therefore be said that the heat which the conventional stove releases in efficient burning out to the smoke flue is stored by this inventive structure in the middle of the stove, releasing it slowly and steadily after heating to the room space. Therefore, the essential feature in the described stove structure is that it may burn wood efficiently and quickly with the best utility function and the modern burning technique that enables pure flue gases. Despite, the stove does not heat up too much during heating, but stores and distributes the heat steadily with a long heating time.

**[0044]** The inventive storing of heat is therefore based on the idea that the heat-storing mass may be relatively continuous and the heat is stored therein through the external surface. When this external surface is further arranged to vary using slabs of different sizes, the heat-exchange surface of the heat-storing mass is made very large. Furthermore, the heat transfer may be intensified according to the embodiment of Fig. 2 by a channel provided through the heat-storing mass, i.e. the soapstone slabs 7 (broken line in the figure). When a gate valve is further disposed in the channel, the channel may be used efficiently for example at the end of heating when the edges of the stone slabs are already very hot. In this manner, the terminal heat may be directly stored in the middle of the stones by opening the gate valve.

**[0045]** Fig. 3 presents one embodiment of the invention that illustrates as a cross-section how the flue gas ducts 8 throughout the entire height of the heat-storing mass 7 comprise dividing walls 31, i.e. metal flanges. They start from the vertical ribs 28 of the suction guide 6 and end at the vertical ribs 30 of the injection guide 10. This way, separate flue gas flow channels are provided around the heat-storing mass 7, starting separately already from the area of the throat 27 and not ending and meeting until at the discharge flue 13.

**[0046]** Fig. 5 presents in more detail one injection guide 10, or respectively, when turned around, one suction guide 6, according to the invention. The injection guide 10 includes a planar horizontal rib 29 or a horizontal blade, the height *a* of which corresponds substantially to the height of the space on top of the heat-storing mass 7 in which it is accommodated. Furthermore, the injection guide includes a planar vertical rib 30 or a vertical blade, the width *b* of which is equal to the radius of the discharge channel 13. The height *c* of the vertical rib is adapted so as to extend from the top of the mass 7 to a sufficient and considerable distance in the discharge channel, but not necessarily to the exterior of the fireplace structure.

**[0047]** If the injection guides 10 are installed according to Fig. 4 from the corners of the space to join in the middle, the lengths *d* of their horizontal ribs 29/12 may be equal.

Various combinations may nevertheless be built from the ribs according to need and welded together in the middle, the number of the ribs and the angles between them varying according to the shapes of the smoke ducts and the necessary flue gas flows. In this case, the lengths of the horizontal ribs 29 vary while the vertical ribs 13 are of the same size in all ribs.

**[0048]** Disposed below the heat-storing mass 7 and in the throat 27, the suction guide according to Fig. 5 extends over the entire horizontal area between the heat-storing mass and the throat and at least over part of the height of the throat, possibly over the entire height of the throat.

**[0049]** This way, equally strong flue gas flows of the same temperature are provided on all heat-storing surfaces of the heat-storing mass 7 throughout the entire heating period of the fireplace. When the heat-storing capacity of the fireplace and the corresponding necessary quantity of wood to be burnt are known, it may be ensured by the invention that the entire heat-storing capacity of the heat-storing mass 7 is utilized and that the by-pass flow of the hot gases to the flue during heating is avoided.

**[0050]** The invention is not limited merely to the examples referred to above; instead, many variations are possible within the scope of the inventive idea defined by the claims.

## Claims

1. A fireplace including a fire box (2) provided with a grate (1) and a door, surrounded by a fire box jacket (3) and having a combustion air supply and a throat (4) for removing the flue gases, after the throat (4) above the fire box (2) there is a vertical metal jacket (5) that leads the flue gases upwards, having a substantially continuous heat-storing mass (7) of a well heat-storing material therein, so disposed that flue gas ducts (8) are formed between the metal jacket and the heat-storing mass and extend substantially for their entire width and entire height, and that the metal jacket (5) and the fire box jacket (3) are surrounded by the exterior jacket (9) of the fireplace, **characterized in that** in the throat (27) or after the throat below the heat-storing mass (7) there are suction guides (6) for guiding the hot flue gases evenly around the heat-storing mass (7), and above the heat-storing mass (7) there are injection guides (10) for distributing the draft of the following discharge flue (13) evenly around the heat-storing mass.
2. The fireplace according to claim 1, **characterized in that** the heat-storing mass (7) is formed by superpositioned soapstone slabs of a uniform thickness, extending almost over the entire horizontal cross section of the inside of the metal jacket (5).
3. The fireplace according to claims 1 or 2, **characterized in that** on the metal jacket (5) there is an opening cover (11) for cleaning and maintenance of the heat-storing mass (7).
4. The fireplace according to claims 2 or 3, **characterized in that** the soapstone slabs (7) are squares, wherein the diagonals correspond to the diameter of the metal jacket (5) of a cylindrical shape, the squares being disposed inside the metal jacket so that the position of the corners vary in order to form devious flue gas ducts.
5. The fireplace according to any one of claims 2 to 4, **characterized in that** the soapstone slabs (7) are variable and irregular at the outer edges.
6. The fireplace according to any one of claims 1 to 5, **characterized in that** outside the metal jacket (5) there is a non-continuous stone jacket (12) having a large heat-storing surface.
7. The fireplace according to claim 6, **characterized in that** between the metal jacket (5) and the stone jacket (12) there is an air gap (14) to prevent direct contact between the stone jacket and the metal jacket.
8. The fireplace according to claim 6 or 7, **characterized in that** the exterior jacket (9) of the fireplace outside the stone jacket (12) is a meshwork, perforated plate or continuous metal sheet, in which case the fireplace is for example a sauna stove.
9. The fireplace according to any one of claims 1 to 7, **characterized in that** the entire exterior jacket (9) of the fireplace is made of a well heat-storing material, such as soapstone or metal sheet.
10. The fireplace according to claim 9, **characterized in that** the fireplace is a stove.
11. The fireplace according to any one of claims 1 to 10, **characterized in that** the suction guide (6) includes horizontal ribs (26) to guide the flue gases under the heat-storing mass (7) in the horizontal direction, and, in the area of the throat (27), vertical ribs (28) to guide the flue gases to the area of the horizontal ribs (26).
12. The fireplace according to any one of claims 1 to 11, **characterized in that** the injection guide (10) includes horizontal ribs (29) above the heat-storing mass (7) to collect the flue gases rising from the heat-storage channels (8) and guide them toward the discharge channel (13), and vertical ribs (30) in the area of the discharge channel to form parallel injection flows in the discharge channel.
13. The fireplace according to any one of claims 1 to 4,

**characterized in that** the flue gas duct (8) includes dividing walls (31) extending from the suction guide (6) to the injection guide (10) to divide the rising flue gas duct into several separate subchannels.

### Patentansprüche

1. Kaminofen, der eine Brennkammer (2) enthält, die mit einem Rost (1) und einer Tür versehen ist, von einer Brennkammer-Ummantelung (3) umschlossen ist und eine Verbrennungsluft-Zufuhr sowie ein Halsstück (4) zum Ableiten der Abgase aufweist, wobei auf das Halsstück (4) oberhalb der Brennkammer (2) eine vertikale Metall-Ummantelung (5) folgt, die die Abgase nach oben leitet, die eine im Wesentlichen durchgehende Wärmespeicher-Masse (7) aus einem gut wärmespeichernden Material in ihrem Inneren aufweist, die so angeordnet ist, dass Abgasschächte (8) zwischen der Metall-Ummantelung und der Wärmespeicher-Masse ausgebildet sind und im Wesentlichen über ihre gesamte Breite und gesamte Höhe verlaufen, und die Metall-Ummantelung (5) sowie die Brennkammer-Ummantelung (3) von der Außen-Ummantelung (9) des Kaminofens umschlossen sind, **dadurch gekennzeichnet, dass** in dem Halsstück (27) oder auf das Halsstück folgend unterhalb der Wärmespeicher-Masse (7) Ansaug-Führungen (6) vorhanden sind, mit denen die heißen Abgase gleichmäßig um die Wärmespeicher-Masse (7) herum geleitet werden, und oberhalb der Wärmespeicher-Masse (7) Einleit-Führungen (10) vorhanden sind, mit denen der Zug des folgenden Abzugkanals (13) gleichmäßig um die Wärmespeicher-Masse herum verteilt wird.
2. Kaminofen nach Anspruch 1, **dadurch gekennzeichnet, dass** die Wärmespeicher-Masse (7) durch übereinander angeordnete Speckstein-Platten einer einheitlichen Dicke gebildet wird, die sich über nahezu den gesamten horizontalen Querschnitt der Innenseite der Metall-Ummantelung (5) erstrecken.
3. Kaminofen nach Anspruch 1 oder 2, **dadurch gekennzeichnet, dass** sich an der Metall-Ummantelung (5) eine zu öffnende Abdeckung (11) zum Reinigen und Warten der Wärmespeicher-Masse (7) befindet.
4. Kaminofen nach den Ansprüchen 2 oder 3, **dadurch gekennzeichnet, dass** die Speckstein-Platten (7) Vierecke sind, wobei die Diagonalen dem Durchmesser der Metall-Ummantelung (5) einer zylindrischen Form entsprechen und die Vierecke so im Inneren der Metall-Ummantelung angeordnet sind, dass die Positionen der Ecken variieren und so gewundene Abgaskanäle gebildet werden.
5. Kaminofen nach einem der Ansprüche 2 bis 4, **dadurch gekennzeichnet, dass** die Speckstein-Platten (7) an den äußeren Enden variabel und ungleichförmig sind.
6. Kaminofen nach einem der Ansprüche 1 bis 5, **dadurch gekennzeichnet, dass** sich außerhalb der Metall-Ummantelung (5) eine nicht durchgehende Stein-Ummantelung (12) befindet, die eine große Wärmespeicherfläche hat.
7. Kaminofen nach Anspruch 6, **dadurch gekennzeichnet, dass** zwischen der Metall-Ummantelung (5) und der Stein-Ummantelung (12) ein Luftspalt (14) vorhanden ist, um direkten Kontakt zwischen der Stein-Ummantelung und der Metall-Ummantelung zu verhindern.
8. Kaminofen nach Anspruch 6 oder 7, **dadurch gekennzeichnet, dass** die Außen-Ummantelung (9) des Kaminofens außerhalb der Stein-Ummantelung (12) ein Maschenwerk, eine perforierte Platte oder durchgehendes Blech ist und in diesem Fall der Kaminofen beispielsweise ein Saunaofen ist.
9. Kaminofen nach einem der Ansprüche 1 bis 7, **dadurch gekennzeichnet, dass** die gesamte Außen-Ummantelung (9) des Kaminofens aus gut wärmespeicherndem Material, wie beispielsweise Speckstein oder Blech, besteht.
10. Kaminofen nach Anspruch 9, **dadurch gekennzeichnet, dass** der Kaminofen ein Ofen ist.
11. Kaminofen nach einem der Ansprüche 1 bis 10, **dadurch gekennzeichnet, dass** die Ansaug-Führung (6) horizontale Rippen (26), die die Abgase unter der Wärmespeicher-Masse (7) in der horizontalen Richtung führen, und in dem Bereich des Halsstücks (27) vertikale Rippen (28) enthält, die die Abgase zu dem Bereich der horizontalen Rippen (26) führen.
12. Kaminofen nach einem der Ansprüche 1 bis 11, **dadurch gekennzeichnet, dass** die Einleit-Führung (10) horizontale Rippen (29) oberhalb der Wärmespeicher-Masse (7), die die aus den Wärmespeicher-Kanälen (8) aufsteigenden Abgase sammeln und sie zu dem Abzugkanal (13) leiten, sowie vertikale Rippen (13) in dem Bereich des Abzugkanals enthält um parallele Einleit-Ströme in dem Abzugkanal zu erzeugen.
13. Kaminofen nach einem der Ansprüche 1 bis 4, **dadurch gekennzeichnet, dass** der Abgasschacht (8) Trennwände (31) enthält, die von der Ansaug-Führung (6) zu der Einleit-Führung (10) verlaufen und den ansteigenden Abgasschacht in mehrere separate Teilkanäle unterteilen.

## Revendications

1. Cheminée comportant un foyer (2) muni d'une grille (1) et d'une porte, entouré d'une enveloppe de foyer (3) et ayant une alimentation en air de combustion et une gorge (4) pour éliminer les gaz de fumée, après la gorge (4) au-dessus du foyer (2) il existe une enveloppe métallique verticale (5) qui conduit les gaz de fumée vers le haut, ayant dedans une masse d'accumulation de chaleur sensiblement continue (7) d'un matériau présentant une bonne accumulation de chaleur, disposée de sorte que les conduits de gaz de fumée (8) soient formés entre l'enveloppe métallique et la masse d'accumulation de chaleur et s'étendent sensiblement sur toute leur largeur et toute leur hauteur, et que l'enveloppe métallique (5) et l'enveloppe de foyer (3) soient entourées par l'enveloppe extérieure (9) de la cheminée, **caractérisée en ce que** dans la gorge (27) ou après la gorge en dessous de la masse d'accumulation de chaleur (7) il existe des guides d'aspiration (6) pour guider les gaz de fumée chauds uniformément autour de la masse d'accumulation de chaleur (7), et au-dessus de la masse d'accumulation de chaleur (7) il existe des guides d'injection (10) pour distribuer le tirage de la conduite d'évacuation suivante (13) uniformément autour de la masse d'accumulation de chaleur.
2. Cheminée selon la revendication 1, **caractérisée en ce que** la masse d'accumulation de chaleur (7) est formée par des dalles en stéatite superposées d'une épaisseur uniforme, s'étendant pratiquement sur toute la section transversale horizontale de l'intérieur de l'enveloppe métallique (5).
3. Cheminée selon la revendication 1 ou 2, **caractérisée en ce que** sur l'enveloppe métallique (5) il existe un couvercle d'ouverture (11) pour le nettoyage et l'entretien de la masse d'accumulation de chaleur (7).
4. Cheminée selon la revendication 2 ou 3, **caractérisée en ce que** les dalles en stéatite (7) sont des carrés, où les diagonales correspondent au diamètre de l'enveloppe métallique (5) d'une forme cylindrique, les carrés étant disposés à l'intérieur de l'enveloppe métallique de sorte que la position des coins varie de manière à former des conduits de gaz de fumée détournés.
5. Cheminée selon l'une quelconque des revendications 2 à 4, **caractérisée en ce que** les dalles en stéatite (7) sont variables et irrégulières au niveau des bords extérieurs.
6. Cheminée selon l'une quelconque des revendications 1 à 5, **caractérisée en ce qu'**à l'extérieur de l'enveloppe métallique (5) il existe une enveloppe discontinue en pierre (12) ayant une grande surface d'accumulation de chaleur.
7. Cheminée selon la revendication 6, **caractérisée en ce qu'**entre l'enveloppe métallique (5) et l'enveloppe en pierre (12) il existe un entrefer (14) pour empêcher un contact direct entre l'enveloppe en pierre et l'enveloppe métallique.
8. Cheminée selon la revendication 6 ou 7, **caractérisée en ce que** l'enveloppe extérieure (9) de la cheminée à l'extérieur de l'enveloppe en pierre (12) est un maillage, une plaque perforée ou une feuille métallique continue, dans ce cas la cheminée est par exemple un poêle de sauna.
9. Cheminée selon l'une quelconque des revendications 1 à 7, **caractérisée en ce que** l'ensemble de l'enveloppe extérieure (9) de la cheminée est réalisé en un matériau présentant une bonne accumulation de chaleur, tel que la stéatite ou une feuille métallique.
10. Cheminée selon la revendication 9, **caractérisée en ce que** la cheminée est un poêle.
11. Cheminée selon l'une quelconque des revendications 1 à 10, **caractérisée en ce que** le guide d'aspiration (6) comporte des nervures horizontales (26) pour guider les gaz de fumée sous la masse d'accumulation de chaleur (7) dans la direction horizontale, et, dans la zone de la gorge (27), des nervures verticales (28) pour guider les gaz de fumée vers la zone des nervures horizontales (26).
12. Cheminée selon l'une quelconque des revendications 1 à 11, **caractérisée en ce que** le guide d'injection (10) comporte des nervures horizontales (29) au-dessus de la masse d'accumulation de chaleur (7) pour collecter les gaz de fumée montant des canaux d'accumulation de chaleur (8) et les guider vers le canal d'évacuation (13), et des nervures verticales (30) dans la zone du canal d'évacuation pour former des flux d'injection parallèles dans le canal d'évacuation.
13. Cheminée selon l'une quelconque des revendications 1 à 4, **caractérisée en ce que** le conduit de gaz de fumée (8) comporte des parois de séparation (31) s'étendant depuis le guide d'aspiration (6) vers le guide d'injection (10) pour diviser le conduit de gaz de fumée montant en plusieurs sous-canaux séparés.

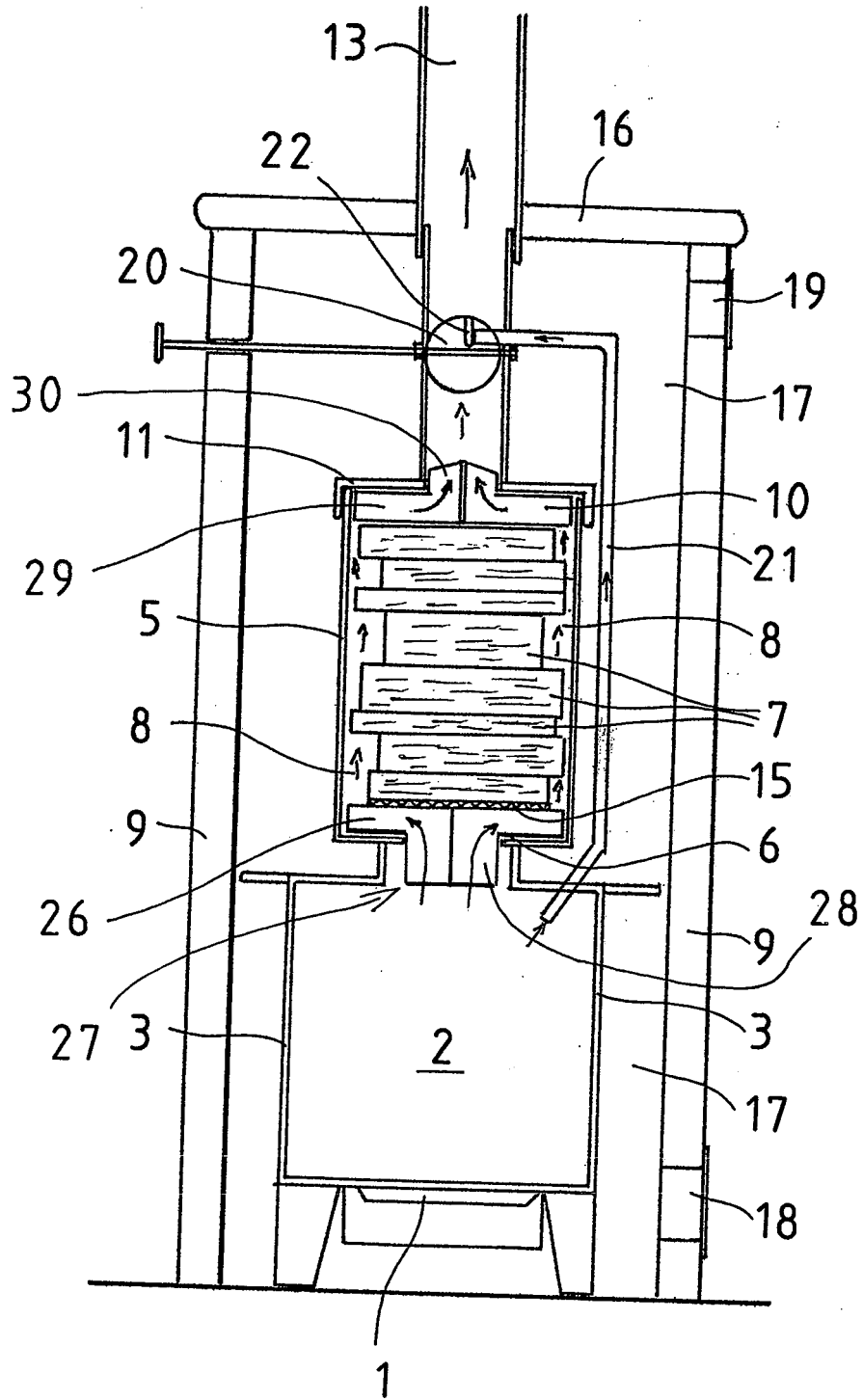

Fig 1

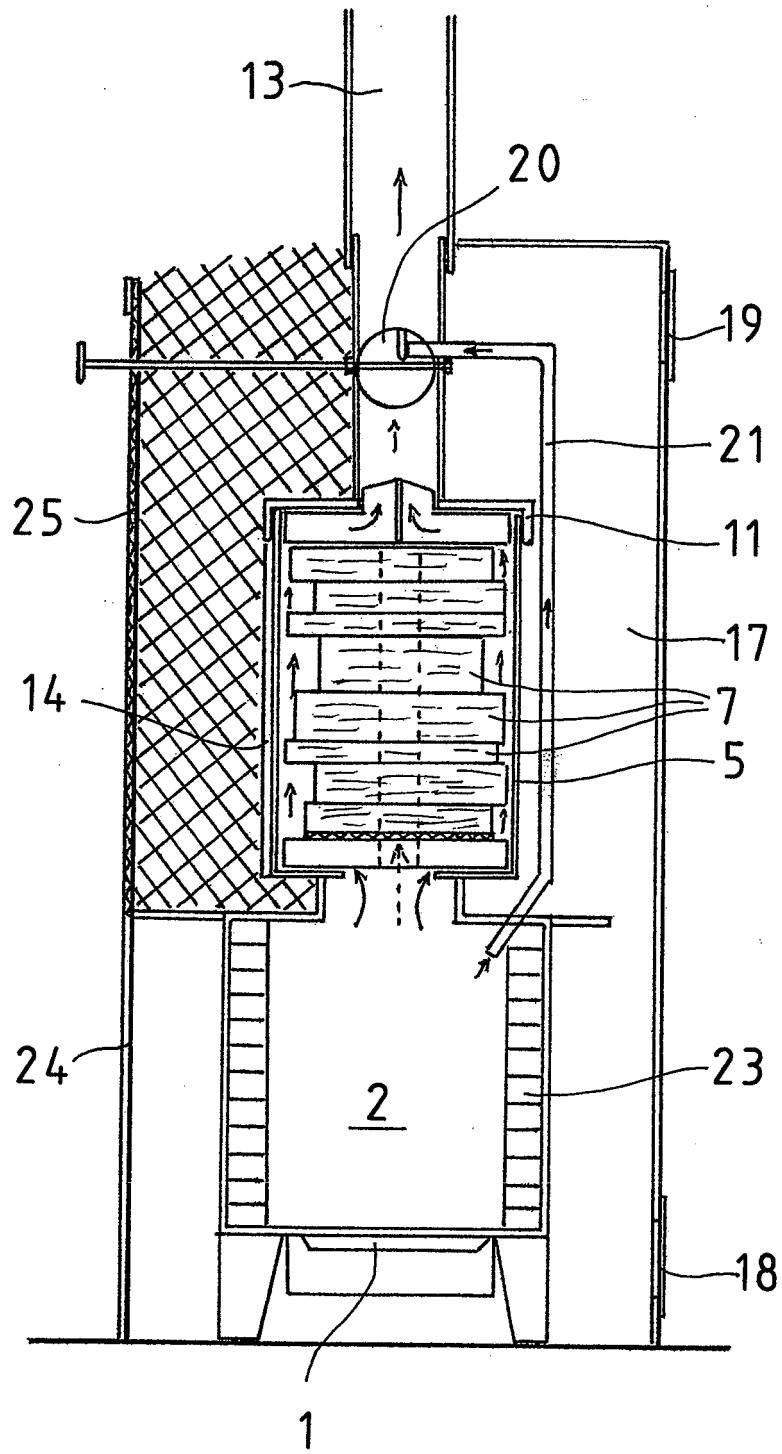

Fig 2

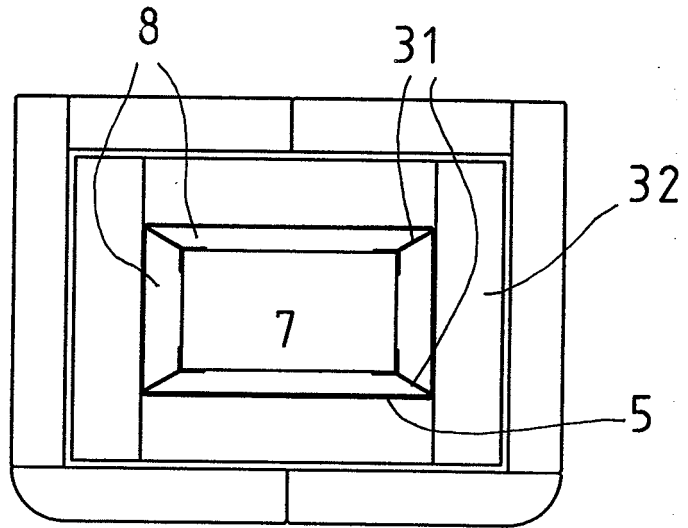

Fig 3

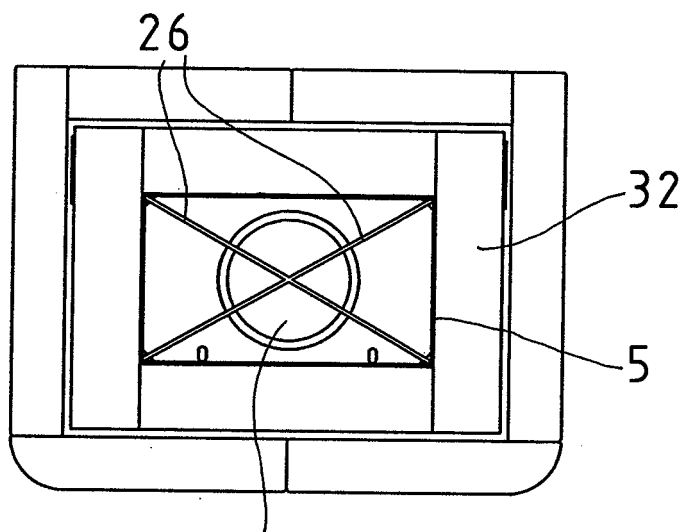

Fig 4

27

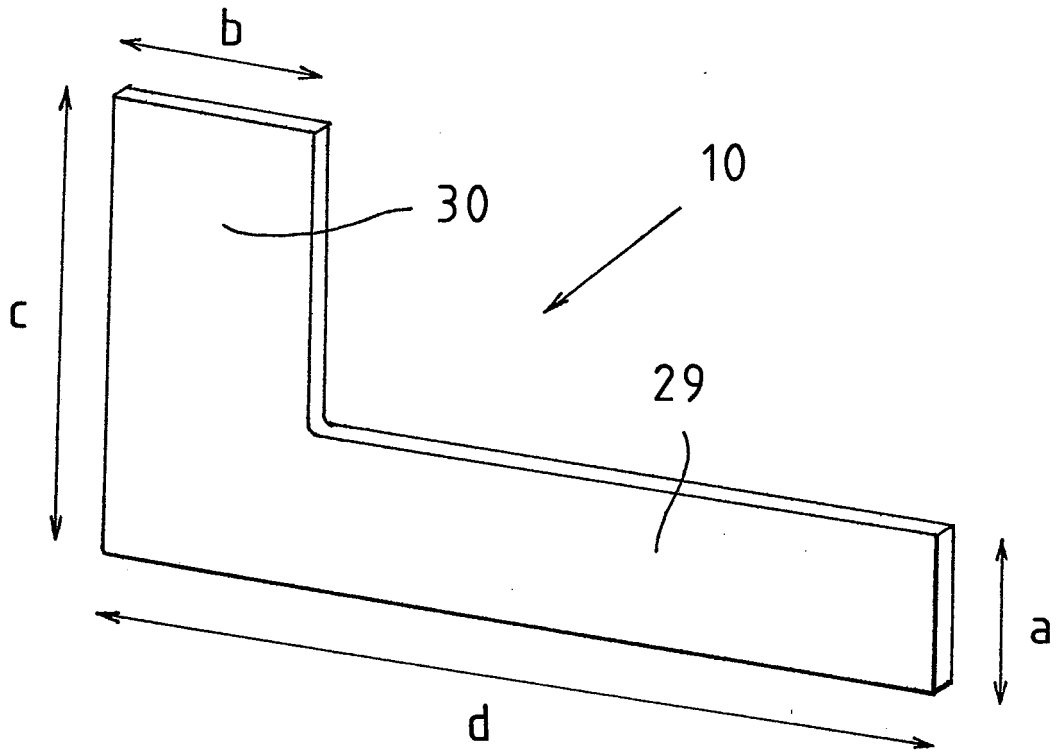

Fig 5

**REFERENCES CITED IN THE DESCRIPTION**

*This list of references cited by the applicant is for the reader's convenience only. It does not form part of the European patent document. Even though great care has been taken in compiling the references, errors or omissions cannot be excluded and the EPO disclaims all liability in this regard.*

**Patent documents cited in the description**

- EP 1376014 A2 [0004]