

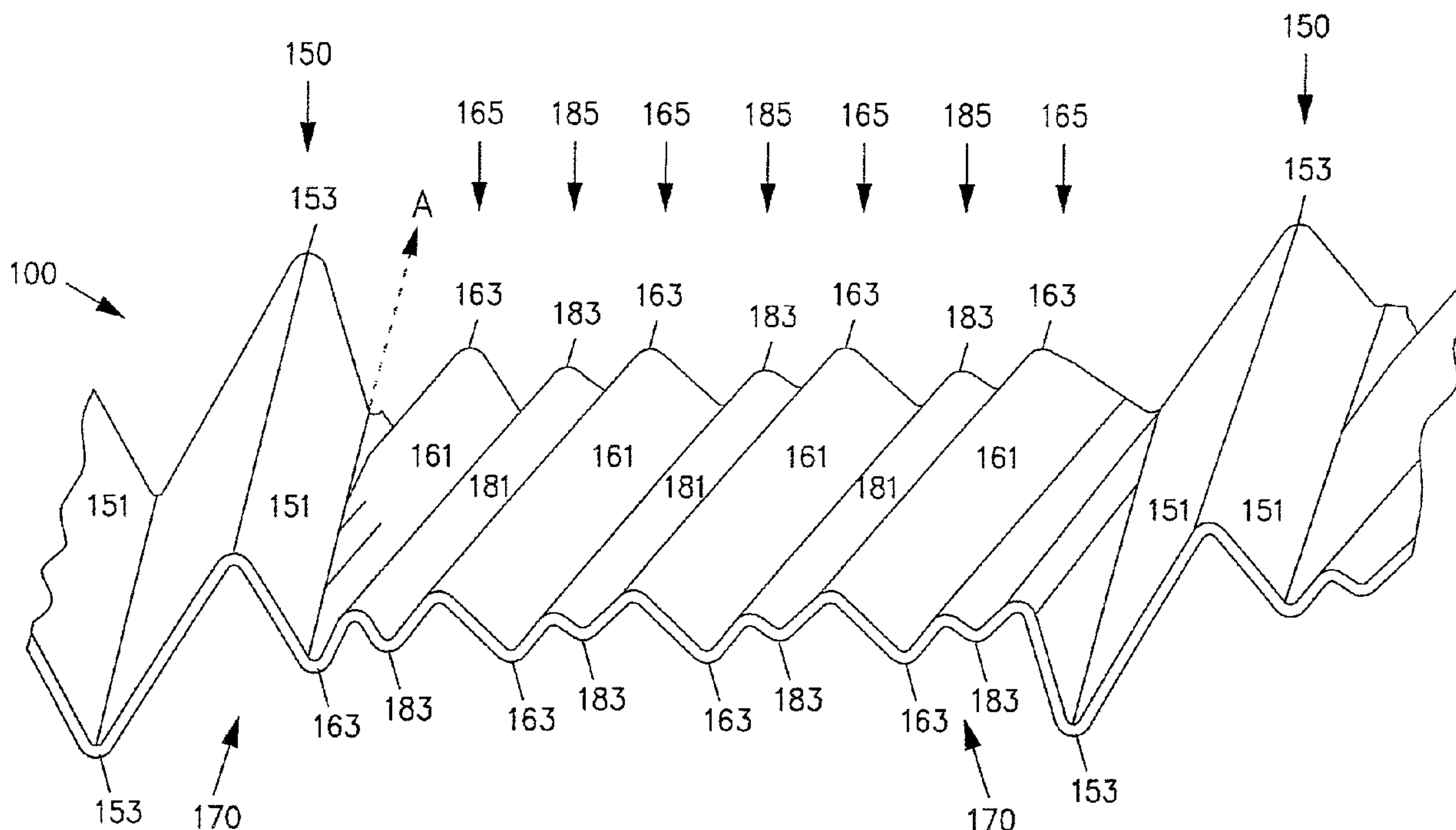

(86) **Date de dépôt PCT/PCT Filing Date:** 2010/07/09
 (87) **Date publication PCT/PCT Publication Date:** 2011/02/24
 (45) **Date de délivrance/Issue Date:** 2014/10/28
 (85) **Entrée phase nationale/National Entry:** 2012/02/14
 (86) **N° demande PCT/PCT Application No.:** US 2010/041477
 (87) **N° publication PCT/PCT Publication No.:** 2011/022131
 (30) **Priorité/Priority:** 2009/08/19 (US12/543,648)

(51) **Cl.Int./Int.Cl. F28D 19/04** (2006.01),
F28F 3/04 (2006.01)
 (72) **Inventeur/Inventor:**
SEEBALD, JAMES D., US
 (73) **Propriétaire/Owner:**
ALSTOM TECHNOLOGY LTD, CH
 (74) **Agent:** SMART & BIGGAR

(54) **Titre : ELEMENT DE TRANSMISSION DE CHALEUR POUR UN ECHANGEUR DE CHALEUR ROTATIF A RECUPERATION**
 (54) **Title: HEAT TRANSFER ELEMENT FOR A ROTARY REGENERATIVE HEAT EXCHANGER**



(57) **Abrégé/Abstract:**

A rotary regenerative heat exchanger [1] employs heat transfer elements [100] shaped to include notches [150], which provide spacing between adjacent elements [100], and undulations (corrugations) [165, 185] in the sections between the notches 150. The elements [100] described herein include undulations [165, 185] that differ in height and/or width. These impart turbulence in the air or flue gas flowing between the elements [100] to improve heat transfer.

(12) INTERNATIONAL APPLICATION PUBLISHED UNDER THE PATENT COOPERATION TREATY (PCT)

(19) World Intellectual Property Organization
International Bureau(43) International Publication Date
24 February 2011 (24.02.2011)(10) International Publication Number
WO 2011/022131 A3

- (51) International Patent Classification:
F28D 19/04 (2006.01) *F28F 3/04* (2006.01)
- (21) International Application Number:
PCT/US2010/041477
- (22) International Filing Date:
9 July 2010 (09.07.2010)
- (25) Filing Language: English
- (26) Publication Language: English
- (30) Priority Data:
12/543,648 19 August 2009 (19.08.2009) US
- (71) Applicant (for all designated States except US): **ALSTOM TECHNOLOGY LTD** [CH/CH]; Brown Boveri Strasse 7, CH-5400 Baden (CH).
- (72) Inventor; and
- (75) Inventor/Applicant (for US only): **SEEBALD, James D.** [US/US]; 1904 Riverview Drive, Wellsville, New York 14895 (US).
- (74) Agents: **ZALE, Lawrence P.** et al.; ALSTOM Power Inc., 200 Great Pond Drive, P.O. Box 500, Windsor, Connecticut 06095-0500 (US).
- (81) Designated States (unless otherwise indicated, for every kind of national protection available): AE, AG, AL, AM, AO, AT, AU, AZ, BA, BB, BG, BH, BR, BW, BY, BZ,

CA, CH, CL, CN, CO, CR, CU, CZ, DE, DK, DM, DO, DZ, EC, EE, EG, ES, FI, GB, GD, GE, GH, GM, GT, HN, HR, HU, ID, IL, IN, IS, JP, KE, KG, KM, KN, KP, KR, KZ, LA, LC, LK, LR, LS, LT, LU, LY, MA, MD, ME, MG, MK, MN, MW, MX, MY, MZ, NA, NG, NI, NO, NZ, OM, PE, PG, PH, PL, PT, RO, RS, RU, SC, SD, SE, SG, SK, SL, SM, ST, SV, SY, TH, TJ, TM, TN, TR, TT, TZ, UA, UG, US, UZ, VC, VN, ZA, ZM, ZW.

(84) Designated States (unless otherwise indicated, for every kind of regional protection available): ARIPO (BW, GH, GM, KE, LR, LS, MW, MZ, NA, SD, SL, SZ, TZ, UG, ZM, ZW), Eurasian (AM, AZ, BY, KG, KZ, MD, RU, TJ, TM), European (AL, AT, BE, BG, CH, CY, CZ, DE, DK, EE, ES, FI, FR, GB, GR, HR, HU, IE, IS, IT, LT, LU, LV, MC, MK, MT, NL, NO, PL, PT, RO, SE, SI, SK, SM, TR), OAPI (BF, BJ, CF, CG, CI, CM, GA, GN, GQ, GW, ML, MR, NE, SN, TD, TG).

Published:

- with international search report (Art. 21(3))
- before the expiration of the time limit for amending the claims and to be republished in the event of receipt of amendments (Rule 48.2(h))

(88) Date of publication of the international search report:
14 April 2011

(54) Title: HEAT TRANSFER ELEMENT FOR A ROTARY REGENERATIVE HEAT EXCHANGER

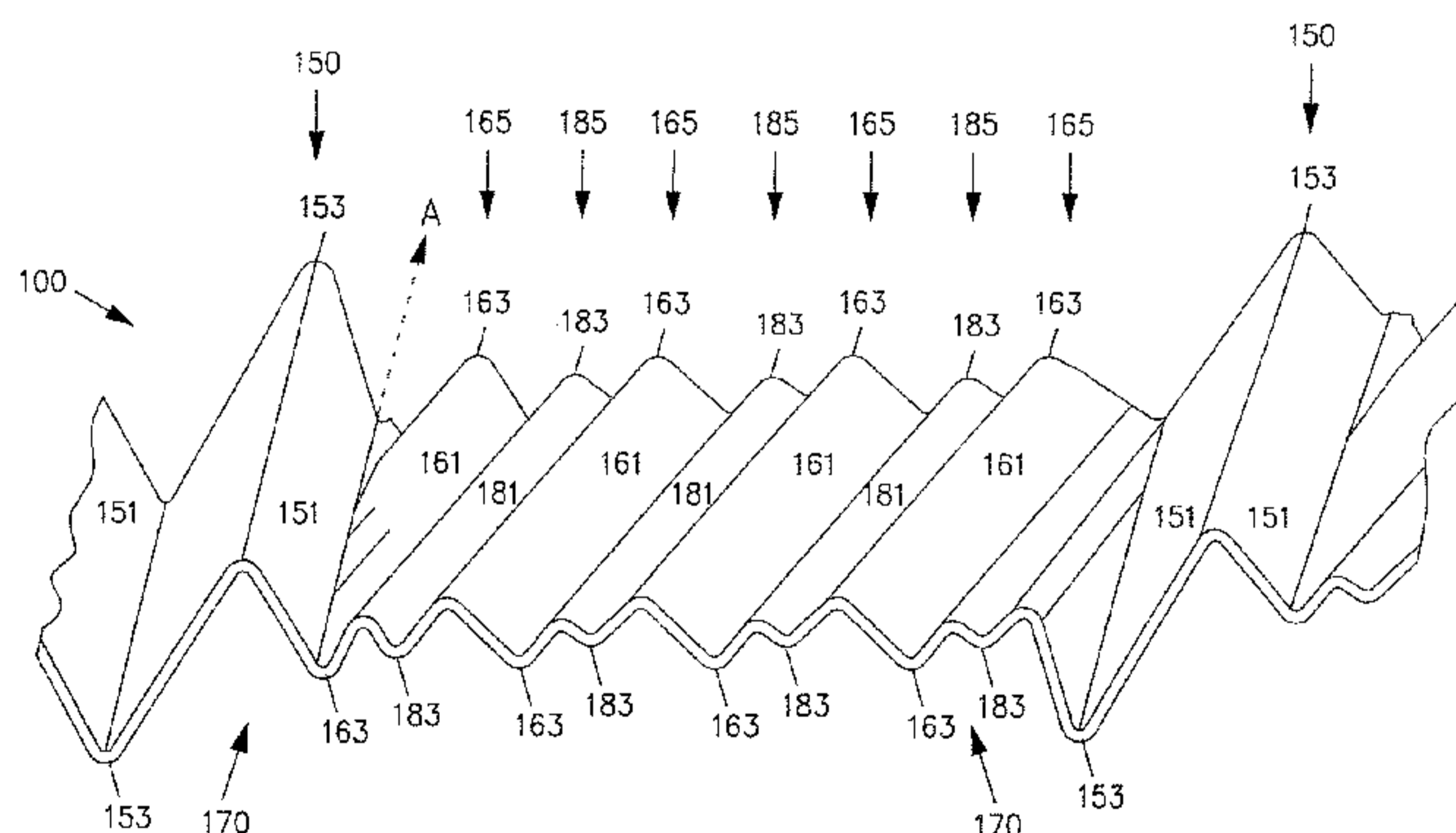

Figure 6

(57) Abstract: A rotary regenerative heat exchanger [1] employs heat transfer elements [100] shaped to include notches [150], which provide spacing between adjacent elements [100], and undulations (corrugations) [165,185] in the sections between the notches 150. The elements [100] described herein include undulations [165,185] that differ in height and/or width. These impart turbulence in the air or flue gas flowing between the elements [100] to improve heat transfer.

HEAT TRANSFER ELEMENT FOR A ROTARY REGENERATIVE HEAT EXCHANGER

BACKGROUND

[0001] The present invention relates to heat transfer elements of the type found in rotary regenerative heat exchangers.

[0002] Rotary regenerative heat exchangers are commonly used to transfer heat from flue gases exiting a furnace to the incoming combustion air. Conventional rotary regenerative heat exchangers, such as that shown as 1 in Fig. 1, have a rotor 12 mounted in a housing 14. The housing 14 defines a flue gas inlet duct 20 and a flue gas outlet duct 22 for the flow of heated flue gases 36 through the heat exchanger 1. The housing 14 further defines an air inlet duct 24 and an air outlet duct 26 for the flow of combustion air 38 through the heat exchanger 1. The rotor 12 has radial partitions 16 or diaphragms defining compartments 17 therebetween for supporting baskets (frames) 40 of heat transfer elements. The rotary regenerative heat exchanger 1 is divided into an air sector and a flue gas sector by sector plates 28, which extend across the housing 14 adjacent the upper and lower faces of the rotor 12.

[0003] Fig. 2 depicts an end elevation view of an example of an element basket 40 including a few elements 10 stacked therein. While only a few elements 10 are shown, it will be appreciated that the basket 40 will typically be filled with elements 10. As can be seen in Fig. 2, the elements 10 are closely stacked in spaced relationship within the element basket 40 to form passageways 70 between the elements 10 for the flow of air or flue gas.

[0004] Referring to Figs. 1 and 2, the hot flue gas stream 36 is directed through the gas sector of the heat exchanger 1 and transfers heat to the elements 10 on the continuously rotating rotor 12. The elements 10 are then rotated about axis 18 to the air sector of the heat exchanger 1, where the combustion air stream 38 is directed over the elements 10 and is thereby heated. In other forms of rotary regenerative heat exchangers, the elements 10 are stationary and the air and gas inlet and outlet portions of the housing 14 rotate.

[0005] Fig. 3 depicts portions of conventional elements 10 in stacked relationship, and Fig. 4 depicts a cross-section of one of the conventional elements 10. Typically, elements 10 are steel sheets that have been shaped to include one or more various notches 50 and undulations 65.

[0006] Notches 50, which extend outwardly from the element 10 at generally equally spaced intervals, maintain spacing between adjacent elements 10 when the elements 10 are stacked as shown in Fig. 3, and thus form sides of the passageways 70 for the air or flue gas between the elements 10. Typically, the notches 50 extend at a predetermined angle (e.g. 90 degrees) relative to the fluid flow through the rotor (12 of Fig. 1).

[0007] In addition to the notches 50, the element 10 is typically corrugated to provide a series of undulations (corrugations) 65 extending between adjacent notches 50 at an acute angle A_u to the flow of heat exchange fluid, indicated by the arrow marked "A" in Fig. 3. The undulations 65 have a height of H_u and act to increase turbulence in the air or flue gas flowing through the passageways 70 and thereby disrupt the thermal boundary layer that would otherwise exist in that part of the fluid medium (either air or flue gas) adjacent to the surface of the element 10. The existence of an undisrupted fluid boundary layer tends to impede heat transfer between the fluid and the element 10. The undulations 65 on adjacent elements 10 extend obliquely to the line of flow. In this manner, the undulations 65 improve heat transfer between the element 10 and the fluid medium. Furthermore, the elements 10 may include flat portions (not shown), which are parallel to and in full contact with the notches 50 of adjacent elements 10. For examples of other heat transfer elements 10, reference is made to U.S. Pat. Nos. 2,596,642; 2,940,736; 4,396,058; 4,744,410; 4,553,458; and 5,836,379.

[0008] Although such elements exhibit favorable heat transfer rates, the results can vary rather widely depending upon the specific design and the dimensional relationship between the notches and the undulations. For example, while the undulations provide an enhanced degree of heat transfer, they also increase the pressure drop across the heat exchanger (1 of Fig 1). Ideally, the undulations on the elements will induce a relatively high degree of turbulent flow in that part of the fluid medium adjacent to the elements, while the notches will be sized so that the fluid medium that is not adjacent to the elements (i.e., the fluid near the center of the passageways) will experience a lesser degree of turbulence, and therefore

78396-176

much less resistance to flow. However, attaining the optimum level of turbulence from the undulations can be difficult to achieve since both the heat transfer and the pressure loss tend to be proportional to the degree of turbulence that is produced by the undulations. An undulation design that raises the heat transfer tends to also raise the pressure loss and, conversely, a shape that lowers the pressure loss tends to lower the heat transfer as well.

[0009] Design of the elements must also present a surface configuration that is readily cleanable. To clean the elements, it has been customary to provide soot blowers that deliver a blast of high-pressure air or steam through the passages between the stacked elements to dislodge any particulate deposits from the surface thereof and carry them away leaving a relatively clean surface. To accommodate soot blowing, it is advantageous for the elements to be shaped such that when stacked in a basket the passageways are sufficiently open to provide a line of sight between the elements, which allows the soot blower jet to penetrate between the sheets for cleaning. Some elements do not provide for such an open channel, and although they have good heat transfer and pressure drop characteristics, they are not very well cleaned by conventional soot blowers. Such open channels also allow for the operation of a sensor for measuring the quantity of infrared radiation leaving the element. Infrared radiation sensors can be used to detect the presence of a "hot spot", which is generally recognized as a precursor to a fire in the basket (40 of Fig 2). Such sensors, commonly known as "hot spot" detectors, are useful in preventing the onset and growth of fires. Elements that do not have an open channel prevent infrared radiation from leaving the element and from being detected by the hot spot detector.

[0010] Thus, there is a need for a rotary regenerative heat exchanger heat transfer element that provides decreased pressure loss for a given amount of heat transfer and that is readily cleanable by a soot blower and compatible with a hot spot detector.

78396-176

SUMMARY OF THE INVENTION

[0011] The present invention may be embodied as a heat transfer element for a rotary regenerative heat exchanger including:

5 [0012] notches extending parallel to each other and configured to form passageways between adjacent heat transfer elements, each of the notches including lobes projecting outwardly from opposite sides of the heat transfer element and having a peak-to-peak height H_n ;

[0013] first undulations extending parallel to each other between the notches, each of the first undulations including lobes projecting outwardly from the opposite sides of the heat transfer element having a peak-to-peak height H_{u1} ; and

10 [0014] second undulations extending parallel to each other between the notches, each of the second undulations including lobes projecting outwardly from the opposite sides of the heat transfer element having a peak-to-peak height H_{u2} , wherein H_{u2} is less than H_{u1} .

[0015] It may also be embodied as a heat transfer element for a rotary regenerative heat exchanger including:

15 [0016] notches extending parallel to each other and configured to form passageways between adjacent heat transfer elements, each of the notches including lobes projecting outwardly from opposite sides of the heat transfer element and having a peak-to-peak height H_n ;

[0017] first undulations disposed between the notches, the first undulations extending parallel to each other and having a width W_{u1} ;

20 [0018] second undulations disposed between the notches, the second undulations extending parallel to each other and having a width W_{u2} , wherein W_{u1} is not equal to W_{u2} .

[0019] The present invention may also be embodied as a basket for a rotary regenerative heat exchanger including:

25 [0020] a plurality of heat transfer elements stacked in spaced relationship thereby providing a plurality of passageways between adjacent heat transfer elements for flowing a heat exchange fluid therebetween, each of the heat transfer elements including:

78396-176

[0021] notches extending parallel to each other and configured to form passageways between adjacent heat transfer elements, each of the notches including lobes projecting outwardly from opposite sides of the heat transfer element and having a peak-to-peak height H_n ;

5 [0022] first undulations extending parallel to each other between the notches, each of the first undulations including lobes projecting outwardly from the opposite sides of the heat transfer element having a peak-to-peak height H_{u1} ; and

[0023] second undulations extending parallel to each other between the notches, each of the second undulations including lobes projecting outwardly from the opposite sides of the heat transfer element having a peak-to-peak height H_{u2} , wherein H_{u2} is less than H_{u1} , and H_{u1} is less
10 than H_n .

BRIEF DESCRIPTION OF THE DRAWINGS

[0024] The subject matter regarded as the invention is particularly pointed out and distinctly claimed in the claims at the conclusion of the specification. The foregoing and other features and advantages of some embodiments of the invention are apparent from the following detailed
15 description taken in conjunction with the accompanying drawings in which:

[0025] Fig. 1 is a partially broken away perspective view of a prior art rotary regenerative heat exchanger;

[0026] Fig. 2 is a top plan view of a prior art element basket including a few heat transfer elements;

20 [0027] Fig. 3 is a perspective view of a portion of three prior art heat transfer elements in stacked configuration;

[0028] Fig. 4 is a cross-sectional elevation view of a prior art heat transfer element;

[0029] Fig. 5 is a cross-sectional elevation view of a heat transfer element in accordance with an embodiment of the present invention; and

25 [0030] Fig. 6 is a perspective view of a portion of a heat transfer element in accordance with the embodiment of the present invention.

DESCRIPTION OF THE PREFERRED EMBODIMENT

[0031] Figs. 5 and 6 depict a portion of a heat transfer element 100 in accordance with an embodiment of the present invention. The element 100 may be used in place of conventional elements 10 in a rotary regenerative heat exchanger (1 of Fig. 1). For example, elements 100 may be stacked as shown in Fig. 3 and inserted in a basket 40 as depicted in Fig. 2 for use in the rotary regenerative heat exchanger 1 of the type depicted in Fig. 1.

[0032] The invention will be described in connection with reference to both Figs. 5 and 6. The element 100 is formed from thin sheet metal capable of being rolled or stamped to the desired configuration. Element 100 has a series of notches 150 at spaced intervals which extend longitudinally and approximately parallel to the direction of flow of the heat exchange fluid past element 100 as indicated by the arrow labeled "A". These notches 150 maintain adjacent elements 100 a predetermined distance apart and form the flow passages 170 between the adjacent elements 100 when the elements 100 are stacked. Each notch 150 comprises one lobe 151 projecting outwardly from the surface of the element 100 on one side and another lobe 151 projecting outwardly from the surface of the element 100 on the opposite side. Each lobe 151 may be in the form of a U-shaped groove with the peaks 153 of the notches 150 directed outwardly from the element 100 in opposite directions. The peaks 153 of the notches 150 contact the adjacent elements 100 to maintain the element 100 spacing. As also noted, the elements 100 may be arranged such that the notches 150 on one element 100 are located about mid-way between the notches 150 on the adjacent elements 100 for maximum support. Although not shown, it is contemplated that the element 100 may include a flat region that extends parallel to the notches 150, upon which the notch 150 of an adjacent element 100 rests. The peak-to-peak height between the lobes 151 for each notch 150, is designated H_n .

[0033] Disposed on the element 100 between the notches 150 are undulation (corrugation) 165, 185 having two different heights. Each of these comprises a plurality of undulations 165, 185, respectively. While only a portion of the element 100 is shown, it will be appreciated that an element 100 may include several notches 150 with undulations 165 and 185 disposed between each pair of notches 150.

[0034] Each undulation 165 extends parallel to the other undulations 165 between the notches 150. Each undulation 165 includes one lobe 161 projecting outwardly from the surface of the element 100 on one side and another lobe 161 projecting outwardly from the surface of the element 100 on the opposite side. Each lobe 161 may be in the form of a U-shaped channel with the peaks 163 of the channels directed outwardly from the element 100 in opposite directions. Each of the undulations 165 has a peak-to-peak height $Hu1$ between the peaks 163.

[0035] Each undulation 185 extends parallel to the other undulations 185 between the notches 150. Each undulation 185 includes one lobe 181 projecting outwardly from the surface of the element 100 on one side and another lobe 181 projecting outwardly from the surface of the element 100 on the opposite side. Each lobe 181 may be in the form of a U-shaped channel having peaks 183 of the channels directed outwardly from the element 100 in opposite directions. Each of the undulations 185 has a peak-to-peak height $Hu2$ between the peaks 183.

[0036] In one aspect of the present invention, $Hu1$ and $Hu2$ are of different heights. The ratio of $Hu1/Hn$ is a critical parameter because it defines the height of the open area between adjacent elements 100 forming passageways 170 for the fluid to flow through.

[0037] In the embodiment shown, $Hu2$ is less than $Hu1$, and both $Hu1$ and $Hu2$ are less than Hn . Preferably, the ratio of $Hu2/Hu1$ is greater than about 0.20 and less than about 0.80; and more preferably the ratio of $Hu2/Hu1$ is greater than about 0.35 and less than about 0.65. The ratio of $Hu2/Hn$ is preferably greater than about 0.06 and less than about 0.72, and the ratio of $Hu1/Hn$ is preferably greater than about 0.30 and less than about 0.90. When the $Hu2/Hu1$ ratio drops below 0.20, the smaller undulations have less effect on creating turbulence, and are less effective.

[0038] When the $Hu2/Hu1$ ratio is above 0.80, the two undulation heights are nearly equal and there is minimal improvement over prior art.

[0039] Once the $Hu1/Hn$ ratio and the $Hu2/Hu1$ ratios have been chosen, the $Hu2/Hn$ ratio is fixed.

[0040] In another aspect of the present invention, the individual width of each of the undulations 165 may be different than the individual width of each of the undulations 185, as indicated by Wu_1 and Wu_2 . Preferably, the ratio Wu_2/Wu_1 is greater than 0.20 and less than 1.20; and more preferably, Wu_2/Wu_1 is greater than 0.50 and less than 1.10. The selection of the Wu_1 and Wu_2 are, to a great degree, dependent on the values used for Hu_1 and Hu_2 . One of the overall objectives of the preferred embodiment of the present invention is to create an optimal amount of turbulence near the surface of the elements. This means that the shapes, as viewed in cross-section, of both types of undulations need to be designed in accordance with that goal, and the shape of each undulation is determined largely by the ratio of its height to its width. In addition, the choice of the undulation widths can also affect the quantity of surface area provided by the elements, and surface area also has an impact on the amount of heat transfer between the fluid and the elements.

[0041] In contrast, as shown in Fig. 4, the undulations 65 in conventional elements 10 are all of the same height, Hu , and are all of the same width, Wu . Wind tunnel tests have surprisingly shown that replacing the conventional, uniform undulations 65 with the undulations 165 and 185 of the present invention can reduce the pressure loss significantly (about 14%) while maintaining the same rate of heat transfer and fluid flow. This translates to a cost savings to the operator because reducing the pressure loss of the air and the flue gas as they flow through the rotary regenerative heat exchanger will reduce the electrical power consumed by the fans that are used to force the air and the flue gas to flow through the heat exchanger.

[0042] While not wanting to be bound by theory, it is believed that the difference in height and/or width between undulations 165 and 185 encountered by the heat transfer medium as it flows between the elements 100 creates more turbulence in the fluid boundary layer adjacent to the surface of the elements 100, and less turbulence in the open section of the passageways 170 that are farther away from the surface of the elements 100. The added turbulence in the boundary layer increases the rate of heat transfer between the fluid and the elements 100. The reduced turbulence away from the surface of the elements 100, serves to reduce the pressure loss as the fluid flows through the passageways 170. By adjusting the two undulation heights, Hu_1 and Hu_2 , it is possible to reduce the fluid pressure loss for the same amount of total heat transferred.

[0043] The superior heat transfer and pressure drop performance of the element 100 of the present invention also has the advantage that the angle between the undulations 165 and the primary flow direction of the heat transfer fluid can be reduced somewhat, while still maintaining an equal amount of heat transfer when compared to elements 10 having conventional, uniform undulations 65. This is also true of the angle between the undulations 185 and the primary flow direction of the heat transfer fluid.

[0044] This allows for better cleaning by a soot blower jet since the undulations 165 and 185 are better aligned with the jet. Furthermore, because a decreased undulation angle provides a better line-of sight between the elements 100, the present invention is compatible with an infrared radiation (hot spot) detector.

[0045] While the invention has been described with reference to exemplary embodiments, it will be understood by those skilled in the art that various changes may be made and equivalents may be substituted for elements thereof without departing from the scope of the invention. In addition, many modifications will be appreciated by those skilled in the art to adapt a particular instrument, situation or material to the teachings of the invention without departing from the essential scope thereof. Therefore, it is intended that the invention not be limited to the particular embodiment disclosed as the best mode contemplated for carrying out this invention, but that the invention will include all embodiments falling within the scope of the appended claims.

78396-176

CLAIMS:

1. A heat transfer element for a rotary regenerative heat exchanger exhibiting high efficiency and low maintenance comprising:

notches extending parallel to each other and configured to form passageways
 5 between adjacent heat transfer elements, each of the notches including lobes projecting outwardly from opposite sides of the heat transfer element and having a peak-to-peak height H_n ;

first undulations extending parallel to each other between the notches, each of the first undulations including lobes projecting outwardly from the opposite sides of the heat
 10 transfer element having a peak-to-peak height H_{u1} ; and

second undulations extending parallel to each other between the notches, each of the second undulations including lobes projecting outwardly from the opposite sides of the heat transfer element having a peak-to-peak height H_{u2} , wherein H_{u2} is less than H_{u1} .

2. The heat transfer element of claim 1, wherein H_{u1} is less than H_n .

15 3. The heat transfer element of claim 1, wherein the ratio of H_{u2}/H_{u1} is greater than 0.2 and less than 0.8.

4. The heat transfer element of claim 3, wherein the ratio of H_{u2}/H_n is greater than about 0.06 and less than about 0.72.

5. The heat transfer element of claim 4 wherein the ratio of H_{u1}/H_n is greater than
 20 about 0.30 and less than about 0.9.

6. The heat transfer element of claim 1, wherein the first undulations have a width of W_{u1} , the second undulations have a width of W_{u2} , and W_{u1} is not equal to W_{u2} .

7. The heat transfer element of claim 6 wherein W_{u2}/W_{u1} is greater than about 0.2 and less than about 1.2.

78396-176

8. The heat transfer element of claim 1, wherein the heat transfer element further comprises a flat region disposed between the notches and extending parallel thereto.

9. A heat transfer element for a rotary regenerative heat exchanger exhibiting high efficiency and low maintenance comprising:

5 notches extending parallel to each other and configured to form passageways between adjacent heat transfer elements, each of the notches including lobes projecting outwardly from opposite sides of the heat transfer element and having a peak-to-peak height H_n ;

10 first undulations disposed between the notches, the first undulations extending parallel to each other and having a width W_{u1} ;

second undulations disposed between the notches, the second undulations extending parallel to each other and having a width W_{u2} , wherein W_{u1} is not equal to W_{u2} .

10. The heat transfer element of claim 9, wherein the first undulations have a height of H_{u1} , the second undulations have a height of H_{u2} , and H_{u1} is not equal to H_{u2} .

15 11. The heat transfer element of claim 10, wherein H_{u1} is less than H_n .

12. The heat transfer element of claim 10, wherein the ratio of H_{u2}/H_{u1} is greater than 0.2 and less than 0.8.

13. The heat transfer element of claim 10, wherein the ratio of H_{u2}/H_n is greater than about 0.06 and less than about 0.72.

20 14. The heat transfer element of claim 10 wherein the ratio of H_{u1}/H_n is greater than about 0.30 and less than about 0.9.

15. A basket for a rotary regenerative heat exchanger exhibiting high efficiency and low maintenance comprising:

78396-176

a plurality of heat transfer elements stacked in spaced relationship thereby providing a plurality of passageways between adjacent heat transfer elements for flowing a heat exchange fluid therebetween, each of the heat transfer elements including:

notches extending parallel to each other and configured to form passageways
 5 between adjacent heat transfer elements, each of the notches including lobes projecting outwardly from opposite sides of the heat transfer element and having a peak-to-peak height H_n ;

first undulations extending parallel to each other between the notches, each of the first undulations including lobes projecting outwardly from the opposite sides of the heat
 10 transfer element having a peak-to-peak height H_{u1} ; and

second undulations extending parallel to each other between the notches, each of the second undulations including lobes projecting outwardly from the opposite sides of the heat transfer element having a peak-to-peak height H_{u2} , wherein H_{u2} is less than H_{u1} , and H_{u2} is less than H_n .

15 16. The basket of claim 15, wherein the ratio of H_{u2}/H_{u1} is greater than about 0.20 and less than about 0.80.

17. The basket of claim 16, wherein the ratio of H_{u1}/H_n is greater than about 0.3 and less than about 0.9.

18. The basket of claim 15, wherein the first undulations have a width of W_{u1} , the
 20 second undulations have a width of W_{u2} , and W_{u1} is not equal to W_{u2} .

19. The basket of claim 18 wherein W_{u2}/W_{u1} is greater than about 0.2 and less than about 1.2.

20. The basket of claim 15, wherein the heat transfer element further comprises a flat region disposed between the notches and extending parallel thereto.

1/4

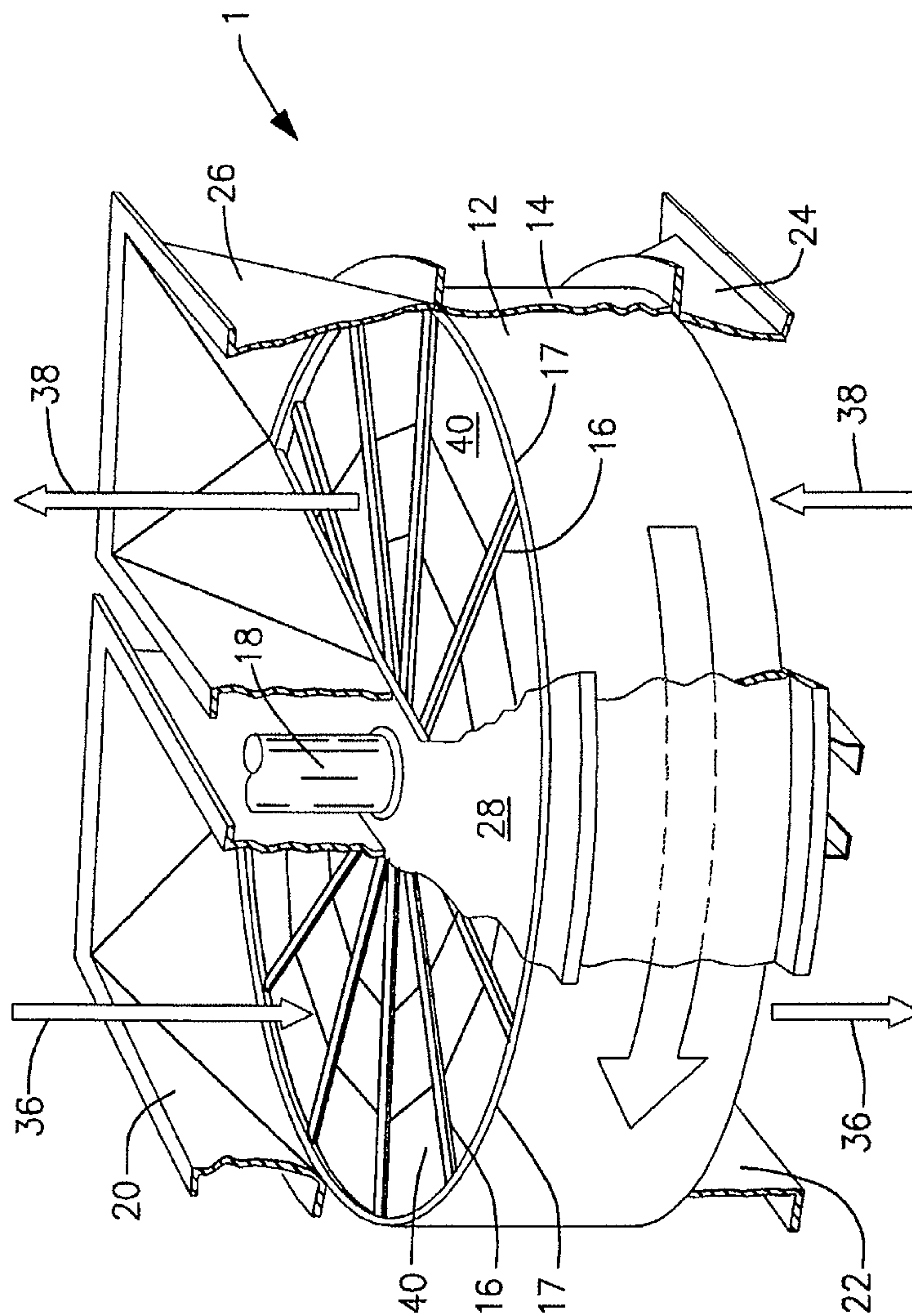

Figure 1
PRIOR ART

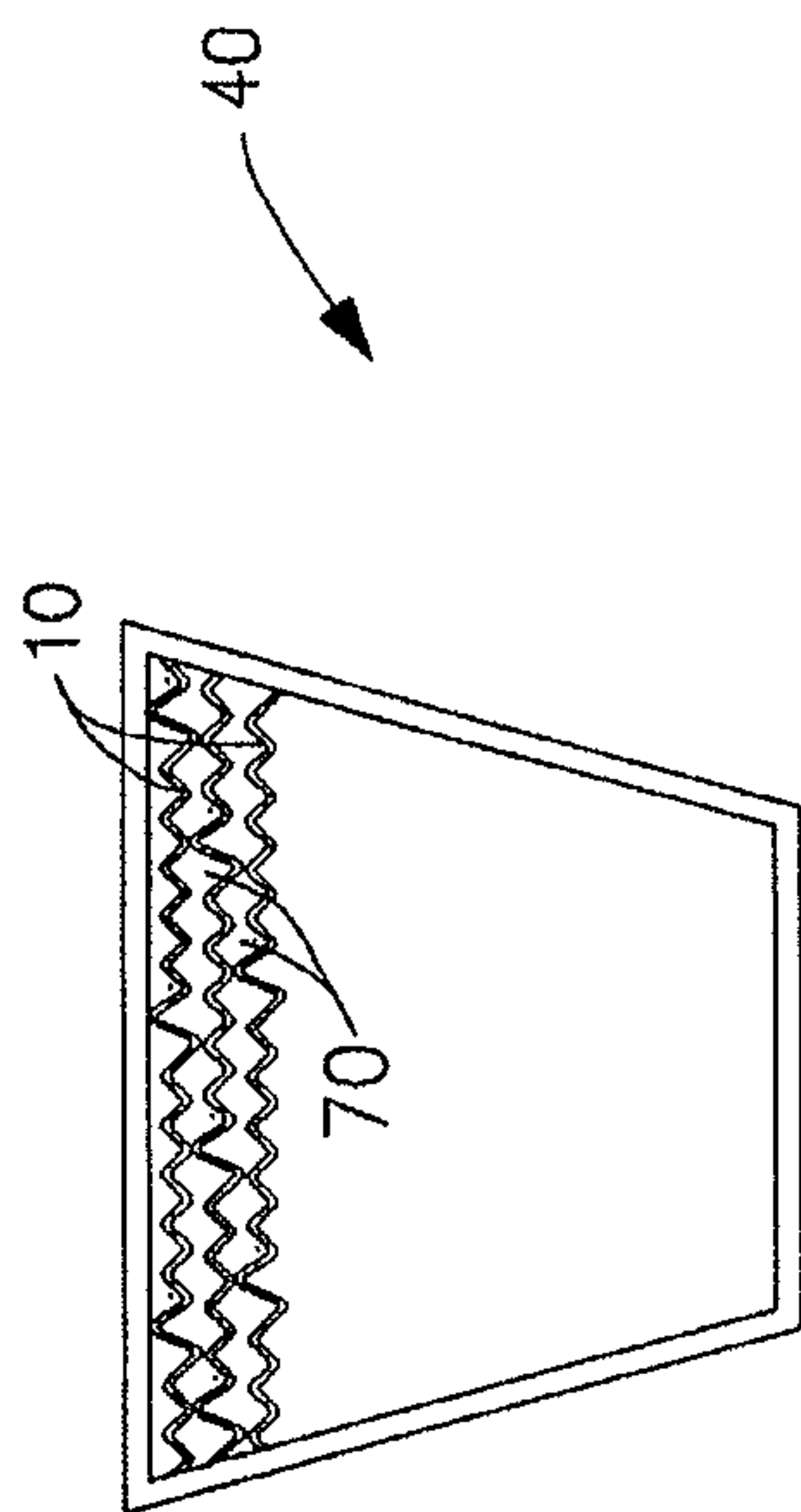

Figure 2
PRIOR ART

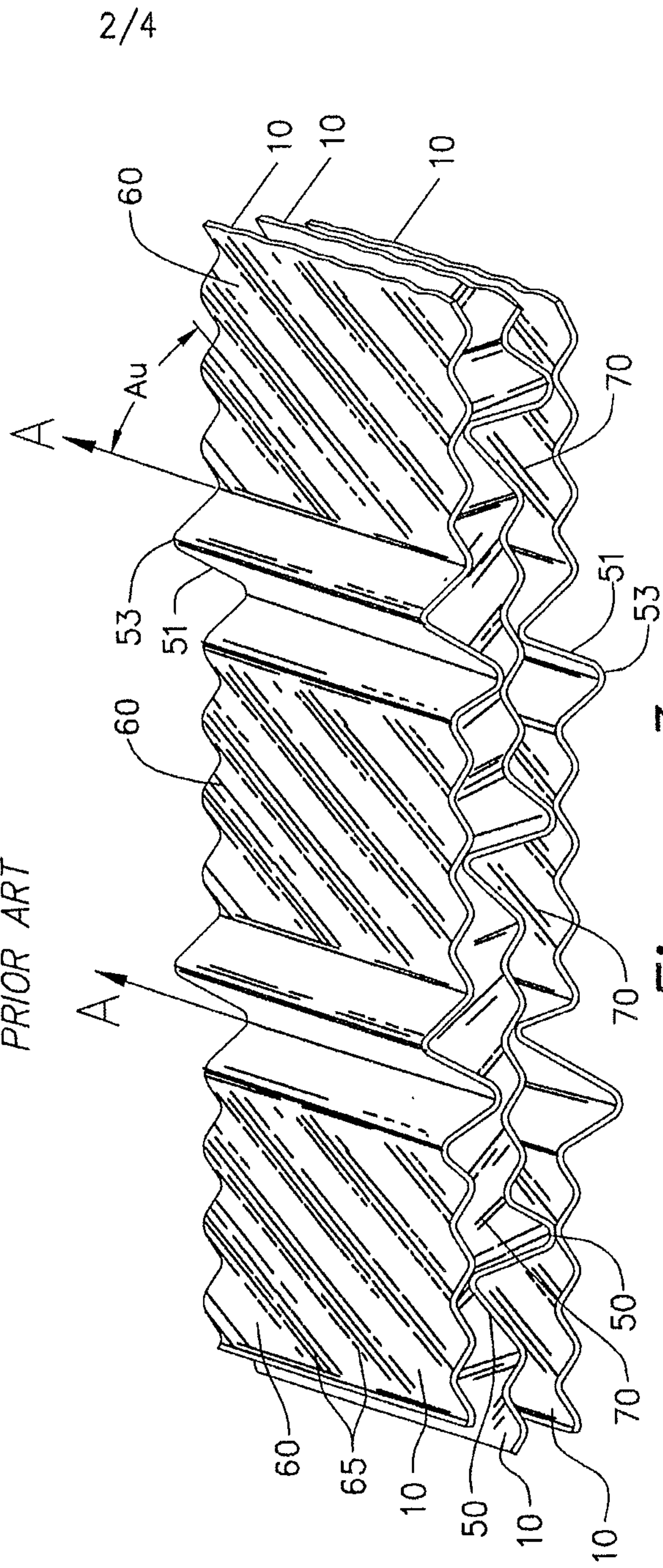

Figure 3
PRIOR ART

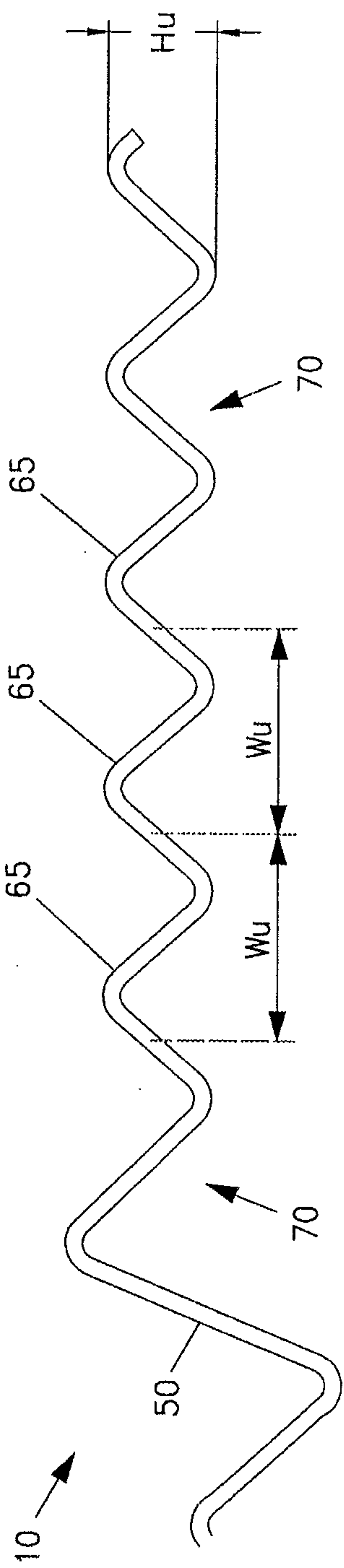

Figure 4
PRIOR ART

3/4

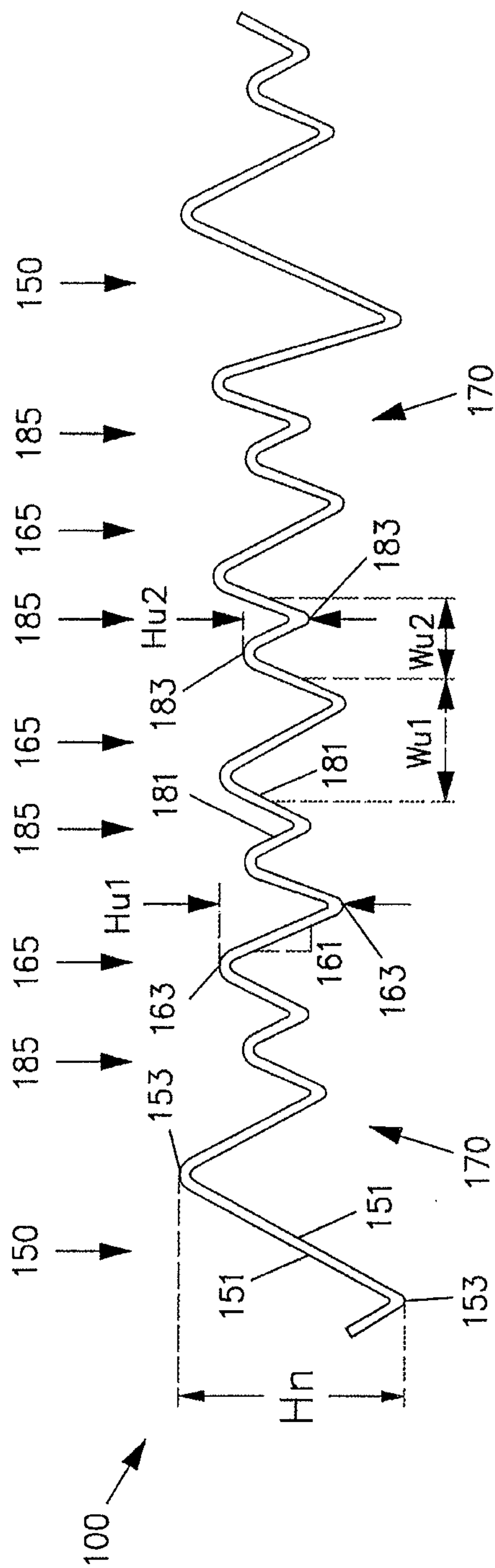

Figure 5

