

(19)  
(12)

(KR)  
(A)

(51) 。 Int. Cl.7  
E21D 20/00

(11)  
(43)

2003-0056025  
2003 07 04

(21) 10-2001-0086177  
(22) 2001 12 27

(71) 649 306 1204

(72) 649 306 1204

(74)  
:

(54)

가 가 , .  
, (14) (12)가 (10) , (10)  
(16) (18) , (10) (24) , (10)  
(23) (1) , (24) (10)  
) 가 (1)가 , (10) (24) (24) (10)

3

1 2

3 4

5 7

< >

1. 10.

12. 14.

18. 23.

24.

, 가 가 ,

, .

, ,

, , , ,

, .

1 2

(10) (20) (12)가 (20) (14) (10) (18) (

12) (20) (21) , (22) , (10) (

(1) 가 (2)

(4) (8) (10) (12) (20) (22) (1) (

(1) (10) (10) (2) . ,

, (1) (10)가 (20)가 , (20) 가

, (20) 가 ,

가 , 가

가 ,

(14) (12)가 (10) (10)

(16) (18) , (10) (24) , (10) (10)

(23) , (1) (24) (24) (10)

가 (1)가 . (10) (24)

, (24) , (24) , (10) 가

2)가 (10) (16) (18) (1) (10) (14) (16) (18)가 (1)

(10) (10) (24) (24)가 (24)가

(10) (10) (10) (23) (23)

(10) (10) (10) (23) (10)

(10) (24) (10) (14) 가 가 (10)가

5 6 3 (10) (24)

, 4 ,

7 (10) (25) (10) 가

(25)

가 가 가

(57)

1. (14) (12)가 (10) (10) (10)

(16) (18) (10) (24) (24) (10) (10)가 (1).

(23) (1) (10) (24) (10)

2. (24) (10) (1).

1 (24)

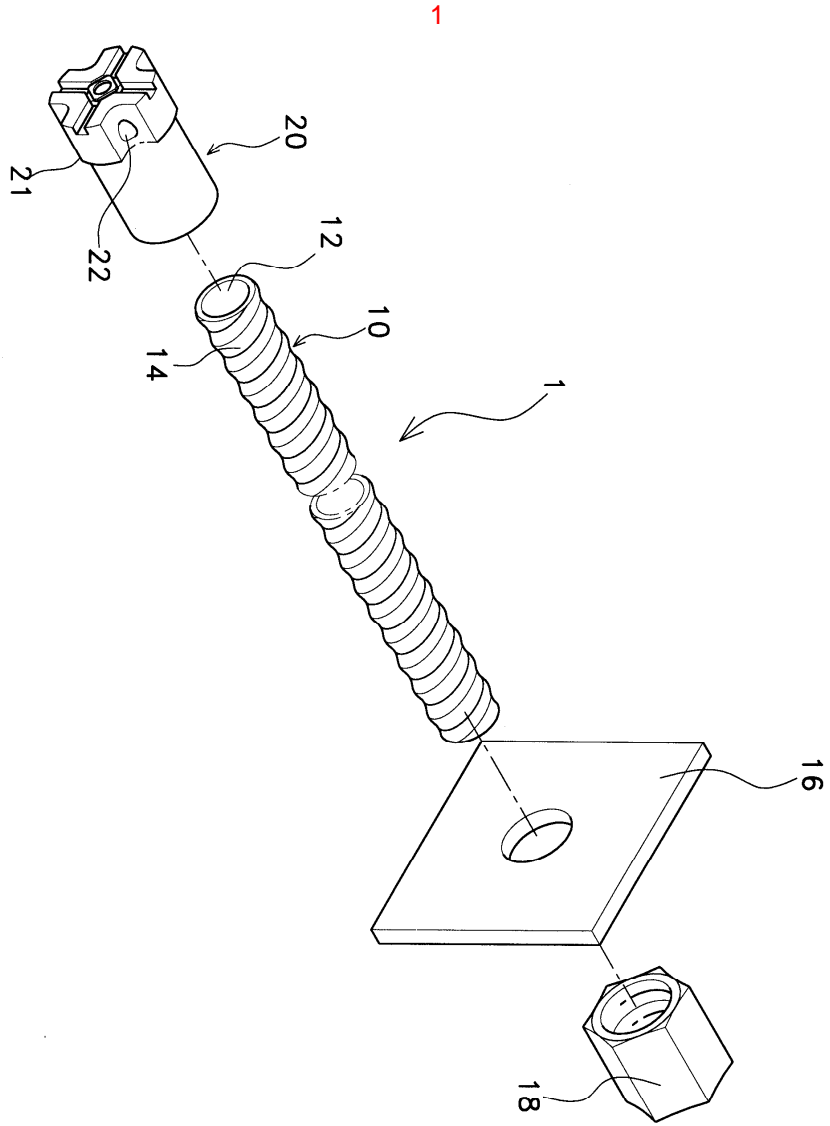

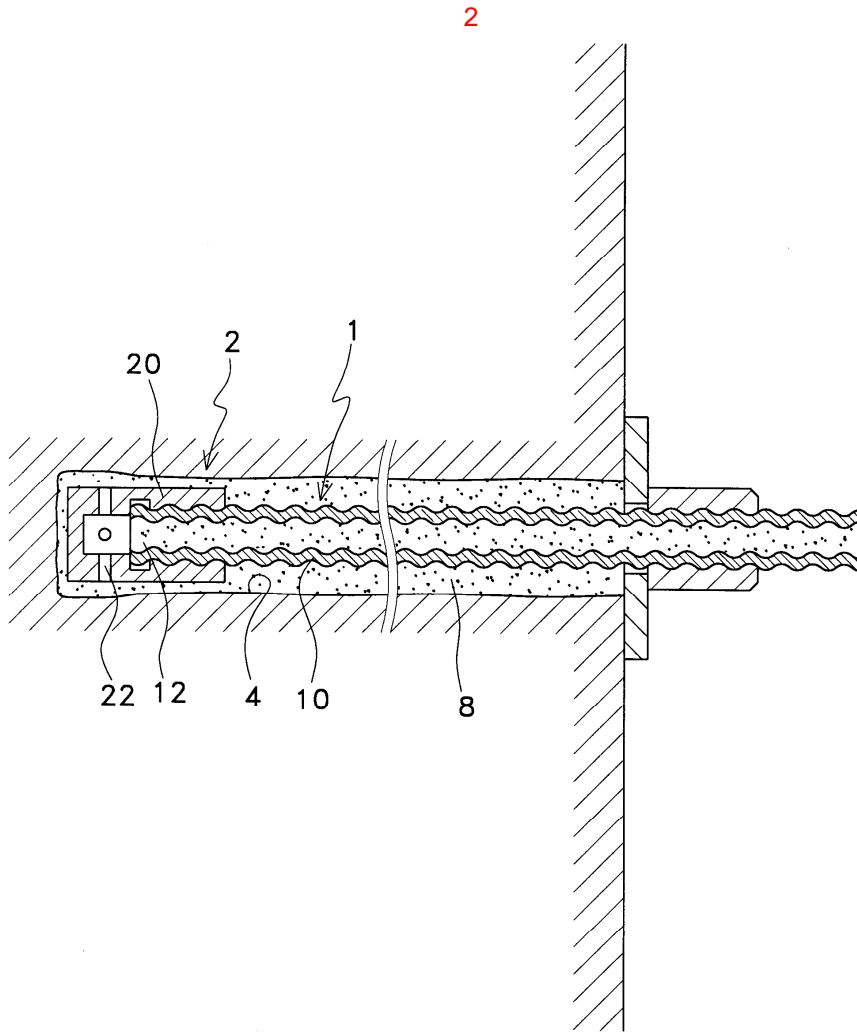

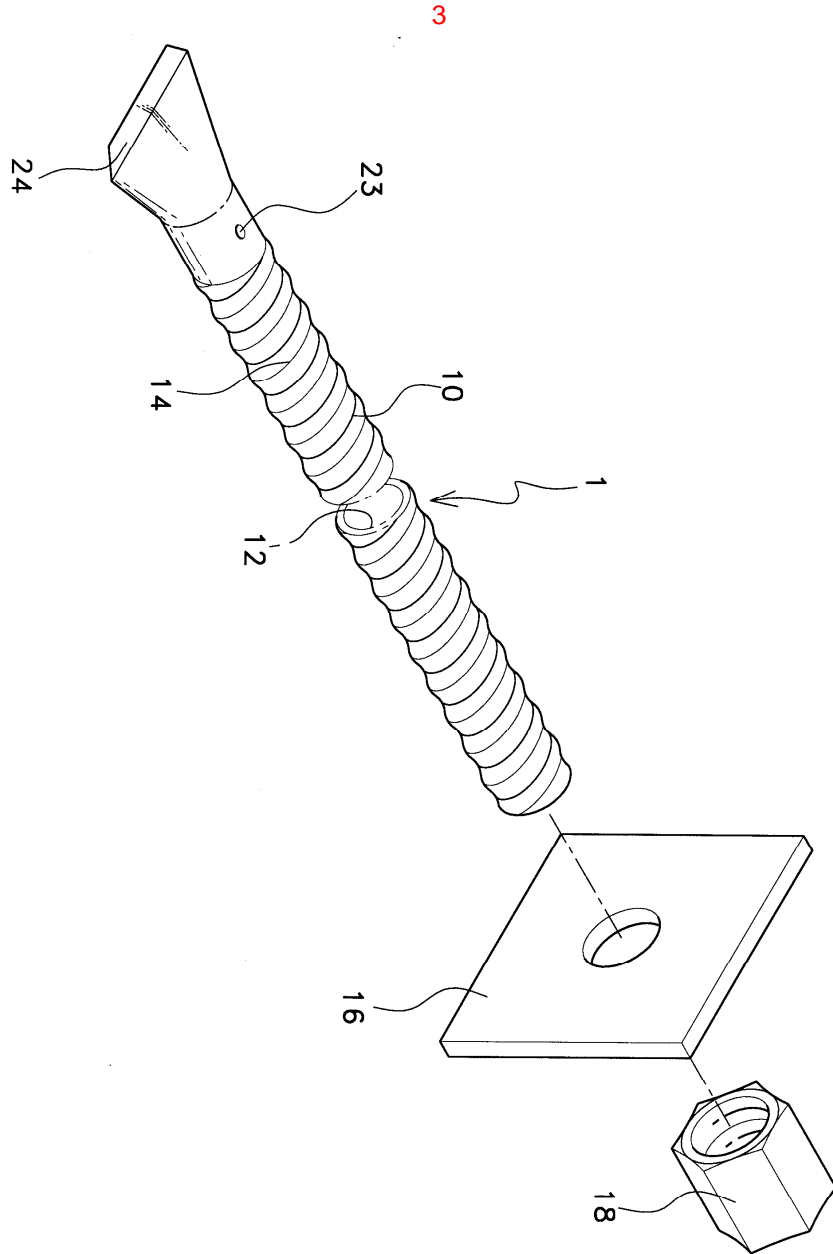

4

