

(No Model.)

2 Sheets—Sheet 1.

# L. WHITTAKER.

## GAS FURNACE FOR MELTING GLASS, IRON, &c.

No. 342,944.

Patented June 1, 1886.

Fig. 1.

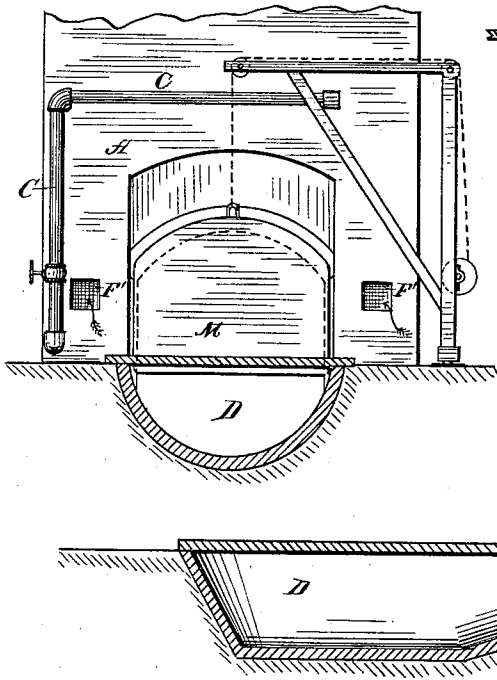

Fig. 2.

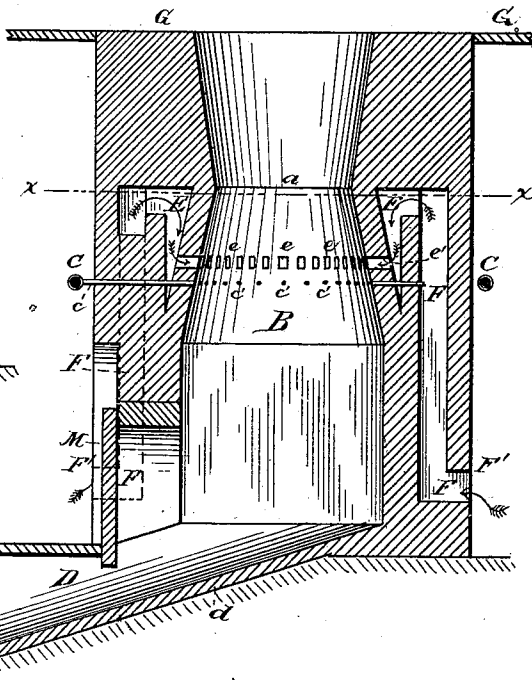

Fig. 3.

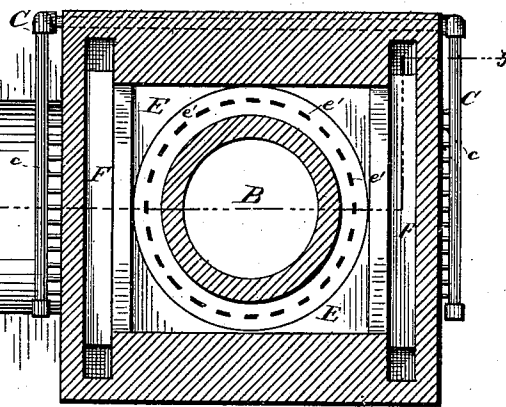
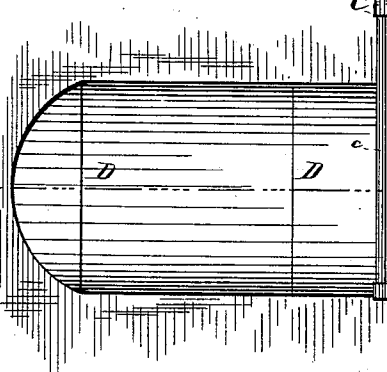
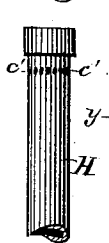

Fig. 4.



Agents:  
 Wm. Rheem.  
 Philip Mauro

Inventor.  
 Lee Whittaker by  
 J. H. [Signature]  
 Attorneys.

L. WHITTAKER.

GAS FURNACE FOR MELTING GLASS, IRON, &c.

No. 342,944.

Patented June 1, 1886.

Fig. 5.

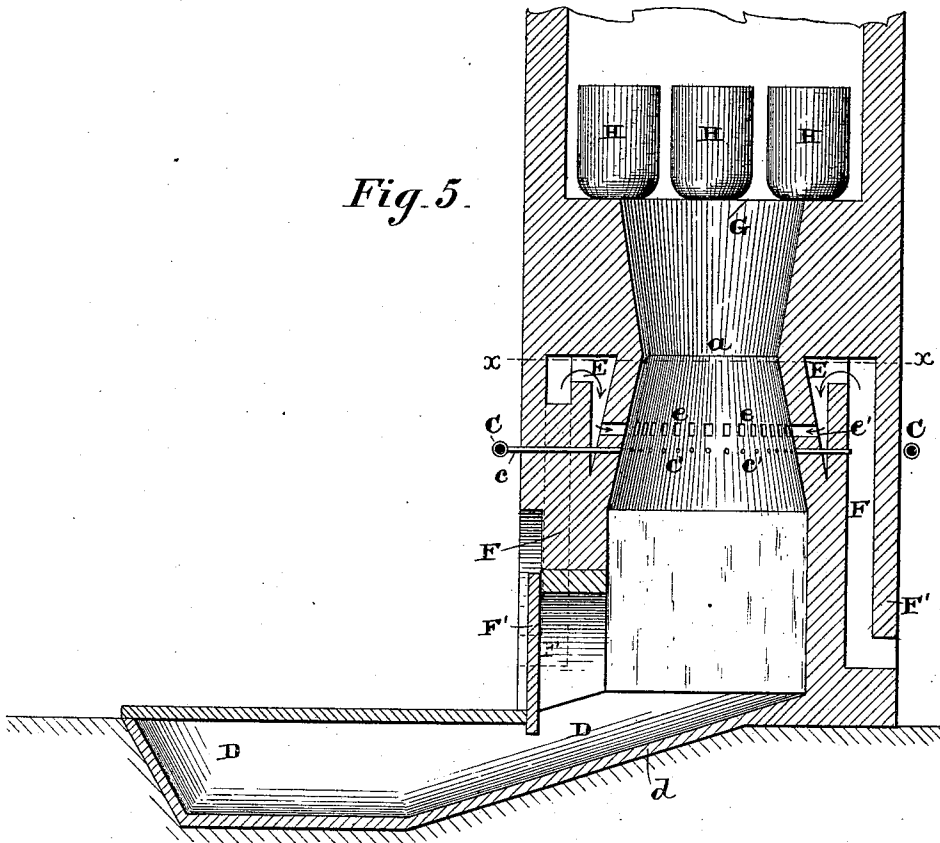

Attest:  
 Geo. T. Smallwood.  
 Philip Mauro.

Inventor:  
 Lee Whittaker.  
 By A. T. Pollok  
 his atty

# UNITED STATES PATENT OFFICE.

LEE WHITTAKER, OF ALLEGHENY CITY, PENNSYLVANIA.

## GAS-FURNACE FOR MELTING GLASS, IRON, &c.

SPECIFICATION forming part of Letters Patent No. 342,944, dated June 1, 1886.

Application filed November 30, 1885. Serial No. 184,280. (No model.)

*To all whom it may concern:*

Be it known that I, LEE WHITTAKER, of Allegheny City, in the county of Allegheny, of the State of Pennsylvania, have invented new and useful Improvements in Gas-Furnaces for Melting Glass, Iron, &c., which Improvements are fully set forth in the following specification.

This invention has reference more particularly to furnaces in which natural gas is utilized, but is also applicable to furnaces employing gaseous fuel generally.

The improvements may be applied to furnaces for melting glass, iron, or steel, and to boiler and other furnaces. It is desirable in furnaces of this kind to regulate the combustion in such manner as to secure an even intense heat without a cutting flame, which would break or crack the pots containing the material to be melted, and also in time cut a hole through the cap of the furnace. The present improvements are designed to accomplish these results. The gas is introduced into the combustion-chamber through a number of small orifices, so that the gas is spread over a wide area. The air is introduced in like manner through a number of orifices immediately above the gas-inlets. The diameter of the combustion-chamber is contracted gradually to a point a few feet above these inlets, and from that point it gradually widens to the top of the chamber. This arrangement of the inlets produces a thorough admixture of the air and gas, and the contraction of the chamber brings the fluids into more intimate contact, thereby forcing or stimulating the combustion. The force of the flame is relieved by the gradual expansion, so that at the bench or top of the combustion-chamber there is a clear, steady, and intense heat without jets or points of flame. The location of the air-inlets above the gas-orifices is found to conduce greatly to steadiness of the heat at the top of the chamber. I also provide at the bottom of the combustion-chamber a trough or pocket, into which, in case of the breakage of a pot on the bench, the molten material will be caught.

The accompanying drawings illustrate my improvements as applied to an ordinary glass-furnace, so much of the furnace being shown as is necessary for the explanation of my invention.

It will be understood that the parts not shown are of any ordinary construction.

Figure 1 is a front view of the lower part of such furnace; Fig. 2, a vertical section thereof; Fig. 3, a horizontal section, and Fig. 4 a detail view illustrating a modification. Fig. 5 is a view similar to Fig. 2, but showing more of the upper part of the furnace and the pots upon the bench. The line *xx* on Fig. 2 is the section-line of Fig. 3, and line *yy* on the latter figure is the section-line of Fig. 2.

The furnace A is provided with a door, M, and with the usual means for lifting the same, as indicated. The combustion chamber or well B is a vertical chamber circular in cross-section. The gas is conveyed to the furnace by supply-pipes C, and is admitted to the combustion chamber or well B by a series of small orifices, *c'*, connecting with the supply-pipe by a number of small branch pipes, *c*. Directly above the openings *c'* in the wall of chamber B are the air-inlets *e*. The air enters the chamber through the passages *e'* from an annular air-chamber, E, surrounding the combustion-chamber B. The air-chamber is supplied through the upright flues F, communicating with the outer air at F'. The chamber or well B is contracted gradually, as shown, to a point, *a*, which is several feet above the air and gas inlets, and from that point it gradually expands in diameter to the bench G, upon which in use the melting-pots H are placed.

The position of the air-inlets with respect to the gas-orifices is designed to secure better admixture of the air and gas and greater steadiness of combustion. The air enters at a point above the gas, but the latter, by reason of its lightness, rises more rapidly, and as both fluids issue in small jets from a great many orifices they become thoroughly mixed together. The contraction *a* also tends to bring the air and gas together, and thus force combustion up to that point. The expansion of the well or chamber B above the part *a* permits the flame to spread out, producing at the bench G a clear, intense heat, without irregularities or cutting-flames.

The pocket D is provided for recovering any glass that might otherwise be wasted through the accidental breakage of a pot H on bench G. In case of such accident, the glass would fall to the bottom of the well and flow down

incline *d* into the trough or pocket D, whence it could be removed when desired.

Instead of the arrangement of gas-jets shown in Figs. 2 and 3, a center burner—such as shown in Fig. 4—may be used, the orifices *c'* being in the outer wall of tube H, instead of in the inner wall of chamber B.

Although I have described my improvements in connection with a glass-furnace, it is evident that they could be readily and advantageously applied to furnaces of other kinds. It is also obvious that details of construction may be varied without departing from the spirit of the invention, and that some of the improvements could, if desired, be used without others.

I am aware that it has been proposed heretofore to construct a gas-furnace with air-inlets arranged above the gas-inlets, and therefore I do not claim that feature, broadly, as my invention; but

What I do claim is—

1. In a gas furnace, the combustion-chamber provided with a series of gas and air inlets, the diameter of said chamber being gradually contracted above said inlets, and again expanded toward the top of said chamber, substantially as described.

2. In a gas-furnace, the combustion-chamber having a contracted part from which the

said chamber expands in diameter both upwardly and downwardly, and provided with a series of gas and air inlets in the inclined wall of the chamber below the contracted portion, substantially as described.

3. In a gas-furnace, the combustion-chamber having a contracted part, a series of air-inlets below such contraction, and a series of gas-inlets below the air-inlets, substantially as described.

4. In a gas-furnace, the combination, with the combustion-chamber having a series of gas-inlets, of the air-chamber surrounding the combustion-chamber, and communicating therewith through a series of orifices, and the vertical flues for conveying air upwardly to said air-chamber, substantially as described.

5. The combination, with the combustion chamber or well, of the pocket or trough to one side of the furnace, and communicating with the bottom of the well by an inclined passage, substantially as described.

In testimony whereof I have signed this specification in presence of two subscribing witnesses.

LEE WHITTAKER.

Witnesses:

WM. D. HARTUPEE,  
I. O. THOMAS.