



US00D733678S

(12) **United States Design Patent**  
**Gundlach et al.**

(10) **Patent No.:** **US D733,678 S**

(45) **Date of Patent:** **\*\* Jul. 7, 2015**

(54) **AUDIO SPEAKER**

(71) Applicant: **Emo Labs, Inc.**, Waltham, MA (US)

(72) Inventors: **John David Gundlach**, Acton, MA (US); **Daniel Hedges**, Stow, MA (US); **Stefan Bokaemper**, Newton, MA (US); **Terrence Keith Jones**, Sharon, MA (US); **David Logvin**, Lowell, MA (US)

(73) Assignee: **Emo Labs, Inc.**, Wellesley, MA (US)

(\*\*) Term: **14 Years**

(21) Appl. No.: **29/477,787**

(22) Filed: **Dec. 27, 2013**

(51) **LOC (10) Cl.** ..... **14-03**

(52) **U.S. Cl.**  
USPC ..... **D14/214**

(58) **Field of Classification Search**

USPC ..... D14/167, 168, 170-172, 188, 194-196, D14/204, 207, 209.1, 210-216, 219, 221, D14/222, 224, 496; 181/143, 144, 147, 148, 181/150, 153, 157, 198, 199; 381/300-303, 381/306, 332, 333, 336, 345, 361-364, 381/386-388; 369/6-12; D10/52, 53, D10/55-57  
CPC .... B60R 11/0217; G06F 1/1688; H04M 1/03; H04M 1/035; H04R 1/02; H04R 1/06; H04R 1/021; H04R 1/025; H04R 1/026; H04R 1/028; H04R 1/105; H04R 1/323; H04R 1/403; H04R 1/2803; H04R 1/2834; H04R 5/02; H04R 7/20; H04R 9/06; H04R 9/025; H04R 2201/021; H04R 2400/00; H04R 2400/07; H04R 2499/11; H04R 2499/13; H04R 2499/15; H04S 3/00; H04S 7/30

See application file for complete search history.

(56) **References Cited**

U.S. PATENT DOCUMENTS

D183,357 S \* 8/1958 Lindenberg ..... D14/211  
2,895,062 A 7/1959 Abbott  
D188,326 S \* 7/1960 Sharp ..... D14/214  
3,057,961 A 10/1962 Turner  
3,093,710 A 6/1963 Eyck  
3,509,387 A 4/1970 Davies et al.

(Continued)

FOREIGN PATENT DOCUMENTS

CA 2396260 A1 7/2001  
CA 2610483 A1 12/2006

(Continued)

OTHER PUBLICATIONS

International Search Report and Written Opinion mailed on Jul. 18, 2014, for International Patent Application No. PCT/US14/28345, filed Mar. 14, 2014 (17 pages).

(Continued)

*Primary Examiner* — Keli L Hill

(74) *Attorney, Agent, or Firm* — Brown Rudnick LLP

(57) **CLAIM**

The ornamental design for an audio speaker, as shown and described.

**DESCRIPTION**

FIG. 1 is a front side perspective view of an audio speaker, embodying our new design;  
FIG. 2 is a front elevation view thereof;  
FIG. 3 is a rear elevation view thereof;  
FIG. 4 is a left side elevation view thereof;  
FIG. 5 is a right side elevation view thereof;  
FIG. 6 is a top plan view thereof; and,  
FIG. 7 is a bottom plan view thereof.  
All features illustrated in phantom line (i.e., dashed lines) are expressly disclaimed and form no part of the claimed design.

**1 Claim, 7 Drawing Sheets**

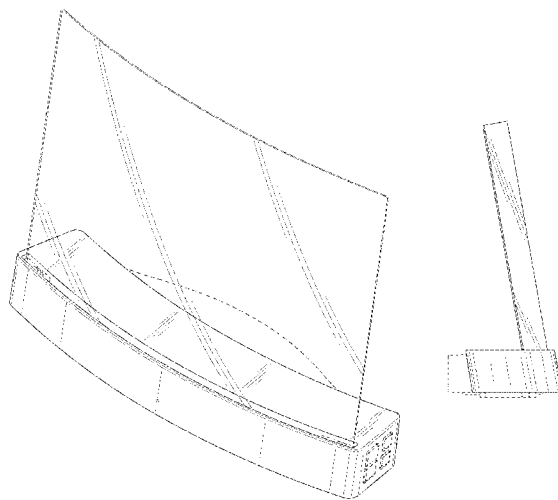

(56)

## References Cited

## U.S. PATENT DOCUMENTS

3,544,201 A	12/1970	Fowler et al.	6,023,123 A	2/2000	Petiet	
4,047,060 A	9/1977	Schafft	6,028,389 A	2/2000	Bernstein	
4,056,742 A	11/1977	Tibbetts	6,031,926 A	2/2000	Azima et al.	
4,088,915 A	5/1978	Kodama	6,058,196 A	5/2000	Heron	
4,140,203 A	2/1979	Niguchi et al.	6,060,811 A	5/2000	Fox et al.	
4,170,742 A	10/1979	Itagaki et al.	6,064,746 A	5/2000	Nakamura et al.	
4,181,865 A	1/1980	Kohyama	6,144,746 A	11/2000	Azima et al.	
4,186,323 A	1/1980	Cragg et al.	6,151,402 A	11/2000	Azima et al.	
4,198,550 A	4/1980	Matsuda et al.	6,181,797 B1	1/2001	Parrella et al.	
4,241,313 A	12/1980	Takehara	6,188,775 B1	2/2001	Azima et al.	
4,291,205 A	9/1981	Kamon et al.	6,195,440 B1	2/2001	Warnaka et al.	
4,297,185 A	10/1981	Chevreur et al.	6,198,831 B1	3/2001	Azima et al.	
4,315,557 A	2/1982	Nakaya et al.	6,215,881 B1	4/2001	Azima et al.	
4,352,961 A	10/1982	Kumada et al.	6,215,882 B1	4/2001	Heron	
4,454,386 A	6/1984	Koyano	6,215,884 B1	4/2001	Parrella et al.	
4,503,564 A	3/1985	Edelman et al.	6,218,766 B1	4/2001	Warnaka et al.	
4,571,553 A	2/1986	Yokoyama	6,243,473 B1	6/2001	Azima et al.	
4,573,189 A	2/1986	Hall	6,247,551 B1	6/2001	Heron	
4,578,613 A	3/1986	Posthuma de Boer et al.	6,278,790 B1	8/2001	Davis et al.	
4,593,160 A	6/1986	Nakamura	6,294,859 B1	9/2001	Jaenker	
4,607,145 A	8/1986	Ravinot et al.	D449,590 S *	10/2001	Lewis	D14/188
4,618,814 A	10/1986	Kato et al.	6,427,017 B1	7/2002	Toki	
4,625,138 A	11/1986	Ballato	6,437,485 B1	8/2002	Johansson	
4,625,259 A	11/1986	Krechmer et al.	6,472,797 B1	10/2002	Kishimoto	
4,638,207 A	1/1987	Radice	6,504,286 B1	1/2003	Porat et al.	
4,680,800 A	7/1987	Bank et al.	6,522,460 B2	2/2003	Bonnedal et al.	
4,751,419 A	6/1988	Takahata	6,522,760 B2	2/2003	Azima et al.	
4,807,294 A	2/1989	Iwata et al.	D472,543 S *	4/2003	Shintani	D14/211
4,847,904 A	7/1989	McShane	6,570,299 B2	5/2003	Takeshima et al.	
4,864,624 A	9/1989	Tichy	6,617,765 B1	9/2003	Lagier et al.	
4,899,390 A	2/1990	Takewa et al.	6,708,797 B2	3/2004	Long et al.	
4,969,197 A	11/1990	Takaya	6,720,708 B2	4/2004	Athanas	
4,979,219 A	12/1990	Lin	6,720,709 B2	4/2004	Porat et al.	
4,992,692 A	2/1991	Dias	6,785,393 B2	8/2004	Lipponen et al.	
4,997,058 A	3/1991	Bertagni	6,797,396 B1	9/2004	Liu et al.	
5,031,222 A	7/1991	Takaya	6,844,657 B2	1/2005	Miller et al.	
5,081,683 A	1/1992	Torgeson	6,845,166 B2	1/2005	Hara et al.	
5,115,472 A	5/1992	Park et al.	D516,059 S *	2/2006	Murphy	D14/211
5,193,119 A	3/1993	Tontini et al.	7,009,326 B1	3/2006	Matsuo et al.	
5,265,165 A	11/1993	Rauch	7,010,143 B2	3/2006	Kam	
5,283,835 A	2/1994	Athanas	7,015,624 B1	3/2006	Su et al.	
5,368,917 A	11/1994	Rehfeld et al.	7,020,302 B2	3/2006	Konishi et al.	
5,388,160 A	2/1995	Hashimoto et al.	D520,493 S *	5/2006	Amsel	D14/211
5,392,000 A	2/1995	Gillig	7,038,356 B2	5/2006	Athanas	
5,428,832 A	6/1995	Nohara et al.	7,039,206 B2	5/2006	Mellow	
5,473,214 A	12/1995	Hildebrand	7,050,600 B2	5/2006	Saiki et al.	
5,524,058 A	6/1996	Moseley	7,120,263 B2	10/2006	Azima et al.	
5,526,421 A	6/1996	Berger et al.	7,151,837 B2	12/2006	Bank et al.	
5,575,827 A	11/1996	Piniacki	7,174,025 B2	2/2007	Azima et al.	
5,608,282 A	3/1997	Wilber et al.	7,194,098 B2	3/2007	Azima et al.	
5,615,270 A	3/1997	Miller et al.	7,212,648 B2	5/2007	Saiki et al.	
5,638,454 A	6/1997	Jones et al.	7,236,602 B2	6/2007	Gustavsson	
5,638,456 A	6/1997	Conley et al.	7,274,855 B2	9/2007	Nevo et al.	
5,642,332 A	6/1997	Chang et al.	7,339,736 B2	3/2008	Trapani et al.	
5,652,801 A	7/1997	Paddock	7,536,211 B2	5/2009	Saiki et al.	
5,676,612 A	10/1997	Schellekens et al.	7,565,949 B2	7/2009	Tojo	
5,684,689 A	11/1997	Hahn	7,583,811 B2	9/2009	Wada	
5,684,884 A	11/1997	Nakaya et al.	7,788,808 B1	9/2010	Ptak	
5,705,878 A	1/1998	Lewis et al.	7,792,319 B2	9/2010	Kimura et al.	
5,711,058 A	1/1998	Frey	7,884,529 B2	2/2011	Johnson et al.	
5,736,808 A	4/1998	Szilagy et al.	7,889,601 B2	2/2011	Goodmote et al.	
5,751,827 A	5/1998	Takahashi	7,903,091 B2	3/2011	Lee et al.	
5,767,612 A	6/1998	Takeuchi et al.	D640,233 S *	6/2011	Fathollahi	D14/211
5,773,102 A	6/1998	Rehfeld	8,033,674 B1	10/2011	Coleman et al.	
5,780,958 A	7/1998	Strugach et al.	8,068,635 B2	11/2011	Carlson et al.	
5,802,195 A	9/1998	Regan et al.	D659,674 S *	5/2012	Fathollahi	D14/211
5,825,902 A	10/1998	Fujishima	8,189,851 B2	5/2012	Booth et al.	
5,828,768 A	10/1998	Eatwell et al.	D671,524 S *	11/2012	Fathollahi	D14/211
5,856,956 A	1/1999	Toki	8,395,371 B2	3/2013	Govil	
5,867,302 A	2/1999	Fleming	D681,008 S *	4/2013	Fathollahi	D14/214
5,901,231 A	5/1999	Parrella et al.	D724,555 S *	3/2015	Cha et al.	D14/126
5,965,249 A	10/1999	Sutton et al.	2001/0026626 A1	10/2001	Athanas	
5,973,441 A	10/1999	Lo et al.	2001/0038701 A1	11/2001	Corynen	
5,977,688 A	11/1999	Utsunomiya et al.	2001/0052627 A1	12/2001	Takahashi et al.	
6,003,766 A	12/1999	Azima et al.	2002/0001392 A1	1/2002	Isono et al.	
			2002/0044668 A1	4/2002	Azima	
			2002/0153194 A1	10/2002	Pocock et al.	
			2003/0161479 A1	8/2003	Yang et al.	
			2004/0037441 A1	2/2004	Konishi et al.	

(56)

## References Cited

## U.S. PATENT DOCUMENTS

2004/0189151	A1	9/2004	Athanas	
2004/0228501	A1	11/2004	Saiki et al.	
2005/0053257	A1	3/2005	Johnson et al.	
2005/0069430	A1	3/2005	Sugahara	
2005/0180592	A1	8/2005	Miura	
2005/0232435	A1	10/2005	Stothers et al.	
2005/0288039	A1	12/2005	Liou	
2006/0066803	A1	3/2006	Aylward et al.	
2006/0269087	A1	11/2006	Johnson et al.	
2006/0290236	A1	12/2006	Ikehashi	
2007/0000720	A1	1/2007	Noro et al.	
2007/0003100	A1	1/2007	Liu	
2007/0007859	A1	1/2007	Weber	
2007/0092088	A1	4/2007	Chang	
2007/0133837	A1	6/2007	Suzuki et al.	
2007/0223714	A1	9/2007	Nishikawa	
2007/0243364	A1	10/2007	Maekawa et al.	
2007/0260019	A1	11/2007	Ohme et al.	
2007/0297620	A1	12/2007	Choy	
2008/0007829	A1	1/2008	Mizushima et al.	
2008/0138541	A1	6/2008	Moto et al.	
2008/0138543	A1	6/2008	Hoshino et al.	
2008/0273720	A1	11/2008	Johnson et al.	
2009/0136690	A1	5/2009	Sasada	
2009/0190791	A1	7/2009	Unruh et al.	
2009/0200896	A1	8/2009	Morris et al.	
2009/0285431	A1	11/2009	Carlson et al.	
2009/0317592	A1	12/2009	Yoshitomi et al.	
2010/0224437	A1	9/2010	Booth et al.	
2010/0322455	A1	12/2010	Carlson	
2011/0026757	A1	2/2011	Takahashi et al.	
2011/0033074	A1	2/2011	Chang et al.	
2011/0044476	A1	2/2011	Burlingame et al.	
2011/0163999	A1*	7/2011	Lin	345/176
2011/0274283	A1	11/2011	Athanas	
2012/0186903	A1	7/2012	Booth et al.	

## FOREIGN PATENT DOCUMENTS

EP	1395083	A2	3/2004
FR	2649575	A1	1/1991
GB	1369241	A	10/1974
JP	52045923		4/1977
JP	5615182		7/1979
JP	57181298		11/1982
JP	58034699		3/1983
JP	58182999		10/1983
JP	63176098		7/1988
JP	63176099		7/1988
JP	63250995		10/1988
JP	64029097		2/1989
JP	334391		4/1991
JP	6217296		8/1994
JP	8102988		4/1996
JP	9298798		11/1997
JP	10094093		4/1998
JP	10327491		12/1998
JP	11215578		8/1999
JP	2000350285	A	12/2000
JP	2000356808	A	12/2000
JP	2001500258	A	1/2001
JP	2001503552	A	3/2001
JP	2001320798	A	11/2001
JP	2003529976	A	10/2003
JP	2004147286	A	5/2004
JP	2005105892	A	4/2005
JP	2008514867	A	5/2008
JP	4140999	B2	8/2008
JP	2010283867	A	12/2010
JP	2012134998	A	7/2012
JP	5122793	B2	1/2013
KR	2008-0080258	A	9/2008
KR	10-1260543		5/2013
WO	96/35313	A1	11/1996

WO	97/09844	A1	3/1997
WO	97/09846	A1	3/1997
WO	98/10252	A2	3/1998
WO	98/28942	A1	7/1998
WO	01/52400	A1	7/2001
WO	2004/030406	A1	4/2004
WO	2006/130731	A2	12/2006
WO	2006/130782	A2	12/2006
WO	2009/067669	A1	5/2009
WO	2009/151892	A1	12/2009

## OTHER PUBLICATIONS

Backman, 1999, "Improving Piezoelectric Speakers with Feedback," Proc. AES Convention 106, 10 pages.

Beck, 2006, "Hysteresis Characterization Using Charge Feedback Control for a LIPCA Device," Proc. SPIE Int. Soc. For Opt. Eng. 6170, 10 pages.

Furutani, 1998, "Displacement control of piezoelectric element by feedback of induced charge," Nanotechnology 9:93-98.

Decision of Dismissal of Amendment in Japanese Patent Application No. 2007-066645, dated Sep. 27, 2011, 6 pages.

EPO Search Report for European App No. 01901776.3, dated Nov. 2, 2005, 5 pages.

EPO Supplementary Partial Search Report for European App No. 01901776.3, dated Apr. 26, 2005, 6 pages.

EPO Supplementary Search Report for European App No. 01901776.3, dated Aug. 3, 2005, 6 pages.

International Preliminary Examination Report for International Patent App PCT/US01/00349, dated Nov. 22, 2002, 4 pages.

International Preliminary Report on Patentability for International Patent App PCT/US06/21189, dated Dec. 6, 2007, 7 pages.

International Search Report and Written Opinion for International Patent App PCT/US01/00349, dated Apr. 30, 2001, 6 pages.

International Search Report and Written Opinion for International Patent App PCT/US06/21189, dated Nov. 21, 2006, 8 pages.

International Search Report and Written Opinion for International Patent App PCT/US06/21311, dated Sep. 5, 2007, 8 pages.

International Search Report and Written Opinion for International Patent App PCT/US08/84359, dated Jan. 27, 2009, 6 pages.

International Search Report and Written Opinion for International Patent App PCT/US09/44544, dated Nov. 13, 2009, 7 pages.

International Search Report and Written Opinion for International Patent App PCT/US10/45628, dated Oct. 6, 2010, 10 pages.

International Search Report and Written Opinion for International Patent App PCT/US11/44564, dated Oct. 31, 2011, 9 pages.

International Search Report for International Patent App PCT/GB97/03090, dated Jun. 9, 1998, 5 pages.

Azom.com, A to Z of Materials, Cellulose Acetate—CA, added May 7, 2001, available at <http://azom.com/article.aspx?ArticleID=383>, retrieved Mar. 16, 2012, 2 pages.

Edmund Optics Worldwide, "TECHSPEC Linear Polarizing Laminated Film," available at <http://www.edmundoptics.com/onlinecatalog/displayproduct.cfm?productID=1912>, retrieved Dec. 3, 2009, 2 pages.

Harris, 1997, "The distributed-mode loudspeaker (DML) as a broadband acoustic radiator," Audio Engineering Society Preprint 4526 (D-6); Presented at the 103rd Convention 1997 Sep. 26-29, New York, 5 pages.

International Standard, 2006, "Adhesives—Peel test for a flexible-bonded-to-rigid test specimen assembly—Part I: 90 degree peel" ISO Reference No. ISO/FDIS 8510-1:2006 (E), 14 pages.

Kugel, "Bimorph-based piezoelectric air acoustic transducer: model," Sensors and Actuators A: Physical 69(3): 234-42.

PolymerProcessing.com, Poly(ethylene terephthalate), copyrighted 2000, 2001, available at <http://www.polymerprocessing.com/polymers/PET.html>, retrieved Mar. 16, 2012, 2 pages.

The Engineering Toolbox, Elastic Properties and Young Modulus for some Materials, available at [http://www.engineeringtoolbox.com/young-modulus-d\\_417.html](http://www.engineeringtoolbox.com/young-modulus-d_417.html), retrieved Mar. 16, 2012, 4 pages.

(56)

**References Cited**

OTHER PUBLICATIONS

The Physics Classroom, "Light Waves and Color—Lesson 1, How do we know light behaves as a wave?" available at [http://www.](http://www.physicsclassroom.com/Class/light/U12L1a.cfm)

[physicsclassroom.com/Class/light/U12L1a.cfm](http://www.physicsclassroom.com/Class/light/U12L1a.cfm), retrieved Dec. 3, 2009, 2 pages.

\* cited by examiner

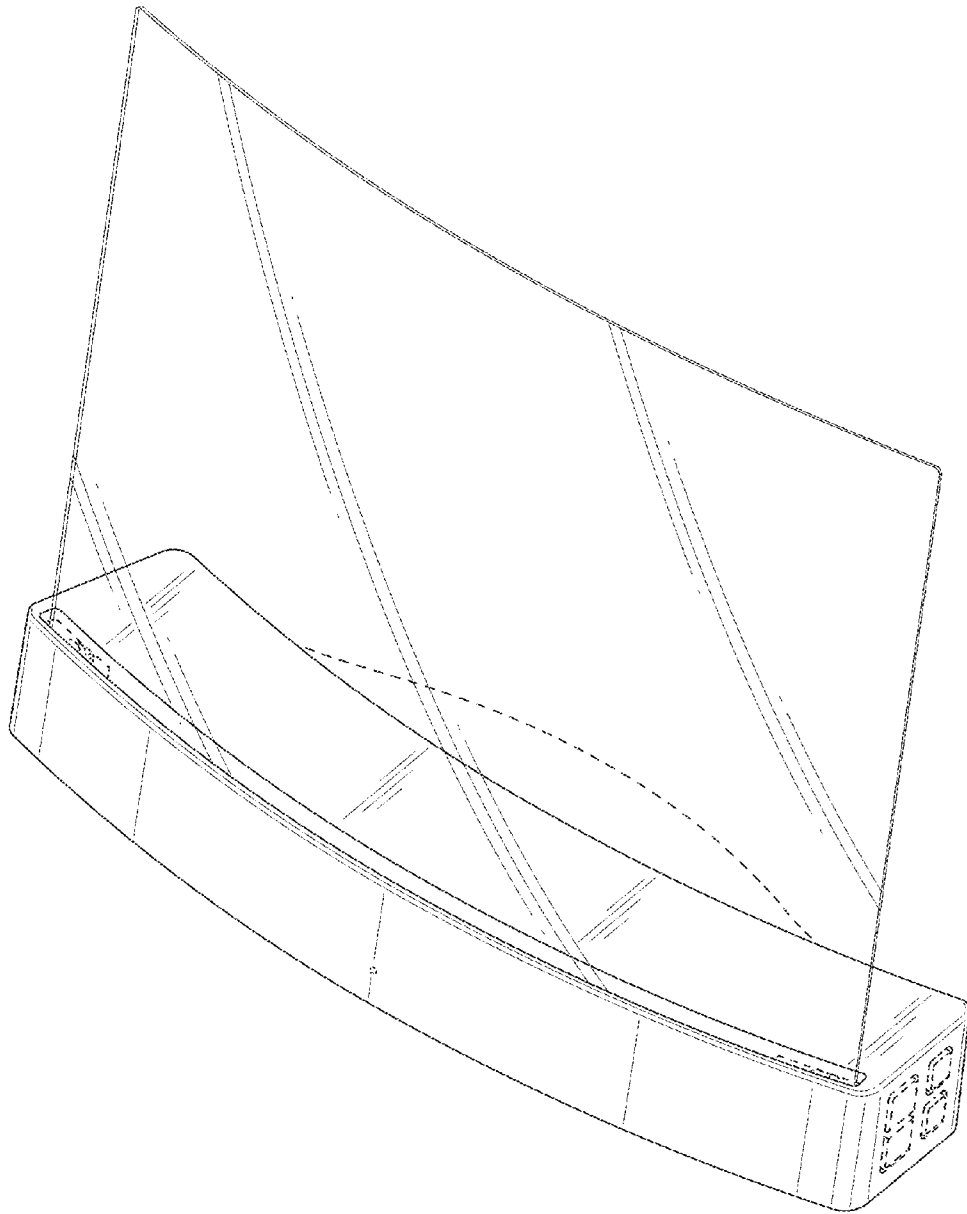

FIG.1

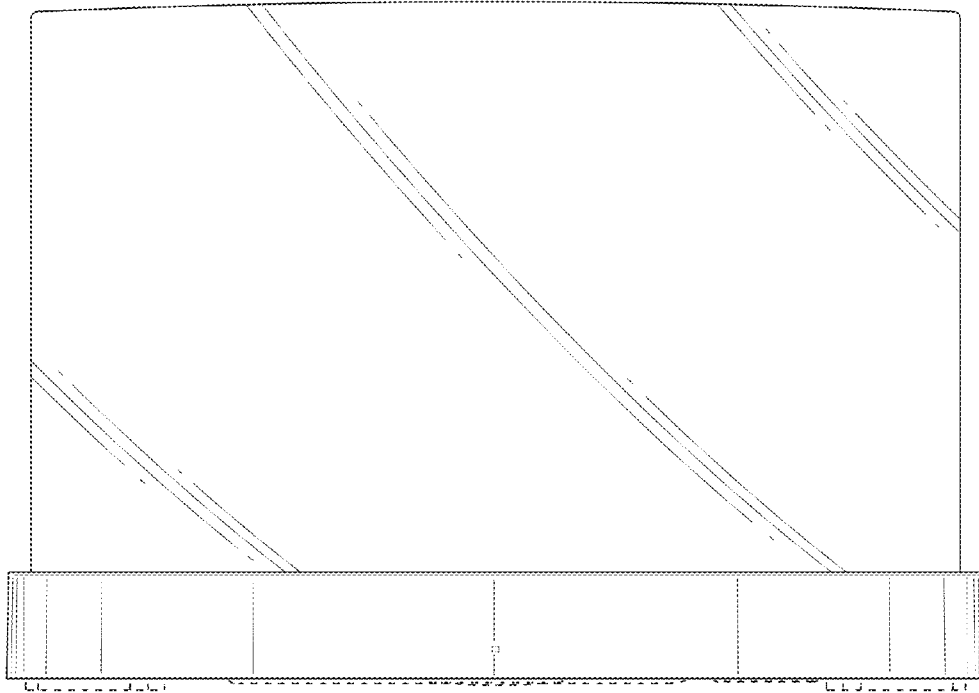

FIG.2

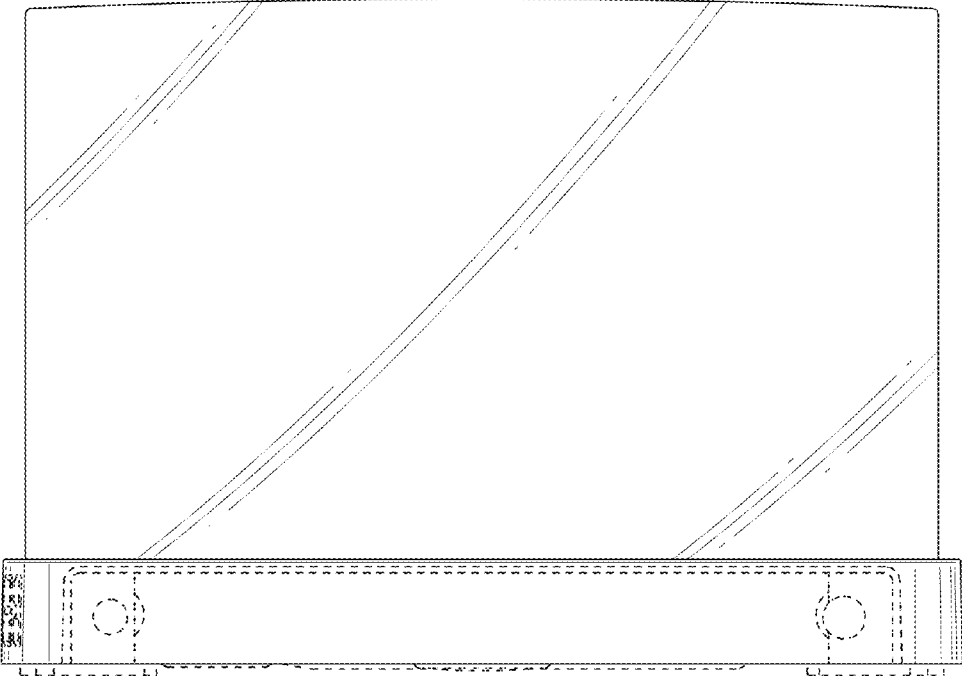

FIG.3

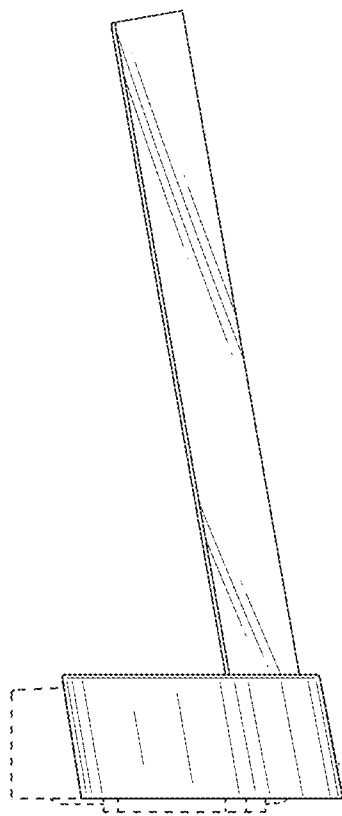

FIG.4

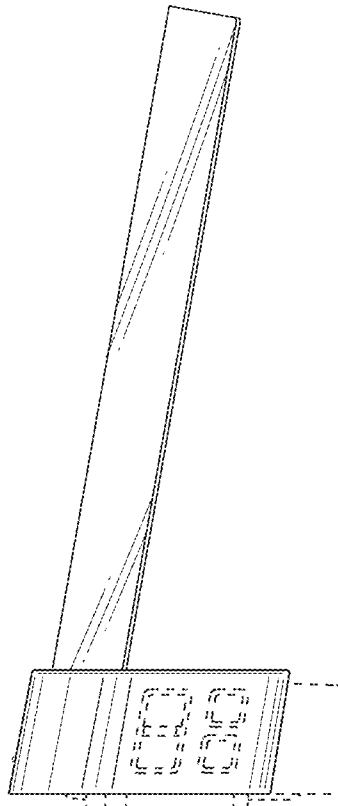

FIG.5

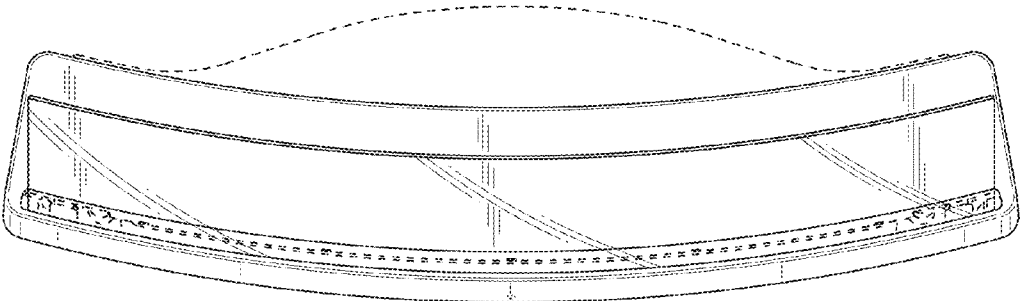

FIG.6

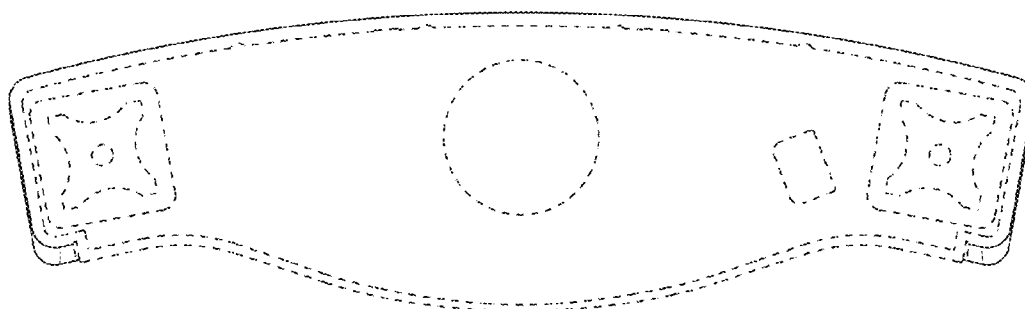

FIG.7