

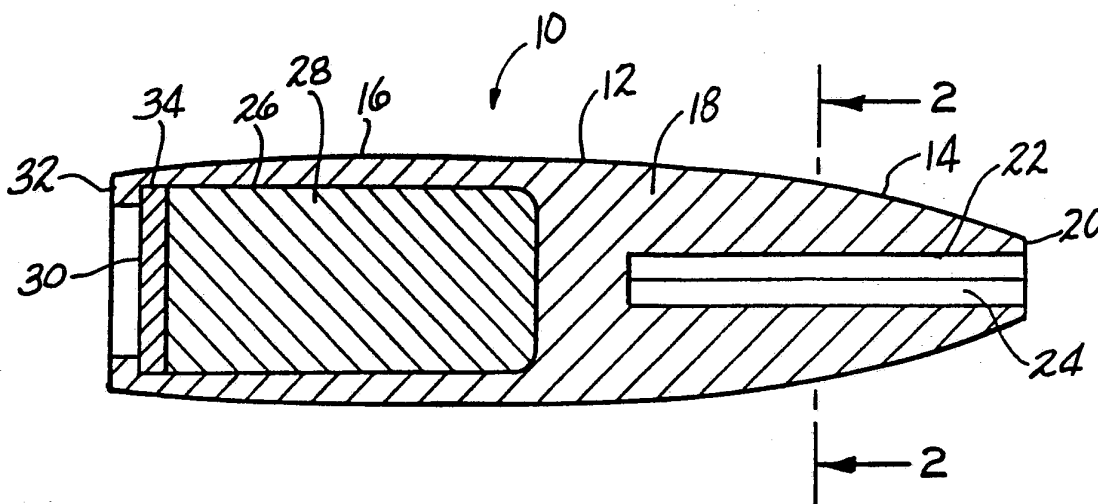

INTERNATIONAL APPLICATION PUBLISHED UNDER THE PATENT COOPERATION TREATY (PCT)

| | | |
|---|------------------|--|
| <p>(51) International Patent Classification ⁵ : F42B 12/34</p> | <p>A1</p> | <p>(11) International Publication Number: WO 93/07438 (43) International Publication Date: 15 April 1993 (15.04.93)</p> |
| <p>(21) International Application Number: PCT/US92/08055 (22) International Filing Date: 21 September 1992 (21.09.92) (30) Priority data: 772,183 7 October 1991 (07.10.91) US (71) Applicant: OLIN CORPORATION [US/US]; 350 Knotter Drive, P.O. Box 586, Cheshire, CT 06410-0586 (US). (72) Inventors: CORZINE, Alan, J. ; 419 East Alton Street, Marine, IL 62061 (US). EBERHART, Gerald, E. ; 311 Old Bethalto Road, Bethalto, IL 62010 (US). (74) Agents: BURDICK, Bruce, E. et al.; Olin Corporation, 350 Knotter Drive, P.O. Box 586, Cheshire, CT 06410-0586 (US).</p> | | <p>(81) Designated States: AU, BB, BG, BR, CA, CS, FI, HU, JP, KP, KR, LK, MG, MN, MW, NO, PL, RO, RU, SD, European patent (AT, BE, CH, DE, DK, ES, FR, GB, GR, IE, IT, LU, MC, NL, SE), OAPI patent (BF, BJ, CF, CG, CI, CM, GA, GN, ML, MR, SN, TD, TG). Published <i>With international search report.</i></p> |

(54) Title: HUNTING BULLET WITH REDUCED ENVIRONMENTAL LEAD EXPOSURE



(57) Abstract

A controlled expanding small caliber bullet (10) is disclosed which comprises a unitary metal body (12) of generally H-shaped cross section having an ogival nose portion (14), a cylindrical heel portion (16) behind the nose portion (14), and an integral transverse partition (18) therebetween. The nose portion (14) has an empty hollow point (20) formed by a forwardly open central blind bore (22). The heel portion (16) has a rearwardly open cavity (26) filled with a dense material (28) such as lead. The cavity (26) is closed behind the lead core by a solid disk (30) crimped into mechanical engagement with the heel portion (16) of the metal body (12).

FOR THE PURPOSES OF INFORMATION ONLY

Codes used to identify States party to the PCT on the front pages of pamphlets publishing international applications under the PCT.

| | | | | | |
|----|--------------------------|----|--|----|--------------------------|
| AT | Austria | FR | France | MR | Mauritania |
| AU | Australia | GA | Gabon | MW | Malawi |
| BB | Barbados | GB | United Kingdom | NL | Netherlands |
| BE | Belgium | GN | Guinea | NO | Norway |
| BF | Burkina Faso | GR | Greece | NZ | New Zealand |
| BG | Bulgaria | HU | Hungary | PL | Poland |
| BJ | Benin | IE | Ireland | PT | Portugal |
| BR | Brazil | IT | Italy | RO | Romania |
| CA | Canada | JP | Japan | RU | Russian Federation |
| CF | Central African Republic | KP | Democratic People's Republic of Korea | SD | Sudan |
| CG | Congo | KR | Republic of Korea | SE | Sweden |
| CH | Switzerland | LJ | Liechtenstein | SK | Slovak Republic |
| CI | Côte d'Ivoire | LK | Sri Lanka | SN | Senegal |
| CM | Cameroon | LU | Luxembourg | SU | Soviet Union |
| CS | Czechoslovakia | MC | Monaco | TD | Chad |
| CZ | Czech Republic | MG | Madagascar | TG | Togo |
| DE | Germany | ML | Mali | UA | Ukraine |
| DK | Denmark | MN | Mongolia | US | United States of America |
| ES | Spain | | | VN | Viet Nam |
| FI | Finland | | | | |

-1-

HUNTING BULLET WITH REDUCED
ENVIRONMENTAL LEAD EXPOSURE

This invention generally relates to hunting bullets and more particularly to a bullet having a hollow point.

Hunting bullets are generally small caliber, i.e. less than .50 caliber. They generally have a hollow point or soft metal nose portion to enhance energy absorption within the target animal tissue. Lead hollow point bullets have been marketed successfully for years. Lead hollow point bullets have one serious drawback. They all tend to upset and expand greatly within a short penetration distance and are not suitable for deep penetration. A hollow point, jacketed mushrooming bullet is disclosed in U. S. Patent No. 1,633,168.

Soft point bullets such as the well know Nosler partition bullet, disclosed in U. S. Patent No. 3,003,420 are utilized where deep penetration is required. Current soft point bullets expose lead and lead oxidation products to the environment after expansion.

Hunting bullets made primarily of a metal harder than lead have also been produced in order to achieve deep penetration with maximum tissue cutting action without splintering the bullet into pieces. For example, in U. S. Patent No. 4,044,685, a jacketless bullet having a solid cylindrical copper alloy portion and a hollow nose portion filled with lead or other plastic deformable material is disclosed. This bullet is basically a hard metal hollow point bullet with

-2-

axial grooves in the interior walls of the lead filled hollow point to provide sharp cutting flags during expansion in the target. These flags enhance cutting of the surrounding tissue as the expanding projectile passes through. This prior art bullet design suffers from having a reduced mass due to the absence of lead in the body of the projectile which limits its impact energy. In addition, it carries a substantial amount of lead in the nose which is exposed to the environment and can wash off upon expansion.

Another recent patent, 4,655,140 discloses a partition type bullet similar to the Nosler partition bullet mentioned above. The hollow nose has oblique grooves in the outer surface of the ogive. A lead insert is disposed in the nose and a lead core is provided behind a central partition portion of the copper alloy partition bullet. Again, the lead disposed in the nose of the bullet is externally exposed upon expansion and deforms or upsets in a conventional manner upon impact. Further, the lead core behind the partition is exposed to the environment to the rear. Thus, upon impact in a target animal, a substantial amount of lead is exposed as well as washed into the adjacent tissues during bullet passage.

A lead-free bullet for hunting is disclosed in U. S. Patent No. 4,685,397. This bullet is a solid one piece hollow point projectile made of tombac or copper. Closing the front end of the blind bore in the nose of the projectile is a steel plug which has wedge shaped ribs. Upon expansion, the steel plug is forced rearward into the central bore. The ribs cause the nose portion to split and curl backwards as curling petals which provide multiple cutting surfaces to lacerate tissue. However, this bullet has low mass and

insufficient mass for deep penetration within a target.

Accordingly, there is still a need for a deep penetrating expanding bullet that does not permit exposure of lead while still providing substantial
5 tissue damage.

Accordingly, it is an object of the present invention to provide a small caliber bullet which minimizes the potential of airborne environmental lead contamination.

10 It is another object of the present invention to provide a bullet with an encapsulated lead core which minimizes contamination of animal tissue by eliminating lead exposure, lead wash and jacket fragmentation.

It is a still further object of the present
15 invention to provide a small caliber bullet which has no frontal lead wash during expansion.

It is a still further object of the present invention to provide a small caliber bullet which has improved impact trauma associated with penetration of
20 the bullet into soft body tissue.

The bullet in accordance with the present invention is a controlled upsetting small caliber bullet comprising a unitary metal body of generally H-shaped axial cross section. The bullet has an ogival nose
25 portion, a generally cylindrical heel portion behind the nose portion, and an integral partition portion therebetween. The body of the bullet is preferably made of a copper alloy such as brass or other ductile metal.

30 The nose has an unfilled hollow point formed by a rearwardly extending central blind bore extending from the front tip axially rearwardly approximately the full length of the nose portion. The nose terminates at a transverse partition between the nose portion and the

-4-

heel portion. This transverse partition may support an external circumferential cannellure or groove for crimping the projectile into a cartridge case.

5 The heel portion may be straight or boattailed and has a rearwardly opened cavity which is filled with a core material which is more dense than the metal body. For example, the core material may be lead which is poured as a liquid into the preformed cavity in the heel portion, or a solid slug of lead which is swaged
10 into the heel.

The core may also be tungsten, depleted uranium, bismuth, other heavy metal or a sintered material. The rear opening of the heel portion is closed by a flat disk of non metallic material or metals such as ferrous
15 or non-ferrous materials, copper, brass, or other material identical to or similar to that of the metal body. This disk has an annular outer flange which is crimped into mechanical engagement with a rim portion of the heel portion to lock the core within the cavity.

20 The lead or other heavy metal core is thus completely enclosed within the bullet such that upon expansion of the bullet in soft body tissue, the nose portion upsets, i.e. peels back in several discrete petals which terminate at the partition portion. The
25 core remains completely enclosed. Thus, upon impact there is controlled expansion of the bullet. In addition, because the bullet body is made of a ductile metal such as copper, brass, etc., the petals form sharp cutting edges which, because of the rotational
30 momentum of the bullet, cause substantial cutting of adjacent body tissue as the upset bullet passes through. In addition, no lead is exposed upon launch or upon impact.

The bullet of the invention may be advantageously used in pistol and rifle ammunition for both hunting and law enforcement purposes. In addition, as lead is not exposed, this bullet is desirable for use in indoor shooting ranges.

Figure 1 is a longitudinal sectioned view of a bullet constructed in accordance with the present invention.

Figure 2 is a transverse sectional view through the bullet shown in Figure 1 taken along the line 2-2.

Figure 3 is a side view of a bullet constructed in accordance with the invention after upset in body tissue.

Figure 4 is a longitudinal sectional view of an alternative heel portion of the bullet according to the invention.

A controlled expanding or mushrooming small caliber bullet constructed in accordance with the present invention is illustrated in Figure 1. Bullet 10 has a unitary metal body 12 of generally H-shaped axial cross section. The bullet has an ogival nose portion 14, a generally cylindrical heel portion 16 and an integral transverse partition portion 18 therebetween tandemly arranged along a central axis therethrough.

The nose portion 14 terminates at its forward end in an annular tip 20 formed around a rearwardly extending forwardly open central blind bore 22. The central bore 22 extends rearwardly to the partition 18. The blind bore 22 may have a circular transverse cross section or that of a polygon. A square transverse cross section is shown in Figure 2 created by axially extending flat side walls 24. A polygon is preferred as the corners of the polygon provide stress concentrators during upset to predictably form the petals as shown in Figure 3.

-6-

The heel portion 16 has a rearwardly open cavity 26 which contains a core 28 of lead, depleted uranium, tungsten, other heavy metal, or sintered material which is heavier than the metal of the unitary metal body 12. This core 28 provides the heavy mass necessary to achieve deep penetration of the bullet upon target impact. However, when lead is used as the core material, the lead must be sealed from the environment. A closure disk 30, positioned behind the core 28, mechanically engages a rim 32 of the heel portion 16 in order to seal the lead from the environment. The core 28 may also be made of powdered tungsten particles which can be held together as a solid body by a suitable binder such as plastic.

The rim 32 is crimped over a radially outward extending flange portion 34 of the disk 30 so as to enclose the core 28. This disk 30 may simply be a flat disk with the rim 32 crimped thereover as shown in Figure 1 or may have a hat shaped disk 30A as shown in Figure 4 forming a flat rear surface on the bullet 10. This disk 30 is preferably made of the same material as the unitary metal body 12 in order to minimize the chance of forming a galvanic cell which could deleteriously promote corrosion of the bullet body and/or the core material and adversely affect the propellant in the cartridge case. Alternatively, the disk 30 may be made of a nonconductive material such as a plastic.

The positioning of the transverse partition 18 must be so chosen so that the center of pressure and the center of mass are optimized to preclude the tendency of the bullet to tumble during flight. In this regard, the separation distance between the center of pressure

-7-

and the center of mass should preferably be between .5 and 1 calibers.

While the present invention has been described above with reference to particular embodiments thereon, 5 it is apparent that many changes, modification, and variations can be made without departing from the inventive concept disclosed herein. Accordingly, it is intended to embrace all such changes, modifications, and variations that fall within the broad scope of the 10 appended claims.

WHAT IS CLAIMED IS:

1. A controlled expanding small caliber bullet (10) characterized by:
 - a unitary metal body (12) of generally H shaped axial cross section having an ogival nose portion (14),
5 a generally cylindrical heel portion (16) behind said nose portion and an integral partition (18) therebetween along a central axis therethrough;
said nose portion having an empty hollow point (20)
10 formed by a rearwardly extending forwardly open completely empty central blind bore (22) having axially parallel flat internal sidewalls (24);
said heel portion (16) having a rearwardly open cavity (26) therein filled with a dense material (28)
15 more dense than said metal body, said cavity (26) being closed by a solid disk (30) positioned axially behind said dense metal material (28) in engagement with said metal body (12).
2. The bullet (10) according to claim 1
20 characterized in that said blind bore (22) in said nose portion (14) has a polygonal radial cross section.
3. The bullet (10) according to claim 2 characterized in that said bore (22) has a square radial cross section.
- 25 4. The bullet (10) according to claim 1 characterized in that said metal body (12) is a copper alloy and said dense metal (28) is lead.

5. The bullet (10) according to claim 1 characterized in that said heel portion (16) further comprises said disk (30) having a flange portion (34) in interference relation with a rim (32) of said heel portion (16) so as to enclose and secure said dense material (28) within said body (12).

6. The bullet (10) according to claim 5 characterized in that said disk (20) has a radially outward extending annular flange (24) engaging an inwardly crimped annular rim (32) of said heel portion (16) to lock said dense material (28) and said disk (30) to said metal body (12).

7. The bullet (10) according to claim 5 characterized in that said metal body (12) is a copper alloy and said dense metal (28) is tungsten.

8. The bullet (10) according to claim 7 characterized in that said disk (30) has an outwardly extending annular flange (34) engaging an inwardly crimped annular rim (32) of said heel portion (16) to lock said dense material (28) and said disk to said metal body (12).

9. The bullet (10) according to claim 8 characterized in that said dense material (28) is a solid body of powdered tungsten particles.

-10-

10. A controlled expanding small caliber bullet (10) characterized by:

a unitary metal body (12) of generally H shaped axial cross section having an ogival nose portion (14),
5 a generally cylindrical heel portion (16) behind said nose portion (14) and an integral partition (18) therebetween along a central axis therethrough;

said nose portion (14) having an empty hollow point (20) formed by a rearwardly extending forwardly open
10 completely empty central blind bore (22), said blind bore (22) having axially flat internal sidewalls (24) and a polygonal radial cross section;

said heel portion (16) having a rearwardly open cavity (26) therein filled with a dense material (28)
15 more dense than said metal body (12), said cavity (26) being closed by a solid disk (30) positioned axially behind said dense metal material (28) and crimped into mechanical engagement with said metal body (12), said
20 disk (30) having a flange portion (34) in interference relation with a rim (32) of said heel portion (16) so as to enclose and secure said dense material (28) within said body (12).

11. The bullet (10) according to claim 10
25 characterized in that said bore (22) has a square radial cross section.

12. The bullet (10) according to claim 11
characterized in that said metal body (12) is a copper alloy and said dense metal (28) is lead.

13. The bullet (10) according to claim 12
30 characterized in that said disk (30) is made of the same metal as said body (12).

-11-

14. The bullet (10) according to claim 13
characterized in that said disk (30) further comprises
a central raised portion (30A) having a thickness the
same as the rim (32) crimped onto said flange portion
5 (34) so as to form a smooth transverse rear end surface
on said bullet.

INTERNATIONAL SEARCH REPORT

International application No.
PCT/US92/08055

A. CLASSIFICATION OF SUBJECT MATTER

IPC(5) :F42B 12/34

US CL :102/509

According to International Patent Classification (IPC) or to both national classification and IPC

B. FIELDS SEARCHED

Minimum documentation searched (classification system followed by classification symbols)

U.S. : 102/501,507,508,510,514,515,516,517

Documentation searched other than minimum documentation to the extent that such documents are included in the fields searched

Electronic data base consulted during the international search (name of data base and, where practicable, search terms used)

US PAT (Projectile# or Bullet#) and Tungsten

C. DOCUMENTS CONSIDERED TO BE RELEVANT

| Category* | Citation of document, with indication, where appropriate, of the relevant passages | Relevant to claim No. |
|-----------|--|-----------------------|
| A | US, A, 219,840 (WINCHESTER) 23 September 1879. | |
| A | US, A, 338,849 (LORENZ) 30 March 1886. | |
| A | US, A, 1,135,357 (CLYNE) 13 April 1915. | |
| A | US, A, 1,328,334 (NEWTON) 20 January 1920. | |
| A | US, A, 1,447,478 (KOSHOLLEK ET AL.) 06 March 1923. | |
| A | US, A, 1,633,168 (DICKERMAN) 06 June 1927. | |
| A | US, A, 1,833,645 (HARTZ) 24 November 1931. | |

Further documents are listed in the continuation of Box C. See patent family annex.

| | |
|---|--|
| * Special categories of cited documents: | "T" later document published after the international filing date or priority date and not in conflict with the application but cited to understand the principle or theory underlying the invention |
| "A" document defining the general state of the art which is not considered to be part of particular relevance | "X" document of particular relevance; the claimed invention cannot be considered novel or cannot be considered to involve an inventive step when the document is taken alone |
| "E" earlier document published on or after the international filing date | "Y" document of particular relevance; the claimed invention cannot be considered to involve an inventive step when the document is combined with one or more other such documents, such combination being obvious to a person skilled in the art |
| "L" document which may throw doubts on priority claim(s) or which is cited to establish the publication date of another citation or other special reason (as specified) | "Z" document member of the same patent family |
| "O" document referring to an oral disclosure, use, exhibition or other means | |
| "P" document published prior to the international filing date but later than the priority date claimed | |

| | |
|--|--|
| Date of the actual completion of the international search 26 OCTOBER 1992 | Date of mailing of the international search report 21 DEC 1992 |
|--|--|

| | |
|---|--|
| Name and mailing address of the ISA/US Commissioner of Patents and Trademarks Box PCT Washington, D.C. 20231 Facsimile No. NOT APPLICABLE | Authorized officer <i>Nguyen Ngoc Ho</i> HAROLD TUDOR NGUYEN NGOC-HO INTERNATIONAL DIVISION Telephone No. (703) 308-0497 |
|---|--|

INTERNATIONAL SEARCH REPORT

International application No.
PCT/US92/08055

C (Continuation). DOCUMENTS CONSIDERED TO BE RELEVANT

| Category* | Citation of document, with indication, where appropriate, of the relevant passages | Relevant to claim No. |
|-----------|--|-----------------------|
| A | US, A, 2,327,950 (WHIPPLE) 24 August 1943. | |
| A | US, A, 2,765,738 (FRECH, JR.) 09 October 1956. | |
| A | US, A, 2,838,000 (SCHREIBER) 10 June 1958. | |
| A | US, A, 3,003,420 (NOSLER) 10 October 1961. | |
| A | US, A, 4,044,685 (AVCIN) 30 August 1977. | |
| A | US, A, 4,136,616 (SCHIRNEKER) 30 January 1979. | |
| A | US, A, 4,625,650 (BILSBURY) 02 December 1986. | |
| A | US, A, 4,655,140 (SCHIRNEKER) 07 April 1987. | |
| A | US, A, 4,685,397 (SCHIRNEKER) 11 August 1987. | |
| A | US, A, 4,753,172 (KATZMANN ET AL.) 28 June 1988. | |
| A | US, A, 4,949,645 (HAYWARD ET AL.) 21 August 1990. | |
| A | GB, A, 6,785 (STANBRIDGE) 18 April 1912. | |
| A | GB, 27,342 (HOOKHAM) 19 September 1907. | |