



(12) **EUROPEAN PATENT APPLICATION**

(43) Date of publication:  
**15.04.2009 Bulletin 2009/16**

(51) Int Cl.:  
**A44B 19/42 (2006.01)**

(21) Application number: **08172855.2**

(22) Date of filing: **22.03.2005**

(84) Designated Contracting States:  
**DE FR GB IT PL**

(72) Inventor: **Leighton, Murray Edward Bruce**  
**Harrogate, North Yorkshire HG1 3EH (GB)**

(30) Priority: **24.03.2004 GB 0406626**

(74) Representative: **W.P. Thompson & Co.**  
**Eastcheap House**  
**Central Approach**  
**Letchworth Garden City,**  
**Hertfordshire SG6 3DS (GB)**

(62) Document number(s) of the earlier application(s) in accordance with Art. 76 EPC:  
**05729432.4 / 1 737 311**

(71) Applicant: **Illinois Tool Works, Inc.**  
**Glenview, Illinois 60026 (US)**

Remarks:

This application was filed on 23-12-2008 as a divisional application to the application mentioned under INID code 62.

(54) **Application of zipper lengths to a web**

(57) The apparatus comprises a rotary turret 18 having circumferentially spaced grooves 30a, 30b, 30c for receiving pre-cut lengths of zipper 58 consisting of first and second interengageable profile strips. Sliders 46 for engaging and re-engaging the profiles are mounted on the zipper lengths by a rotary slider applicator 42. A web

12 of plastics material is fed beneath the turret 18 and receives the zipper lengths which are secured to the web by a heated sealing bar 60. The web with zippers attached is fed to a form-fill-seal machine 20 on which the web is formed into individual bags which are filled and separated from one another.

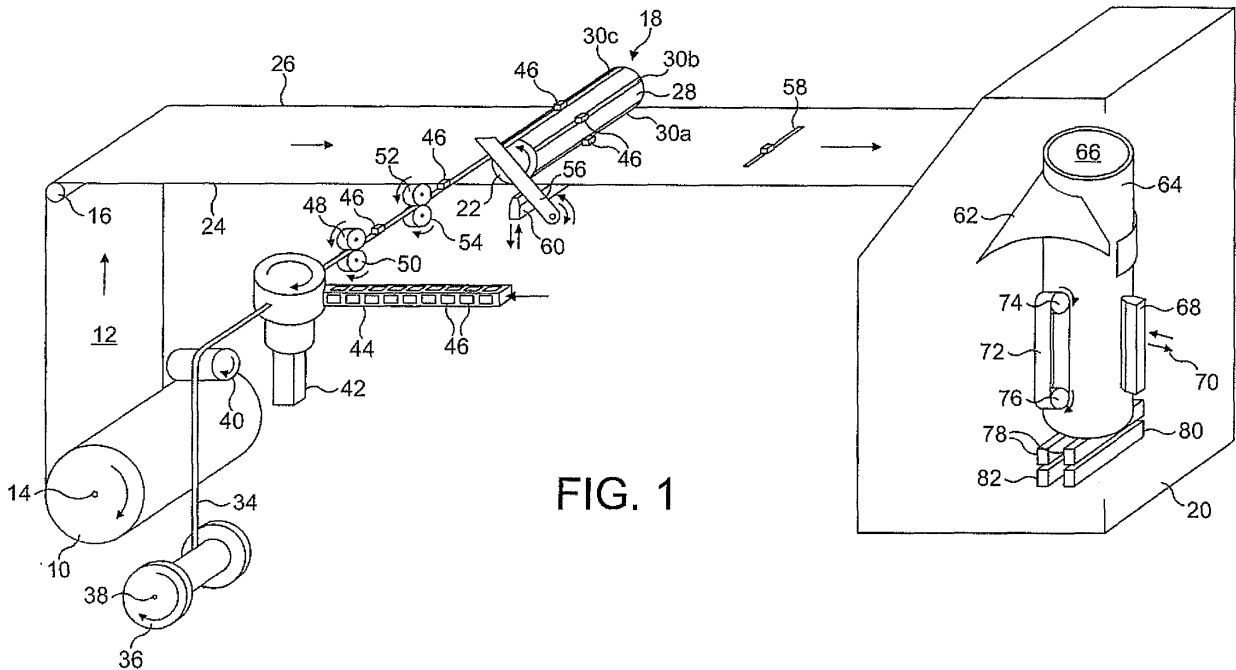

**FIG. 1**

## Description

**[0001]** The present invention relates to reclosable fasteners of the type known as "zippers". These consist of first and second lengths of material, usually plastics, which are shaped to engage with each other along their lengths. The individual lengths of material are known as "profiles". When provided with a slider which is mounted on the profiles and is movable therealong to engage and disengage the profiles, the zipper is known as a "slider zipper".

**[0002]** The present invention is concerned with the application of lengths of slider zipper to a web of material in a manner known as "cross-web technology". This means that individual lengths of zipper are applied to the web to extend transversely, usually perpendicularly, to the longitudinal dimension of the web and spaced at longitudinal intervals.

**[0003]** The present invention provides an apparatus for applying pre-cut lengths of zipper transversely to a moving web of material at intervals spaced in the direction of movement of the web, comprising:

means for advancing a web of material in a predetermined direction;

a turret having a surface containing a plurality of circumferentially-spaced axially-extending grooves for receiving pre-cut lengths of zipper;

means for driving the turret to rotate about the axis of the cylinder;

the turret being positioned relative to the web so that its axis of rotation extends transversely to the direction of advancement of the web and, upon rotation of the turret, the grooves in its surface are brought successively to a location in which pre-cut zipper lengths occupying the grooves are presented for attachment to the web;

means for feeding pre-cut lengths of zipper comprising first and second interengageable profiles and a slider mounted thereon successively to the grooves of the turret at a loading location different from the attachment location;

means for causing removal of pre-cut zipper lengths from the grooves of the turret at the attachment location and for attachment of the zipper lengths to the web; and

means for mounting sliders on the zipper so each length of zipper fed to the turret has a slider mounted thereon.

**[0004]** Preferably, the means for mounting the sliders on the zipper comprise a rotary zipper applicator.

**[0005]** Conveniently, a knife is located between the slider applicator and the feeding location for cutting a continuous supply of zipper into the pre-cut lengths.

**[0006]** Advantageously, each groove in the turret includes a wider portion for receiving the slider on each pre-cut zipper length, each wider portion preferably ex-

tending to slightly beyond the mid-point of the groove from an insertion end thereof.

**[0007]** Conveniently, the means for removal and attachment of the zipper lengths comprises a heated sealing bar which is movable towards and away from the film and is located adjacent the attachment location at the opposite side of the film to the turret.

**[0008]** In an apparatus according to the invention in which the slider-mounting means produces zipper having its profiles disengaged from each other, the apparatus preferably includes, between the slider-mounting means and the turret, a device for engaging the zipper profiles with each other, the device comprising a pair of rollers through the nip of which the zipper passes and which are arranged to engage the profiles of the zipper with each other and to separate from each other to allow the sliders to pass therebetween.

**[0009]** Preferably, the roller surfaces forming the nip are convex.

**[0010]** Preferably the apparatus includes a form-fill-seal machine arranged to receive the web with zippers attached and to form the web into bags and to fill the bags with a product, the zipper lengths forming reclosable fasteners of the bags.

**[0011]** Alternatively, the apparatus includes a machine arranged to receive the web with zippers attached and to form the web into bags for subsequent filling with a product, the zipper lengths forming reclosable fasteners of the bags.

**[0012]** Another option is to include a means for forming the web with zippers attached into a roll for subsequent use in making empty bags or in a form-fill-seal machine.

**[0013]** In another aspect, the invention provides a device for engaging the profiles of a slider zipper, the device comprising a pair of rollers through the nip of which the zipper passes and which are arranged to engage the profiles of the zipper with each other and to separate from each other to allow the sliders to pass therebetween.

**[0014]** Preferably, the roller surfaces forming the nip are convex.

**[0015]** The invention also provides a method of applying pre-cut lengths of zipper transversely to a moving web of material at intervals spaced in the direction of movement of the web, comprising

providing a web of material;

advancing the web in a predetermined direction past a rotary turret positioned to rotate about an axis transverse to the predetermined direction and having a surface containing a plurality of circumferentially-spaced axially-extending grooves for receiving pre-cut lengths of zipper;

the turret being positioned relative to the web so that, upon rotation, the zipper-receiving grooves thereof are brought successively to a zipper-application location in which zipper lengths occupying the grooves are presented for application to the web in directions extending transversely thereof;

feeding pre-cut lengths of zipper to successive zipper-receiving grooves of the rotary turret at a location different from the zipper-application location, each zipper length comprising first and second interengageable profiles and a slider mounted thereon; rotating the turret to advance the zipper lengths successively from the receiving location to the application location; and attaching the zipper length to the web at the zipper-application location.

Conveniently, the zipper lengths are attached to the web by means of a heated sealing bar which is movable towards and away from the film and is located adjacent the attachment location at the opposite side of the film to the turret.

**[0016]** Preferably, the sliders are mounted on the zipper lengths by means of a rotary zipper applicator.

**[0017]** Conveniently, the sliders are mounted on a continuous length zipper which is subsequently cut into lengths.

**[0018]** In a method according to the invention in which the zipper profiles are disengaged during mounting of the sliders thereon and are re-engaged prior to feeding to the turret, re-engagement is preferably by passing the zipper between the nip of a pair of rollers which are arranged to separate from each other to allow the sliders to pass therebetween.

**[0019]** Preferably the method includes the further step of feeding the web with zippers attached to a form-fill-seal machine arranged to receive the web with zippers attached and to form the web into bags and to fill the bags with a product the zipper lengths forming reclosable fasteners of the bags.

**[0020]** Alternatively, the method includes the further step of feeding the web with zippers attached to a machine for forming the web into bags for subsequent filling with a product, the zipper lengths forming reclosable fasteners of the bags.

**[0021]** Another option is to include the further step of forming the web with zippers attached into a roll for subsequent use in making empty bags or in a form-fill-seal machine.

**[0022]** The invention will now be described further by way of example, with reference to the drawings of this specification, in which:

Figure 1 shows schematically an apparatus for attaching pre-cut lengths of zipper to a moving web using a rotary turret and for using the web to form bags on a vertical form-fill-seal machine;

Figure 2 shows schematically a horizontal form-fill-seal machine which can replace the vertical form-fill-seal machine shown in figure 1; and

Figure 3 shows a detail of part of the apparatus of figure 1.

**[0023]** Referring first to figure 1 of the drawings, this

shows a supply roll 10 of a plastics film material 12, for example polyethylene, which is suitable for use in making plastic bags. The roll 10 is mounted for rotation about a horizontal axis 14. From the roll 10 the film passes vertically upwards to a diverting roller 16, by which the advancing film is directed to move in a horizontal direction. The film now passes beneath a rotary turret 18 and then to a vertically-operating form-fill-seal machine which is shown generally by the reference numeral 20.

**[0024]** The rotary turret 18 is driven to rotate in a counterclockwise direction by drive means (not shown) about a horizontal axis 22 which is parallel to the plane of the film material and spaced vertically therefrom. The axis 22 extends perpendicularly to the longitudinal edges 24, 26 of the film 12.

**[0025]** The rotary turret 18 has a cylindrical surface 28 which has in it four equally-spaced axially extending grooves, of which only three 30a, 30b, 30c are visible in figure 1. The grooves are dimensioned each to receive a pre-cut length of zipper with a slider attached at its midpoint. The length of each piece of zipper is just less than one-half of the width of the film material 12. Each groove is enlarged in width from its end which is the left-hand end as shown in figure 1 to a point just beyond the midpoint of the groove. This allows each groove 30a, 30b, 30c to receive a pre-cut length of zipper with a centrally-mounted slider by insertion from the left-hand end in figure 1.

**[0026]** A supply of zipper 34 with its profiles engaged is stored in a continuous length on a spool 36 which is mounted for rotation about a horizontal axis 38. From the spool 36, the zipper passes vertically upwards to a diverting roller 40, which changes the direction of movement of the zipper into a horizontal direction. The horizontally directed zipper now passes through a rotary slider applicator 42, into which a magazine 44 charged with sliders 46 is fed in a horizontal direction substantially perpendicular to the direction of movement of the zipper 34 through the slider applicator 42.

**[0027]** The slider applicator 42 is of a type which is known per se and is obtainable from Supreme Plastics Limited of Supreme House, 300 Regents Park Road, London N3 2TL, UK. The applicator 42 is arranged to mount sliders 46 from the magazine 44 at predetermined intervals along the length of the zipper 34. During this operation, the profiles of the zipper are separated from each other.

**[0028]** After passing through the slider applicator 42, the zipper 34 passes through the nip of a first pair of rollers 48, 50 and are arranged to bring the zipper profiles into engagement with each other except where the sliders 46 are located. The rollers 48, 50 are mounted to allow for relative separating movement of the rollers to take place when a slider 46 mounted on the zipper passes through the nip of the rollers. The rollers 48, 50 are thus arranged to ride over the sliders 46 as they pass through the nip of the rollers. As can be seen in figure 3 of the drawings, the surfaces of the rollers 48, 50 defining the

nip are convex.

**[0029]** The zipper 34 now passes through the nip of a second pair of rollers 52, 54 which are driven in opposite directions by drive means (not shown) to draw the zipper from the storage spool 32, through the applicator 42 and the first pair of rollers 48, 50 and on towards the rotary turret 18.

**[0030]** A cutting knife 56 is located between the rollers 52, 54 and the rotary turret 18. The knife 56 is positioned to cut the zipper 34 into predetermined lengths 58, such that each length has a slider 46 mounted centrally and is of a length equal to slightly less than one half the width of the film 12 between its longitudinal edges 24, 26.

**[0031]** A heated sealing bar 60 is located beneath the film 12 and aligned with the grooves 30a, 30b, 30c of the turret when these are located at the "6-o'clock" position. The sealing bar 60 is movable in a vertical direction towards and away from the film 12 by control means (not shown).

**[0032]** The application of the pre-cut lengths of zipper to the film 12 by means of the rotary turret 18 will now be described. The pre-cut lengths 58 of zipper are cut and fed as described above to the turret 18 to be received in a first one 30a of its grooves when that groove is uppermost (ie in the "12-o'clock" position). The rotation of the turret is stopped by suitable control of its drive means whilst feeding of the zipper takes place. The zipper length 58 with its respective slider 46 mounted thereon is located centrally in the groove 30a. The turret is now driven to rotate counterclockwise through 90° (ie until the groove 30a is located at the "9-o'clock" position) and stopped to allow a further zipper length inserted in the groove 30b which is now to be found at the "12-o'clock" position. Further movement of the turret counterclockwise through another 90° brings the groove 30a to the "6-o'clock" position at which the turret 18 is again stopped. The web is also stopped.

**[0033]** The sealing bar 60 is now arranged to move upwards to contact the film 12 beneath the groove 30a when in the "6-o'clock" position. This action of the sealing bar removes the zipper length 58 from the groove 30a and causes it to be heat-sealed to the film 12 so that it extends transversely of the film 12 mid-way between and perpendicular to its longitudinal edges 24, 26. The slider 46 is thus located centrally of the film 12.

**[0034]** Further rotation of the turret 18 through another 90° now takes place, bringing the next groove 30b and the zipper length 58 therein to the "6-o'clock" position and the zipper length thus ready to be applied to the film 12. The film is stopped in this position and the sealing bar 60 moves to attach the zipper to the film as described above.

**[0035]** Simultaneously with each zipper length being applied to the film at the "6-o'clock" position, a further zipper length is introduced at the "12-o'clock" position, so that a zipper length is applied to the film at spaced intervals corresponding to the longitudinal distance which the film moves during the time in which the turret

18 rotates through 90°.

**[0036]** The operation of the drive means for the film 12, the rotary applicator 42, the drive rollers 48, 50, the cutting knife 52, the drive rollers for the turret 18 and the sealing bar 60 are co-ordinated by control means (not shown) so that steps described above can be carried out continuously.

**[0037]** The form-fill-seal machine 20 operates in a known manner and comprises a forming collar 62, over which the film 12 passes. The collar 62 is shaped to form the film into a tubular shape around the outer surface of a filling cylinder 64, into the hollow centre 66 of which product to be filled into bags formed by the machine 20 can be fed. The path of the film through the machine 20 is suitably relieved to allow for passage of the sliders 46. Upon being formed into a tubular shape around the cylinder 64, the longitudinal edges 24, 26 of the film are overlapped so that they can be sealed together by a heated sealing bar 68 which is movable back-and-forth in the directions of the arrows 70 in the figure.

**[0038]** A drive belt 72 operating over rollers 74, 76 contacts the film 12 as it passes down the outside of the cylinder 64. A further pair of rollers and a drive belt are located at the opposite side of the cylinder 64 and, together with the belt 72 and rollers 74, 76, apply a traction which draws the film through the apparatus described above from the supply roll 10.

**[0039]** Beneath the filling cylinder 64 are positioned in known manner a pair of heated sealing bars 78 which incorporate a cutting knife (not shown). The heated bars 78 and the knife are arranged simultaneously to form a transverse top seal on each bag formed after it has been filled, to sever that bag from the next bag and to form a transverse bottom seal on the next bag. Filled bags heat sealed top and bottom are thereby produced.

**[0040]** Beneath the sealing bars 78, a heated zipper-sealing bar 80 is mounted and arranged for movement towards and away from a fixed bar 82. The heated bar 80 moves towards the fixed bar to clamp the film and zipper strip 58 therebetween and thus attach the unattached zipper profile to the opposite wall of the bag. A reclosable slider zipper seal inside the bag below its top seal is thereby formed.

**[0041]** Figure 2 of the drawings shows a modification of the apparatus shown in figure 1, in which the vertical form-fill-seal machine 20 is replaced by a horizontal form-fill-seal machine which operates in a known manner in which the film 12 with slider zippers 58 mounted thereon is formed in a forming box 84 around product located on a drive belt (not shown) and then sealed and severed into individual bags by a back sealer 86 and rotary sealing and cutting bars 88. A reclosable slider zipper seal is also formed inside the bag by a heated zipper-sealing bar.

**[0042]** In further modifications, the form-fill-seal machines are replaced by respective bag-making machines to produce empty bags which can be filled and sealed subsequently. Such bags are known as "pre-made bags".

**[0043]** In another modification, the form-fill-seal ma-

chine 20 is omitted and the film 12 simply re-wound onto a reel for subsequent use either in a vertical or horizontal form-fill-seal machine or in a bag-making machine as mentioned above. This process is of the type known as a "reel-to-reel" process.

**[0044]** The following clauses define aspects of the disclosure of this application:

1. An apparatus for applying pre-cut lengths of zipper transversely to a moving web of material at intervals spaced in the direction of movement of the web, comprising:

means for advancing a web of material in a pre-determined direction;

a turret having a surface containing a plurality of circumferentially-spaced axially-extending grooves for receiving pre-cut lengths of zipper; means for driving the turret to rotate about the axis of the cylinder;

the turret being positioned relative to the web so that its axis of rotation extends transversely to the direction of advancement of the web and, upon rotation of the turret, the grooves in its surface are brought successively to a location in which pre-cut zipper lengths occupying the grooves are presented for attachment to the web;

means for feeding pre-cut lengths of zipper comprising first and second interengageable profiles and a slider mounted thereon successively to the grooves of the turret at a loading location different from the attachment location;

means for causing removal of pre-cut zipper lengths from the grooves of the turret at the attachment location and for attachment of the zipper lengths to the web; and

means for mounting sliders on the zipper so each length of zipper fed to the turret has a slider mounted thereon.

2. An apparatus according to clause 1, to which the means for mounting the sliders on the zipper comprise a rotary zipper applicator.

3. An apparatus according to clause 2, in which a knife is located between the slider applicator and the feeding location for cutting a continuous supply of zipper into the pre-cut lengths.

4. An apparatus according to any preceding clause, in which each groove in the turret includes a wider portion for receiving the slider on each pre-cut zipper length.

5. An apparatus according to clause 4, in which each wider portion extends to slightly beyond the midpoint of its respective groove from an insertion end

thereof.

6. An apparatus according to any preceding clause, in which the means for removal and attachment of the zipper lengths comprises a heated sealing bar which is movable towards and away from the film and is located adjacent the attachment location at the opposite side of the film to the turret.

7. An apparatus according to any preceding clause, in which the slider-mounting means produces zipper having its profiles disengaged from each other and the apparatus includes, between the slider-mounting means and the turret, a device for engaging the zipper profiles with each other, the device comprising a pair of rollers through the nip of which the zipper passes and which are arranged to engage the profiles of the zipper with each other and to separate from each other to allow the sliders to pass therebetween.

8. An apparatus according to clause 7, in which the roller surfaces forming the nip are convex.

9. An apparatus according to any preceding clause, including a form-fill-seal machine arranged to receive the web with zippers attached and to form the web into bags and to fill the bags with a product, the zipper lengths forming reclosable fasteners of the bags.

10. An apparatus according to any of clauses 1 to 8, including a machine arranged to receive the web with zippers attached and to form the web into bags for subsequent filling with a product, the zipper lengths forming reclosable fasteners of the bags.

11. An apparatus according to any of clauses 1 to 8, including a means for forming the web with zippers attached into a roll for subsequent use in making empty bags or in a form-fill-seal machine.

12. A device for engaging the profiles of a slider zipper, the device a pair of rollers through the nip of which the zipper passes and which are arranged to engage the profiles of the zipper with each other and to separate from each other to allow the sliders to pass therebetween.

13. A device according to clause 12, in which the roller surfaces forming the nip are convex.

14. A method of applying pre-cut lengths of zipper transversely to a moving web of material at intervals spaced in the direction of movement of the web, comprising

providing a web of material;

advancing the web in a predetermined direction past a rotary turret positioned to rotate about an axis transverse to the predetermined direction and having a surface containing a plurality of circumferentially-spaced axially-extending grooves for receiving pre-cut lengths of zipper; the turret being positioned relative to the web so that, upon rotation, the zipper-receiving grooves thereof are brought successively to a zipper-application location in which zipper lengths occupying the grooves are presented for application to the web in directions extending transversely thereof; feeding pre-cut lengths of zipper to successive zipper-receiving grooves of the rotary turret at a location different from the zipper-application location, each zipper length comprising first and second interengageable profiles and a slider mounted thereon; rotating the turret to advance the zipper lengths successively from the receiving location to the application location; and attaching the zipper length to the web at the zipper-application location.

15. A method according to clause 14, in which the zipper lengths are attached to the web by means of a heated sealing bar which is movable towards and away from the film and is located adjacent the attachment location at the opposite side of the film to the turret.

16. A method according to clause 14 or 15, in which the sliders are mounted on the zipper lengths by means of a rotary zipper applicator.

17. A method according to any of clauses 14 to 16, in which the sliders are mounted on a continuous length of zipper which is subsequently cut into lengths.

18. A method according to any of clauses 14 to 17, in which the zipper profiles are disengaged during mounting of the sliders thereon and are re-engaged prior to feeding to the turret, re-engagement being by passing the zipper between the nip of a pair of rollers which are arranged to separate from each other to allow the sliders to pass therebetween.

19. A method according to any of clauses 14 to 18, including the further step of feeding the web with zippers attached to a form-fill-seal machine arranged to receive the web with zippers attached and to form the web into bags and to fill the bags with a product the zipper lengths forming reclosable fasteners of the bags.

20. A method according to any of clauses 14 to 18,

including the further step of feeding the web with zippers attached to a machine for forming the web into bags for subsequent fitting with a product, the zipper lengths forming reclosable fasteners of the bags.

21. A method according to any of clauses 14 to 18, including the further step of forming the web with zippers attached into a roll for subsequent use in making empty bags or in a form-fill-seal machine.

22. An apparatus for applying pre-cut zipper lengths to a web, the apparatus being substantially as hereinbefore described with reference to the drawing.

23. A method of applying pre-cut zippers lengths to a web, the method being substantially as hereinbefore described with reference to the drawing.

### Claims

1. A device for engaging the profiles of a slider zipper, the device comprising a pair of rollers through the nip of which the zipper passes and which are arranged to engage the profiles of the zipper with each other and to separate from each other to allow the sliders to pass therebetween.
2. A device according to claim 1, in which the roller surfaces forming the nip are convex.

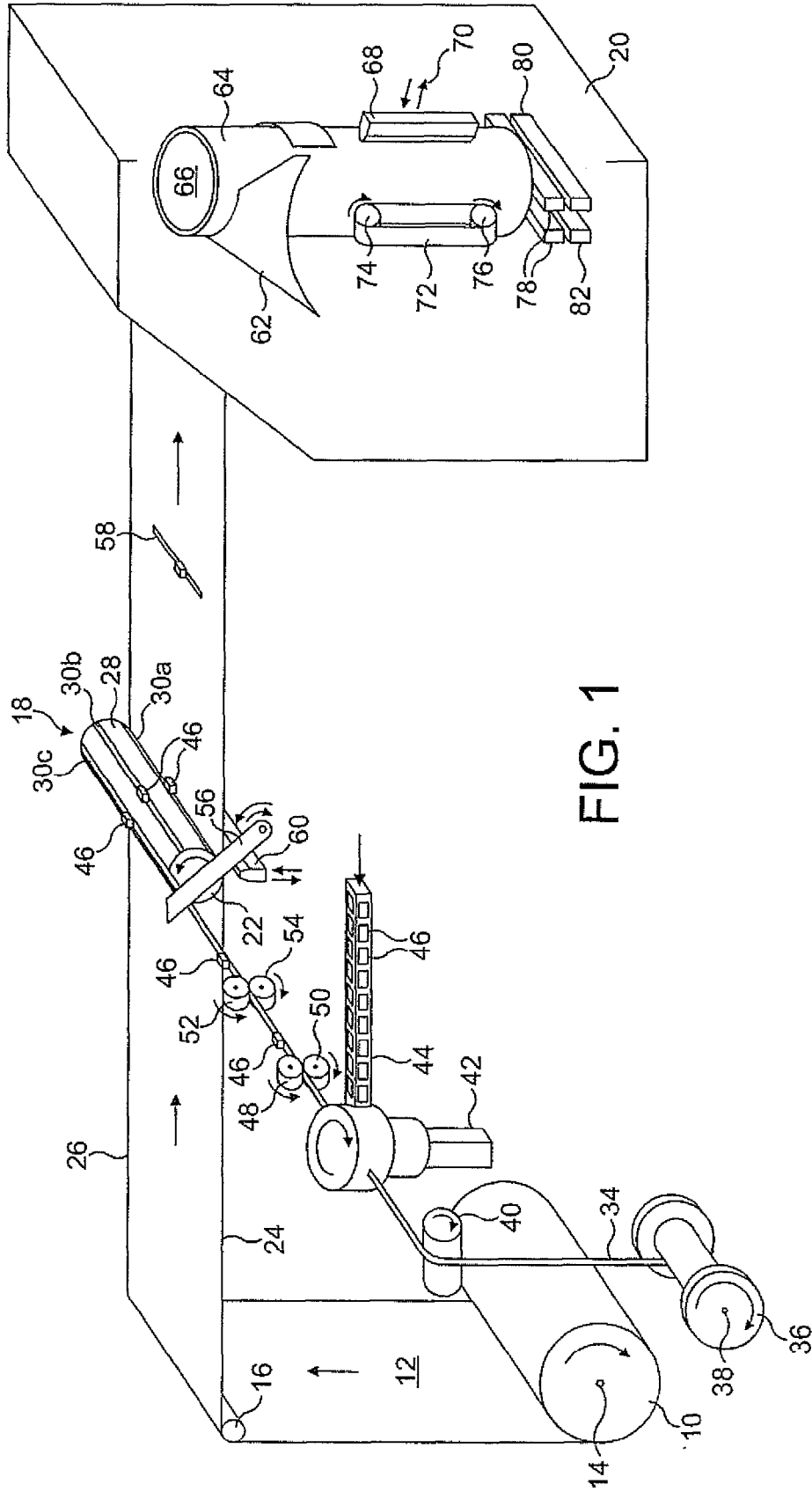

FIG. 1

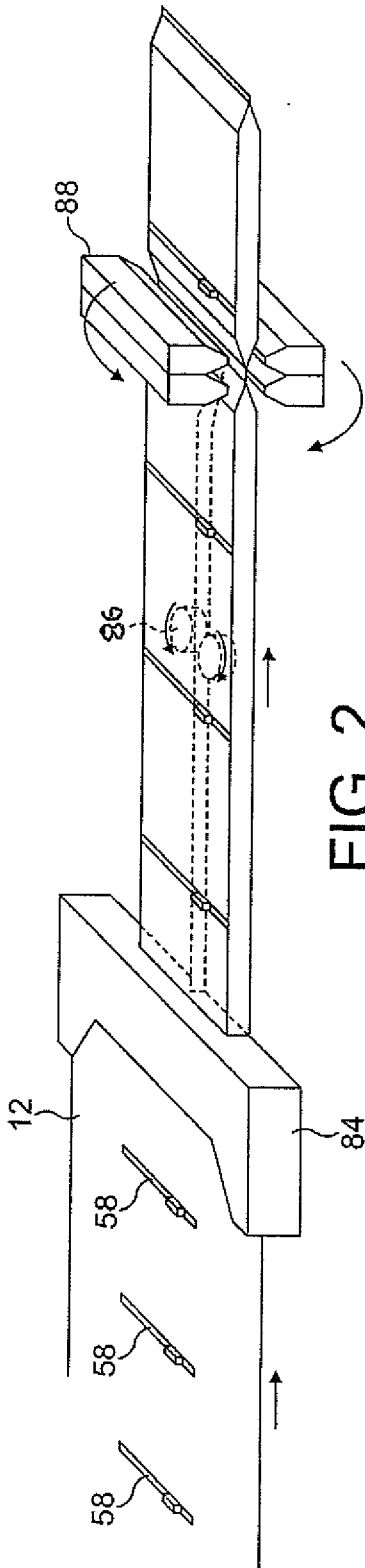

FIG. 2

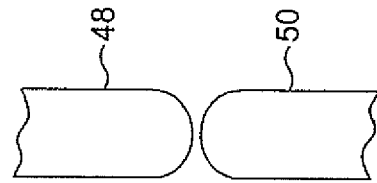

FIG. 3