

Oct. 30, 1934.

D. D. TAYLOR

1,979,179

METAL SPRAYING APPARATUS

Filed April 29, 1933

2 Sheets-Sheet 1

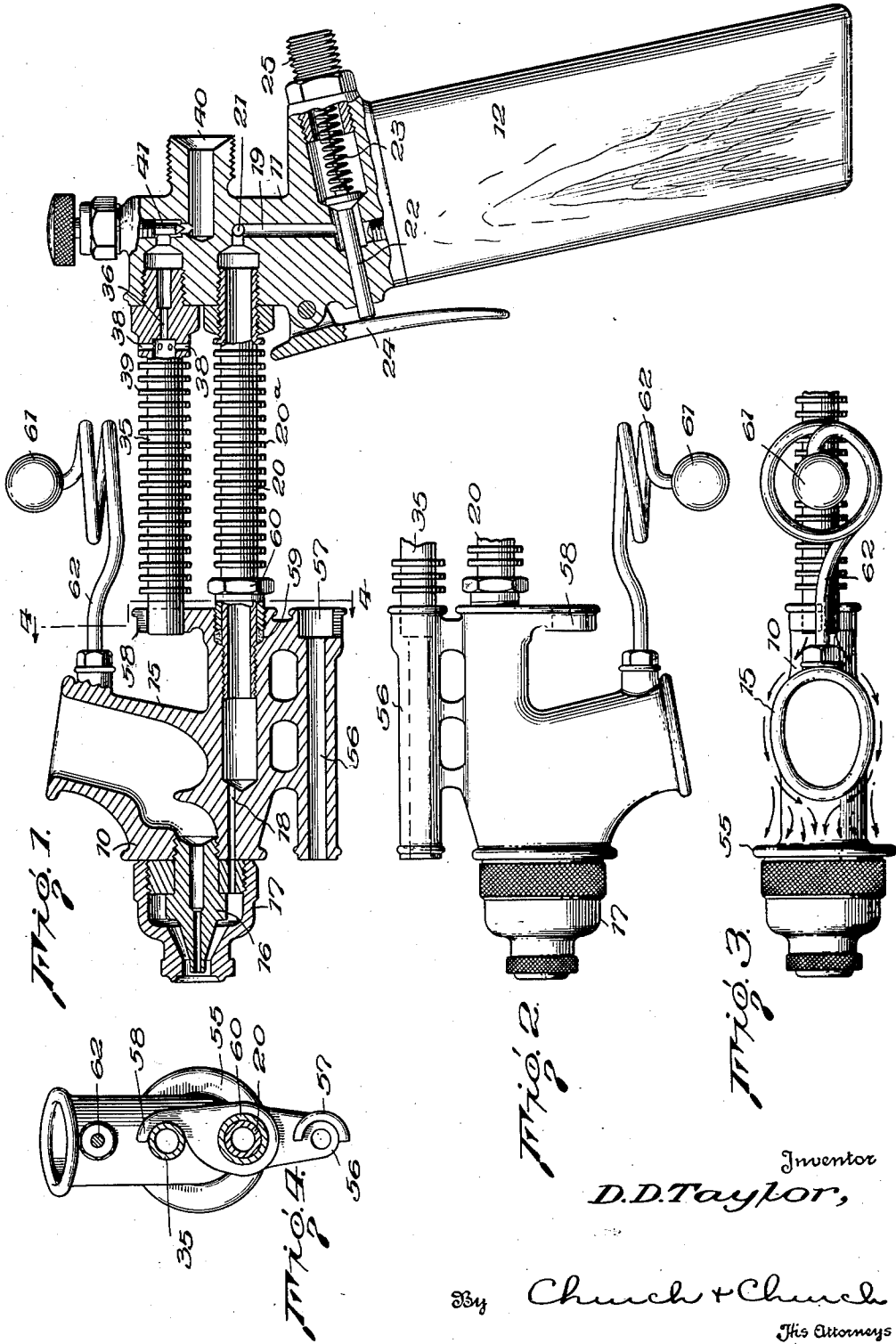

Inventor
D.D. Taylor,

By *Church & Church*
His Attorneys

Oct. 30, 1934.

D. D. TAYLOR

1,979,179

METAL SPRAYING APPARATUS

Filed April 29, 1933

2 Sheets-Sheet 2

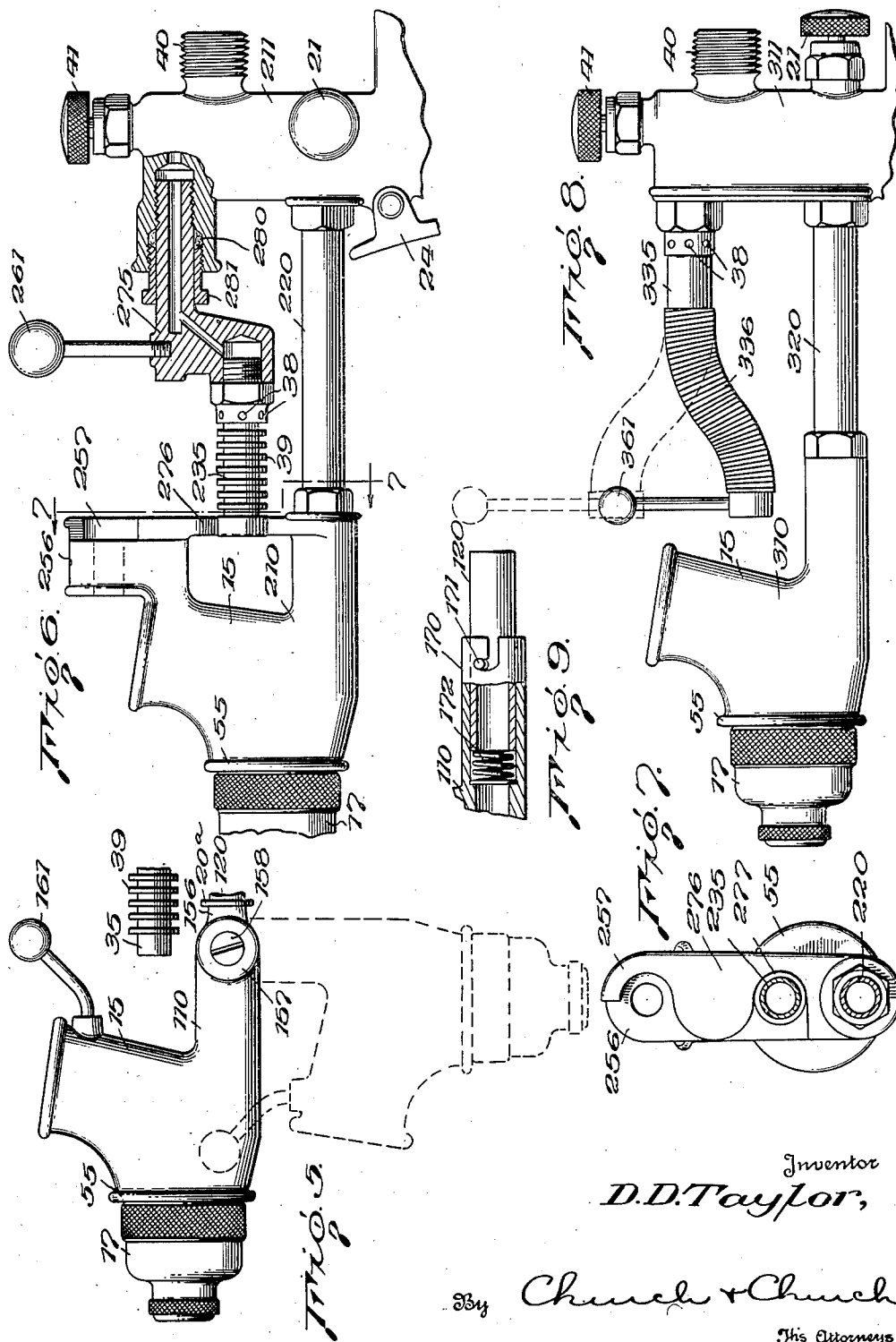

Inventor
D. D. Taylor,

By Church & Church
His Attorneys

UNITED STATES PATENT OFFICE

1,979,179

METAL SPRAYING APPARATUS

Donald D. Taylor, Duncannon, Pa., assignor to
Advance Engineering Corporation, Duncannon,
Pa., a corporation of Pennsylvania

Application April 29, 1933, Serial No. 668,653

12 Claims. (Cl. 91—12.2)

My invention relates to improvements in metal-spraying apparatus, and has to do, more particularly, with improvements in pistols for spraying such metals as lead, tin, zinc, and the like, either pure or alloyed.

It is a primary object of my invention to provide a metal-spraying device which is of simple construction and high efficiency.

It is an object of my invention to provide a metal-spraying pistol which is light in weight and can be employed for long periods without fatiguing the operator.

It is an object of my invention to provide a metal-spraying pistol in which the torch employed for melting the stock to be sprayed may at will also be employed for preheating the surface of the object to be sprayed or for heating the sprayed coating or filling after its application.

Further objects, and objects relating to details and economies of construction and operation will definitely appear from the detailed description to follow. My invention is clearly pointed out in the appended claims. Preferred embodiments of my invention are illustrated in the accompanying drawings, in which:

Figure 1 is a view, taken in side elevation, of a preferred form of metal-spraying pistol embodying the present invention, the control head being shown in section and the spraying head, with its stock-melting chamber and the preheating torch, also being shown in section;

Fig. 2 is a view, in side elevation, of the spraying head and melting chamber in inverted position with the preheating torch disposed in operative position;

Fig. 3 is a view, in top elevation, of the spraying head of the pistol, the parts being disposed in position for spraying, as shown in Fig. 1;

Fig. 4 is a vertical sectional view taken on the line 4—4 of Fig. 1;

Fig. 5 is a view, in side elevation, of the spraying head of a modified form of my invention in which the spray head and melting chamber are swingable downwardly out of the line of the heating torch to permit use of the latter in its preheating or coating-heating capacity;

Fig. 6 is a view, in side elevation, of another modified form of my invention in which the spraying head and control head are rigidly mounted in alinement, and in which the heating torch is swingable into and out of heating relation with respect to the stock-melting chamber;

Fig. 7 is a vertical sectional view taken on the line 7—7 of Fig. 6;

Fig. 8 is a view, in side elevation, of another modified form of my invention, in which the control and spraying heads are stationary with respect to each other and in which the heating torch is flexible and capable of disposition into or out of heating relation with respect to the stock-melting chamber; and

Fig. 9 is a detail view of a portion of the spraying head and air tube supporting the spraying head, showing the spring and bayonet-slot securing means by which the head may be attached or detached at will to permit use of the heating torch for its several purposes.

The same reference numerals refer to similar parts throughout the several views.

Broadly, my invention consists in the provision of a simple pistol for applying coatings and fillings of metal or equivalent substances, which may be readily converted from a spray gun to a torch for preheating objects to be sprayed or for heating coatings or fillings after their application. The preheating of objects prior to spraying is of great importance where the bond between the coating and the object to be coated is effected by use of a flux or tinning agent. Thus, with a readily convertible device of the present type, not only may the necessity of having a distinct preheating torch such as the conventional welding torch be eliminated, but considerable time may be saved by the operator. Likewise, the convertible character of the present device is of great value in connection with the heating of coatings or fillings after their application. As in the case of its use as a preheating torch, the need for a distinct heating torch is avoided and the delay incident to the employment of two pieces of apparatus is eliminated. In this connection, it should be explained that heating of sprayed metallic coatings and fillings is desirable for two primary reasons. First, sprayed metal, as a rule, is more or less crystalline in character and quite brittle, having a marked tendency toward fracture when flexed. By applying heat to sprayed metal until it has become plastic, the crystalline character thereof is changed and the resistance to fracture is greatly increased.

Another broadly novel feature of my invention consists in the streamlining of the external walls of the melting pot for metal stock permitting the use of a simple external torch.

More specifically, and with particular reference to the accompanying drawings in which I have illustrated several preferred structural forms in which my invention is embodied, there is shown in Figs. 1 to 4 a pistol of the general type shown

and claimed in my copending application, Serial No. 613,531, filed May 25, 1932 which has eventuated into Patent No. 1,934,891. Like the pistol therein disclosed, the present pistol consists, broadly, of a spraying head 10 having formed therein a melting chamber or pot 15 for bar or strip stock, and carrying threadedly mounted jets 16 and 17 for molten metal and compressed air, respectively, a control head 11, a manual grip 12, and a compressed air conducting tube 20, by which the spraying head 10 and control head 11 are held in assembly. As in the pistol construction of the said copending application, compressed air is supplied to the device by the connection, to a threaded nipple 25, of a flexible air supply hose (not shown). Likewise, air is conducted, subject to control by the trigger 24, past the trigger valve 22 with its spring 23, through the duct 19; is subjected to regulation by the needle valve 21, and thence conducted through the tube 20 and duct 18 to the jet 17 of the atomizing nozzle. A nipple 40 is formed integral with the control head 11, and to this nipple a supply of compressed acetylene, or similar inflammable gas, is fed by means of a flexible hose, (not shown). By means of a regulating valve 41, the inflammable gas is allowed to pass at a desired rate to the tubular torch 35 having air inlet ports 38 and a gas jet 36. For the purpose of dissipating heat, thereby lessening the tendency toward heating of the control head 11, a series of fins 39 are formed upon the torch tube 35. A similar series of fins 20a are also provided upon the air tube 20. With the device adjusted as shown in Fig. 1, flame projected from the torch 35 impinges upon the walls of the melting pot 15 and, due to the ovate or streamlined cross-sectional form thereof, as shown in Fig. 3, is caused to part into two branches, each of which hugs the adjacent side wall of the pot and finally tends to merge again, at the forward portion of the pot, with the other branch. Thus there is effected substantially complete encirclement of the intermediate portion of the melting pot by the tongue of flame projected from the torch 35. I am aware that similar streamlining of objects subject to air currents is well known, but I regard the herein disclosed application of this principle to effect substantially uniform and highly efficient heating of a portable melting pot by a single external torch of simple construction to be new in the art. For the purpose of preventing the projection of heat beyond the spray nozzle of the pistol, and also for the purpose of maintaining said nozzle in a warm condition conducive to fine atomization, I provide a flange 55 which obstructs and laterally deflects the blast of hot gas from the torch. The importance of this flange 55 is readily understood in a pistol adapted for repairing holes and dents in automobile bodies and the like where surfaces adjacent the injury to be repaired are highly finished as with lacquer. As is well known, the temperature of the atomized metal particles projected from a device of the present type is not great, and, if the object being repaired is protected from other sources of heat, the repair may be made without injury to even closely adjacent objects.

In each of the five disclosed embodiments of my present invention, provision is made for the quick and easy conversion of the pistol from a spraying device to a preheating or coating-tempering torch. In the pistol disclosed in Figs. 1 to 4, the construction by which this convertibility is effected consists in the blindless, untapered thread-

ing of the air tube 20 in the spraying head 10 so that the latter may be rotated 180° upon the threaded end of the tube 20, the provision of a torch extension tube 56 having a semicircular end 57 engageable with the forward end of the torch tube 35 and constituting a stop assuring proper element of the extension 56 and the torch proper 35, the provision of a similar stop 58 assuring alinement of the spraying head 10 with the torch 35 when the spraying head is rotated to operative position, and a packing ring 59 and packing nut 60 disposed in the spraying head and about the tube 20. A handle 61 having a coiled, heat-radiating shank 62 attached to the spraying head 10 makes possible easy rotation of the spraying head to the desired limit of movement permitted by the stops 57 and 58. Fig. 1 illustrates the device in position for spraying while Fig. 2 illustrates the spraying head in inverted position permitting use of the device as a simple torch.

In Fig. 5 there is illustrated a spraying head 110 and means for mounting said head to the air tube 120 so that the torch 35 may be selectively employed either for heating the melting pot 15 or for heating an object or coating without interference or obstruction by the spraying head 110. The control head (not shown) and the atomizing nozzle of this form of pistol are preferably identical with those of the pistol shown in Figs. 1 to 4 and need not be described. The melting pot 15 is of ovate shape similar to that of the pistol shown in Figs. 1 to 4. Instead of the swiveled connection shown in Fig. 1, however, the connection of the spraying head 110 to the air tube 120 has the form of a knuckle consisting of an eye portion 156 formed on the end of the air tube 120 which is snugly engaged in a jaw portion 157 formed on the spraying head 110. A screw 158 maintains said knuckle portions in assembly permitting vertical pivotal movement of the head 110 with respect to the tube 120. A compressed air duct (not shown) extends through the knuckle joint which is otherwise of the usual character employed in articulated fluid lines. A handle 161, anchored in the head 110, constitutes a facile means by which the head 110 may be swung upwardly to spraying position, or downwardly into non-spraying position permitting use of the torch 35 as a preheating or coating-heating element.

In Fig. 9, there is shown a bayonet joint means of connecting the spraying head 110 to the air tube 120. In a pistol employing such a connection, the spraying head 110 is not permanently secured to the air tube 120 as in the previously described pistols, but is readily detachable therefrom, permitting use of the torch for purposes other than heating the melting pot. More specifically, the bayonet joint comprises a bayonet slotted tubular portion 170 formed integral with the rear end of the spraying head 110, a pin 171 or pins extending outwardly from the air tube 120 and engageable with the slot or slots in the tubular portion 170, and a spring 172 disposed within the portion 170 and yieldably holding said pin associated with said slot.

The form of pistol shown in Figs. 6 and 7 is generally similar to that shown in Figs. 1 to 4, with the exception that the spraying head 210 is rigidly mounted upon the air tube 220 which, in turn, is rigidly mounted upon the control head 211. For the purpose of permitting use of the device as a heating torch unobstructed by the melting pot 15, the torch 235 is threaded into an offset mounting 275, which is journaled swively in the control head 211 by means of threads which

permit free rotation of the socket 275 for an extent of 180°. Leakage of gas past said threads is prevented by means of a packing ring 280 retained snugly in the joint by means of a packing nut 281. A torch extension 256 of lesser extent than that 56 of the pistol illustrated in Fig. 1 is formed integral with and at the top of the spraying head 210, which extension is provided with a semi-circular stop 257 which engages the torch 235 when swung upwardly with its offset mounting 275. A handle element 261 is attached to the mounting 275 for the torch and is displaced sufficiently therefrom to be maintained sufficiently cool for grasping by the operator. A web 276, integral with the spraying head 210, extends from the air tube connected portion thereof to the stop 257 and is intermediately notched at 277 to serve as a stop for determining the proper disposition of the torch 235 with respect to the ovate melting pot 15 during the spraying operation.

In Fig. 8, I have illustrated a pistol construction similar to that shown in Fig. 6, the primary distinction being that the torch 335 is rigidly mounted in the control head 311, but is inherently displaceable without the requirement of an offset swiveled mounting. In this embodiment of my invention the torch 335 is constituted in part by a section 336 of flexible metallic tubing which, when bent downwardly by the application of pressure upon the handle 361, will direct flame horizontally against the rear face of the ovate melting pot 15. When flexed upwardly, as shown in dotted lines, the tongue of flame projected by the torch will clear the spraying head 310 and may be directed against any object desired, as in the case of the other illustrated forms of my invention.

From the preceding description the operation of the devices illustrated should be easily understood. In general, metal or other coating material disposed in the melting chamber 15 is reduced to the molten state by reason of the heat imparted to the melting chamber by the gas torch. Compressed air controlled by the trigger operated valve 22 and regulated by the needle valve 21 passes to the compressed air jet 17 and draws molten coating material through the jet 16, atomizing it and projecting it from the nozzle of the pistol.

When the object to be coated requires preheating, with the form of pistol illustrated in Figs. 1 to 4, such preheating may be easily accomplished by swinging the spraying head 10 about its swivel mounting on the air tube 20 until the stop 57 engages the end of the torch 35 and the tube 56 constitutes an extension thereof, as shown in Fig. 2. Spraying may be accomplished by returning the spraying head 10 to its position shown in Fig. 1, in which position the stop 58 is engaged with the forward end of the torch 35, and the flame from the torch is divided into two branches which hug and encircle the melting pot 15, as shown by the arrows in Fig. 3.

Likewise, where it is desirable that a coating or filling, after its application, be tempered so as to lessen its crystalline character and brittleness, or where it is necessary to work the surface of coating or filling into a modified form by means of "wiping" or "padding", the device should be employed in its position shown in Fig. 2.

The operation of the pistol illustrated in Fig. 5 is substantially the same as that shown in Fig. 1, with the exception that the torch 35, having no extension, is brought into object-preheating or coating-heating position merely by swinging the

spraying head downwardly into the position shown by the dotted lines.

In the case of a pistol having a detachable spraying head and a connection such as shown in Fig. 9, operation of the device as an object-preheating or coating-heating torch is effected by partially rotating the spraying head and uncoupling the slotted portion 170 thereof from the pins 171.

With a pistol of the type disclosed in Fig. 6, conversion of the device from a spraying pistol to a heating torch and vice versa, is effected by grasping the handle 261 and swinging the torch 235 upwardly into engagement with the extension 256 or downwardly into engagement with the notch 277 of the web 276, respectively.

In the case of the pistol illustrated in Fig. 8, conversion of the device from a spraying pistol to a preheating or coating-heating torch is accomplished by bending the flexible tube 336, constituting the forward end of the torch 335, into the position shown by the dotted lines in that figure.

I am aware that my invention may be embodied in other forms than those illustrated. Moreover, the devices disclosed are not limited to employment in the spraying of metal, but may use, as coating or filling stock, any equivalent material which is normally solid but must be reduced to the molten state for spraying purposes. Likewise, while from the standpoint of maintaining desired temperatures in the melting pot, spray jets, and manual grip, the disclosed forms of pistols having distinct spraying heads and control heads are of advantage, the invention is not so restricted in scope. Similarly, although compressed air is generally intended for use as the atomizing and projecting medium for the coating or filling material, under some conditions, non-oxidizing or other special gases may be employed.

Numerous other uses and changes should appear to those skilled in the art. I, therefore, claim my invention broadly, as indicated by the appended claims.

What I claim is:

1. In a pistol for applying metal coatings and fillings, a melting chamber for metal stock to be sprayed, a jet for molten metal, a compressed air jet associated with said jet for molten metal to effect projection of metal in spray form, a grip for manually supporting said elements, a valve for controlling the passage of compressed air to said air jet, and a gas heating torch carried by said grip and normally disposed to direct heat upon the walls of said chamber, said torch being selectively movable out of heating relation with respect to the walls of said chamber into a position in which said torch may be employed as a means for preheating the object to be sprayed or as a means for heating previously applied coatings or fillings.

2. In a pistol for applying metal coatings and fillings, a spraying head having a melting chamber for metal stock to be sprayed and an atomizing nozzle consisting of associated compressed air and metal-spraying jets, a control head having a manual grip and a valve for controlling the passage of compressed air to said nozzle, and a gas torch carried by said control head and selectively movable with respect to said spraying head either into heating relation with the walls of said melting chamber or into displaced relation with said melting chamber permissive of use as a means for preheating objects to be sprayed or as a means for heating coatings or fillings after their application.

3. In a pistol for applying metal coatings and fillings, a spraying head having a melting chamber for metal stock to be sprayed and an atomizing nozzle consisting of associated compressed air and metal-spraying jets, a control head having a manual grip and a forwardly directed gas torch, and means for supporting said spraying head from said control head, said means including a pivotal joint upon which said spraying head may be selectively swung into spraying position in which flame projected from said gas torch plays upon and heats said melting chamber, or into non-spraying position in which said spraying head is remote from said torch permitting use of the latter as a means for preheating objects to be sprayed or as a means for heating coatings or fillings after their application.

4. In a pistol for applying metal coatings and fillings, a spraying head having a melting chamber for metal stock to be sprayed and an atomizing nozzle consisting of associated compressed air and metal-spraying jets, a control head having a manual grip, a valve for controlling the passage of compressed air to said nozzle and a forwardly directed gas torch, and means for supporting said spraying head from said control head, said means including a duct for compressed air and a pivotal joint upon which said spraying head may be selectively swung up into operative position in which flame projected from said gas torch plays upon and heats said melting chamber, or down into inoperative position in which said spraying head is remote from said torch permitting use of the latter as a means for preheating objects to be sprayed or as a means for heating coatings or fillings after their application.

5. In a pistol for applying metal coatings and fillings, a spraying head having a melting chamber for metal stock to be sprayed and an atomizing nozzle consisting of associated compressed air and metal-spraying jets, a control head having a manual grip, a valve for controlling the passage of compressed air to said nozzle and a forwardly directed gas torch, and means for supporting said spraying head from said control head, said means consisting of a tubular member anchored at its rear end in said control head and at its forward end in said spraying head, said tubular member constituting a duct for transmitting compressed air from said control head to said spraying head and having swiveled connection in one of said heads so that said spraying head may be selectively rotated with respect to said control head into an operative position in which flame projected from said gas torch plays upon and heats said melting chamber, or into inoperative position in which said melting chamber is remote from said torch permitting use of the latter as a means for preheating objects to be sprayed or as a means for heating coatings or fillings after their application.

6. In a pistol for applying metal coatings and fillings, a spraying head having a melting chamber for metal stock to be sprayed and an atomizing nozzle consisting of associated compressed air and metal-spraying jets, a control head having a manual grip, a valve for controlling the passage of compressed air to said nozzle and a forwardly directed gas torch, an extension for said gas torch mounted on said spraying head, and means for supporting said spraying head from said control head, said means consisting of a tubular member anchored at its rear end in said control head and at its forward end in said spraying head, said tubular member con-

stituting a duct for transmitting compressed air from said control head to said spraying head and having swiveled connection in one of said heads so that said spraying head may be selectively rotated with respect to said control head into spraying position in which flame projected from said gas torch plays upon and heats said melting chamber, or into non-spraying position in which said melting chamber is remote from said torch and said torch extension is associated with said torch proper to permit use of said extended torch as a means for preheating objects to be sprayed or as a means for heating coatings or fillings after their application.

7. In a pistol for applying metal coatings and fillings, a spraying head having a melting chamber for metal stock to be sprayed and an atomizing nozzle consisting of associated compressed air and metal-spraying jets, a control head having a manual grip, a valve for controlling the passage of compressed air to said nozzle, and a forwardly directed gas torch, an extension for said gas torch mounted on said spraying head, a handle of non-heating character mounted upon said spraying head and means for supporting said spraying head from said control head, said means consisting of a tubular member anchored at its rear end in said control head and at its forward end in said spraying head, said tubular member constituting a duct for transmitting compressed air from said control head to said spraying head and having a swiveled connection in one of said heads so that said spraying head may, by means of said handle, be selectively rotated with respect to said control head into spraying position in which flame projected from said gas torch plays upon and heats said melting chamber, or into non-spraying position in which said melting chamber is remote from said torch and said torch extension is associated with said torch proper to permit use of said extended torch as a means for preheating objects to be sprayed or as a means for heating coatings or fillings after their application.

8. In a pistol for applying metal coatings and fillings, a spraying head having a melting chamber for melting stock to be sprayed and an atomizing nozzle consisting of associated compressed air and metal-spraying jets, a control head having a manual grip and a valve for controlling the passage of compressed air to said nozzle, means for supporting said spraying head from said control head, and a gas torch carried by said control head and journaled for movement thereon so as to be selectively capable of disposition in heating relation with said chamber or out of heating relation with said spraying head and into unobstructed heating relation with an object to be preheated or a previously applied coating or filling.

9. In a pistol for applying coatings and fillings, a melting chamber for stock to be sprayed, and an atomizing nozzle consisting of associated compressed air and stock-spraying jets, a manual grip for supporting said chamber and nozzle, and a gas torch carried by said grip and having its jet selectively movable into heating relation with said melting chamber or out of heating relation with said chamber and into an unobstructed relation with respect to portions of said pistol permissive of use as a means for preheating objects to be sprayed or as a means for heating coatings or fillings after their application.

10. In a pistol for applying metal coatings and fillings, a spraying head having a melting cham-

ber for metal stock to be sprayed and an atomizing nozzle consisting of associated compressed air and metal-spraying jets, a control head having a manual grip and a valve for controlling the passage of compressed air to said nozzle, means for supporting said spraying head from said control head and transmitting compressed air to said spraying head, said means consisting of a tubular member anchored at one end in said control head and at the other end in said spraying head, and a gas torch swivel-mounted upon said control head and selectively rotatable with respect thereto into a position in which flame projected therefrom will be directed against the walls of said melting chamber, or into another position in which said torch is remote from said melting chamber permitting use of said torch as a means for preheating objects to be sprayed or as a means for heating coatings or fillings after their application.

11. In a pistol for applying metal coatings and fillings, a manual grip, a spraying head carried by said grip having an atomizing nozzle consisting of associated compressed air and metal-spraying jets and an open-top stock-melting pot of approximately one inch diameter and in which the end of conventional bar or strip stock may be vertically disposed and fed, and a gas torch carried by said grip and disposed with its mouth facing said melting pot for directing a horizontal tongue of flame against said intermediate portion, said melting pot being ovate in horizontal

cross-section with its long horizontal axis disposed in the line of flame so that flame impinging upon said intermediate portion will be parted thereby and be caused to closely hug and substantially encircle the intermediate portion of said melting pot.

12. In a pistol for applying metal coatings and fillings, a manual grip, a spraying head carried by said grip and having an atomizing nozzle consisting of associated compressed air and metal-spraying jets, an open-top stock-melting pot of, approximately one inch diameter disposed directly behind said atomizing nozzle and in which the end of conventional bar or strip stock may be vertically disposed and fed, a gas torch carried by said grip and disposed with its mouth facing said melting pot for directing a horizontal tongue of flame against the rear intermediate portion thereof, said intermediate portion of said melting pot being ovate in horizontal cross-section with its long horizontal axis disposed in the line of flame so that flame impinging upon said intermediate portion will be parted thereby and be caused to closely hug and substantially encircle the intermediate portion of said melting pot, and a flange intermediate said melting pot and atomizing nozzle disposed transverse the line of flame for maintaining said nozzle in heated condition and preventing passage of flame beyond said nozzle.

DONALD D. TAYLOR.

35	110
40	115
45	120
50	125
55	130
60	135
65	140
70	145
75	150