

(19) World Intellectual Property Organization
International Bureau



(43) International Publication Date
5 August 2004 (05.08.2004)

PCT

(10) International Publication Number
WO 2004/064682 A1

- (51) International Patent Classification⁷: **A61F 2/06**
- (21) International Application Number: PCT/KR2003/000145
- (22) International Filing Date: 23 January 2003 (23.01.2003)
- (25) Filing Language: Korean
- (26) Publication Language: English
- (71) Applicants (for all designated States except US): **TAEWOONG MEDICAL CO., LTD** [KR/KR]; 610, Ilsan Techno-Town, 1141-1, Baksuk-dong, Ilsan-gu, Koyang-si, 411-360 Kyunggi-do (KR). **NAM, Jeung Hee** [KR/KR]; 707-1508, Haan APT., Haan-dong, Gwangmyeong-si, 423-060 Kyunggi-do (KR).
- (71) Applicant and
- (72) Inventor: **SHIN, Kyong Min** [KR/KR]; 103-302, Gumsong Hills Vill, 458, Hongeun-dong, Seodaemun-gu, 120-100 Seoul (KR).
- (74) Agent: **CHUNG, Byung Ho**; 3F, Jeonwon Bldg., 669-6 Yeoksam-dong, Kangnam-gu, Seoul 135-915 (KR).
- (81) Designated States (national): AE, AG, AL, AM, AT, AU, AZ, BA, BB, BG, BR, BY, BZ, CA, CH, CN, CO, CR, CU, CZ, DE, DK, DM, DZ, EC, EE, ES, FI, GB, GD, GE, GH, GM, HR, HU, ID, IL, IN, IS, JP, KE, KG, KP, KZ, LC, LK, LR, LS, LT, LU, LV, MA, MD, MG, MK, MN, MW, MX, MZ, NO, NZ, OM, PH, PL, PT, RO, RU, SC, SD, SE, SG, SK, SL, TJ, TM, TN, TR, TT, TZ, UA, UG, US, UZ, VC, VN, YU, ZA, ZM, ZW.
- (84) Designated States (regional): ARIPO patent (GH, GM, KE, LS, MW, MZ, SD, SL, SZ, TZ, UG, ZM, ZW), Eurasian patent (AM, AZ, BY, KG, KZ, MD, RU, TJ, TM), European patent (AT, BE, BG, CH, CY, CZ, DE, DK, EE, ES, FI, FR, GB, GR, IE, IT, LU, MC, NL, PT, SE, SI, SK, TR), OAPI patent (BF, BJ, CF, CG, CI, CM, GA, GN, GQ, GW, ML, MR, NE, SN, TD, TG).

[Continued on next page]

(54) Title: LUMEN EXPANDING STENT AND METHOD FOR MAKING THE SAME

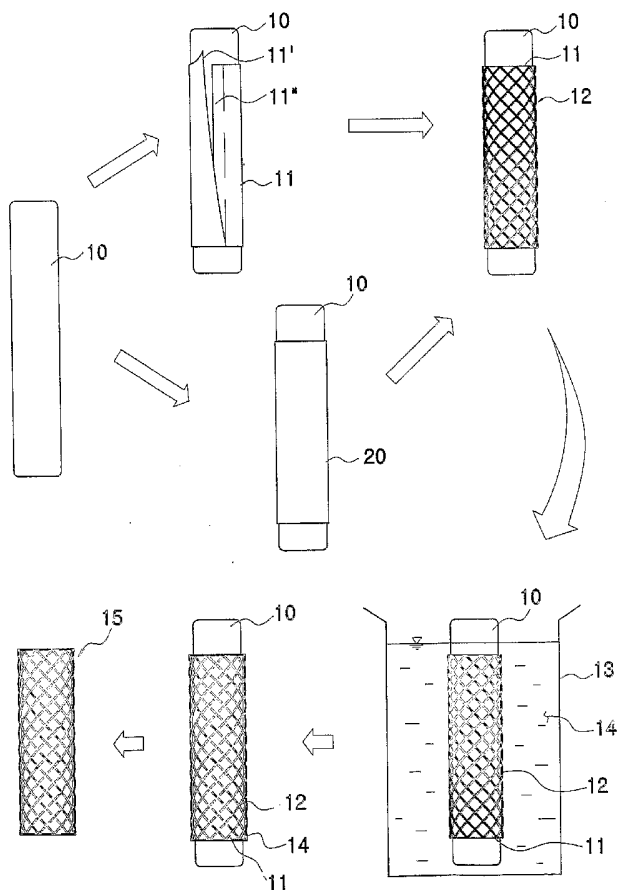

(57) Abstract: Disclosed herein is a lumen expanding stent comprising a selected stent adapted to a lesion site to be implanted therewith, a polytetrafluoro ethylene sheet tightly adhered to the inner surface of the selected stent, and a medical grade synthetic resin sheathed over the selected stent, wherein the medical grade synthetic resin is sheathed over the selected stent by dipping the polytetrafluoro ethylene sheet adhered to the inner surface of the selected stent in the medical grade synthetic resin, thereby integrally joining the polytetrafluoro ethylene sheet and the medical grade synthetic resin through the selected stent sandwiched therebetween. When the stent is implanted into a lumen or blood vessel, it can prevent a tumor, etc., which propagates at the outside of the stent, from penetrating into the inside of the stent. Further, blood, bile or food remnants can pass through the inside of the stent, without being deposited on wires constituting the stent.

WO 2004/064682 A1



Published:

— *with international search report*

For two-letter codes and other abbreviations, refer to the "Guidance Notes on Codes and Abbreviations" appearing at the beginning of each regular issue of the PCT Gazette.

LUMEN EXPANDING STENT AND METHOD FOR MAKING THE SAME

Technical Field

5 The present invention relates to a lumen expanding stent which is used for maintaining smooth blood circulation at a lesion site of the esophagus or blood vessel narrowed or occluded by lumen stenosis due to esophageal cancer, etc., or by arteriosclerosis, and for smooth flow of bile secreted from the liver. The present invention also relates to a method for making the lumen expanding stent.

Background Art

10 Generally, the narrowing of lumens due to a variety of diseases in the body leads to a loss of function of the lumens, and the narrowing of the blood vessels leads to poor blood circulation to develop diseases. A stent is a medical instrument that is surgically
15 implanted into the narrowed lumen or blood vessel to maintain them in an expanded state.

 As a representative example of the stent, a Palmaz type stent is described in U.S. Pat. No. 5,382,261.

20 The Palmaz type stent is effective when implanted into a narrowed lumen since it maintains its length even when contracted and expanded. However, the Palmaz type stent has a disadvantage that it is difficult to implant into a curved lumen or blood vessel, due to its poor flexibility.

25 Further, U.S. Pat. No. 4,655,771 discloses a so-called "wall type stent". Since the stent has self-expandability and flexibility of its own, it can be easily implanted into a curved lumen and blood vessel. However, since the length of the wall type stent varies upon contraction thereof, the diameter of the wall type stent is reduced at the curved location.

30 In addition to the above-mentioned patents, there are a number of patent publications relating to stents for expanding a lumen: for example, see Korean Patent Nos. 0240832, 0193269, 0170219 and 0170220, Korean Patent Laid-Open Nos. 1999-85314 and 1999-9743, and in particular Korean Patent No. 189094 issued to the present inventor, Korean Patent Laid-Open No. 1998-33463 and U.S. Pat. No. 6,027,525, etc.

35 Although these stents are different from one another in terms of manufacturing methods and shapes thereof, they all have a hollow cylindrical body shape formed by crossing or zigzagging metal alloy wires having a shape memory function.

 Since the above-mentioned stents are manufactured by crossing and zigzagging

one or more wires to form the hollow cylindrical body, a surface space 1 communicating with the inside of a stent 2 is formed, as shown in Figs. 1 and 2. Accordingly, in the case where the stent 2 is inserted to be placed in a narrowed esophagus or bile duct, the esophagus or bile duct can be expanded at stent's initial insertion stage.

5 As time goes by, cancer cells or remnants thereof propagate in the lumen and penetrate into the inside 3 of the stent 2 through the surface space 1. Accordingly, all prior art stents have a drawback requiring re-implantation although the time to carry out the re-implantation depends on the size of cancer cell mass.

10 In other words, the penetration of cancer cells or remnants thereof into the inside 3 of the stent 2 cannot be completely blocked.

To solve the drawback, a stent is disclosed in U.S. Pat. Nos. 5,545,211 and 5,330,500. According to these patents, the outer surface of the stent 2 is wrapped with a mesh and coated with a film made of polyurethane. Since the stent 2 has a polyurethane film layer on its outer surface, it can prevent cancer cells and remnants thereof from penetrating into the inside of the stent when implanted into a lumen.

15 The wrapping of the stent with the mesh facilitates the formation of the polyurethane film layer.

20 Although the polyurethane film layer is formed on the outer surface of the stent to prevent cancer cells and remnants thereof from penetrating into the inside of the stent, the wires and mesh constituting the stent are woven with each other and exposed to bile, food or blood remnants passing through the inside of the stent. Accordingly, as time goes by, the remnants are deposited on the wires and mesh and the stent cannot achieve its desired function.

25 To solve the problem of the above stent, an artificial blood vessel made of polytetrafluoro ethylene has been used to allow blood to flow unimpeded. However, since the artificial blood vessel is difficult to combine with the stent, the stent and the artificial blood vessel are separately implanted into a lumen.

30 Although the stent and the artificial blood vessel are separately implanted, the above-mentioned problem cannot be avoided since the artificial blood vessel is disposed on the outer surface of the stent.

The details are exemplified in Korean Patent Laid-Open No. 2000-61947, filed by the present inventor. Although largely different from the publication in the implantation method, U.S. Pat. No. 5,713,917 discloses an artificial graft similar to the above artificial blood vessel.

35 As can be seen from the above-mentioned patent publications, the stent and the artificial graft are separately implanted.

Disclosure of the Invention

Therefore, the present invention has been made in view of the above problems, and it is an object of the present invention to provide a lumen expanding stent which is used to prevent a tumor, etc., which propagates at the outside of the stent, from penetrating into the inside of the stent when the stent is implanted into a lumen or blood vessel.

It is another object of the present invention to provide a lumen expanding stent which is used for ensuring smooth flow of bile, food or blood remnants passing through the inside of the stent without being deposited on wires constituting the stent.

In order to achieve the above objects of the present invention, there is provided a composite lumen expanding stent, comprising:

a selected stent adapted to a lesion site to be implanted therewith;

a polytetrafluoro ethylene sheet tightly adhered to the inner surface of the selected stent; and

a medical grade synthetic resin sheathed over the selected stent,

wherein the medical grade synthetic resin is sheathed over the selected stent by dipping the polytetrafluoro ethylene sheet adhered to the inner surface of the selected stent in the medical grade synthetic resin, thereby integrally joining the polytetrafluoro ethylene sheet and the medical grade synthetic resin through the selected stent sandwiched therebetween.

In accordance with the present invention, the composite stent is first implanted into a lesion site. Although a tumor such as cancer is developed and grown at the lesion site where the composite stent is implanted, the medical grade synthetic resin sheathed over the selected stent can completely block the penetration of the tumor into the inside of the composite stent. Further, since blood, bile or food passing through the inside of the composite stent pass along the polytetrafluoro ethylene sheet adhered to the inner surface of the selected stent, their remnants cannot be deposited on the selected stent.

Brief Description of the Drawings

The above and other objects, features and other advantages of the present invention will be more clearly understood from the following detailed description taken in conjunction with the accompanying drawings, in which:

Figs. 1 and 2 are drawings showing a structure of a prior art stent;

Fig. 3 is an explanatory view showing stages in the manufacture of a composite stent according to the present invention;

Fig. 4 is a partial cross-sectional view showing a composite stent according to the present invention; and

Fig. 5 is a top view of showing a portion of Fig. 4.

5 Best Mode for Carrying Out the Invention

In Fig. 3, there are shown stages in the manufacture of a composite stent according to the present invention. In Fig. 4, there is shown a structure of a composite stent according to the present invention.

10 First, the diameter and length of the composite stent according to the present invention are determined in accordance with the size of lumen into which the composite stent is to be implanted. Next, a glass tube 10 having the same or similar diameter as the composite stent is selected.

15 A polytetrafluoro ethylene sheet 11 tightly surrounds the outer surface of the glass tube 10, and both ends 11' and 11" of the sheet 11 are joined to each other at their overlapping portion.

20 A stent 12 having a desired diameter is selected from conventional stents, manufactured by crossing and zigzagging wires, as described above. The selected stent 12 is fitted over the polytetrafluoro ethylene sheet 11 so that the stent 11 and the polytetrafluoro ethylene sheet 12 are tightly adhered to each other.

Accordingly, the polytetrafluoro ethylene sheet 11 is adhered onto the glass tube 10, and the selected stent 12 is adhered onto the polytetrafluoro ethylene sheet 11. The structure is then dipped in a container 13 filled with a medical grade synthetic resin 14.

25 At this step, it should be noted that the polytetrafluoro ethylene sheet 11 and the selected stent 12 are completely dipped in the medical grade synthetic resin 14.

The medical grade synthetic resin 14 is contacted with the polytetrafluoro ethylene sheet 11 through the selected stent 12 [except for points of contact between the selected stent 12 and polytetrafluoro ethylene sheet 11].

30 As a result, the selected stent 12 is disposed between the medical grade synthetic resin 14 formed at its outer surface and the polytetrafluoro ethylene sheet 11 formed at its inner surface.

35 The selected stent 12 sheathed with the medical grade synthetic resin 14 is taken out from the container 13. The medical grade synthetic resin 14 is then subjected to heat-drying. The glass tube 10 is pulled out from the polytetrafluoro ethylene sheet or broken to pieces to manufacture a composite stent 15 according to the present invention.

The composite stent 15 thus manufactured has a structure in which the

polytetrafluoro ethylene sheet 11 is adhered to the inner surface of the selected stent 12 and the medical grade synthetic resin 14 is sheathed over the selected stent 12, thereby integrally joining the polytetrafluoro ethylene sheet 11 and the medical grade synthetic resin 14 through the selected stent 12 sandwiched therebetween.

5 The composite stent 15 according to the present invention can be implanted into lesion sites such as lumen, the esophagus, a blood vessel, etc., in accordance with conventional stent implantation methods in the art.

10 Although a tumor such as cancer is developed and grown at a lesion site where the composite stent 15 is implanted, the medical grade synthetic resin 14 sheathed over the selected stent 12 can completely block the penetration of the tumor into the inside of the composite stent 15. Further, since blood, bile or food passing through the inside of the composite stent 15 pass along the polytetrafluoro ethylene sheet 11 adhered to the inner surface of the selected stent 12, their remnants cannot be deposited on the selected stent 12.

15 In particular, since the polytetrafluoro ethylene sheet 11 has a very slippery surface due to its material property, the remnants can easily pass along the sheet 11 without being deposited on the sheet 11.

20 In accordance with an aspect of the present invention, there is provided a method for making the composite stent 15. First, the polytetrafluoro ethylene sheet 11 adhered to the inner surface of the selected stent 12 is wound so as to be tightly adhered to the outer surface of the glass tube 10. Preferably, a polytetrafluoro ethylene tube 20 having the same or similar diameter as the selected stent 12 can be fitted over the glass tube 10.

25 In the present invention, the medical grade synthetic resin 14 may be currently used polyurethane, but the material is not particularly limited so long as it is not harmful to the human body and its liquid state is maintained. The material of the polytetrafluoro ethylene sheet 11 adhered to the inner surface of the selected stent 12 is not particularly limited, so long as it is not harmful to the human body and it is made into a sheet.

30 The use of the polytetrafluoro ethylene tube 20 in the manufacture of the composite stent 15 can avoid a disadvantage caused by using the polytetrafluoro ethylene sheet 11. That is, in the case of using the polytetrafluoro ethylene sheet 11 instead of the polytetrafluoro ethylene tube 20, there is a possibility that bile and blood vessel remnants are deposited on the overlapping portion of both ends 11' and 11'' of the sheet 11.

35 In accordance with the method for making the composite stent 15 of the present invention, a medical grade synthetic resin sheet (or a sheet having the same or similar properties to the medical grade synthetic resin sheet) is adhered to the inside of the selected stent 12 and is then dipped in a liquid state medical grade synthetic resin, thereby integrally joining the medical grade synthetic resin sheet (or the sheet having the same or similar

properties to the medical grade synthetic resin sheet) and the medical grade synthetic resin through the selected stent 12 sandwiched therebetween. Therefore, it is to be understood that all medical composite stents manufactured in accordance with various other modifications of the method according to the present invention belong to the scope of the invention.

Industrial Applicability

As can be seen from the foregoing, although a tumor such as cancer has developed and grown at a lesion site where the composite stent according to the present invention is implanted, the medical grade synthetic resin sheathed over the selected stent can completely block the penetration of the tumor into the inside of the composite stent. Further, since blood, bile or food passing through the inside of the composite stent pass along the polytetrafluoro ethylene sheet adhered to the inner surface of the selected stent, their remnants cannot be deposited on the selected stent. Therefore, the composite stent according to the present invention is useful for preventing blood vessel, bile and food remnants from being deposited on the selected stent.

Although the preferred embodiments of the present invention have been disclosed for illustrative purposes, those skilled in the art will appreciate that various modifications, additions and substitutions are possible, without departing from the scope and spirit of the invention as disclosed in the accompanying claims.

Claims:

1. A lumen expanding stent, comprising:
a selected stent 12 having a size and diameter suitable for a lesion site to be
5 implanted therewith and manufactured by crossing and zigzagging one or more wires;
a polytetrafluoro ethylene sheet 11 tightly adhered to the inner surface of the
selected stent 12; and
a medical grade synthetic resin 14 sheathed over the selected stent 12,
wherein the medical grade synthetic resin 14 is integrally joined to the
10 polytetrafluoro ethylene sheet 11 through the selected stent 12 sandwiched therebetween.
2. The lumen expanding stent according to claim 1, wherein the polytetrafluoro
ethylene sheet 11 is a polytetrafluoro ethylene tube 20.
- 15 3. A method for making a lumen expanding stent, comprising the steps of:
preparing a selected stent having a size and diameter suitable for a lesion site to be
implanted therewith by crossing and zigzagging one or more wires;
preparing a glass tube having the same or similar diameter as the selected stent,
tightly surrounding a polytetrafluoro ethylene sheet along an outer surface of the glass
20 tube, and joining both ends of the polytetrafluoro ethylene sheet to each other at their
overlapping portion;
inserting the selected stent into the polytetrafluoro ethylene sheet so that the stent
and the polytetrafluoro ethylene sheet are tightly adhered to each other, and dipping in a
container filled with a medical grade synthetic resin, thereby contacting the medical grade
25 synthetic resin with the polytetrafluoro ethylene sheet through the selected stent
sandwiched therebetween; and
taking out the selected stent sheathed with the medical grade synthetic resin from
the container, drying to integrally join the polytetrafluoro ethylene sheet and the medical
grade synthetic resin through the selected stent sandwiched therebetween, and separating
30 the glass tube from the polytetrafluoro ethylene sheet.
4. The method for making a lumen expanding stent according to claim 3, wherein
the polytetrafluoro ethylene sheet is a polytetrafluoro ethylene tube.

1/3
FIG. 1

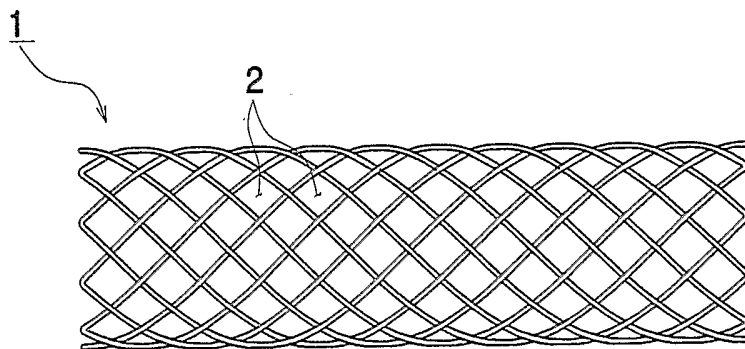
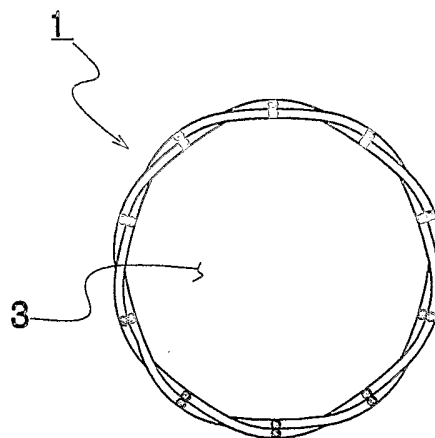
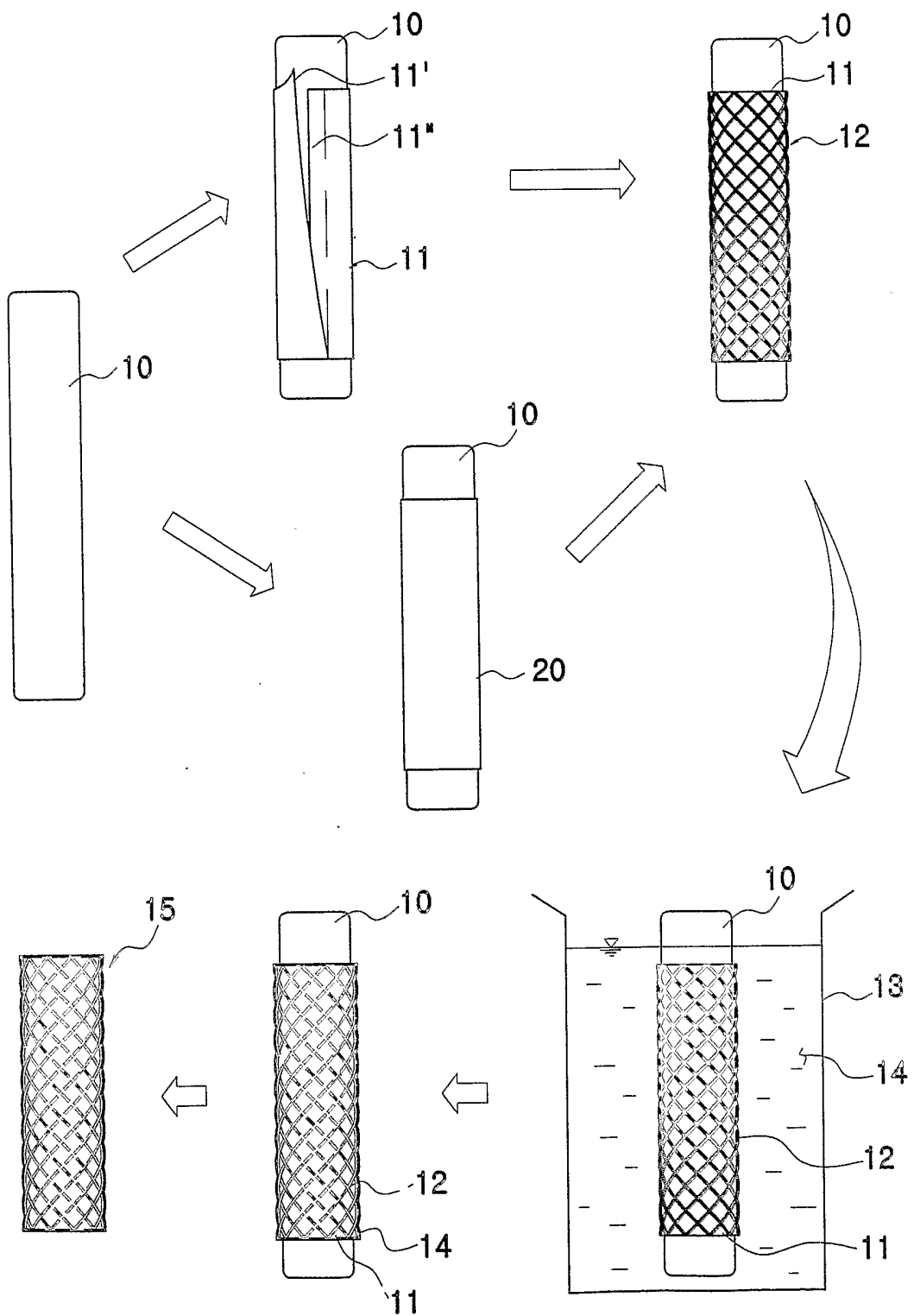

FIG. 2



2/3
FIG. 3



3/3
FIG. 4

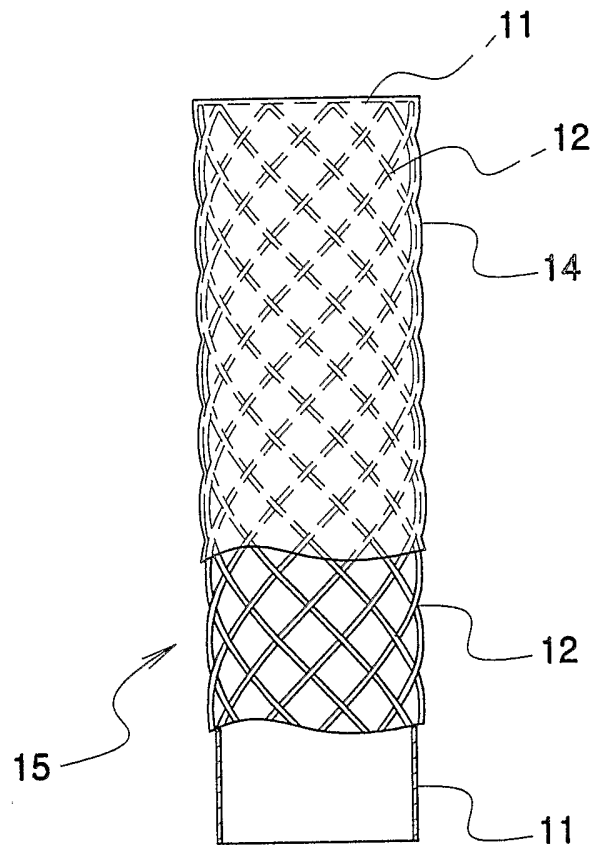
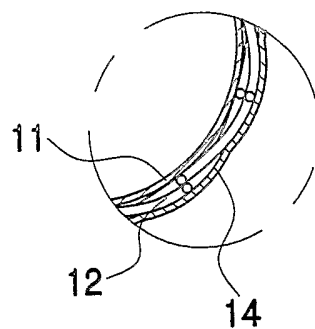

FIG. 5



INTERNATIONAL SEARCH REPORT

International application No.
PCT/KR03/00145

A. CLASSIFICATION OF SUBJECT MATTER <p style="text-align: center;">IPC7 A61F 2/06</p> <p>According to International Patent Classification (IPC) or to both national classification and IPC</p>				
B. FIELDS SEARCHED <p>Minimum documentation searched (classification system followed by classification symbols) IPC7 A61F, A61M, A61L</p> <p>Documentation searched other than minimum documentation to the extent that such documents are included in the fields searched Korean Patents and Applications for Inventions since 1975; Korean Utility Models and Applications for Utility Models since 1975 Japanese Utility Models and Applications for Utility Models since 1975</p> <p>Electronic data base consulted during the international search (name of data base and, where practicable, search terms used) eKIPASS</p>				
C. DOCUMENTS CONSIDERED TO BE RELEVANT				
Category*	Citation of document, with indication, where appropriate, of the relevant passages	Relevant to claim No.		
A	US 2002-0178570 A1 (Scimed Liffe Systems, Inc.) 5 Dec. 2002 See Claims	1 - 4		
A	US 2002-0065552 A1 (Jayaraman et al.) 30 May 2002 See Claims	1 - 4		
A	US 2002-0045931 A1 (Sogard et al.) 18 Apr.2002 See Claims	1 - 4		
<input type="checkbox"/> Further documents are listed in the continuation of Box C. <input checked="" type="checkbox"/> See patent family annex.				
<p>* Special categories of cited documents:</p> <table style="width: 100%; border: none;"> <tr> <td style="width: 50%; border: none; vertical-align: top;"> <p>"A" document defining the general state of the art which is not considered to be of particular relevance</p> <p>"E" earlier application or patent but published on or after the international filing date</p> <p>"L" document which may throw doubts on priority claim(s) or which is cited to establish the publication date of citation or other special reason (as specified)</p> <p>"O" document referring to an oral disclosure, use, exhibition or other means</p> <p>"P" document published prior to the international filing date but later than the priority date claimed</p> </td> <td style="width: 50%; border: none; vertical-align: top;"> <p>"T" later document published after the international filing date or priority date and not in conflict with the application but cited to understand the principle or theory underlying the invention</p> <p>"X" document of particular relevance; the claimed invention cannot be considered novel or cannot be considered to involve an inventive step when the document is taken alone</p> <p>"Y" document of particular relevance; the claimed invention cannot be considered to involve an inventive step when the document is combined with one or more other such documents, such combination being obvious to a person skilled in the art</p> <p>"&" document member of the same patent family</p> </td> </tr> </table>			<p>"A" document defining the general state of the art which is not considered to be of particular relevance</p> <p>"E" earlier application or patent but published on or after the international filing date</p> <p>"L" document which may throw doubts on priority claim(s) or which is cited to establish the publication date of citation or other special reason (as specified)</p> <p>"O" document referring to an oral disclosure, use, exhibition or other means</p> <p>"P" document published prior to the international filing date but later than the priority date claimed</p>	<p>"T" later document published after the international filing date or priority date and not in conflict with the application but cited to understand the principle or theory underlying the invention</p> <p>"X" document of particular relevance; the claimed invention cannot be considered novel or cannot be considered to involve an inventive step when the document is taken alone</p> <p>"Y" document of particular relevance; the claimed invention cannot be considered to involve an inventive step when the document is combined with one or more other such documents, such combination being obvious to a person skilled in the art</p> <p>"&" document member of the same patent family</p>
<p>"A" document defining the general state of the art which is not considered to be of particular relevance</p> <p>"E" earlier application or patent but published on or after the international filing date</p> <p>"L" document which may throw doubts on priority claim(s) or which is cited to establish the publication date of citation or other special reason (as specified)</p> <p>"O" document referring to an oral disclosure, use, exhibition or other means</p> <p>"P" document published prior to the international filing date but later than the priority date claimed</p>	<p>"T" later document published after the international filing date or priority date and not in conflict with the application but cited to understand the principle or theory underlying the invention</p> <p>"X" document of particular relevance; the claimed invention cannot be considered novel or cannot be considered to involve an inventive step when the document is taken alone</p> <p>"Y" document of particular relevance; the claimed invention cannot be considered to involve an inventive step when the document is combined with one or more other such documents, such combination being obvious to a person skilled in the art</p> <p>"&" document member of the same patent family</p>			
Date of the actual completion of the international search <p style="text-align: center;">21 OCTOBER 2003 (21.10.2003)</p>		Date of mailing of the international search report <p style="text-align: center;">21 OCTOBER 2003 (21.10.2003)</p>		
Name and mailing address of the ISA/KR Korean Intellectual Property Office 920 Dunsan-dong, Seo-gu, Daejeon 302-701, Republic of Korea Facsimile No. 82-42-472-7140		Authorized officer <p style="text-align: center;">LEE, Jung Hee</p> Telephone No. 82-42-481-5574 		

INTERNATIONAL SEARCH REPORT

Information on patent family members

International application No.

PCT/KR03/00145

Patent document cited in search report	Publication date	Patent family member(s)	Publication date
US 2002-0178570 A1	05.12.2002	None	
US 2002-0065552 A1	30.05.2002	AU 2001-85095 A5 WO 2002-15951 A2	04.03.2002 28.02.2002
US 2002-0045931 A1	18.04.2002	None	