



US00RE41567E

(19) **United States**
(12) **Reissued Patent**
Tsai et al.

(10) **Patent Number:** **US RE41,567 E**
(45) **Date of Reissued Patent:** **Aug. 24, 2010**

(54) **METHOD FOR OPTIMIZING THE BEST RESOLUTION OF AN OPTICAL SCANNING SYSTEM AND APPARATUS FOR THE SAME**

(76) Inventors: **Jenn-Tsair Tsai**, No. 56 Guangu S. St., Yangmei Township, Taoyuan County, 326 (TW); **June-Num Chen**, No. 41 Alley 39, Lane 324, Sec. 3, Wunchang Rd., Dadu Township, Taichung County, 432 (TW)

(21) Appl. No.: **11/786,468**

(22) Filed: **Apr. 10, 2007**
(Under 37 CFR 1.47)

Related U.S. Patent Documents

Reissue of:

(64) Patent No.: **6,879,412**
Issued: **Apr. 12, 2005**
Appl. No.: **09/635,223**
Filed: **Aug. 10, 2000**

(51) **Int. Cl.**
G06F 15/00 (2006.01)
G06K 1/00 (2006.01)

(52) **U.S. Cl.** **358/1.2**; 358/406; 358/504; 358/452; 358/482; 358/483; 235/454; 235/439; 235/462.32; 235/426.23; 382/312; 382/294; 348/222.1; 348/272; 359/385; 359/386

(58) **Field of Classification Search** 358/1.2, 358/1.3, 3.27, 504, 505, 516, 518, 520, 537, 358/448, 461, 474, 475, 482, 483, 486, 488, 358/497, 406, 452; 382/312, 287, 294; 348/222.1, 348/340, 294, 272; 359/385, 386, 210; 235/454, 235/439, 462.32, 426.23

See application file for complete search history.

(56) **References Cited**

U.S. PATENT DOCUMENTS

4,783,700	A	*	11/1988	Nagane	358/482
5,335,093	A	*	8/1994	Imoto	358/487
5,642,202	A		6/1997	Williams et al.		
6,016,207	A	*	1/2000	Wield	358/406
6,078,703	A	*	6/2000	Noguchi et al.	382/312
6,178,015	B1	*	1/2001	Lee et al.	358/486
6,178,018	B1	*	1/2001	Kekas et al.	359/9
6,219,463	B1	*	4/2001	Hyodo	382/298
6,222,934	B1	*	4/2001	Tsai	382/112
6,337,472	B1	*	1/2002	Garner et al.	250/201.3
6,377,362	B1	*	4/2002	Tsai et al.	358/406
6,557,762	B1	*	5/2003	Tsai et al.	235/454
6,734,903	B1	*	5/2004	Takeda et al.	348/219.1
6,809,842	B1	*	10/2004	Tsai et al.	358/471
6,814,288	B2	*	11/2004	Gurevich et al.	235/454
6,940,649	B2	*	9/2005	Dowski, Jr.	359/558
2008/0043126	A1	*	2/2008	Hayashi	348/294

* cited by examiner

Primary Examiner—Negussie Worku
(74) *Attorney, Agent, or Firm*—Perkins Coie LLP

(57) **ABSTRACT**

The present invention provides a method and an apparatus for fast finding the best resolution of an optical scanning device during assembling steps. The present invention improves the graphics of the calibration device. Accompanying with calculation of an adjustment device, the present invention generates a referencing parameters. The parameters represent the resolution of the optical scanning device; and further is able to show the balance of horizontal resolution and the balance of vertical resolution. In this case, technicians can optimize the best position of the lens in order to build an optical scanning with precision and narrow the misalignment during assembly.

27 Claims, 4 Drawing Sheets

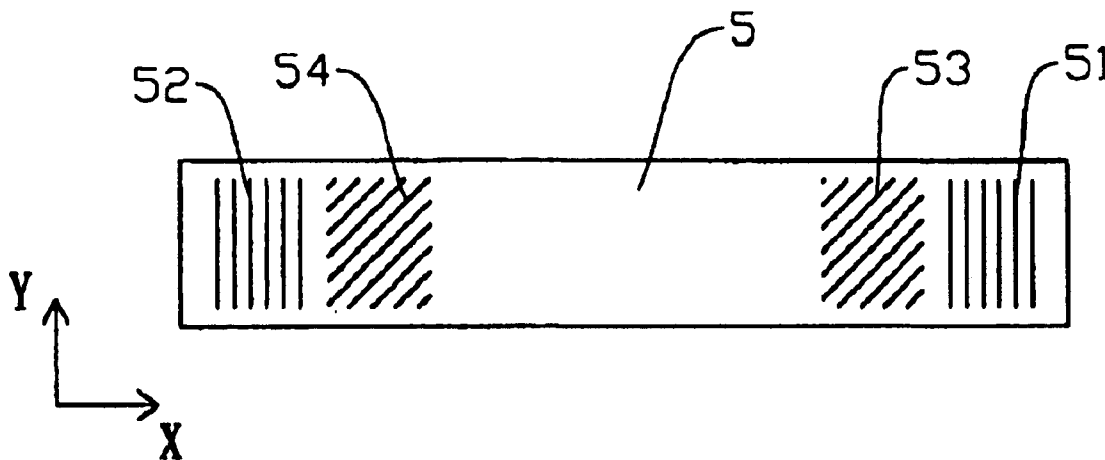

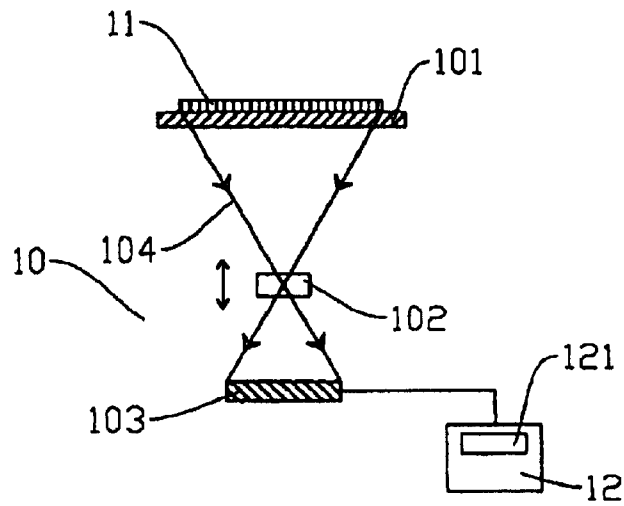

FIGURE 1(PRIOR ART)

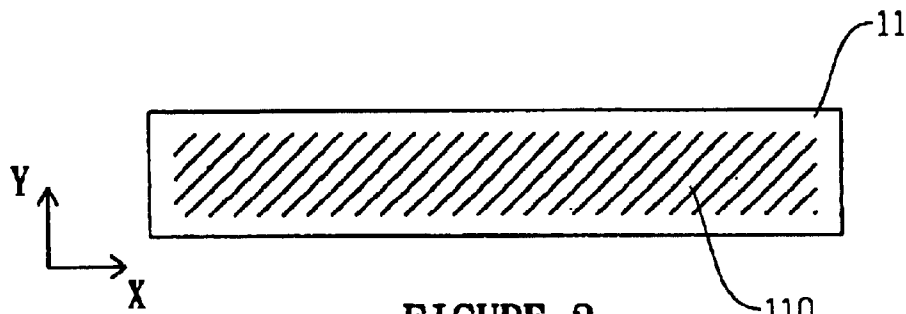

FIGURE 2

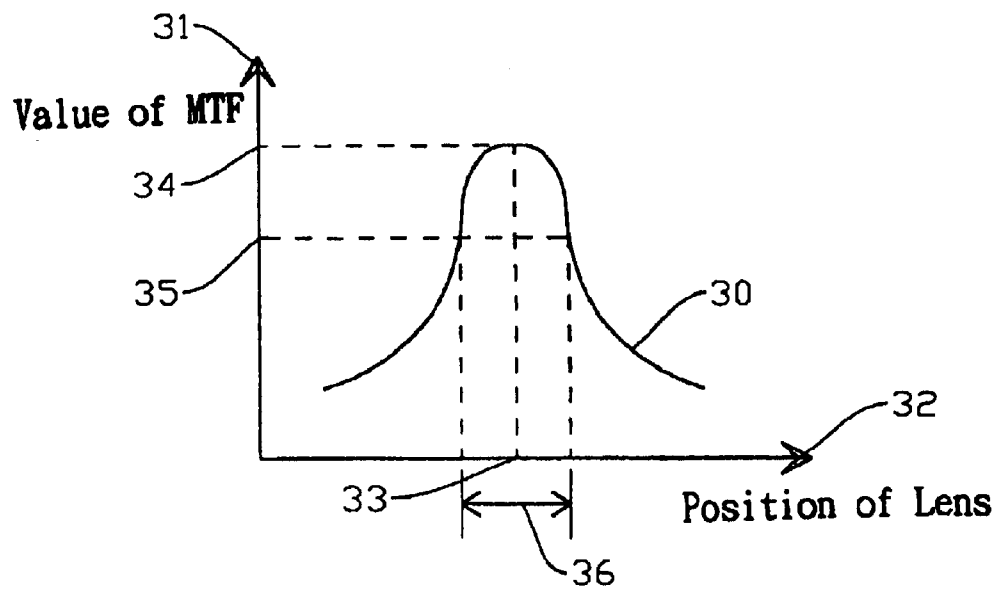

FIGURE 3

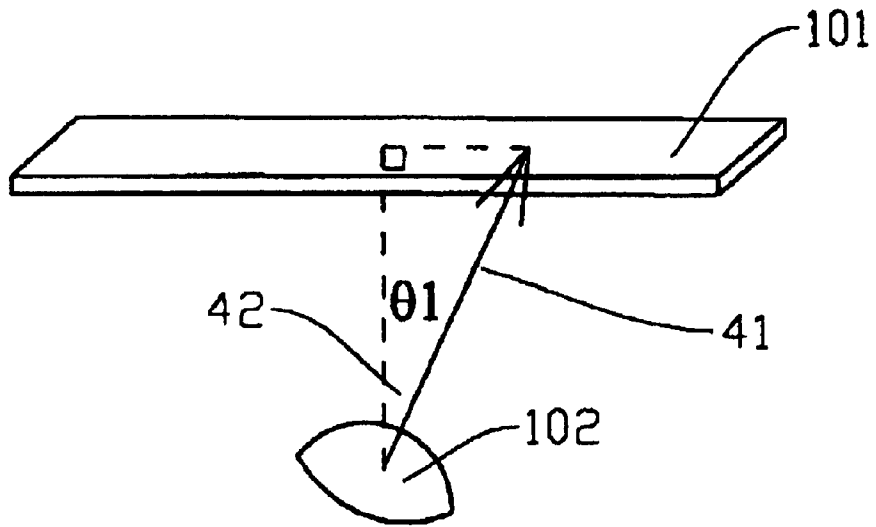

FIGURE 4A

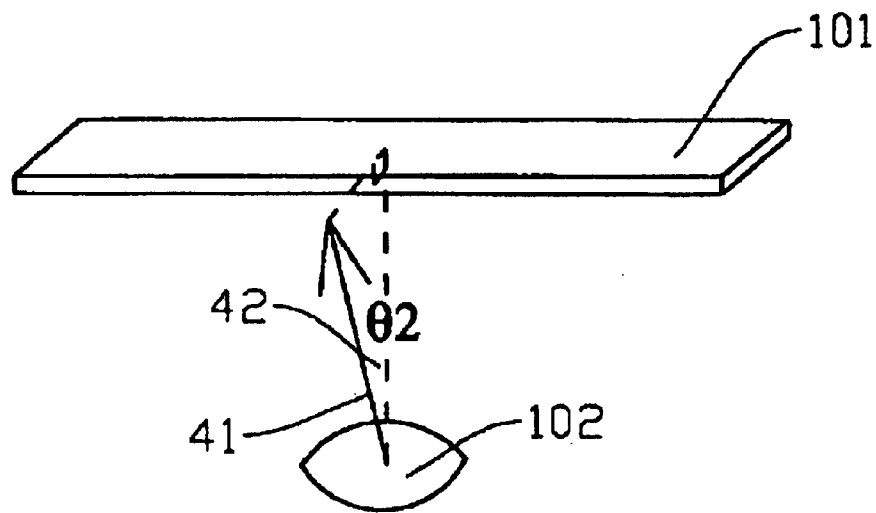

FIGURE 4B

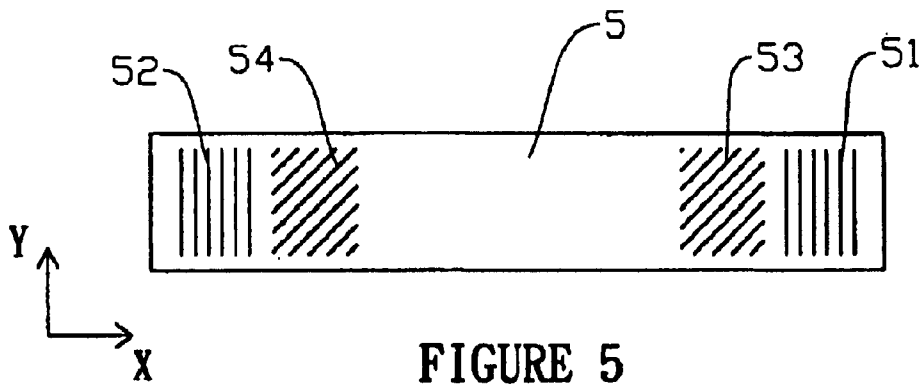

FIGURE 5

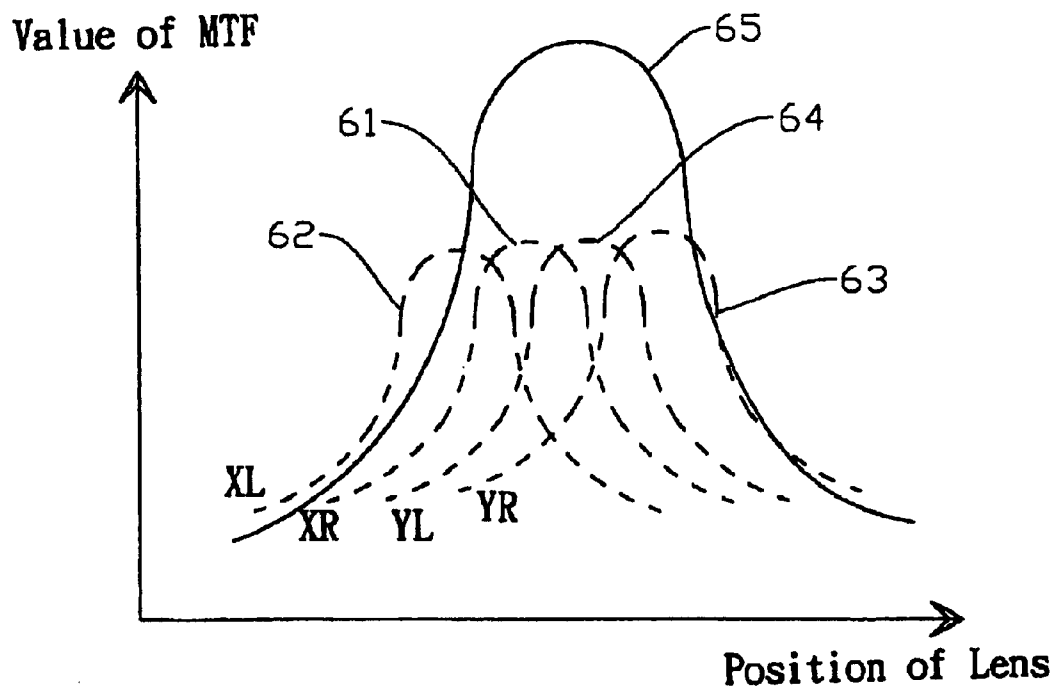

FIGURE 6

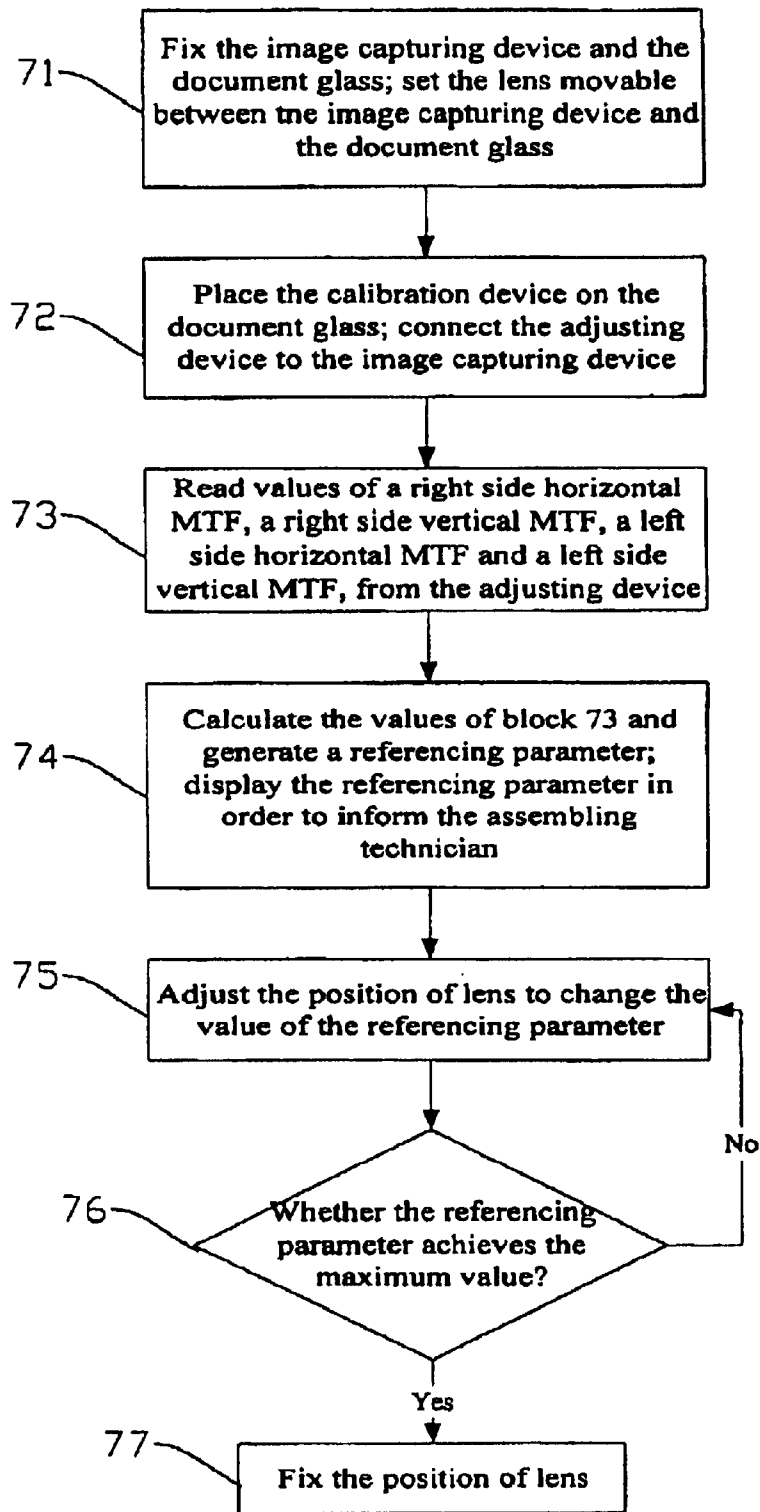

FIGURE 7

**METHOD FOR OPTIMIZING THE BEST
RESOLUTION OF AN OPTICAL SCANNING
SYSTEM AND APPARATUS FOR THE SAME**

Matter enclosed in heavy brackets [] appears in the original patent but forms no part of this reissue specification; matter printed in italics indicates the additions made by reissue.

BACKGROUND OF THE INVENTION

1. Field of the Invention

The present invention generally relates to a method and an apparatus for fast finding and optimizing the best resolution of an optical scanning device.

2. Background Description

Generally, an optical scanning system employs many components such as an image capturing device, lenses and so on, to assemble a scanning module with high precision. The scanning module can generate and record an image of an object after proper alignment and calibration. The scanning module further would be able to transform the captured image to digital signals with carrying out the visual image. In this case, the scanning process is completed. Therefore, a precise alignment and good assembly quality are a very important cause to the scanning module.

In FIG. 1, there is shown a traditional alignment and assembly method of a scanning module. The scanning module (not shown in FIG. 1) includes at least a scanning module 10 having a document glass 101, a lens 102 and an image capturing device 103. The image capturing device 103 generally is a Charged-Coupled Device (CCD). In addition, there are additional supporting device needed to assemble a traditional optical scanning system, such as calibration device 11, an adjusting device 12 connected to the image capturing device 103. The adjusting device 12 references signals from the image capturing device 103 for displaying parameters or signals, in order to inform the assembling technicians to identify the status of assembly.

Consequently, FIG. 2 shows the schematic demonstration of the calibration device 11. There is a print 110 on the surface of the calibration device 11. The print shows multi parallel lines, for calibration and detection purpose.

Further, please refer to FIG. 3. FIG. 3 shows a chart of Modulation Transfer Function (MTF)—Position of the Lens. The MTF is a known mathematic fiction. If the value of MTF 31 is higher, the resolution of the scanning module is greater. On the other hand, lower value of the MTF means lower resolution of the scanning module. The horizontal dimension of the chart represents the position of the lens 32. Usually, the curve 30 of the chart of the MTF-PL will be different for different scanning module 10. When the researching and developing engineers determine which scanning module is implemented, the curve 30 of the chart is fixed. Therefore, for a fixed shape of the chart of MTF-PL, there is a maximum value for the MTF. In theory, as shown in the figure, the best resolution of the scanning module will be achieved if the lens 34 is placed on the point where the value of MTF is the maximum. In practice, it is very difficult to assemble the scanning module precisely having the best resolution, namely, making the position of lens in the point where the MTF achieves the maximum value, due to the misalignment. Thus, if the value of the MITF can be set above a certain level, the resolution of the scanning module is acceptable by the user. In FIG. 3, if the point where the lens is placed is in the tolerant range 36, the value of the MTF of the scanning module will be kept above the MTF

tolerant value 35. In view of the above, the position of the lens is the major issue of the resolution of an optical scanning device.

Accordingly, the assembly of the traditional optical scanning device includes the steps of the followings. Firstly, the assembling technician mounts the document glass 101 and the image capturing device 103. The lens 102 is able to move along a specified direction linearly, as shown in FIG. 1. The lens is further temporarily fixed in a predetermined position. A calibration device 11 is placed on the document glass 101. The calibration device 11 contains a print 110. Please refer to FIG. 2. The optical scanning device further includes a light source (not shown in the figure). The light source provides a light illuminated on the document glass 101 and later reflected by the calibration device 11. The light is transmitted via an optical route 104 to the lens 102, and generated an image on the image capturing device 103. The image capturing device 103 generates digital signals. In this point, the adjusting device 12 calculates the MTF by referencing the digital signals and displays the result. In this case, the value of MTF presents the resolution of the calibration device 11, which is placed in the document glass 101. The assembling technician is therefore able to adjust the position of the lens in order to get the maximum value of MTF, and fixes the lens at the position where the value of MTF is maximum or above the MTF tolerant value. If the value of MTF is maximum, the best resolution of the optical scanning device is achieved.

The calibration device 110, described in the above for adjusting the scanning system, only has one print, and the print contains plural parallel lines. The vector on X-axis and the vector on Y-axis of the lines give the adjusting device 12 basis to calculate the value of MTF for representing the resolution of the X-axis and Y-axis. Moreover, some calibration devices only provide plural parallel lines in one direction, such as X-axis or Y-axis. In this case, the assembling technician only get the reference resolution in one direction. Practically, due to the misalignment of the assembly, the axis of the lens 102 is usually unable to be perpendicular to the document glass. Thus, the axis of the lens has an inclined angular with the X-axis or Y-axis, as shown in FIG. 4A. Upmost, there are possibly containing two inclinations along X-axis and Y-axis. In this case, the X-axis resolution and the Y-axis resolution of the same point are different. Therefore, the best position of the lens cannot be obtained in this respect. Since a standard resolution can be obtained via traditional skills, the quality of assembled scanning devices would be reduced if the position of the lens only relies on one direction, such as X-axis or Y-axis.

In view of the above, it is important to provide a method and an apparatus for optimizing the best resolution of an optical scanning device in this industry.

SUMMARY OF THE INVENTION

It is therefore an object of the present invention to provide a method and an apparatus for fast finding the best resolution of an optical scanning device in order to speed up and simplify the assembling processes.

It is another object of the present invention to provide a simplified assembling process in order to increase the product quality and to reduce the cost of the optical scanning device.

BRIEF DESCRIPTION OF THE DRAWINGS

The foregoing and other objects, aspects and advantages will be better understood from the following detailed description of a preferred embodiment of the invention with reference to the drawings, in which:

FIG. 1 is a schematic demonstration of a traditional scanning module;

FIG. 2 is a schematic demonstration of a calibration device;

FIG. 3 shows a chart of MTF-PL of a scanning module;

FIG. 4A shows the inclination along X-axis direction of a traditional optical scanning device;

FIG. 4B shows the inclination along X-axis direction of a traditional optical scanning device;

FIG. 5 shows the calibration device of the present invention;

FIG. 6 shows the chart of MTF-PL of the present invention; and

FIG. 7 shows a diagram illustrating assembling processes of the present invention.

DETAILED DESCRIPTION OF A PREFERRED EMBODIMENT OF THE INVENTION

The present invention is directed to an improvement of the print of the calibration device. By the calculation of the adjusting device, there is generated a referencing parameter for fast finding and optimizing the best position of the lens. In this case, a high precise assembling process is obtained and thus reduces the misalignment caused by different technicians with different skills.

Please refer to FIGS. 5 and 6. FIG. 5 shows the calibration device of the present invention. The X-axis direction is along horizontal direction shown in the lower-left position of FIG. 5. The Y-axis direction is along vertical direction. The calibration device 5 has an XR print 51. The print 51 contains a plurality of parallel perpendicular lines. When the technicians apply an adjusting device for assembling, the adjusting device will generate a parameter X_R for representing the right side of the horizontal resolution. The value of X_R will vary with different positions of the lens, shown as XR curve 61 of FIG. 6. In addition, the calibration device further has a YR print. The YR print contains a plurality of inclined parallel lines. The inclination angular is between zero and forty-five degrees from the horizontal direction. In this case, the adjusting device will generate a value of right side of MTF, denoted as legend Y_R . The value of Y_R represents the right side of the vertical resolution. The value of Y_R varies with different positions of the lens, shown as the YR curve 62 in the FIG. 6. Accordingly, the calibration device has an XL print and a YL print. The adjusting device is able to generate a left horizontal MTF value and a left vertical MTF value by the XL and YL prints, denoted as X_L and Y_L . The X_L and Y_L represents the left side horizontal resolution and the left side vertical resolution.

When the calibration device receive the parameters X_R , Y_R , X_L and Y_L , a total value of MTF, denoted as A, is generated as $A=X_R+X_L+Y_R+Y_L$. The legend A represents the total resolution of the scanning module. Larger value of A means better resolution.

Further, regarding the precision during assembly, the lens may incline along left and right directions or along front and rear directions. In this case, the resolution may be unable to be balanced. In order to overcome the above problems, a horizontal balance value is generated as $|X_R-X_L|$. Smaller $|X_R-X_L|$ means smaller difference of the horizontal resolution. Accordingly, the vertical balance value is $|Y_R-Y_L|$. Smaller $|Y_R-Y_L|$ means smaller difference of the vertical resolution. Moreover, a left side of the balance value is considered as $|X_L-Y_L|$. Smaller $|X_L-Y_L|$ means smaller difference between the left side of the vertical resolution and the

left side of the horizontal resolution. A right side of the balance value is considered as $|X_R-Y_R|$. Smaller $|X_R-Y_R|$ means smaller difference between the right side of the vertical resolution and the right side of the horizontal resolution.

Thus a balance value B of the M is considered as $B=|X_R-X_L|+|Y_R-Y_L|+|X_L-Y_L|+|X_R-Y_R|$. The value of B represent the sum of MTF balance values of the scanning module. Smaller value of B means better balance of the scanning module.

In view of the above, C is considered as a referencing parameter which is calculated as $C=A-B$. Larger C means better resolution and better balance of the scanning module.

The adjusting device further provides a display for displaying the parameters described in the above. The displaying method could be a digital type. The assembling technicians can reference the value of the parameters by the help of the display, during the assembling process. The displaying method could be a light indicating type. The technicians can reference the light in order to determine whether the parameters achieve the optimizing values. In this cases, the parameters can improve the assembling quality, regarding the resolution.

According to the calibration device and the adjusting device mentioned in the above, the method of the present invention for optimizing the best resolution is described as follows. Please refer to FIG. 7. FIG. 7 shows the diagram of the assembling processes. An assembling technician first fixes positions of an image capturing device and a document glass in predetermined positions. Further, a lens is positioned between the image capturing device and the document glass, maintaining movable status, as step 71. In step 72, a calibration device is placed on the document glass; and an adjusting device is connected to the image capturing device. The adjusting device is able to read values of a right side of horizontal MTF, a right side of vertical MTF, a left side of horizontal MTF and a left side of vertical MTF as shown in step 73. In step 74, the adjusting device is able to generate a adjusting parameter by referencing the values of the right side of horizontal MTF, the right of vertical MTF, the left side of horizontal MTF and the left side of vertical MTF. Consequently, the assembling technician adjusts the position of the lens and pay attention to the variances of the adjusting parameter, as illustrated in step 75. In step 76, the technician can observe the weather the adjusting parameter achieves the maximum value. If the adjusting parameter does not achieve the maximum value, the process will back to step 75. However, if the adjusting parameter achieves the maximum, the technician will fix the position of the lens, shown as step 77. In this case, the assembling processes are completed.

Although preferred embodiments of the present invention have been described in the forgoing description and illustrated in the accompanying drawings, it will be understood that the invention is not limited to the embodiments disclosed, but is capable of numerous rearrangements, modifications, and substituting of parts and elements without departing from the spirit and scope of the invention. Accordingly, the present invention is intended to encompass such rearrangements, modifications, and substitutions of parts and elements as fall within the scope of the appended claims.

What is claimed is:

1. A method for optimizing the [best] resolution of an optical scanning device, said method employed in assembling processes for enabling an assembling technician to find [the best] an acceptable resolution, said optical scanning device including at least an image capturing device, a lens

5

and a document glass, with support of a calibration device and an adjusting device, said method comprising [the steps of]:

[(1)] fixing said image capturing device and said document glass in a predetermined position, said lens is movable between said image capturing device and said document glass;

[(2)] placing said calibration device on said document glass and connecting said adjusting device to said image capturing device;

[(3)] reading values of a right side horizontal MTF, a right side vertical MTF, a left side horizontal MTF and a left side vertical MTF from said adjusting device;

[(4)] calculating the values of said right side horizontal MTF, said right side vertical MTF, said left side horizontal MTF and said left side vertical MTF to generate a referencing parameter, wherein said referencing parameter is displayed in order to inform said assembling technician; and

[(5)] adjusting the position of said lens, when the value of said referencing parameter achieving a relative big value, fixing said lens,]

wherein said referencing parameter *corresponds to a position of the lens and* is the sum of the values of said right side horizontal MTF, said right side vertical MTF, said left side horizontal MTF and said left side vertical MTF.

2. The method of claim 1, wherein the step[(4)] of generating[,] said referencing parameter is the difference between a value of a balance MTF and the sum of the values of said right side horizontal MTF, said right side vertical MTF, said left side horizontal MTF and said left side vertical MTF.

3. The method of claim 2, wherein the value of said balance MTF is the sum of the absolute value of left side horizontal MTF minus the right side horizontal [1] MTF and the absolute value of left side vertical MTF minus the right side vertical MTF.

4. The method of claim 2, wherein the value of said balance MTF is the sum of the absolute value of left side horizontal MTF minus the right side vertical MTF and the absolute value of left side vertical MTF minus the right side horizontal MTF.

5. The method of claim 2, wherein the value of said balance MTF is the sum of the absolute value of left side horizontal MTF minus the right side horizontal [1] MTF, the absolute value of left side vertical MTF minus the right side vertical MTF, the absolute value of left side horizontal MTF minus the right side vertical MTF and the absolute value of left side vertical MTF minus the right side horizontal MTF.

6. The method of claim 1, [wherein the step(4) of displaying, said adjusting device] further comprising a display for [display] displaying said referencing parameter.

7. The method of claim 6, wherein said display is a digital type display for displaying said referencing parameter.

8. The method of claim 6, wherein said display is a light indicating type display for displaying said referencing parameter.

9. The method of claim 1, wherein said image capturing device is a charged-coupled device.

10. A method for adjusting a resolution of an optical scanning device, the method comprising:

generating values of a right side horizontal Modulation Transfer Function (MTF), a right side vertical MTF, a left side horizontal MTF and a left side vertical MTF with an adjusting device; and

6

generating a referencing parameter comprising a sum of the values of the right side horizontal MTF, the right side vertical MTF, the left side horizontal MTF, and the left side vertical MTF with the adjusting device;

wherein the referencing parameter corresponds to a position of a lens of the optical scanning device.

11. The method of claim 10, further comprising:

calculating a value of a balance MTF; and

adjusting the reference parameter according to the value of the balance MTF.

12. The method of claim 11, wherein calculating the value of the balance MTF comprises calculating a sum of an absolute value of a difference between the values of the left side horizontal MTF and the right side horizontal MTF and an absolute value of a difference between the values of the left side vertical MTF and the right side vertical MTF.

13. The method of claim 11, wherein calculating the value of the balance MTF comprises calculating a sum of an absolute value of a difference between the values of the left side horizontal MTF and the right side vertical MTF and an absolute value of a difference between the values of the left side vertical MTF and the right side horizontal MTF.

14. The method of claim 11, wherein calculating the value of the balance MTF comprises calculating a sum of an absolute value of a difference between the values of the left side horizontal MTF and the right side vertical MTF, an absolute value of a difference between the values of the left side vertical MTF and the right side vertical MTF, an absolute value of a difference between the values of the left side horizontal MTF and the right side horizontal MTF, and an absolute value of a difference between the values of the left side vertical MTF and the right side horizontal MTF.

15. The method of claim 11, wherein adjusting the reference parameter comprises calculating a difference between the values of the balance MTF and the reference parameter.

16. An apparatus for changing a resolution of an optical scanning device, the apparatus comprising:

a calibration device comprising a plurality of images, wherein the calibration device is configured to be positioned on a document glass of the optical scanning device; and

an adjusting device configured to

receive image signals from an image capturing device of the optical scanning device, wherein the image signals are generated from the plurality of images of the calibration device,

generate values of a right side horizontal Modulation Transfer Function (MTF), a right side vertical MTF, a left side horizontal MTF and a left side vertical MTF from the image signals, and

generate a referencing parameter comprising a sum of the values of the right side horizontal MTF, the right side vertical MTF, the left side horizontal MTF, and the left side vertical MTF,

wherein the referencing parameter corresponds to a position of a lens of the optical scanning device.

17. The apparatus of claim 16, wherein the adjusting device is further configured to:

calculate a value of a balance MTF; and

adjust the reference parameter according to the value of the balance MTF.

18. The apparatus of claim 17, wherein the value of the balance MTF comprises a sum of an absolute value of a difference between the values of the left side horizontal MTF and the right side horizontal MTF and an absolute value of a difference between the values of the left side vertical MTF and the right side vertical MTF.

19. The apparatus of claim 17, wherein the value of the balance MTF comprises a sum of an absolute value of a difference between the values of the left side horizontal MTF and the right side vertical MTF and an absolute value of a difference between the values of the left side vertical MTF and the right side horizontal MTF.

20. The apparatus of claim 17, wherein the value of the balance MTF comprises a sum of an absolute value of a difference between the values of the left side horizontal MTF and the right side horizontal MTF, an absolute value of a difference between the values of the left side vertical MTF and the right side vertical MTF, an absolute value of a difference between the values of the left side horizontal MTF and the right side vertical MTF, and an absolute value of a difference between the values of the left side vertical MTF and the right side horizontal MTF.

21. The apparatus of claim 17, wherein the reference parameter comprises a difference between the values of the balance MTF and the reference parameter.

22. An apparatus for adjusting a resolution of an optical scanning device, the apparatus comprising:

means for receiving image signals from an image capturing device of the optical scanning device;

means for generating values of a right side horizontal Modulation Transfer Function (MTF), a right side vertical MTF, a left side horizontal MTF and a left side vertical MTF from the image signals; and

means for generating a referencing parameter comprising a sum of the values of the right side horizontal MTF, the right side vertical MTF, the left side horizontal MTF, and the left side vertical MTF;

wherein the referencing parameter corresponds to a position of a lens of the optical scanning device.

23. The apparatus of claim 22, further comprising:

means for calculating a value of a balance MTF; and

means for adjusting the reference parameter according to the value of the balance MTF.

24. The apparatus of claim 23, wherein the value of the balance MTF comprises a sum of an absolute value of the left side horizontal MTF minus the right side horizontal MTF and an absolute value of the left side vertical MTF minus the right side vertical MTF.

25. The apparatus of claim 23, wherein the value of the balance MTF comprises a sum of an absolute value of the left side horizontal MTF minus the right side vertical MTF and an absolute value of the left side vertical MTF minus the right side horizontal MTF.

26. The apparatus of claim 23, wherein the value of the balance MTF comprises a sum of an absolute value of the left side horizontal MTF minus the right side horizontal MTF, an absolute value of the left side vertical MTF minus the right side vertical MTF, an absolute value of the left side horizontal MTF minus the right side vertical MTF, and an absolute value of the left side vertical MTF minus the right side horizontal MTF.

27. The apparatus of claim 23, further comprising means for calculating a difference between the balance MTF and the reference parameter.

* * * * *