



- (51) International Patent Classification: *G02B 6/44* (2006.01)
- (21) International Application Number: PCT/US2021/041751
- (22) International Filing Date: 15 July 2021 (15.07.2021)
- (25) Filing Language: English
- (26) Publication Language: English
- (30) Priority Data: 63/054,080 20 July 2020 (20.07.2020) US
- (71) Applicant: **COMMSCOPE TECHNOLOGIES LLC** [US/US]; 1100 CommScope Place SE, Hickory, North Carolina 28602 (US).
- (72) Inventors: **DE LEON, Oscar Bran**; 983 Lacy Court, Belle Plaine, Minnesota 56011 (US). **MARCOUILLER, Thomas**.
- (74) Agent: **MYERS BIGEL, P.A.**; PO Box 37428, Raleigh, North Carolina 27627 (US).
- (81) Designated States (*unless otherwise indicated, for every kind of national protection available*): AE, AG, AL, AM, AO, AT, AU, AZ, BA, BB, BG, BH, BN, BR, BW, BY, BZ, CA, CH, CL, CN, CO, CR, CU, CZ, DE, DJ, DK, DM, DO, DZ, EC, EE, EG, ES, FI, GB, GD, GE, GH, GM, GT, HN, HR, HU, ID, IL, IN, IR, IS, IT, JO, JP, KE, KG, KH, KN, KP, KR, KW, KZ, LA, LC, LK, LR, LS, LU, LY, MA, MD, ME, MG, MK, MN, MW, MX, MY, MZ, NA, NG, NI, NO, NZ, OM, PA, PE, PG, PH, PL, PT, QA, RO, RS, RU, RW, SA, SC, SD, SE, SG, SK, SL, ST, SV, SY, TH, TJ, TM, TN, TR, TT, TZ, UA, UG, US, UZ, VC, VN, WS, ZA, ZM, ZW.

(54) Title: FAN-OUT ASSEMBLY FOR FIBER OPTIC CABLE

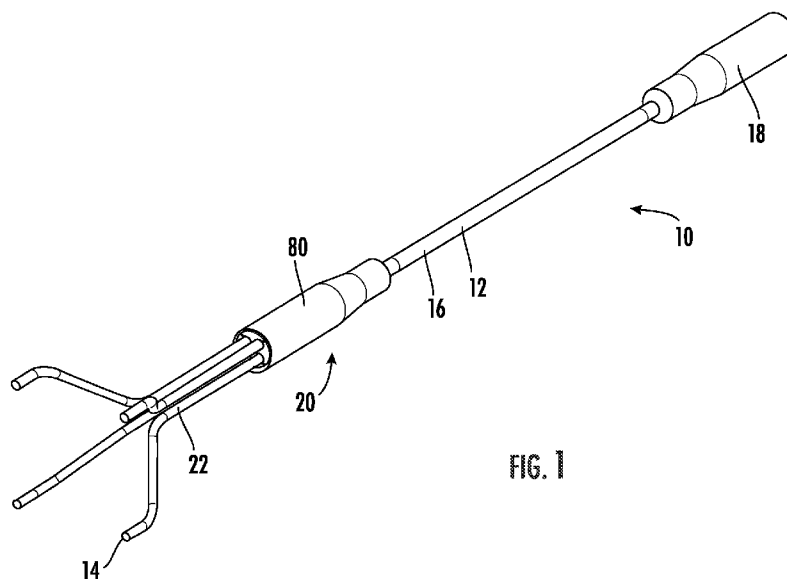

FIG. 1

(57) Abstract: An optical fan-out assembly includes: a fiber optic cable comprising a plurality of optical fibers and a surrounding jacket; a housing comprising first and second mating halves that mate to form a cavity, each of the first and second halves having opposite first and second ends and first and second lips adjacent respective first and second ends; the second half having a window, wherein the first lips create a seal with the cable jacket; a disk with a plurality of holes, a plurality of slots, and having a periphery, wherein a respective one of the plurality of slots extends between each hole and the periphery, the disk adjacent to and forming a seal with the second lips of the first and second halves; and a plurality of furcation tubes, each of the furcation tubes being inserted into a respective hole; wherein the optical fibers extend through the cavity, and each optical fiber is received in a respective furcation tube.



WO 2022/020165 A1

(84) Designated States (*unless otherwise indicated, for every kind of regional protection available*): ARIPO (BW, GH, GM, KE, LR, LS, MW, MZ, NA, RW, SD, SL, ST, SZ, TZ, UG, ZM, ZW), Eurasian (AM, AZ, BY, KG, KZ, RU, TJ, TM), European (AL, AT, BE, BG, CH, CY, CZ, DE, DK, EE, ES, FI, FR, GB, GR, HR, HU, IE, IS, IT, LT, LU, LV, MC, MK, MT, NL, NO, PL, PT, RO, RS, SE, SI, SK, SM, TR), OAPI (BF, BJ, CF, CG, CI, CM, GA, GN, GQ, GW, KM, ML, MR, NE, SN, TD, TG).

Published:

— *with international search report (Art. 21(3))*

FAN-OUT ASSEMBLY FOR FIBER OPTIC CABLE

Related Application

[0001] The present application claims priority from and the benefit of U.S. Provisional Patent Application No. 63/054,080, filed July 20, 2020, the disclosure of which is hereby incorporated herein by reference in its entirety.

Field of the Invention

[0002] The present invention relates generally to power and signal distribution, and more particularly to distribution from hybrid cables.

Background

[0003] Delivering power and data in wireless infrastructure typically involves the use of cable. In many instances, a single trunk cable can be used to supply multiple sectors, thereby eliminating multiple runs of cable. However, in order to use a single trunk cable, at some point the trunk cable must transition to jumper cables. For fiber optic cables, an enclosure may be used that transitions the multiple optical fibers of the trunk cable to individual optical fibers in the jumper cables. Typically this transition entails separating the optical fibers, removing any protective cladding or jacketing, and routing the individual optical fibers into furcation tubes or the like that exit the enclosure. The individual fibers are terminated with connectors that can then be attached to electronic equipment, such as remote radio heads or active antennas.

[0004] It may be desirable to provide enclosures that facilitate the assembly process.

Summary

[0005] As a first aspect, embodiments of the invention are directed to an optical fan-out assembly. The assembly comprises: a fiber optic cable comprising a plurality of optical fibers

and a surrounding jacket; a housing comprising first and second mating halves that mate to form a cavity, each of the first and second halves having opposite first and second ends and first and second lips adjacent respective first and second ends; the second half having a window, wherein the first lips create a seal with the cable jacket; a disk with a plurality of holes, a plurality of slots, and having a periphery, wherein a respective one of the plurality of slots extends between each hole and the periphery, the disk adjacent to and forming a seal with the second lips of the first and second halves; and a plurality of furcation tubes, each of the furcation tubes being inserted into a respective hole, The optical fibers extend through the cavity, and each optical fiber is received in a respective furcation tube.

[0006] As a second aspect, embodiments of the invention are directed to an optical fan-out assembly comprising: a fiber optic cable comprising a plurality of optical fibers and a surrounding jacket; a housing comprising first and second mating halves that mate to form a cavity, each of the first and second halves having opposite first and second ends and first and second lips adjacent respective first and second ends; the second half having a window, wherein the first lips create a seal with the cable jacket; a disk with a plurality of holes, a plurality of slots, and having a periphery, wherein a respective one of the plurality of slots extends between each hole and the periphery, the disk adjacent to and forming a seal with the second lips of the first and second halves; and a plurality of furcation tubes, each of the furcation tubes being inserted into a respective hole. The optical fibers extend through the cavity, and each optical fiber is received in a respective furcation tube. The assembly further comprises: a door that covers the window; and a cover that overlies the halves.

[0007] As a third aspect, embodiments of the invention are directed to a method of constructing a fiber optic fan-out assembly comprising the steps of:

(a) providing a fiber optic trunk cable comprising a plurality of optical fibers and a surrounding jacket;

(b) providing first and second halves of a housing, wherein the first and second halves mate to form a cavity, each of the first and second halves having opposite first and second ends and first and second lips adjacent respective first and second ends;

- (c) providing a disk with a plurality of holes, a plurality of slots, and having a periphery, wherein a respective one of the plurality of slots extends between each hole and the periphery;
- (d) exposing the optical fibers;
- (e) inserting each of the optical fibers through a respective slot in the disk and into a hole in the disk;
- (f) mating the halves of the housing to capture the cable jacket in the first lips and the disk with the optical fibers therein adjacent the second lips;
- (g) routing the optical fibers into respective furcation tubes; and
- (h) inserting furcation tubes into the holes.

Brief Description of the Figures

- [0008] **FIG. 1** is a perspective view of an optical fiber fan-out assembly according to embodiments of the invention.
- [0009] **FIG. 2** is an exploded perspective view of the assembly of **FIG. 1**.
- [0010] **FIG. 3** is an exploded front perspective view of the fan-out housing and alignment disk of the assembly of **FIG. 1**.
- [0011] **FIG. 4** is an exploded rear perspective view of the fan-out housing and alignment disk of the assembly of **FIG. 3**.
- [0012] **FIG. 5** is an enlarged, partial side section view of the assembly of **FIG. 1**.
- [0013] **FIG. 6** is a greatly enlarged front perspective view of one end of the housing of the assembly of **FIG. 1**.
- [0014] **FIG. 7** is a greatly enlarged rear perspective view of the housing as in **FIG. 6** with the alignment disk in place.
- [0015] **FIG. 8** is an enlarged perspective view of the furcation tubes and alignment disk of the assembly of **FIG. 1**.

Detailed Description

- [0016] The present invention now is described more fully hereinafter with reference to the accompanying drawings, in which embodiments of the invention are shown. This invention may,

however, be embodied in many different forms and should not be construed as limited to the embodiments set forth herein; rather, these embodiments are provided so that this disclosure will be thorough and complete, and will fully convey the scope of the invention to those skilled in the art.

[0017] In the figures, certain layers, components or features may be exaggerated for clarity, and broken lines illustrate optional features or operations unless specified otherwise. This invention may, however, be embodied in many different forms and should not be construed as limited to the embodiments set forth herein; rather, these embodiments are provided so that this disclosure will be thorough and complete, and will fully convey the scope of the invention to those skilled in the art.

[0018] It will be understood that, although the terms first, second, etc. may be used herein to describe various elements, components, regions, layers and/or sections, these elements, components, regions, layers and/or sections should not be limited by these terms. These terms are only used to distinguish one element, component, region, layer or section from another region, layer or section. Thus, a first element, component, region, layer or section discussed below could be termed a second element, component, region, layer or section without departing from the teachings of the present invention. The sequence of operations (or steps) is not limited to the order presented in the claims or figures unless specifically indicated otherwise.

[0019] Unless otherwise defined, all terms (including technical and scientific terms) used herein have the same meaning as commonly understood by one of ordinary skill in the art to which this invention belongs. It will be further understood that terms, such as those defined in commonly used dictionaries, should be interpreted as having a meaning that is consistent with their meaning in the context of the specification and relevant art and should not be interpreted in an idealized or overly formal sense unless expressly so defined herein. Well-known functions or constructions may not be described in detail for brevity and/or clarity.

[0020] The terminology used herein is for the purpose of describing particular embodiments only and is not intended to be limiting of the invention. As used herein, the singular forms "a", "an" and "the" are intended to include the plural forms as well, unless the context clearly indicates otherwise. It will be further understood that the terms "comprises" and/or "comprising", when used in this specification, specify the presence of stated features, integers, steps,

operations, elements, and/or components, but do not preclude the presence or addition of one or more other features, integers, steps, operations, elements, components, and/or groups thereof. As used herein, the term "and/or" includes any and all combinations of one or more of the associated listed items.

[0021] As used herein, phrases such as "between X and Y" and "between about X and Y" should be interpreted to include X and Y. As used herein, phrases such as "between about X and Y" mean "between about X and about Y." As used herein, phrases such as "from about X to Y" mean "from about X to about Y."

[0022] Referring now to the drawings, a fiber optic fan-out assembly, designated broadly at **10**, is shown in **FIGS. 1** and **2**. The assembly **10** includes a fiber optic trunk cable **12** that includes a plurality of optical fibers **14** within a jacket **16**. A connector **18** is attached at one end of the trunk cable **12**. The trunk cable **12** is routed at each end into a respective housing **18, 20** (the housing **18** may be similar to the housing **20**, such that the discussion below of the housing **20** may suffice for the housing **18** also).

[0023] Furcation tubes **22** exit the opposite end of the housing **20**, each protecting one or more optical fibers that are contained therein. Connectors (not shown) are attached at the ends of the optical fibers **14** opposite the housing **20** for connection with equipment, such as an RRU or an active antenna. The cable **12** and furcation tubes **22** may be of conventional construction and need not be described in detail herein.

[0024] Referring now to **FIGS. 2-4**, the housing **20** is shown in greater detail therein. The housing **20** is of a "clamshell" variety, with two halves **24, 26** mating to form an enclosure with a cavity **23** therein. As used herein, the term "half" is intended to mean one of two pieces that are mated to form the housing **20**, and is not intended to require that the two pieces be identical, or even of the same size. The halves **24, 26** are described in greater detail below.

[0025] The half **24** is generally semi-cylindrical, with a narrow neck **30**, a transition section **32**, and a wider body **34**. A lip **36** is present near the free end of the neck **30**. Another lip **38** is present near the free end of the body **34**. Four posts **40** extend generally parallel to each other: two posts **40** are positioned near the intersection of the transition section **32**, and two posts **40** are positioned near the lip **38**. A U-shaped guide **42** is located near the intersection of the transition

section **32** and the body **34**. A groove **44** is positioned on the inner surface of the half **24** between the end thereof and the lip **38**.

[0026] Referring still to **FIGS. 2-4**, the half **26** also has a neck **50**, a transition section **52** and a body **54** that are sized to mate with corresponding sections of the half **24**. The half **26** also includes lips **56, 58** that are sized and positioned to mate with, respectively, the lips **36, 38**, and a groove **59**. The half **26** also includes a window **60** in the body **34**. A separate door **62** with latches **64** at either end is sized to cover the window **60**. Holes **66** are positioned in the body **54** to receive the posts **40** from the half **24**.

[0027] The halves **24, 26** may be formed of any material, but are typically formed of a polymeric material such as a thermoplastic polyolefin.

[0028] A disk **70** is shown in **FIGS. 3, 6** and **8**. The disk **70** is round and includes four holes **72**. Each hole **72** is connected with the periphery of the disk **70** via a radially-extending slot **74**. The disk **70** is typically formed of a resilient material, such as rubber or plastic. The disk **70** is indicated to be round, but may take other forms, such as oval, rectangular, square, etc.,

[0029] Referring to **FIGS. 2** and **5**, a hollow cover **80** is shaped to circumferentially overlie the mated halves **24, 26** and a portion of the cable jacket **16**. In some embodiments, the cover **80** is formed of a heat-shrinkable material.

[0030] Construction of the assembly **10** proceeds in the following manner. The cover **80** is slipped onto the cable **12**. The jacket **16** of the cable **12** is stripped to a desired length, and the optical fibers **14** are separated and exposed (e.g., cladding or jacketing may be removed to expose the fiber). Each of the fibers **14** is then routed into a respective furcation tube **22**. An exposed portion of each fiber **14** is slipped through a respective slot **74** into the corresponding hole **72** in the disk **70**. Each of the furcation tubes **22** is inserted into the hole **72** in which its optical fiber resides.

[0031] Once all of the furcation tubes **22** are in place in the disk **70**, the disk **70** is positioned in the groove **44** of the half **24**, with the cable **12** resting in the guide **42**. In this position, the exposed portions of the optical fibers **14** are located within the cavity **23** between the guide **42** and the lip **38**. The half **26** is then mated to the half **24**, with the posts **40** being inserted into the holes **66**. Such mating aligns the lip **36** with the lip **56**, and the lip **38** with the lip **58**.

[0032] Notably, the mating of the lips **36, 56, 38, 58** forms watertight seals on each end of the housing **20**. More specifically, the lips **36, 56** form a seal with the jacket **16** of the cable **12** and with each other. The lips **38, 58** form a seal with each other, and abut the inner surface of the disk **70**. As such, the lips **38, 58** are positioned between the cavity **23** of the housing **20** and the slots **74** in the disk **70** and therefore provide a watertight seal between the cavity **23** and the slots **74**.

[0033] Those of skill in this art will appreciate that this sequence of assembly steps may vary. For example, the optical fibers **14** may be routed into the furcation tubes **22**, and the furcation tubes **22** installed in the holes **72**, after the disk **70** is captured in the mating halves **24, 26**. Other sequences of these steps may also be suitable to produce a subassembly that includes the cable **12**, the housing **20** and the furcation tubes **22**.

[0034] Once the halves **24, 26** are mated, epoxy or some other protective material can be introduced into the cavity **23** of the housing **20** through the window **60**. The seals formed by (a) the lips **36, 56** and the cable **12** and (b) the lips **38, 58** and the disk **70** may prevent leakage of the epoxy through the ends of the housing **20**. The door **62** is then installed in the half **26** to cover the window **60**, and the cover **80** is slid over the mated halves **24, 26** to maintain them in a mated condition. In some embodiments, the cover **80** is a heat-shrinkable material, such that the application of heat after the cover **80** is in place causes it to shrink and tightly hold the halves **24, 26** together.

[0035] The foregoing is illustrative of the present invention and is not to be construed as limiting thereof. Although exemplary embodiments of this invention have been described, those skilled in the art will readily appreciate that many modifications are possible in the exemplary embodiments without materially departing from the novel teachings and advantages of this invention. Accordingly, all such modifications are intended to be included within the scope of this invention as defined in the claims. The invention is defined by the following claims, with equivalents of the claims to be included therein.

That Which is Claimed is:

1. An optical fan-out assembly, comprising:
 - a fiber optic cable comprising a plurality of optical fibers and a surrounding jacket;
 - a housing comprising first and second mating halves that mate to form a cavity, each of the first and second halves having opposite first and second ends and first and second lips adjacent respective first and second ends; the second half having a window, wherein the first lips create a seal with the cable jacket;
 - a disk with a plurality of holes, a plurality of slots, and having a periphery, wherein a respective one of the plurality of slots extends between each hole and the periphery, the disk adjacent to and forming a seal with the second lips of the first and second halves;
 - a plurality of furcation tubes, each of the furcation tubes being inserted into a respective hole;
 - wherein the optical fibers extend through the cavity, and each optical fiber is received in a respective furcation tube.

2. The assembly defined in Claim 1, wherein each of the halves includes a groove adjacent the second lip, and wherein the disk is received within the grooves.

3. The assembly defined in Claim 1 or Claim 2, further comprising epoxy within the cavity.

4. The assembly defined in any of Claims 1-3, further comprising a door that covers the window.

5. The assembly defined in any of Claim 1-4, further comprising a cover that overlies the halves.

6. The assembly defined in Claim 5, wherein the cover comprises a heat-shrinkable material.

7. The assembly defined in any of Claims 1-6, wherein each of the first and second halves includes press-fit features.

8. An optical fan-out assembly, comprising:
a fiber optic cable comprising a plurality of optical fibers and a surrounding jacket;
a housing comprising first and second mating halves that mate to form a cavity, each of the first and second halves having opposite first and second ends and first and second lips adjacent respective first and second ends; the second half having a window, wherein the first lips create a seal with the cable jacket;

a disk with a plurality of holes, a plurality of slots, and having a periphery, wherein a respective one of the plurality of slots extends between each hole and the periphery, the disk adjacent to and forming a seal with the second lips of the first and second halves;

a plurality of furcation tubes, each of the furcation tubes being inserted into a respective hole;

wherein the optical fibers extend through the cavity, and each optical fiber is received in a respective furcation tube;

further comprising a door that covers the window; and
a cover that overlies the halves.

9. The assembly defined in Claim 8, wherein each of the halves includes a groove adjacent the second lip, and wherein the disk is received within the grooves.

10. The assembly defined in Claim 8 or Claim 9, further comprising epoxy within the cavity.

11. The assembly defined in any of Claims 8-10, wherein the cover comprises a heat-shrinkable material.

12. The assembly defined in any of Claims 8-11, wherein each of the first and second halves includes press-fit features.

13. A method of constructing a fiber optic fan-out assembly, comprising the steps of:
- (a) providing a fiber optic trunk cable comprising a plurality of optical fibers and a surrounding jacket;
 - (b) providing first and second halves of a housing, wherein the first and second halves mate to form a cavity, each of the first and second halves having opposite first and second ends and first and second lips adjacent respective first and second ends;
 - (c) providing a disk with a plurality of holes, a plurality of slots, and having a periphery, wherein a respective one of the plurality of slots extends between each hole and the periphery;
 - (d) exposing the optical fibers;
 - (e) inserting each of the optical fibers through a respective slot in the disk and into a hole in the disk;
 - (f) mating the halves of the housing to capture the cable jacket in the first lips and the disk with the optical fibers therein adjacent the second lips;
 - (g) routing the optical fibers into respective furcation tubes; and
 - (h) inserting furcation tubes into the holes.

14. The method defined in Claim 13, wherein each of the halves includes a groove adjacent the second lip, and wherein the disk is received within the grooves.

15. The method defined in Claim 13 or Claim 14, further comprising introducing epoxy into the cavity through the window.

16. The method defined in any of Claims 13-15, further comprising installing a door that covers the window.

17. The method defined in any of Claims 13-16, further comprising applying a cover that overlies the halves.

18. The method defined in Claim 17, wherein the cover comprises a heat-shrinkable material, and wherein the applying step comprises applying heat to the cover to shrink onto the housing.

19. The method defined in any of Claims 13-18, wherein each of the first and second halves includes press-fit features, and wherein the mating step comprises press-fitting the features of the first half onto the features of the second half.

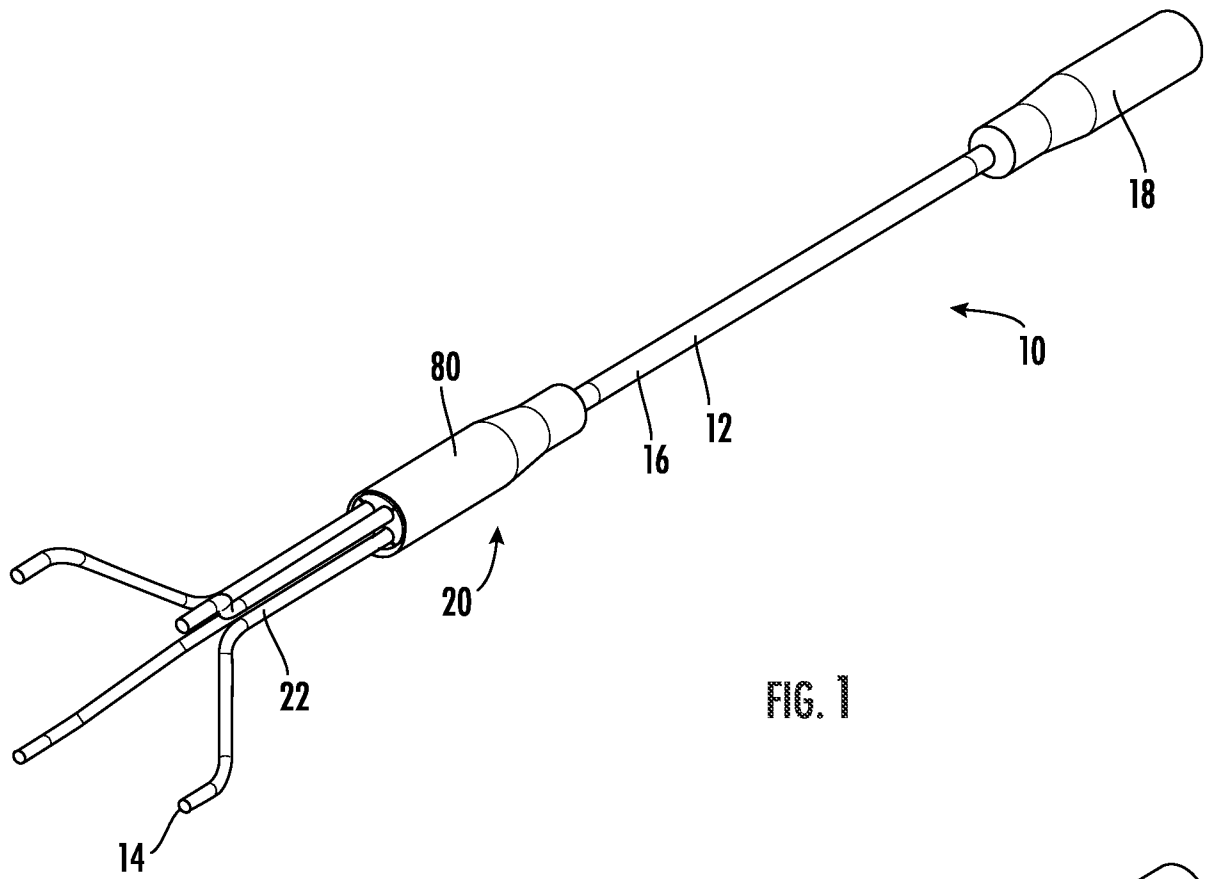

FIG. 1

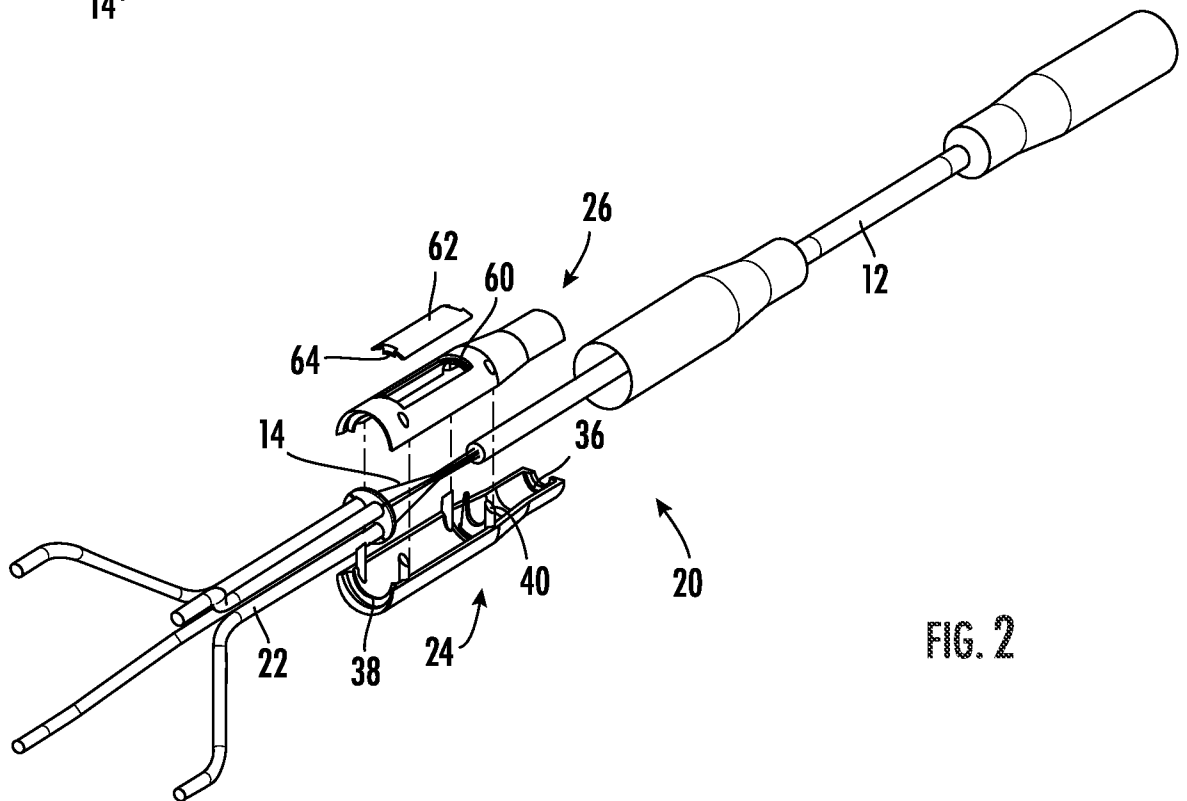

FIG. 2

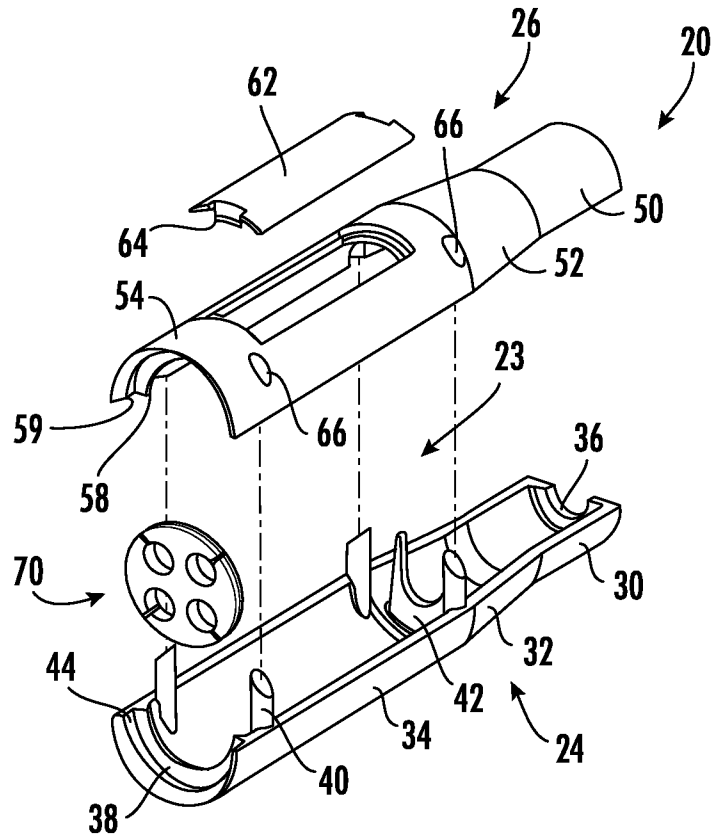

FIG. 3

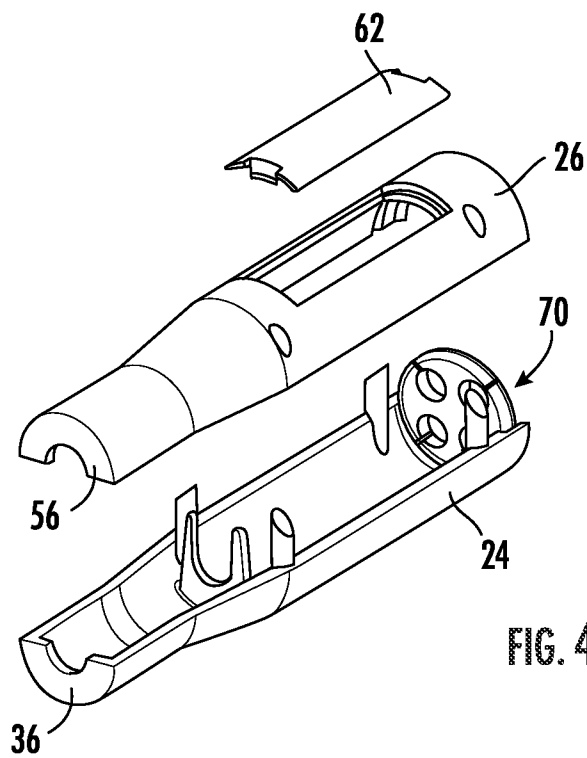

FIG. 4

INTERNATIONAL SEARCH REPORT

International application No.

PCT/US2021/041751

A. CLASSIFICATION OF SUBJECT MATTER G02B 6/44(2006.01)i		
According to International Patent Classification (IPC) or to both national classification and IPC		
B. FIELDS SEARCHED		
Minimum documentation searched (classification system followed by classification symbols) G02B 6/44(2006.01); G02B 6/255(2006.01); G02B 6/38(2006.01)		
Documentation searched other than minimum documentation to the extent that such documents are included in the fields searched Korean utility models and applications for utility models Japanese utility models and applications for utility models		
Electronic data base consulted during the international search (name of data base and, where practicable, search terms used) eKOMPASS(KIPO internal) & Keywords: optical fiber cable, fan-out, routing, furcation, connector, sealing		
C. DOCUMENTS CONSIDERED TO BE RELEVANT		
Category*	Citation of document, with indication, where appropriate, of the relevant passages	Relevant to claim No.
X	US 2020-0033535 A1 (COMMSCOPE TECHNOLOGIES LLC) 30 January 2020 (2020-01-30) paragraphs [0036], [0047]-[0075], [0090]-[0097]; claim 12; and figures 1-14	1-4,7,13-16,19
Y		5-6,8-12,17-18
Y	US 2015-0370029 A1 (ADC TELECOMMUNICATIONS, INC. et al.) 24 December 2015 (2015-12-24) paragraph [0040]; claim 9; and figure 5	5-6,8-12,17-18
A	US 2019-0285810 A1 (COMMSCOPE, INC. OF NORTH CAROLINA) 19 September 2019 (2019-09-19) paragraphs [0007]-[0053]; and figures 4-13	1-19
A	US 2019-0187396 A1 (COMMSCOPE TECHNOLOGIES LLC) 20 June 2019 (2019-06-20) paragraphs [0041]-[0054]; and figures 1-9	1-19
A	US 2014-0241676 A1 (MATTHEW WADE SMITH) 28 August 2014 (2014-08-28) paragraphs [0068]-[0088]; and figures 5A-8K	1-19
<input type="checkbox"/> Further documents are listed in the continuation of Box C. <input checked="" type="checkbox"/> See patent family annex.		
* Special categories of cited documents: "A" document defining the general state of the art which is not considered to be of particular relevance "D" document cited by the applicant in the international application "E" earlier application or patent but published on or after the international filing date "L" document which may throw doubts on priority claim(s) or which is cited to establish the publication date of another citation or other special reason (as specified) "O" document referring to an oral disclosure, use, exhibition or other means "P" document published prior to the international filing date but later than the priority date claimed "T" later document published after the international filing date or priority date and not in conflict with the application but cited to understand the principle or theory underlying the invention "X" document of particular relevance; the claimed invention cannot be considered novel or cannot be considered to involve an inventive step when the document is taken alone "Y" document of particular relevance; the claimed invention cannot be considered to involve an inventive step when the document is combined with one or more other such documents, such combination being obvious to a person skilled in the art "&" document member of the same patent family		
Date of the actual completion of the international search 04 November 2021		Date of mailing of the international search report 04 November 2021
Name and mailing address of the ISA/KR Korean Intellectual Property Office 189 Cheongsa-ro, Seo-gu, Daejeon 35208, Republic of Korea Facsimile No. +82-42-481-8578		Authorized officer PARK, Hye Lyun Telephone No. +82-42-481-3463

INTERNATIONAL SEARCH REPORT
Information on patent family members

International application No.

PCT/US2021/041751

Patent document cited in search report			Publication date (day/month/year)	Patent family member(s)			Publication date (day/month/year)
US	2020-0033535	A1	30 January 2020	EP	3580594	A1	18 December 2019
				EP	3580594	A4	25 November 2020
				US	10928592	B2	23 February 2021
				WO	2018-148402	A1	16 August 2018

US	2015-0370029	A1	24 December 2015	US	09395509	B2	19 July 2016
				WO	2015-200321	A1	30 December 2015

US	2019-0285810	A1	19 September 2019	US	09429721	B2	30 August 2016
				US	09995885	B2	12 June 2018
				US	10317629	B2	11 June 2019
				US	10823918	B2	03 November 2020
				US	2014-219613	A1	07 August 2014
				US	2016-363733	A1	15 December 2016
				US	2018-292615	A1	11 October 2018
				WO	2014-121034	A1	07 August 2014

US	2019-0187396	A1	20 June 2019	BR	112019002758	A2	14 May 2019
				EP	3497499	A1	19 June 2019
				EP	3497499	A4	01 April 2020
				MX	2019001845	A	09 May 2019
				US	10739545	B2	11 August 2020
				US	2020-371308	A1	26 November 2020

US	2014-0241676	A1	28 August 2014	US	09069152	B2	30 June 2015
