

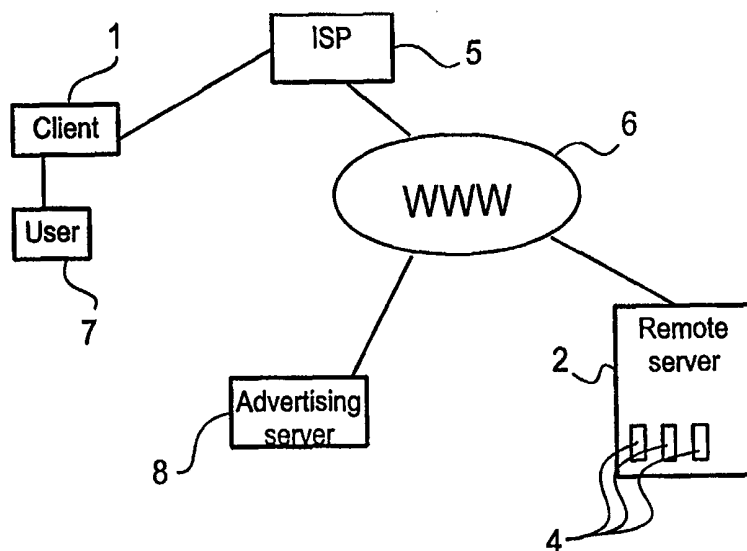

INTERNATIONAL APPLICATION PUBLISHED UNDER THE PATENT COOPERATION TREATY (PCT)

<p>(51) International Patent Classification ⁷ : G06F 17/30</p>	<p>A1</p>	<p>(11) International Publication Number: WO 00/29982 (43) International Publication Date: 25 May 2000 (25.05.00)</p>
<p>(21) International Application Number: PCT/SE99/02058 (22) International Filing Date: 11 November 1999 (11.11.99) (30) Priority Data: 09/189,851 12 November 1998 (12.11.98) US (71) Applicant (for all designated States except US): BIP BOTTNIA INTERNET PROVIDER AB [SE/SE]; Tegnérgatan 2 B, S-113 58 Stockholm (SE). (72) Inventor; and (75) Inventor/Applicant (for US only): LÖVBRAND, Anders [SE/SE]; Birger Jarlsgatan 104, U6, 3 trp, S-114 20 Stockholm (SE). (74) Agent: AWAPATENT AB; P.O. Box 11394, S-404 28 Göteborg (SE).</p>		<p>(81) Designated States: AE, AL, AM, AT, AT (Utility model), AU, AZ, BA, BB, BG, BR, BY, CA, CH, CN, CR, CU, CZ, CZ (Utility model), DE, DE (Utility model), DK, DK (Utility model), DM, EE, EE (Utility model), ES, FI, FI (Utility model), GB, GD, GE, GH, GM, HR, HU, ID, IL, IN, IS, JP, KE, KG, KP, KR, KZ, LC, LK, LR, LS, LT, LU, LV, MA, MD, MG, MK, MN, MW, MX, NO, NZ, PL, PT, RO, RU, SD, SE, SG, SI, SK, SK (Utility model), SL, TJ, TM, TR, TT, TZ, UA, UG, US, UZ, VN, YU, ZA, ZW, ARIPO patent (GH, GM, KE, LS, MW, SD, SL, SZ, TZ, UG, ZW), Eurasian patent (AM, AZ, BY, KG, KZ, MD, RU, TJ, TM), European patent (AT, BE, CH, CY, DE, DK, ES, FI, FR, GB, GR, IE, IT, LU, MC, NL, PT, SE), OAPI patent (BF, BJ, CF, CG, CI, CM, GA, GN, GW, ML, MR, NE, SN, TD, TG).</p> <p>Published With international search report.</p>

(54) Title: METHOD FOR IDENTIFYING A USER OF A NETWORK



(57) Abstract

The invention relates to a method for identifying a user of a network, such as the Internet, said network including several clients and several remote servers. At least one remote server is adapted to provide at least one client with a network accessible document, such as a hypertext document, in response to a request transmitted by the client to said remote server. The method includes the steps of defining at least one individual user profile consisting of information about the user, such as age, sex, interests, etc., and being provided by the user, storing said at least one predefined user profile in a memory means associated with the client, selecting one of said at least one predefined user profile in accordance with the user that is currently using the client for accessing the network, communicating the selected user profile to the remote server, and receiving the selected user profile at the remote server, before said document is provided to the client.

FOR THE PURPOSES OF INFORMATION ONLY

Codes used to identify States party to the PCT on the front pages of pamphlets publishing international applications under the PCT.

AL	Albania	ES	Spain	LS	Lesotho	SI	Slovenia
AM	Armenia	FI	Finland	LT	Lithuania	SK	Slovakia
AT	Austria	FR	France	LU	Luxembourg	SN	Senegal
AU	Australia	GA	Gabon	LV	Latvia	SZ	Swaziland
AZ	Azerbaijan	GB	United Kingdom	MC	Monaco	TD	Chad
BA	Bosnia and Herzegovina	GE	Georgia	MD	Republic of Moldova	TG	Togo
BB	Barbados	GH	Ghana	MG	Madagascar	TJ	Tajikistan
BE	Belgium	GN	Guinea	MK	The former Yugoslav Republic of Macedonia	TM	Turkmenistan
BF	Burkina Faso	GR	Greece			TR	Turkey
BG	Bulgaria	HU	Hungary	ML	Mali	TT	Trinidad and Tobago
BJ	Benin	IE	Ireland	MN	Mongolia	UA	Ukraine
BR	Brazil	IL	Israel	MR	Mauritania	UG	Uganda
BY	Belarus	IS	Iceland	MW	Malawi	US	United States of America
CA	Canada	IT	Italy	MX	Mexico	UZ	Uzbekistan
CF	Central African Republic	JP	Japan	NE	Niger	VN	Viet Nam
CG	Congo	KE	Kenya	NL	Netherlands	YU	Yugoslavia
CH	Switzerland	KG	Kyrgyzstan	NO	Norway	ZW	Zimbabwe
CI	Côte d'Ivoire	KP	Democratic People's Republic of Korea	NZ	New Zealand		
CM	Cameroon		Republic of Korea	PL	Poland		
CN	China	KR	Republic of Korea	PT	Portugal		
CU	Cuba	KZ	Kazakstan	RO	Romania		
CZ	Czech Republic	LC	Saint Lucia	RU	Russian Federation		
DE	Germany	LJ	Liechtenstein	SD	Sudan		
DK	Denmark	LK	Sri Lanka	SE	Sweden		
EE	Estonia	LR	Liberia	SG	Singapore		

METHOD FOR IDENTIFYING A USER OF A NETWORKTechnical field of the invention

The invention relates to a method for identifying a user of a network, preferably a wide area network, said network including several clients and several remote
5 servers, wherein at least one remote server is adapted to provide at least one client with a network accessible document in response to a request transmitted by the client to said remote server.

In particular, the invention relates to a method
10 for identifying a user of an Internet client, said client being connected to the Internet and being adapted to receive a hypertext document from a World Wide Web site provided by a remote server.

Background art

When advertising or displaying information on a network, e.g. the Internet, the advertiser or information
15 provider is normally primarily interested in reaching a specific target group. This is a serious drawback for Internet marketing.
20

On the Internet, hypertext documents (e.g. HTTP documents) are linked to each other, constituting a complex structure, referred to as the World Wide Web (WWW). One document can be called a WWW-page, a group of
25 related documents can be called a WWW-site. To access the WWW-pages and sites, clients connected to the Internet are equipped with a hypertext interface, called a browser.

Known methods for advertising on the Internet
30 include displaying smaller pieces of commercial or information as a part of a larger WWW-page. These pieces are called "banners", and can contain graphics, hypertext links etc. Another method is to display a second WWW-page called a "pop-up" in a new browser window. The material

in the banner or pop-up can be related to the contents of the currently visited site, ensuring the provider of the banner or pop-up that the banner or pop-up reaches a certain target group, namely the visitors of the specific site. For example, a WWW-site that contains information about used cars may have a banner that promotes a used-car dealership.

However, the advertiser can only hope to reach a certain user during the time the user visits the WWW-site. Once the user leaves, or if the user never enters the site, it is not possible to expose the user to the advertisement. Nor is it possible to distinguish between users of different age, nationality etc. An American site may well be visited by a user located in Europe, and this user may not be interested in the same banner-promotion that American visitors are.

According to one method, utilized by DoubleClick Inc., information about the user is attained by accessing the users IP (Internet Protocol) address. This address, consisting of a number of digits, e.g. 199.12.345.6, is compared to a database, and information about the user, i.e. country, state and area code, are extracted. This information is used to select banners that match the user. However, the information is not very extensive, and the targeting of advertisements is therefore limited.

One way to ensure a better targeting of information on the Internet is to define a user specific profile for each Internet user, and to communicate this profile to a server, said server being provided with means for accessing pieces of information or other material, e.g. advertisements, and for associating each piece of material with a certain target group. Said server is provided with means for furnishing the material to users having a user profile that corresponds to said target group, without being dependent on the users current whereabouts on the Web. This method is currently utilized by the applicant.

One particular way to accomplish the provision of material from said server to the user is to download it to the client while the client's connection is idle, for example when the user is looking at a previously
5 downloaded WWW-page, and to present it during the time while the client is busy downloading a new WWW-page. One such solution is for example mentioned in the US patent 5,572,643.

This system can preferably be utilized to present
10 the user with a link to a site that he/she is expected to be interested in. This is a way for a WWW-site provider to attract more interesting visitors, and a way for the user to quickly find new, interesting WWW-sites. A drawback with systems of this kind is that although the
15 advertising material is directed towards specific target groups, the sites themselves, that hopefully are visited by the users, cannot be adapted to a specific user. This is especially desirable when the user visits the site as an immediate result of an advertisement presented to the
20 user.

According to prior art, a customization of the material on a WWW-site can be accomplished by the use of "cookies". A cookie is a file that has been stored on a client from a specific site. The user profile can be
25 communicated to the remote server for example through a submitted HTTP-form. The remote server packages the information and returns it to the client in the form of a cookie, which is stored as a file on the client. When the client subsequently requests a WWW-page from the remote
30 server, the cookie file is attached to the request. The remote server processes the request, and can use the information in the attached cookie to customize the document. The WWW-page is then provided to the client.

However, the use of cookies has several limiting
35 factors.

Firstly, a cookie that has been stored on a client from a specific site can only be read back from that

exact site. Therefore, the information in the cookie is site-dependent, and not accessible from another site. As a consequence, a first visit to the site is always necessary in order to create a user profile that the site subsequently can use for customizing the site.

Secondly, cookies are not Internet-user specific, rather operating system specific. In many cases, this means that all users of the same client computer share the same cookies. In some cases, for example if Windows-NT is used, every different user of the operating system can have an individual set of cookies. Still, the cookies are associated with the operating system user. When different users share operating system user ID, the information in the cookies stored on the client will not be able to distinguish between the different users.

Thirdly, once the user has accepted the storage of a cookie on the client, this cookie is generated and appended without the control of the user, and therefore can incorporate information from the user's behavior on the Internet. As a result, a cookie may well identify a client computer in a way that the user does not agree with. A user that one day visits several sites relating to real estate might not actually be interested in real estate. He/she might be doing research for someone else.

Summary of the invention

The present invention provides a solution to the above mentioned problems.

A first object of the present invention is to provide a method for communicating a standardized, user specific profile to a remote server in a network, especially to servers providing WWW-sites on the Internet.

A second object of the present invention is to provide a method for receiving said user specific profile at a remote server, enabling said remote server to use

the information in said user profile, e.g. when providing information on the WWW.

A third object of the present invention is to provide a method for allowing said profile to be defined
5 and updated by the user.

These and other objects are accomplished by a method for identifying a user of a network, such as the Internet, said network including several clients and several remote servers, wherein at least one remote
10 server is adapted to provide at least one client with a network accessible document, such as a hypertext document, in response to a request transmitted by the client to said remote server. The method includes the steps of defining at least one user profile consisting of
15 information about the user, such as age, sex, nationality, language, interests etc., and being provided by the user, storing said at least one predefined user profile in a memory-area of the client, selecting one of said at least one predefined user profile in accordance
20 with the user that is currently using the client for accessing the network, communicating the selected user profile to the remote server, and receiving the selected user profile at the remote server, before said document is provided to the client.

25 By using this method, a server that provides a client with information over e.g. the Internet has access to a user specific profile describing the user that is currently using the client. This enables the server to adapt the contents of for example hypertext documents
30 comprised in a WWW-site in accordance with the user that is currently accessing them.

This presents entirely new means for directing the information on the server towards different groups of people. For example, again referring to a WWW-site
35 marketing a used car dealership, the appearance of the site can be allowed to vary depending on what age, etc., the user has. A young, not married user can be presented

with information about fast, sporty cars, while the middle aged father or mother of three children can be presented with information about stationwagons and so on.

Of course, this is desirable from an advertiser's point of view. A WWW-campaign or a permanent marketing WWW-site will be tremendously more effective when given this possibility to direct the material towards each individual visitor.

At the same time, however, the user also benefits from the system. Each time the user visits a WWW-site applying the method according to the invention, he/she enters a WWW-site adapted to his/hers interests, age or profession. The endless visiting of sites that are not really interesting decreases, and surfing on the Internet becomes more efficient.

According to a first embodiment of the present invention, the profile is communicated to the remote server by appending a character sequence to the request transmission made by the client to the remote server, said character sequence having a predetermined format and representing the selected user profile, in which case the user profile can be received by extracting said character sequence from the request.

In this way, the communication of the profile is achieved with a minimum of effort. The request transmission, which in any case is made to the server in order to receive the WWW-page requested by the client, can be extended to include said character sequence, without causing any noticeable delay.

The request transmission can be initiated by the network interface, e.g. a HTTP-browser, and the character sequence can be appended by means for communicating a user profile, provided in the client.

This facilitates implementing the method on a client that presently communicates with the network with an existing interface.

The character sequence can be encoded by encoding means provided in the client and can be decoded by decoding means in the remote server. This ensures that the information in a user specific profile only is made available to those remote servers that are authorized to access the information.

Further, a key handling server can provide said encoding means and said decoding means with information regarding if and how said character sequence is to be encoded and decoded respectively.

Alternatively, according to a second embodiment of the invention, the profile is communicated to the remote server through a procedure, where the client makes said request to the remote server, the remote server makes a second request, investigating whether a user profile is available at the client and requesting said user profile from the client, and the client responds to the investigation by transmitting the user profile to the remote server.

This procedure is somewhat more complex than the suggested method of attaching a string sequence to the request transmission, but will nevertheless only cause a negligible delay. An advantage is that according to this procedure, the profile is only communicated when the remote server requests it. Many unnecessary transmissions of user profiles are avoided. The conventional request transmission is left unaltered.

Further, as the client in this procedure only communicates the user profile after a reply from the remote server, unauthorized access to profile information may be eliminated. An authorization check may be included in the procedure.

Said user profile can further comprise a user ID, which enables the remote server to attain, from a second remote server, a credit value, representing a number of points available to the user in a point based credit system

Credibility systems according to prior art are site based, meaning that a user can earn and spend point at one specific WWW-site. With the present invention, it is possible to include a point ID in the user specific profile, enabling a remote server to access a the number of points a user has available at a point server. This makes a centralized point system possible, where a user can spend and earn points at different sites.

10 Short description of the drawings

The invention will now be described more in detail, with reference to the drawings, where:

Fig 1 represents an example of an environment in which the method according to the invention is applicable.

Fig 2 is a schematic representation of the advertising server in fig 1.

Fig 3 is a schematic representation of the client in fig 1.

20 Fig 4 is a schematic representation of the remote server in fig 1.

Fig 5 is a schematic representation of how a client, the advertising server, a remote server and a key handling server are connected to each other.

25 Fig 6 is a block diagram illustrating the method according to the invention.

Fig 7 is a block diagram illustrating a first embodiment of a part of the method according to the present invention.

30 Fig 8 shows an example of a request according to prior art.

Fig 9 shows an example of a request according to the invention.

35 Fig 10 is a block diagram illustrating a second embodiment of a part of the method according to the present invention.

Fig 11 is a schematic representation of a point server and a remote server.

Detailed description

5 Fig 1 shows a preferred environment in which the method according to the present invention is applicable. In fig 1, a client 1 is connectable to a remote server 2 in a wide area network over a transmission line 3, using for example TCP/IP. The server 2 provides the client with
10 network accessible documents 4. In the illustrated example, the client is connectable to the remote server 2 via an Internet Service Provider (ISP) 5 connected to the World Wide Web (WWW) 6 and the network accessible documents are hypertext documents 4, stored on the remote
15 server 2. When a user 7 connects the client 1 to the Internet via the ISP 5, an Internet session is commenced, enabling the user to access documents 4 available on the World Wide Web 6.

The client 1 can also be connectable to an
20 advertising server 8. Preferably the advertising server 8 is connected to the Internet, and communication between the client 1 and the advertising server 8 can take place over the Internet. The method according to the present invention is however not limited to the environment in
25 the illustrated example in fig 1.

The client 1 will now be described more in detail, with reference to fig 2.

The client is provided with means 10 for displaying hypertext documents, hereafter called a browser 10. The
30 browser acts as an interface between the user 7 and the WWW 6. When the user clicks on a hypertext link in a hypertext document, previously downloaded to the client, a request transmission 12 is made from the client to the remote server 2 providing the requested document 4.
35 Normally it is the browser 10 that executes this request transmission 12, hereafter referred to as a "request".

Further, the client is provided with means 14 for defining at least one user specific profile 16 and selecting one of said at least one user specific profile 16. A storage means 18, such as a disc, is arranged to store the at least one user profile 16. Said means 14 for defining and selecting said profile 16 can be provided as a software included in the browser 10, or by a separate software, and can be initiated before the Internet connection is established, or at any time during the Internet-session.

The client is further provided with means 20 for communicating the profile to the advertising server 8 and any remote server 2 that provides the client with documents 4. According to a preferred embodiment of the invention, said communication is accomplished when the client requests information from a remote server. Said means 20 for communicating the profile can be incorporated in the browser 10, but may equally well comprise a separate, stand-alone software.

Also provided in the client are encoding means 19, arranged to encode said profile 16 before the profile is communicated to a remote server.

Referring to fig 3, said advertising server 8 contains means 22 for storing a plurality of links 24, pointing to material 26 provided on the WWW by different advertisers, who have defined to what specific target groups they want to expose their material 26. The advertising server 8 is further provided with means 28 for selecting suitable links to furnish to a user, and a WWW-interface 30 for receiving said profile 16 and for transmitting selected links 27 to the user, in order to enable the user to receive advertising material 26 that matches his/her interests, sex, age, etc., as defined in the profile 16.

Said means 22 for storing links can comprise a database 23, storing each link 24 together with an associated array 25 of suitable criteria, describing the

type of user that the material is intended for. Each array 25 of criteria is preferably defined in the same way as the user profile 16, in order to easily establish whether a specific user profile matches the criteria associated with a specific link 24.

Further according to the invention, the remote server 2, shown in fig 4, is provided with means 32 for receiving the user profile, and decoding means 33 for decoding an encoded user profile. These means 32, 33 can be included in a conventional WWW-interface 34 that receives a request 12 from the client and in response to the request furnishes the client with a document 4. However, said means 32, 33 can equally well comprise separate software. In either case, the means 32 may utilize the WWW-interface 34 to communicate information over the Internet.

The function of the above described system will now be discussed.

In order to ensure efficient displaying of advertisements or information to a selected user group the user 7 of the client 1 identifies him-/herself before connecting to the ISP server 2 and commencing the Internet-session. The identification includes defining a profile 16 consisting of any number of specific pieces of information about the user, such as age, sex, interests etc.

As the user 7 connects the client 1 to the Internet, or at any time while the user is connected to the Internet, the user selects a predefined user profile 16 stored on the disc 18, using the software 14. Naturally, the first time a specific user 7 uses the client 1, a new profile is defined using the software 14, and if, at any time, the user wants to change or amend his/her profile, this can also be accomplished using the software 14.

As the user selects a user profile 16, the advertising server 8 is notified that a selection has

been made, and the selected user profile is communicated to the advertising server 8. The means 28 for selecting at least one link 27 performs a comparison of the user profile 16 and the arrays 25 of characteristics that are stored in the database 23. At least one link 27 associated with at least one matching array 25 is then transmitted to the means 30 for sending links to the client 1, and subsequently sent to the client.

The links 24 are preferably hypertext links, pointing to material 26 comprising hypertext documents containing sound, graphics etc., and in particular containing hypertext links to for example the advertiser's WWW-sites.

According to prior art, the material 26 pointed to by the links 27 can be downloaded to the client 1 while the client's Internet connection is idle, thereby not affecting the user's Internet access. Then, while the client is busy accessing new sites on the WWW, the documents pointed to by the links 27 can be displayed on the client.

The material 26 can also comprise graphical material suitable for displaying on the screen of the client 1 as background pictures. These background pictures could for example be downloaded during an Internet session when the user 7 is connected to the internet, and then be displayed on the screen of the client 2 while the client is not connected to the Internet.

According to the method of the invention, said user specific profile 16 is further communicated to any remote server 2, providing the client with documents 4. The complete procedure is illustrated in fig 6.

Of course, the advertising server 8 is not essential to the invention. It is included in the discussion primarily to serve as an example of how the identification method according to the invention can be utilized.

First, in step 40, a user profile is defined by the user. Then, in step 41, the user profile is stored at the client 1. These steps 40, 41 are performed for every user that uses the client 1 to access the Internet. In step 5 42, the user 7 currently using the client 1 selects his/her profile, and this profile 16 is communicated to the remote server 2 in step 43. The remote server 2 receives the profile 16 in step 44, and can adapt 45 the requested document 4 in accordance with the profile 16 10 before the document is provided 46 to the client 1.

According to one preferred embodiment, a block diagram of which is illustrated in fig 7, said steps 43 and 44 of communicating and receiving a user profile are achieved by attaching a character sequence to the request 15 12, made from the client 1 to the remote server 2, and subsequently extracting said sequence from the request.

The request 12 normally has the appearance shown in fig 8. According to the invention, the user profile 16 is attached to the request, for example by adding a line 20 reading "Profile: xxxxxxxxxx" or its equivalence, where each x represents an information carrier, preferably a binary digit (see fig 9). Of course, the exact formulation of this line is not limited to the above stated example. However, it is important that the format 25 is known to the remote server.

The relationship between the information carriers in the user profile and the different qualities of the user, such as age, sex, nationality etc., is not explicitly stated. Additionally, it is not necessary to 30 attach the complete user profile to the request, but instead a smaller abstract may be attached. Information about what information is included in the request is only distributed to authorized servers.

Preferably, the user profile is encoded by encoding 35 means 19 in a suitable way, enabling only the remote servers that have access to decoding means 33 to read the user profile. In this case a key handling server 50

provides the encoding means 19 in the client 1 and the decoding means 33 in the remote server 2 with information 51 regarding if and how the profile is encoded and decoded respectively. This encoding can for example
5 consist of a conventional left or right shift operation of the bits comprising the user profile or user profile abstract.

The procedure for communicating the user profile or user profile abstract to the remote server is shown in
10 fig 7. In step 52 the user profile is left or right shifted. The profile is then attached to the request in step 53 and transmitted to the designated remote server in step 54. These three steps 52, 53, 54 are accomplished by the means 19 and 20 in connection with the browser 10.

15 The remote server receives the request in the conventional way in step 55, and subsequently extracts the profile in steps 56 and 57. The above mentioned means 32 for receiving the user profile are adapted to determine 56 the presence of the user profile in the
20 request and to extract 57 the string sequence from the request. Finally the extracted string sequence is decoded in step 52.

According to an alternative embodiment, the steps
25 43 and 44 of communicating and receiving the user profile comprises the procedure illustrated in fig 10.

When the remote server 2 in step 60 receives a request from the client 1, a reply 63 is immediately transmitted 62 to the client 1, asking for a user profile. This reply 63 needs only be transmitted if the
30 remote server 2 is authorized to access the user profile and if the remote server 2 is interested in the user profile of the user currently requesting a document from the remote server 2. The reply 63 is transmitted from the means 32 for receiving a user profile, possibly using the
35 WWW-interface 34.

In the case a user profile 16 is defined 64 at the client 1, the profile is transmitted 66 to the remote

server. The reply 63 can include instructions to the client, requesting only an abstract of the user profile 16. This way, the remote server 2 only receives the profile information that it has use for. Additionally, 5 the steps 43 and 44 require less time if only a small part of the profile 16 is communicated.

In the case a user profile is not defined 64, e.g. if the client is not provided with the means 14 for defining and selecting a user profile, no profile is 10 transmitted to the remote server 2. Possibly, a message is sent to the remote server indicating this situation, or preferably no action is taken 68. The means 32 receive the transmitted user profile 70.

In either one of the two described embodiments, the 15 key handling server 50 may provide the client with information regarding which remote servers 2 are authorized to read or alter or append the user profiles 16. This can be especially useful if no encoding scheme is utilized.

20 Which parts of the profile 16 that are communicated to the remote server 2 can also be determined by the key handling server 50, or for example the advertising server 8. This ensures a dynamic profile handling method, where the provider of a remote server 2 can choose which parts 25 of a profile that are needed at the remote server 2, and where only these parts are provided to the remote server.

After following the procedure, outlined in figs 7 or 10, the remote server has access to user specific information. This information can be used in any number 30 of ways in order to furnish the user with directed information. The information can also be used for statistical purposes, in order to monitor what groups of users visit a particular WWW-site.

Specifically, a user can be exposed to a hypertext 35 link in one of the pieces of material 26, directed to the user by the advertising server 8. When the user follows

the link, the WWW-page provided to his/her client will be customized.

In a certain embodiment of the present invention, the profile may be constantly updated to include a
5 history of the user's Internet surfing. This history can then be accessed by any remote server authorized to read the profile.

In one use of the present invention, illustrated in fig 11, each user specific profile 16 can include a point
10 ID 80. A point server 82 is connectable to the network, e.g. the Internet, said point server comprising a point database 84, associating a number of points 86 with each ID 80. The remote server 2 in fig 11 provides a WWW-site where point earning and point spending is possible.

15 When a user profile 16 is communicated to a remote server 2 in the previously described way, the point ID 80 is made accessible to the remote server 2. Said point ID can then be used by the remote server to determine the number of points 86 that the specific user has available
20 for spending. This is accomplished by transmitting the point ID 80 to the point server 82. The point server 82 accesses the point database 84, and transmits to the remote server 2 the number of points 86 that are associated with the point ID 80.

25 The number of points can then be altered by a remote server, in accordance with the user's actions on a WWW-site. For instance, the user may be credited a number of points for using links provided to him/her in advertising material. These points can then be used at a
30 different site for any type of service.

It is to be understood that the present invention disclosed herein is not limited to the above described preferred embodiments.

CLAIMS

1. Method for identifying a user of a network, such as the Internet, said network including several clients and several remote servers, wherein at least one remote server is adapted to provide at least one client with a network accessible document, such as a hypertext document, in response to a request transmitted by the client to said remote server, said method including the steps of
- 5
- 10 defining at least one individual user profile consisting of information about the user, such as age, sex, interests etc., and being provided by the user, storing said at least one predefined user profile in a memory means associated with the client,
- 15 selecting one of said at least one predefined user profile in accordance with the user that is currently using the client for accessing the network, communicating the selected user profile to the remote server, thereby giving the remote server access to information about the user before said document is provided to the client.
- 20
2. Method as claimed in claim 1, wherein said user profile is communicated to the remote server by appending a character sequence to the request transmission made by the client to the remote server, said character sequence having a predetermined format and representing the selected user profile.
- 25
3. Method as claimed in claim 2, wherein said request transmission is initiated by a network interface in said client, such as a browser, and wherein the character string is appended to the request transmission by a means for communicating the user profile.
- 30
- 35
4. Method as claimed in claim 2 or 3, wherein

said character sequence is encoded by encoding means provided in the client and said character sequence is decoded by decoding means provided in the remote server.

5

5. Method as claimed in claim 4, wherein a key handling server provides said encoding means and said decoding means with information regarding if and how said character sequence is to be encoded and decoded respectively.

10

6. Method as claimed in any of the preceding claims, further including the step of using said user profile at the remote server for adapting said network accessible document, before said document is provided to the client.

15

7. Method as claimed in any of the preceding claims, wherein said user profile further comprises a user ID, which enables the remote server to access, from a second remote server, the user's credibility in a point based credit system.

20

8. Method as claimed in claim 1, wherein the profile is communicated to the remote server through a procedure, including

25

transmitting said request from the client to the remote server,

30

transmitting a second request from the remote server to the client, requesting a user profile from the client, and

transmitting the user profile from the client to the remote server in response to said second request.

35

9. Method as claimed in claim 8, further including the step of using said user profile at the remote server

for adapting said network accessible document, before said document is provided to the client.

10 10. Method as claimed in claim 8, where said user
5 profile further comprises a user ID, which enables the
remote server to attain, from a second remote server, a
credit value, representing a number of points available
to the user in a point based credit system.

10 11. Method for identifying a user of a network,
such as the Internet, said network including several
clients and several remote servers, wherein at least one
remote server is adapted to provide at least one client
with a network accessible document, such as a hypertext
15 document, in response to a request transmitted by the
client to said remote server, characterized by

 receiving an individual user profile at the remote
server before said document is provided to the client,
said individual user profile having been selected by the
20 user from a plurality of user profiles, stored in a
memory means associated with the client, each user
profile consisting of information about a specific user,
such as age, sex, interests etc.

1/6

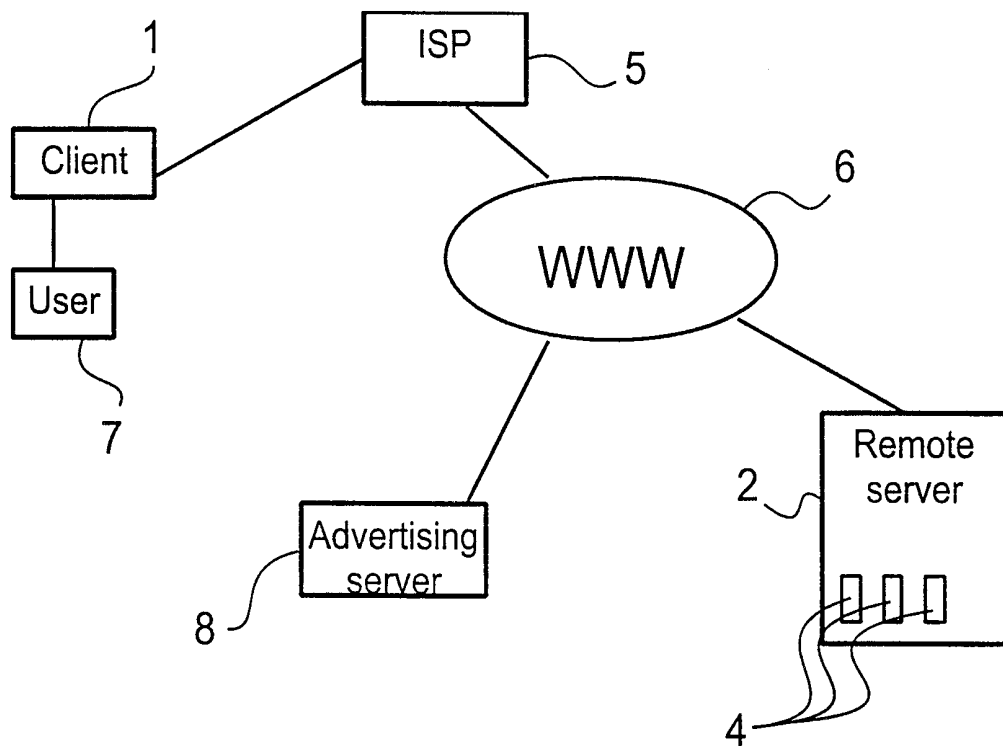

Fig. 1

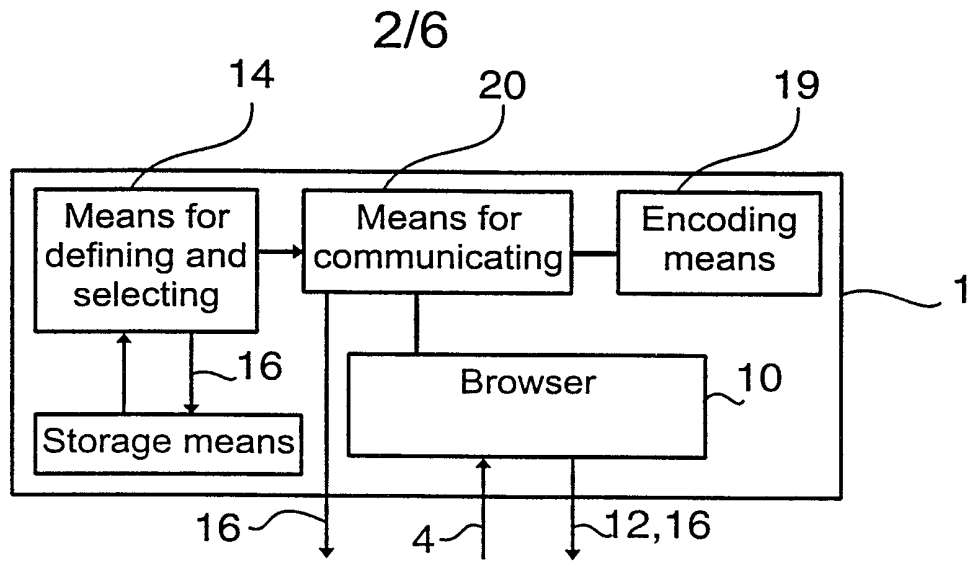

Fig. 2

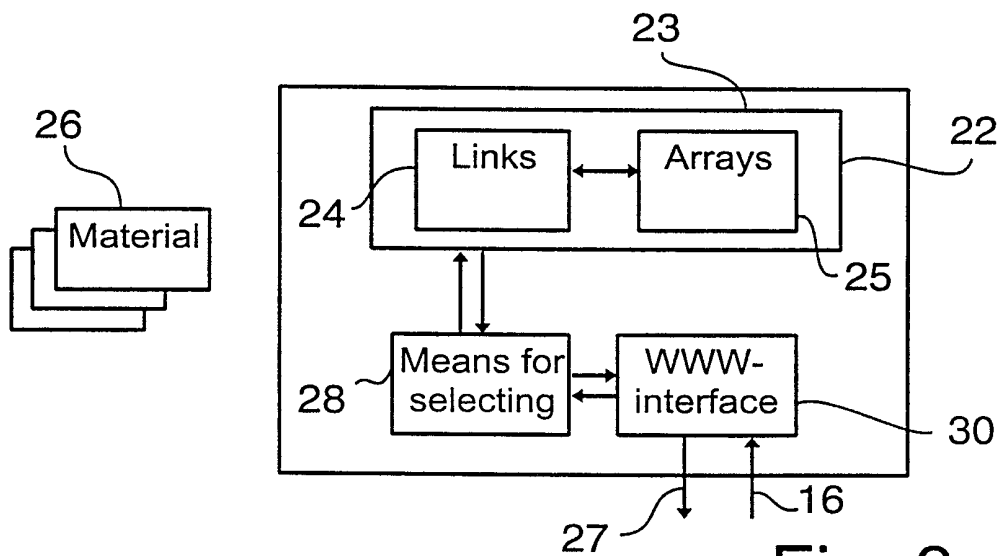

Fig. 3

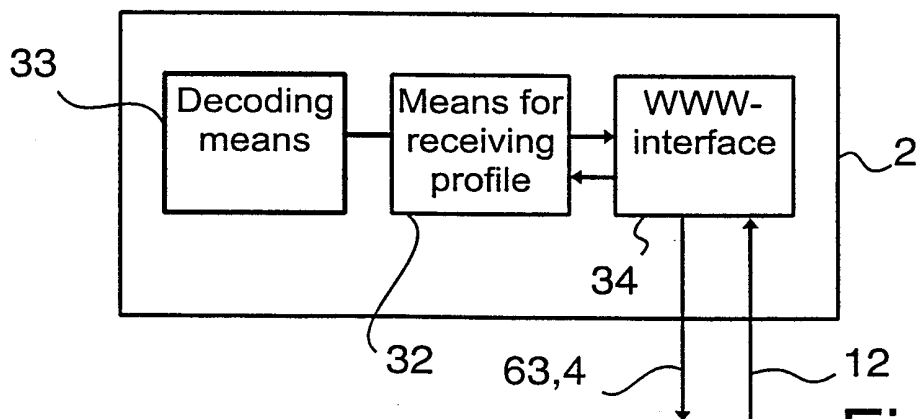

Fig.4

3/6

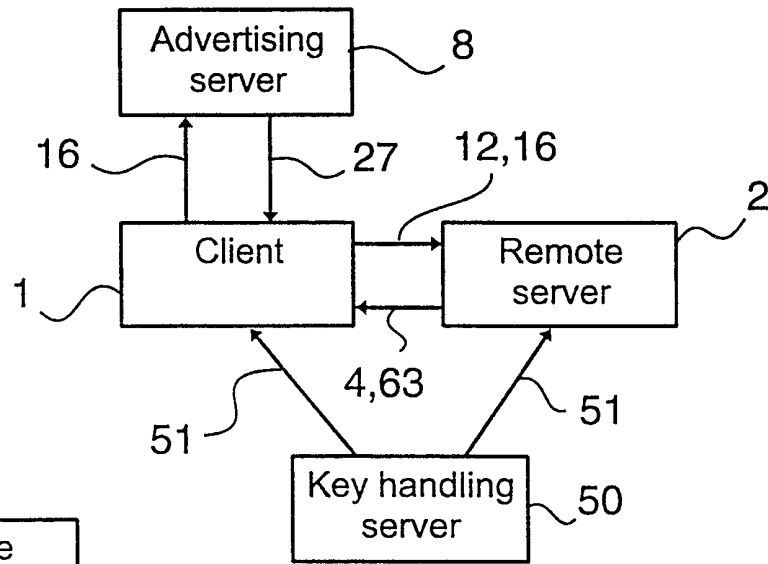

Fig. 5

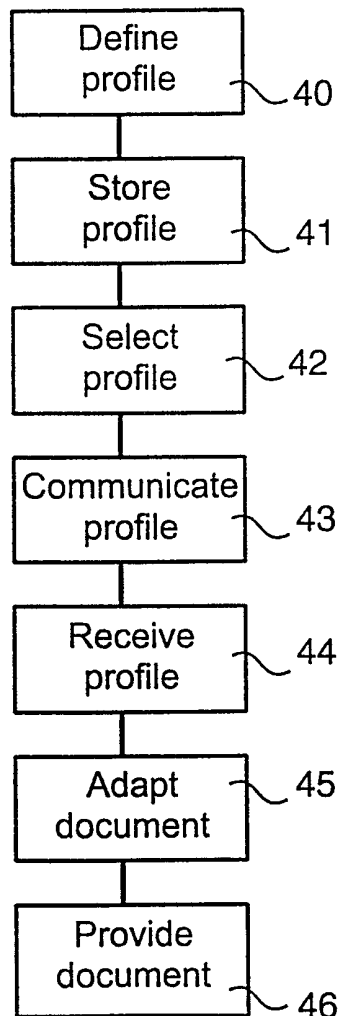

Fig. 6

4/6

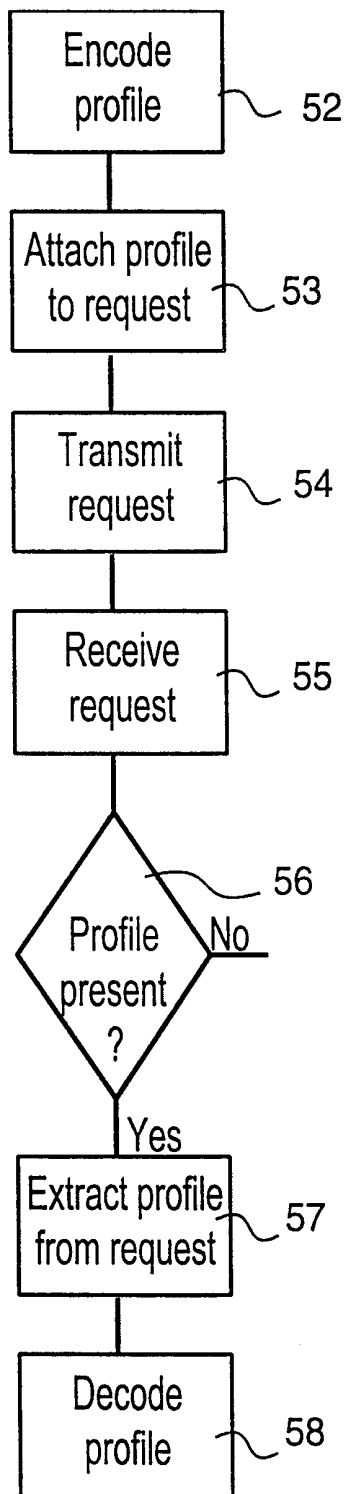

Fig. 7

5/6

```
GET /images/gl/gl52841.gif HTTP/1.0
Accept: */*
Accept-Language: en-us
Accept-Encoding: gzip, deflate
If-Modified-Since: Fri, 15 Apr 1994 00:00:00 GMT; length=1993
User-Agent: Mozilla/4.0 (compatible; MSIE 4.01; Windows NT)
Host: us.yimg.com
Proxy-Connection: Keep-Alive
Pragma: No-Cache
```

Fig. 8

```
GET /images/gl/gl52841.gif HTTP/1.0
Accept: */*
Accept-Language: en-us
Accept-Encoding: gzip, deflate
If-Modified-Since: Fri, 15 Apr 1994 00:00:00 GMT; length=1993
User-Agent: Mozilla/4.0 (compatible; MSIE 4.01; Windows NT)
Host: us.yimg.com
Proxy-Connection: Keep-Alive
Pragma: No-Cache
profile: xxxxxxxxxxxxxxxxxxxxxxxxxxx
```

Fig. 9

6/6

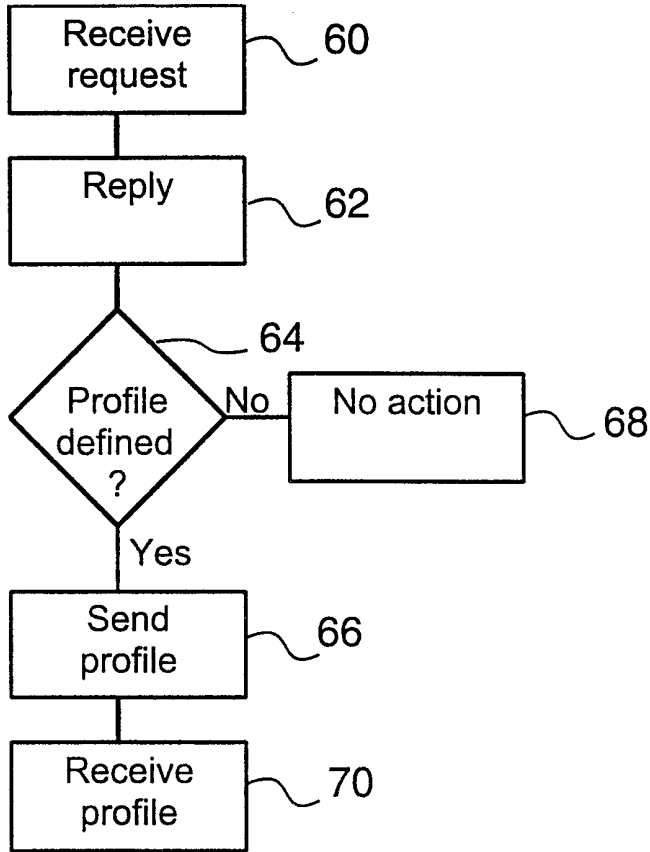

Fig. 10

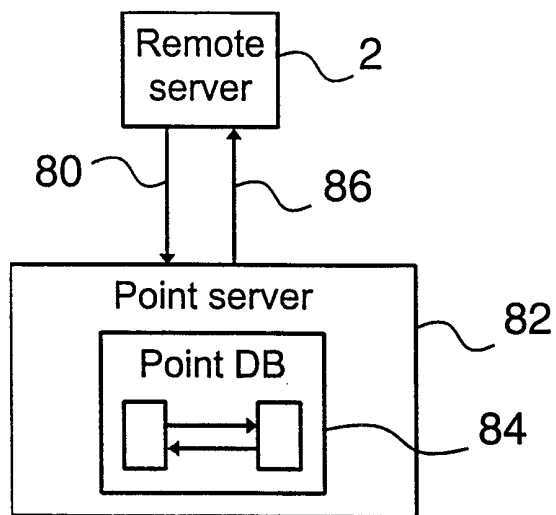

Fig. 11

INTERNATIONAL SEARCH REPORT

International application No.

PCT/SE 99/02058

A. CLASSIFICATION OF SUBJECT MATTER

IPC7: G06F 17/30

According to International Patent Classification (IPC) or to both national classification and IPC

B. FIELDS SEARCHED

Minimum documentation searched (classification system followed by classification symbols)

IPC7: G06F

Documentation searched other than minimum documentation to the extent that such documents are included in the fields searched

SE,DK,FI,NO classes as above

Electronic data base consulted during the international search (name of data base and, where practicable, search terms used)

C. DOCUMENTS CONSIDERED TO BE RELEVANT

Category*	Citation of document, with indication, where appropriate, of the relevant passages	Relevant to claim No.
X	WO 9819224 A2 (OPEN MARKET, INC), 7 May 1998 (07.05.98), page 4, line 16 - line 35; page 12, line 6 - line 19; page 13, line 14 - line 25, page 94, line 22 - page 95, line 11	1-3,6-11
Y	abstract	4,5
	--	
X	US 5740549 A (REILLY, JAMES P. ET AL), 14 April 1998 (14.04.98), column 2, line 41 - line 53; column 3, line 15 - line 24; column 16, line 62 - column 17, line 5	1-3,6-11
Y	abstract	4,5
	--	

 Further documents are listed in the continuation of Box C. See patent family annex.

* Special categories of cited documents:

"A" document defining the general state of the art which is not considered to be of particular relevance

"E" earlier document but published on or after the international filing date

"L" document which may throw doubts on priority claim(s) or which is cited to establish the publication date of another citation or other special reason (as specified)

"O" document referring to an oral disclosure, use, exhibition or other means

"P" document published prior to the international filing date but later than the priority date claimed

"I" later document published after the international filing date or priority date and not in conflict with the application but cited to understand the principle or theory underlying the invention

"X" document of particular relevance: the claimed invention cannot be considered novel or cannot be considered to involve an inventive step when the document is taken alone

"Y" document of particular relevance: the claimed invention cannot be considered to involve an inventive step when the document is combined with one or more other such documents, such combination being obvious to a person skilled in the art

"&" document member of the same patent family

Date of the actual completion of the international search

31 January 2000

Date of mailing of the international search report

25-02-2000

Name and mailing address of the ISA/

Swedish Patent Office
Box 5055, S-102 42 STOCKHOLM
Facsimile No. +46 8 666 02 86

Authorized officer

Jan Silfverling/CL
Telephone No. +46 8 782 25 00

INTERNATIONAL SEARCH REPORT

 International application No.
 PCT/SE 99/02058

C (Continuation). DOCUMENTS CONSIDERED TO BE RELEVANT

Category*	Citation of document, with indication, where appropriate, of the relevant passages	Relevant to claim No.
X	US 5828837 A (EIKELAND, MARTIN), 27 October 1998 (27.10.98), column 2, line 25 - line 53; column 4, line 12 - line 25; column 7, line 61 - column 8, line 30	1-3,6,8,9,11
Y	column 9, line 7 - line 50, abstract --	4,5,7,10
Y	US 5636346 A (SAXE, ANDREW), 3 June 1997 (03.06.97), column 2, line 34 - column 3, line 44, (esp. column 3, line 19-24)	4,5
A	abstract --	1-3,6-11
Y	US 5761648 A (GOLDEN, STEVEN ET AL), 2 June 1998 (02.06.98), column 4, line 40 - line 53; column 7, line 62 - column 8, line 7 --	7,10
X	Patent Abstracts of Japan, abstract of JP 10-134080 A (MAMURA SHIYUNYA), 22 May 1998 (22.05.98), abstract -- -----	1-3,11

INTERNATIONAL SEARCH REPORT

Information on patent family members

02/12/99

International application No.

PCT/SE 99/02058

Patent document cited in search report	Publication date	Patent family member(s)	Publication date
WO 9819224 A2	07/05/98	AU 5240198 A	22/05/98
US 5740549 A	14/04/98	AT 173102 T CA 2177441 A DE 69600905 D,T EP 0749081 A,B JP 9269923 A	15/11/98 13/12/96 17/06/99 18/12/96 14/10/97
US 5828837 A	27/10/98	AU 2311797 A CA 2251175 A CN 1216656 A EP 0894391 A IL 126577 D NO 984684 A US 5768508 A WO 9739548 A	07/11/97 23/10/97 12/05/99 03/02/99 00/00/00 15/12/98 16/06/98 23/10/97
US 5636346 A	03/06/97	NONE	
US 5761648 A	02/06/98	AU 710469 B AU 6762796 A CA 2227876 A CN 1199479 A EP 0845126 A NZ 315832 A WO 9705555 A	23/09/99 26/02/97 13/02/97 18/11/98 03/06/98 28/10/99 13/02/97