

S. R. SMITH & P. P. LANE.
SAWMILL,

No. 22,268.

PATENTED DEC. 7, 1858.
2 SHEETS—SHEET 1.

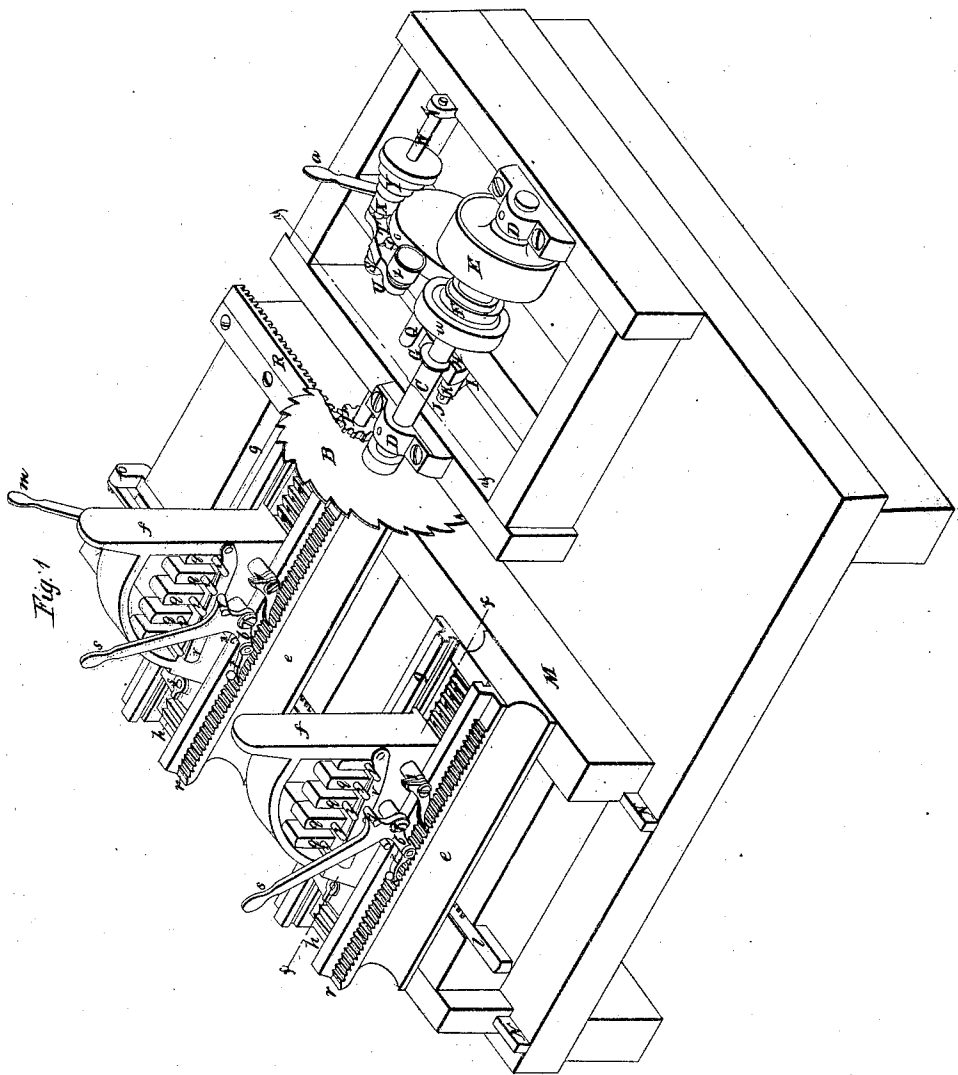

S. R. SMITH & P. P. LANE.
SAWMILL.

No. 22,268.

PATENTED DEC. 7, 1858.
2 SHEETS—SHEET 2.

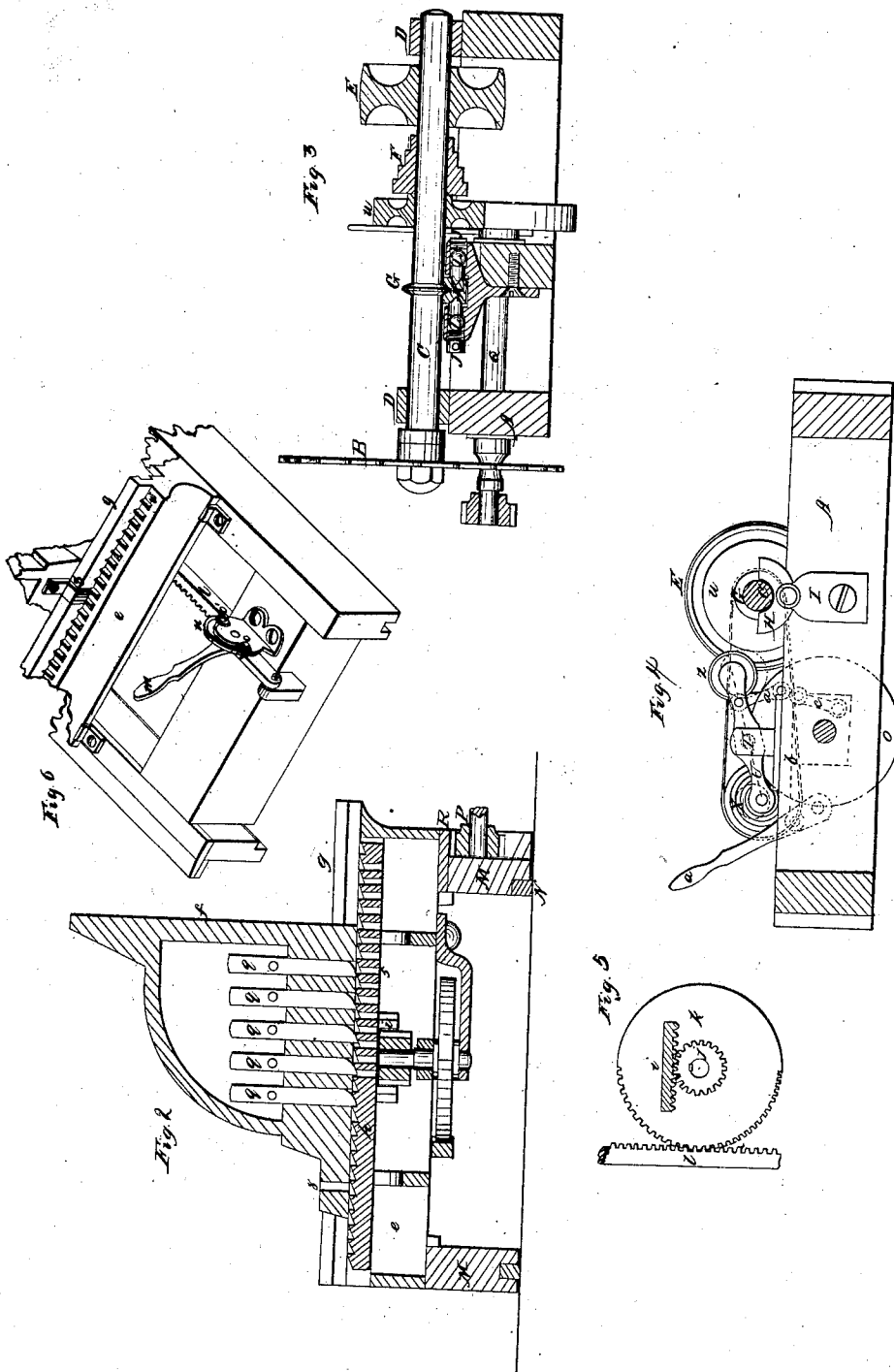

UNITED STATES PATENT OFFICE.

SAML. R. SMITH AND PHILANDER P. LANE, OF CINCINNATI, OHIO, ASSIGNORS TO LANE AND BODLEY, OF SAME PLACE.

SAWMILL.

Specification of Letters Patent No. 22,268, dated December 7, 1858.

To all whom it may concern:

Be it known that we, SAMUEL R. SMITH and PHILANDER P. LANE, both of Cincinnati, Hamilton county, Ohio, have invented
5 new and useful Improvements in Sawmills; and we hereby declare the following to be a full and exact description of the same, reference being had to the accompanying drawings, making part of this specification.

10 This invention relates chiefly to the class known as "portable sawmills," its objects being to increase the compactness and efficiency of such machines and the facility of manipulating them.

15 The improvements consist 1st in an arrangement of "setting" mechanism which admits of the head blocks being placed in effective communication with the setting lever, at any distance asunder without dis-
20 connection of parts; 2nd in an improved arrangement of devices for restraining and regulating the lateral play of a circular saw; 3d in means for preventing the clogging of certain parts of the machinery with sawdust.

25 In the accompanying drawings, Figure 1, is a perspective view of a mill embodying our improvements. Fig. 2, is a vertical section of one of the knees and its accessories at X X Fig. 1. Fig. 3, is a vertical section co-
30 incident with the axis of the saw. Fig. 4 is vertical section at Y Y Fig. 1. Fig. 5, is a diagram representing the relative position and operation of certain parts hereinafter described. Fig. 6 is a detached view of the
35 setting lever and of the index.

A, represents a suitable frame.

40 B is a circular saw whose arbor C is so supported in suitable journal bearings D D as to be capable of end play. Attached to the arbor C are the driving pulley E, a pulley *u*, and a suit of differential pulleys F.

The lateral movement of the saw is regulated by means of the following devices: G is a fast collar on the arbor C, at or near its
45 midlength. The collar G rests in a box H, which box is supported in a bracket or pedestal I attached to the frame. J, are temper screws which pass through lugs K, projecting from the pedestal I. L, are springs of
50 india rubber or other suitable material con-

fining between the box and temper screws and serving in conjunction with the screws J, to regulate the position and play of the box.

M are the timbers of the carriage running
55 on ways N. The feed and gigging back movements of the carriage are communicated from the arbor C as follows: R P Q O are respectively a rack, pinion, shaft and pulley of usual construction. A standard S,
60 rising from the frame A, has projecting horizontally from it, a wrist T, forming the axle of a rocking arm V. V is another standard which affords journal bearing per-
65 mitting the combined rotary and vibratory motion of a shaft W, the other end of said shaft being journaled in one end of the rocking arm U. The shaft W carries a small friction pulley X and a suit of differ-
70 ential pulleys Y, corresponding with those on the arbor C. The other end of the rocking arm U carries a small friction pulley Z which when depressed communicates motion from the pulley *u* to the pulley O. *a b c d* is
75 an arrangement of lever and toggle, connected to the rocking arm U and enabling the operator to place it in either desired position.

The log is "set" or fed laterally toward the saw by means of the following devices: *e e* are head blocks extending transversely
80 across the timbers M of the carriage, and forming support and attachment for the knees *f* and their accessories. *g* are elevated ways, forming on their upper surface a support for the log, and serving to confine the
85 knees to a rectilinear path toward and from the saw. *h* are ratchet racks, perforated (5) to permit the escape of saw dust and having a short longitudinal reciprocating motion imparted to them simultaneously.
90 For this purpose each of the racks *h*, is furnished with a short accessory rack *i*, which gears with a pinion *j*, concentrically attached to a segment wheel *k* which gears into a long rack bar *l*, extending from end
95 end of the casing. The bar *l*, is operated by means of a lever *m*, whose lower end is pivoted to the said bar. *n*, is a segmental guide bar in which the upper part of the lever *m*, works. *o, o*, are stops which being
100

adjusted to any required distance asunder, limit the motion of the lever *m*, to the required extent, to impart the desired lateral feed motion or "set" to the log. The knees *f* are cast with solid heavy bases which are in close proximity to the racks *h*, and have sufficient substance to hold within vertical slots a set of drops *g*, having free vertical play, and so arranged as to come successively into action in customary manner. 2, 2, are lugs projecting laterally from the drops *g*, to enable their simultaneous elevation as hereinafter explained. *p* are a suit of detaining pawls attached to each knee *f* and engaging in an auxiliary rack T, on the head block *e*. The pawls *p*, are constructed with elevated heels (1) for the purpose hereinafter explained. *s*, is a lever of peculiar construction pivoted to each knee *f*, in the manner shown. The lever *s*, has two short arms 6, 7, projecting from opposite sides of it, to one of which (6), a feed hand *t*, is hinged. The arm 7, elevates the pawls *p*, by impinging upon their heels 1, when the lever *s*, is moved in that direction. *v*, is a bar hinged at one end to the knee *f*, and furnished with a lug 3, projecting laterally over the arm 6, of the lever *s*, so as to be elevated by the motion of the latter, which results in the simultaneous elevation of the drops *g*, by means of the bar *v*, engaging under the lugs 2. *W*, is raised scale on the head blocks *e* which in conjunction with a graduated index *y*, on the knee accurately indicates the motion of the latter. 8, are sockets in the knees to receive the shanks of dogs of any customary construction.

The small friction pulley X, we have found to be the most effective when constructed of small disks of leather clamped together. The other friction pulleys are of yellow pine of several thicknesses cross grained and glued and screwed together.

The operation is as follows: The carriage being run back to a proper distance, a log is placed in position upon the ways *g*, of the head blocks, the knees separately moved up to it by means of the levers *s*, and the log confined by dogs in the usual manner. The lever *d*, being then drawn toward the operator in the position shown in the strong lines in the drawings, the feed or forward motion is communicated from the saw arbor through the medium of the differential pulleys F and Y, band 4 shaft W friction pulley X pulley O shaft 2 pinion P and rack R to the carriage M. The cut being completed the lever *a*, is reversed so as to bring the small friction pulley Z, in contact with the pulley W on the arbor and with the pulley O, so as to impart a rapid reverse motion to the carriage, until the log clears the saw, when the lever is suddenly placed in its former position and the opposing friction of the forward motion effects the instantaneous

checking of the carriage in the required position. The lever *a*, is then placed in its middle position so as to leave the carriage at rest and the stops, *o*, *o'* being set the required distance apart the lever *m*, is drawn toward the operator till arrested by the stop *o*, thereby retracting the racks *h*. A forward motion of the lever *m*, against the stop *o'* by advancing the racks *h* sets the knees forward the required distance which is accurately indicated by the scale W and index Z.

The electric cushions L, while permitting the lateral play of the saw, prevent its undue departure and restores it to its normal plane. By adjusting one or both of the temper screws the saw and the arbor may be set bodily out or in or may be allowed a greater or less range of lateral play. Or the temper screws may be made to compress the cushions to such an extent as to render the saw practically speaking rigid and immovable or the cushions may be readily taken out and the temper screws set in so as to render the saw absolutely immovable, a condition which is frequently found desirable. The box H and collar G are placed at such distance behind the front bearing as to hold the arbor firmly against springing and to avoid heating the central portion of the saw.

The feed and gigging back mechanism here described avoids the use of shifting or slack belts and clutches of every description and is prompt and effective in arresting and reversing the rapid motion imparted to the carriage and log in gigging back. Its arrangement is also remarkably simple and compact; qualities of great importance in portable saw mills. By this arrangement also the operator is enabled to "ease the feed" and thus humor the saw by simply graduating the pressure exerted on the lever when a portion of the log is approaching which by reason of a knot or otherwise would be liable to turn the blade of the saw. These movements are effected without any sudden strain or jar of the machinery and have proved of signal value in the working of several machines lately built on our plan. By our method the head blocks or knees may be placed in communication with the setting lever at any distance asunder to accommodate logs of different lengths, and operated separately or simultaneously, without in either case any disconnection of parts.

We claim as new and of our invention herein:

1. The longitudinal rack bar *l*, combined as described with the segment wheel *k*, pinion *j*, and accessory rack *i*, so as to admit of the head blocks being placed in gear at any required distance asunder without disconnection or adjustment of parts.

2. The described arrangement of the collar G, box H, cushions L, and temper screws J, whereby the saw may be fixed rigidly in

any position or allowed lateral play to any desired extent and returned automatically to its normal plane when released and by means of which the position of the said normal plane may be varied at pleasure.

5 3. The perforations 5, applied to the transverse racks p , in the manner and for the purpose explained.

In testimony of which invention we hereunto set our hands.

SAMUEL RUFFUS SMITH.
P. P. LANE.

Attest:

GEO. H. KNIGHT,
C. STEEMER.