

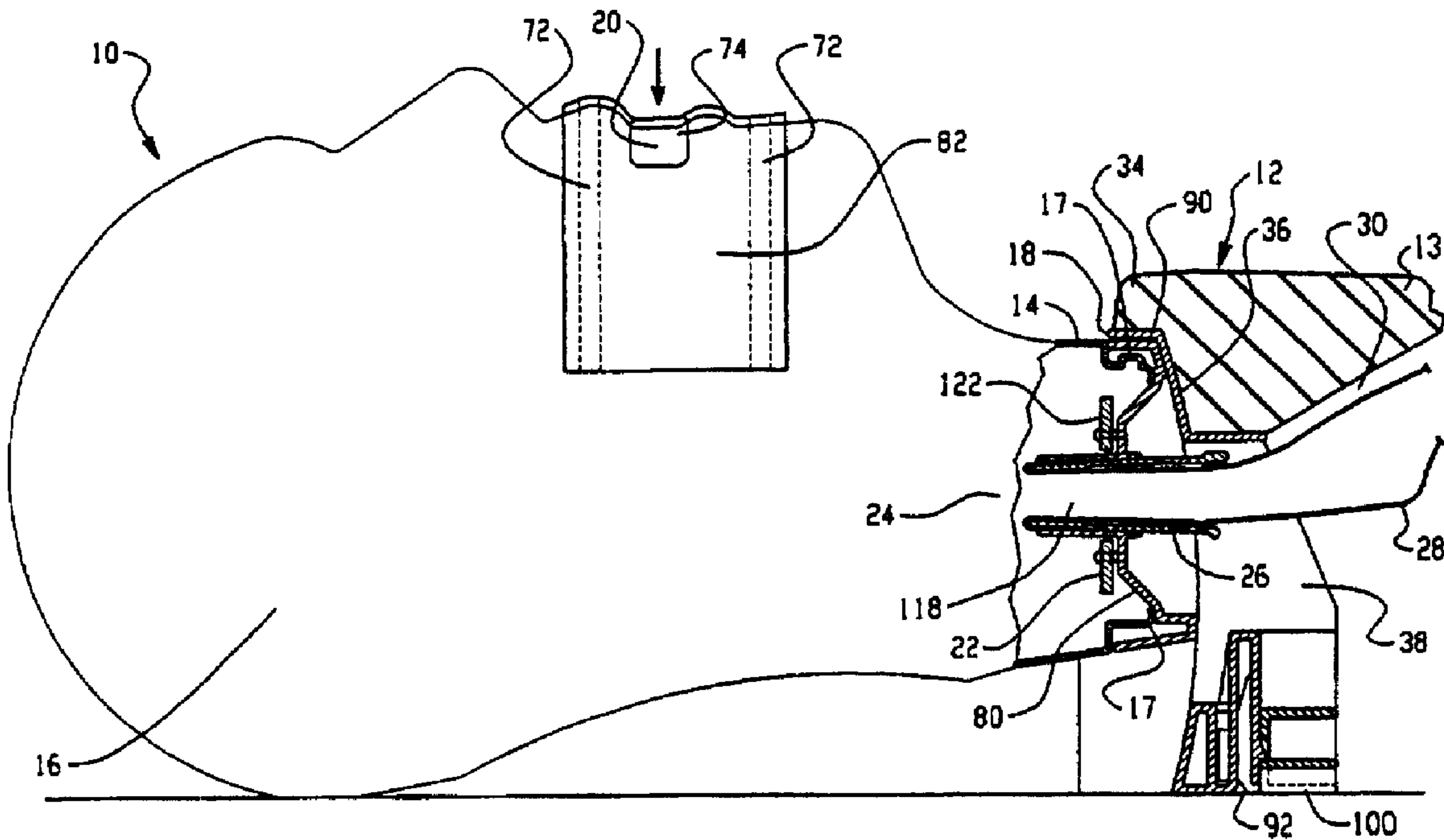

(86) Date de dépôt PCT/PCT Filing Date: 1998/03/12
 (87) Date publication PCT/PCT Publication Date: 1998/09/17
 (45) Date de délivrance/Issue Date: 2007/08/07
 (85) Entrée phase nationale/National Entry: 1999/09/30
 (86) N° demande PCT/PCT Application No.: US 1998/004877
 (87) N° publication PCT/PCT Publication No.: 1998/040864
 (30) Priorité/Priority: 1997/03/12 (US08/820,330)

(51) Cl.Int./Int.Cl. *G09B 23/28* (2006.01)
 (72) Inventeurs/Inventors:
 KOPCO, JAMES J., US;
 LINDSETH, STEVEN W., US;
 NOTTINGHAM, JOHN R., US;
 PASTRICK, JOHN J., US;
 PLANTZ, JEFFREY S., US
 (73) Propriétaire/Owner:
 THE ARISTOTLE CORPORATION, US
 (74) Agent: BORDEN LADNER GERVAIS LLP

(54) Titre : MANNEQUIN POUR PRATIQUER LA REANIMATION CARDIO-RESPIRATOIRE
 (54) Title: CARDIOPULMONARY RESUSCITATION MANIKIN



(57) **Abrégé/Abstract:**

This invention is an adult/child and infant manikin (10) for cardiopulmonary resuscitation including a torso simulation (12) having an arcuate mounting surface, and a head simulation (16) having a neck attachment (14) connected thereto. The neck attachment (14) has an arcuate connection that is congruent to said arcuate mounting surface. Mounting members (80, 90) adapted to secure the head simulation to the torso simulation with the arcuate connection in contact with the arcuate mounting surface are also provided. The mounting members are movable in an arc across the arcuate mounting surface.

CARDIOPULMONARY RESUSCITATION MANIKINFIELD OF THE INVENTION

5 This invention relates to improved manikins for teaching cardiopulmonary resuscitation including ventilation and external heart massage.

BACKGROUND OF THE INVENTION

10 Manikins are often used as an instructional aid in teaching students cardiopulmonary resuscitation techniques. Training manikins are also used as a practice aid to simulate conditions under which rescue personnel may be required to treat injured persons. As both
15 teaching or demonstration aids and practice aids, manikins enable the realistic application of proper emergency cardiopulmonary resuscitation ("CPR") techniques including ventilation and external heart massage. Also manikins can be utilized for teaching and practicing other rescue
20 techniques such as the Heimlich maneuver.

In order to provide effective CPR training through use of a manikin, many complex and interrelated functions and structures of the human body must be simulated so that the training is as realistic as possible. Also, the
25 manikin needs to be safe and hygienic so that multiple persons can learn rescue techniques on a single manikin. The manikin should also be designed so that it can aid in the teaching of pulmonary ventilation or "mouth-to-mouth resuscitation" as well as external heart massage.

30 A moveable head/neck assembly is desirable for ventilation simulation, so that the manikin simulates the opening of the human airway that occurs by tilting back a person's head. Also, realistic torso anatomy is necessary to teach and simulate proper positioning and placement of
35 the hands to properly perform external heart massage, and the Heimlich maneuver. Furthermore, a chest simulation formed of a compressible material is desirable to simulate breathing during ventilation and allow the student to

gauge whether the proper amount of pressure is being exerted to a predetermined depth within the CPR manikin during external heart massage.

5

SUMMARY OF THE INVENTION

In accordance with the present invention, an improved manikin is provided for the instruction and practice of cardiopulmonary resuscitation and other rescue techniques. The manikin is provided in the form of a human torso simulation coupled with a human head simulation. The head simulation is connected to the torso simulation by a neck attachment which allows the head to tilt, mimicking the movement necessary to open a human airway. The invention also provides an inexpensive, portable manikin for use as an instructional aid with CPR training courses, or for home use by individuals desiring to continue their practice of these lifesaving skills. The manikin includes a selector apparatus so that training may be selectively conducted to simulate the different conditions and techniques required to be used either on an adult or a child. Furthermore, the present invention has an infant embodiment for teaching the unique requirements of infant rescue techniques.

The torso simulation is preferably formed from a compressible material, and provides audible and visual feedback during both ventilation or mouth-to-mouth resuscitation and compression or external heart massage. The torso simulation defines an inner cavity and has a shoulder area with an opening therethrough. Disposed within the torso cavity is a lung simulation in the form of a disposable lung bag and an optional compression bellows for use in the adult manikin. The compression bellows includes a clicker apparatus or other such device to provide the trainee with audible feedback during training of CPR. The audible feedback is provided to indicate whether the trainee using CPR manikin is applying sufficient pressure to reach the predetermined depth within the CPR manikin to simulate external heart massage

on a human. Compression to the predetermined depth results from compression of both the compressible material of the torso simulation as well as of the compression bellows, at least in the adult/child manikin. A selector apparatus is preferably provided in the bellows so that the trainee can select either adult or child external heart massage. Also, 5 the chest area of the compressible torso simulation is preferably configured to rise when the lung bag is properly filled with air during ventilation, simulating human breathing, if proper ventilation is performed.

The torso simulation is connected to the head simulation by a neck attachment. The head simulation has a mouth opening and a neck opening which define the ends of 10 an airway that is in communication with the lung bag located within the torso cavity. The neck attachment is designed to provide proper airway access from the head simulation to the lung bag of the torso simulation when the head simulation is tilted into a position which opens the airway. The neck attachment and head simulation tilt in a manner to simulate the movement of an actual human head and neck when a 15 downward force is applied to a person's forehead. In humans, this tilting is necessary in to ensure that the airway is open and unobstructed from the mouth to the lungs. In the simulation manikin of the present invention, tilting is also necessary to open the airway from the mouth through the neck and into the lung bag. If the head simulation is not tilted into its proper position, the airway connecting the head to the lung bag will 20 not open, and the air required to inflate the lung bag cannot be blown into the lung bag, just as the lungs could not be filled in a human.

The present invention provides a new and improved CPR training manikin which is inexpensive, portable, easy to clean for use by multiple users and additionally provides feedback to ensure complete and realistic training.

25 More particularly, one aspect of the invention is to provide a manikin for cardiopulmonary resuscitation comprising:

a torso simulation having an arcuate mounting surface;

a head simulation having a neck attachment connected thereto, said neck attachment having an arcuate connection that is congruent to said arcuate mounting 30 surface; and

mounting members adapted to secure said head simulation to said torso simulation with said arcuate connection in contact with said arcuate mounting surface, said mounting members being movable in an arc across said arcuate mounting surface.

Another aspect of the invention is to provide a manikin for CPR training
5 comprising:

a compressible body simulating at least the chest area and shoulder area of a human torso, with an opening in said shoulder area; and

a mounting member having an arcuate mounting surface positioned adjacent to said shoulder area, with an air opening in said mounting surface and an air conduit
10 extending from said air opening through the opening in said shoulder area.

Another aspect of the invention is to provide a manikin head and neck assembly for mounting upon a torso simulation, the head and neck assembly comprising: a head simulation having a neck simulation connected thereto, said neck simulation having a connecting surface for insertion into a torso mounting surface to allow said connecting
15 surface to move across said mounting surface whereby said head simulation is movable into a typical position for the head of an unconscious human needing CPR ventilation, said torso mounting surface further comprising one or more channels for receiving said connecting surface of said neck simulation.

Another aspect of the invention is to provide a manikin head and neck assembly
20 for mounting upon a torso simulation, the head and neck assembly comprising: a head simulation having a neck simulation connected thereto, said neck simulation having a connecting surface for insertion into a torso mounting surface to allow said connecting surface to move across said mounting surface whereby said head simulation is movable into a typical position for the head of an unconscious human needing CPR ventilation,
25 said connecting surface of said neck simulation further comprising one or more mounting pins.

Another aspect of the invention is to provide a manikin head and neck assembly for mounting upon a torso simulation, the head and neck assembly comprising: a head simulation having a neck simulation connected thereto, said neck simulation having a
30 connecting surface for insertion into a torso mounting surface to allow said connecting surface to move across said mounting surface whereby said head simulation is movable

into a typical position for the head of an unconscious human needing CPR ventilation, said torso simulation further comprising: a bellows having an upper surface and a lower surface; said lower surface having an opening therethrough; a bellows selector rotatably disposed within said lower surface and comprising a handle portion and a column portion; and a clicker apparatus connected to said column portion for providing audible feedback during external heart massage.

Another aspect of the invention is to provide a manikin head and neck assembly for mounting upon a torso simulation having a mounting surface, the head and neck assembly comprising: a head simulation having a neck simulation connected thereto, said neck simulation having a connecting surface slidably mounted within said torso mounting surface wherein said head simulation is movable into a typical position for the head of an unconscious human needing CPR ventilation; said torso simulation further comprising a bellows having an upper surface and a lower surface; said lower surface having an opening therethrough; a bellows selector rotatably disposed within said lower surface and comprising a handle portion and a column portion; and a clicker apparatus connected to said column portion for providing audible feedback during external heart massage.

For a better understanding of the manikin of the present invention and its advantages, reference should be made to the following detailed description of the invention taken

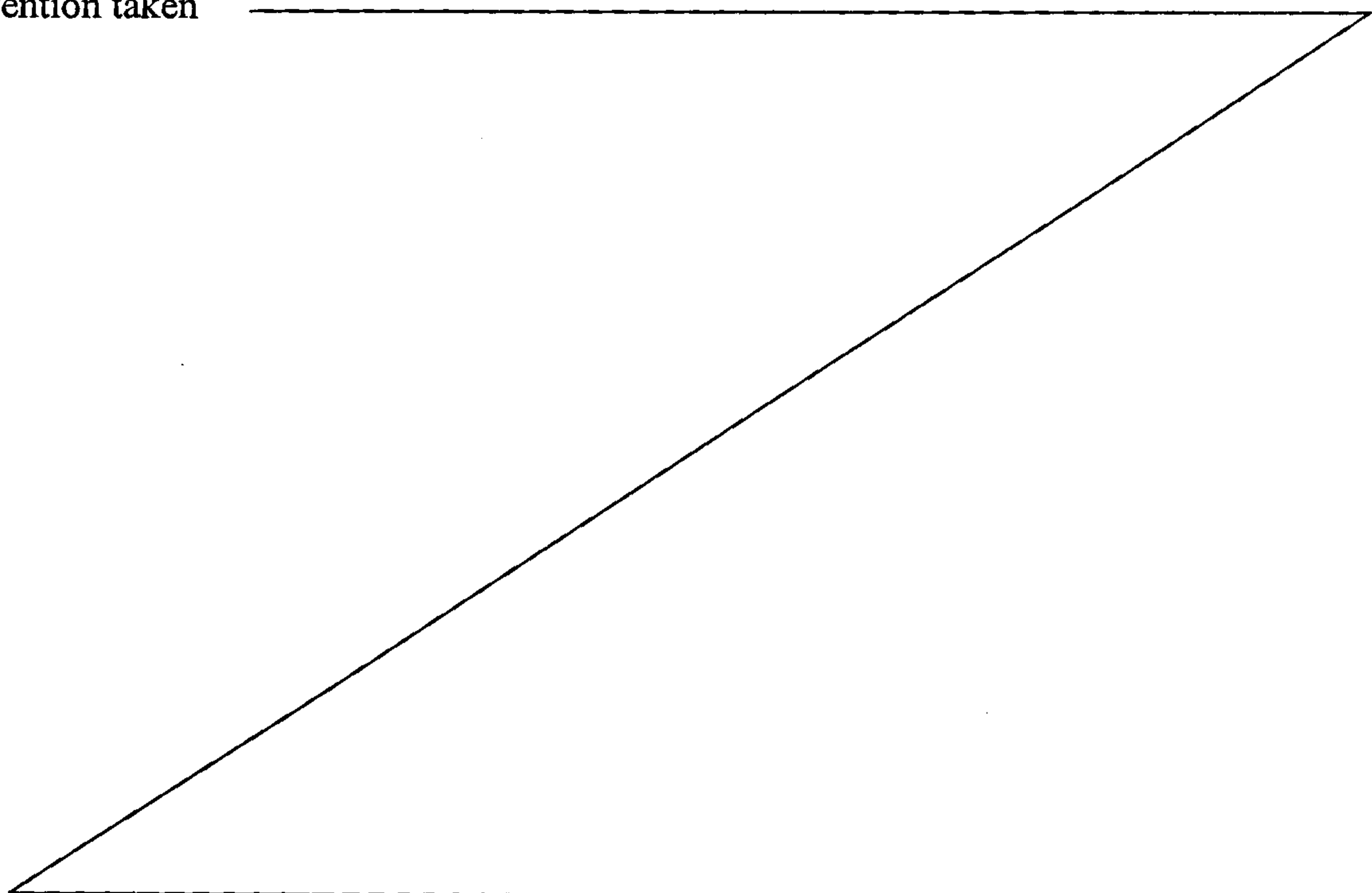

in conjunction with the accompanying drawings. Additionally, other features and advantages the present invention will become apparent from the following detailed description of the preferred embodiments made with
5 reference to the accompanying drawings, which are incorporated in and form a part of the specification.

BRIEF DESCRIPTION OF DRAWINGS

10 Figure 1 illustrates a torso side view of a neck attachment of an adult CPR manikin of the present invention where an airway is in a closed position;

Figure 2 illustrates a head side view of the neck attachment of Figure 1;

15 Figure 3 illustrates the torso side view of the neck attachment of Figure 1, but with the airway in an open position, such that an interconnected head simulation is in a tilted position;

20 Figure 4 illustrates the head side view of the neck attachment of Figure 3;

Figure 5 is a schematic cut-away side view of the head simulation interconnected with the neck attachment, which is interconnected with a torso simulation, with the airway in the open position as shown in Figures 3 and 4;

25 Figure 5A is a schematic cut-away side view of the apparatus of Figure 5, with a filter membrane covering the mouth opening;

30 Figure 5B is a schematic cut-away side view of the apparatus of Figure 5, with an alternate embodiment of the lung bag;

Figure 5C illustrates the filter membrane shown in Figure 5A;

Figure 5D illustrates the alternate embodiment of the lung bag illustrated in Figure 5B;

35 Figure 6 is a schematic cut-away side view of the head simulation interconnected with the neck attachment, which is interconnected with the torso simulation, with the airway in the closed position as shown in Figures 1 and 2;

Figure 7 is a schematic cut-away side view of the interconnected head simulation, neck attachment and torso simulation of Figure 6, with a bellows selector shown in position for simulation of external heart massage on a child;

Figure 8 is a schematic cut-away side view of the interconnected head simulation, neck attachment and torso simulation of Figure 5, with the bellows selector shown in position for simulation external heart massage on a child;

Figure 9 is a schematic cut-away side view of the manikin of Figure 8, but with a lung bag inflated during ventilation;

Figure 10 is a schematic cut-away side view of the manikin of Figure 7, but with the torso simulation compressed during external heart massage;

Figure 11 is a schematic cut-away side view of the interconnected head simulation, neck attachment and torso simulation of Figure 6, with a bellows selector shown in position for simulation of external heart massage on an adult, and with the torso simulation compressed during external heart massage;

Figure 12 illustrates the CPR manikin of the present invention being used to practice external heart massage;

Figure 13 is a torso side view of a mounting member of the neck attachment interconnected with the head simulation of the adult CPR manikin;

Figure 14 is a head side view of a mounting plate of the neck attachment interconnected with the torso simulation of the adult CPR manikin;

Figure 15 is a head side view of a mounting member interconnected with a mounting plate/lung bag retainer of an infant CPR manikin of the present invention where the airway is in a closed position;

Figure 16 is a head side view of the apparatus of Figure 15, but where the airway is in an open position;

Figure 17 is a schematic cut-away side view of the head simulation interconnected with the apparatus illustrated in Figure 15, which is interconnected with the torso simulation, with the airway in the closed position;

Figure 17A is a schematic cut-away side view of the apparatus of Figure 17, with the filter membrane covering the mouth opening;

5 Figure 17B is a schematic cut-away side view of the apparatus of Figure 17, with an alternate embodiment of the lung bag;

Figure 18 is a schematic cut-away side view of the infant manikin of Figure 17, with the airway in the open position;

10 Figure 19 is a schematic cut-away side view of the infant manikin of Figure 17 with the torso simulation;

Figure 20 is a schematic cut-away side view of the infant manikin of Figure 18 with the torso simulation;

15 Figure 21 is a schematic cut-away side view of the infant manikin of Figure 20, but with a lung bag inflated during ventilation;

Figure 22 is a torso side view of a mounting plate of the neck attachment interconnected with the head simulation of the infant CPR manikin; and

20 Figure 23 is a head side view of a mounting plate/lung bag retainer interconnected with a torso simulation of the infant CPR manikin.

DETAILED DESCRIPTION OF THE PRESENT INVENTION

25

The present invention is a manikin apparatus 10, 10' for use as an instructional and practice aid in the teaching and simulating of cardiopulmonary resuscitation. The apparatus is in the form of a manikin resembling portions of a human body. The manikin has a torso simulation 12, 12' a neck attachment 14, 14' and a head simulation 16, 16'. The invention preferably provides both an adult/child embodiment as shown in Figures 1-14 and an infant embodiment as shown in Figures 15-23. It is noted that to the extent features of one embodiment of the apparatus are identical to features in an alternate embodiment of the apparatus, those features may not be discussed further, and are referenced in the figures with a prime designation.

30

35

As shown, both the adult/child embodiment in Figures 1-14 and the infant embodiment in Figures 15-23 have the torso simulation 12, 12' connected to the head simulation 16, 16' by the neck attachment 14, 14'.

5 The neck attachment 14, 14' is constructed to slide within a neck/torso interface 18, 18'. This movement mimics the movement of a human head and neck when a downward force is applied to the forehead. The head simulation 16, 16' has a mouth opening 20, 20' and neck opening 22, 22' that define an airway passage 24, 24', which is illustrated by arrows shown, for example, in Figures 5 and 17. In the preferred embodiment of Figures 5 and 13, the head simulation 16 additionally includes nostril openings 21. During the practice of mouth-to-
10 mouth resuscitation using the adult/child manikin, the nostril openings 21 must be covered by the trainee's fingers F. This procedure is intended to simulate pinching of the nostrils in a human. Since, but for the nostril openings 21 and the mouth opening 20, the head simulation 16 is sealed, the covering of the nostril
15 openings 21 results in airflow to the airway passage 24 from the mouth M of the trainee through the mouth opening 20, as shown in Figure 5.

In the embodiments of the present apparatus, the head simulation 16, 16' is a rigid one-piece, blow molded plastic structure, preferably of polyethylene copolymer material. This material may be readily placed in dishwasher or subjected to other cleaning procedures. However, a variety of alternate materials may be used.

25 The airway passage 24, 24' is in communication with an air piece 26, 26' of the neck attachment 14, 14' to allow air communication between the mouth opening 20, 20' and a lung bag 28, 28' located in a torso cavity 30, 30' within the torso simulation 12, 12'. In the preferred embodiment, the lung bag 28, 28', is illustrated in
30 Figures 5 and 17, is a plastic film material.

In the adult/child embodiment of Figures 1-14, the torso simulation 12 includes the torso cavity 30 housing a compressible bellows unit 32 and the lung bag 28. The

communication of the airway passage 24 and lung bag 28 allow for the teaching and practice of ventilation, while the compressible bellows unit 32 is used for teaching and practice of external heart massage.

5 The torso simulation 12 includes a shoulder area 34, 34' with a torso/neck attachment interface 36, 36'. Furthermore, the torso/neck attachment interface 36, 36' of the shoulder area 34, 34' has an opening 38, 38' therethrough to allow communication between the neck attachment 14, 14' and the torso cavity 30, 30'. An end portion 29 of the lung bag 28, 28' is disposed through the opening 38, 38' to provide the aforementioned communication.

10 The torso simulation 12, 12' is formed from a compressible foam material. In the preferred and illustrated embodiment, the torso simulation is made of a flexible, low density foam polyurethane which is commonly available. Additionally, a resistive coating 40, 40' may be provided to the foam torso simulation to avoid wear, dirt and other substances such as cleaning fluids, as shown in Figures 8 and 20. The flexible, strong resistive coating 40, 40' is preferably added in commercial applications of the manikins 10, 10' where repeated use of the manikin occurs, also requiring frequent cleaning. Such a coating provides durability, as well as resistance to cleaning and cleaning chemicals. The coating maybe a vinyl, urethane, acrylic/latex or other suitable material.

20 The torso simulation 12, 12' is made from a compressible material to allow the realistic instruction of external heart massage and other rescue techniques. The compressible materials allow a student or trainee to exert force upon the chest portion 13 of the torso simulation, as is illustrated in Figure 12, and required in external heart massage. The manikin is designed to resemble the human form in order to provide anatomical markers for proper hand placement by the student during performance of the techniques. For example, the indentation 46 in the chest 13 of the torso simulation represents the contoured location of the xiphoid process

30

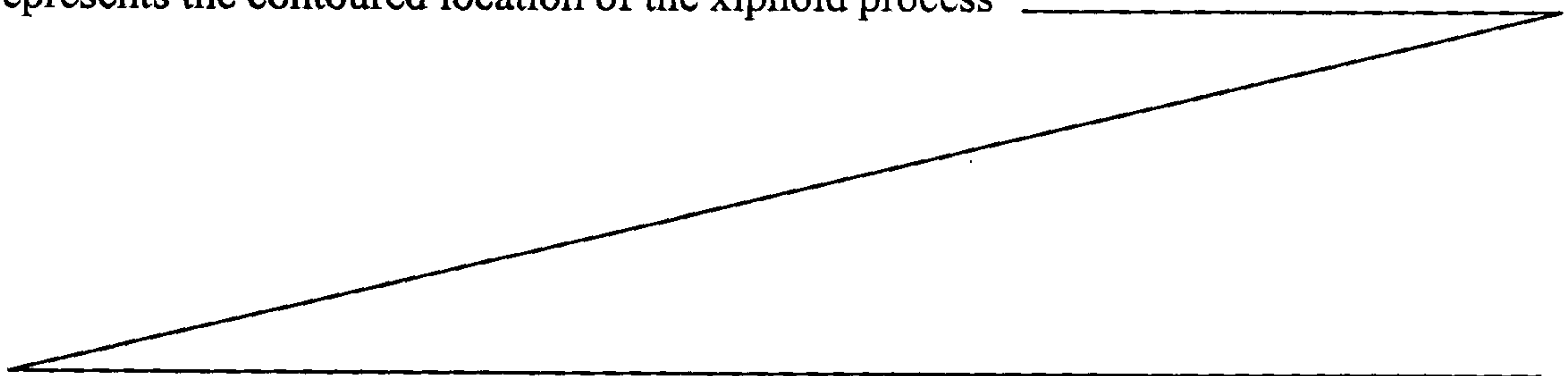

of the sternum, which is to be avoided during external heart massage. These markers are used to teach proper positioning for ventilation, external heart massage and Heimlich maneuver instruction.

5 In the adult/child manikin 10, the torso simulation 12 has a back surface 44 and the external surface 42. The back surface 44 has an opening 48 which extends into the torso cavity 30. An inner surface 50 defines a ceiling of the torso cavity 30. The bellows 32 is positioned within
10 and partially fills the torso cavity 30, with a mouth 52 of the bellows engaged with the opening 48. The diameter of the mouth 52 of the bellows is slightly larger than the diameter of the opening 48, such that the bellows is maintained in position within the cavity 30. The mouth 52
15 of the bellows 32 also engages a selector 54 which is also positioned within the opening 48 of the back surface 44 so that the bellows and selector are positioned in place within the torso cavity 30. The engagement of the selector 54 within the opening 48 of the back surface 44
20 is such that the selector 54 may be rotatable with respect to the bellows 32, which remains in position with respect to the torso cavity 30 during such rotation.

The bellows 32 is preferably a cylindrical configuration. Disposed within the bellows 32 is a
25 clicker apparatus 56, and the mouth 52 of the bellows is engaged within the selector 54. The clicker apparatus 56 is provided to give the CPR trainee audible feedback when the predetermined depth, depending on whether the selector 54 has been moved to the adult or child position, has been
30 reached by application of adequate compression to the torso simulation during external heart massage. The clicker apparatus 56 is preferably a metal bar 58 with a relatively small thickness and some degree of flexibility. One end 60 of the clicker apparatus is attached to or
35 disposed within the bellows so that an unattached end 62, opposite the one end 60, is positioned as illustrated in Figure 10. As seen in Figure 10, a clicker pin 64 is attached to and extends from an inner surface 66 of the bellows 32.

As stated above, the selector 54 is rotatably mounted with the mouth 52 of the bellows and includes a handle portion 68 and a selector column 70. The selector is manually rotated using the handle portion 68. The selector 54 can be set in one of two positions. In the first position, for simulating child CPR, the bellows selector is set so that during external heart massage, if the chest of the torso simulation is properly compressed, the clicker pin 64 will deflect the clicker to provide the trainee with audible feedback that external heart massage was correctly performed. In the second position, for simulating adult CPR, the bellows selector is rotated so that when the chest of the torso simulation is compressed, the clicker pin does not engage the clicker. Thus, less compression is required to engage the clicker with the pin than is required to engage the clicker pin with the inner surface 66 of the bellows 32. Accordingly, the selector is positioned so that the metal bar 58 engages the pin 64 to simulate less compression for heart massage performed on a child. In the preferred embodiment, this is a depth of approximately 1 to 1.5 inches. When adult CPR is desired, the selector 54 is positioned such that the inner surface 66 of the bellows engages the clicker apparatus 66. In the preferred embodiment, this is a depth of approximately 1.5 to 2 inches.

As mentioned above, disposed within the torso cavity 30, 30' is a disposable lung bag 28, 28'. In the embodiments of Figures 5, 5A, 6-11, 17, 17A, and 18-21, the lung bag 28, 28' is designed to be connected to the air piece 26, 26' of the neck attachment 14, and is contained within the torso cavity 30, 30'. In the adult manikin, the lung bag 28 rests on top of the bellows 32.

In a second embodiment, shown in Figures 5B and 17B, the lung bag 28, 28', as illustrated in Figure 5D, passes through the mouth opening 20, 20' and the air piece 26, 26' within the neck attachment and is contained within the torso cavity 30, 30'. The illustrated lung bag 28, 28' has an adhesive area 70 at its open end 29. The open end 29 of the lung bag is pulled or inserted through the

30

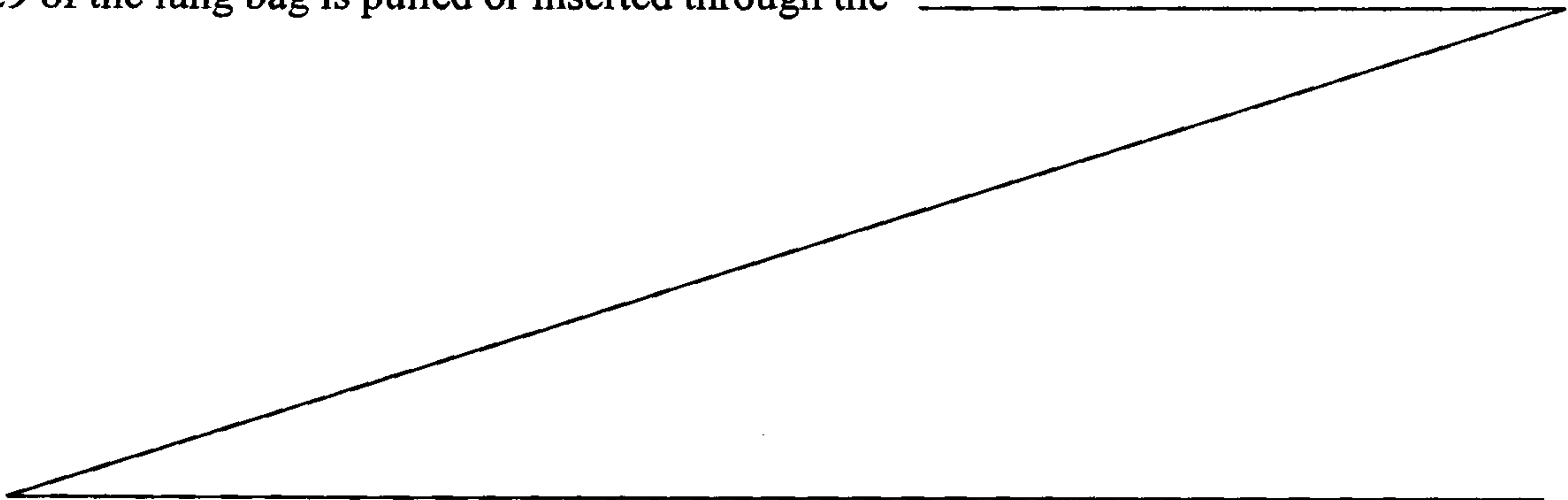

mouth opening of the head simulation 16, 16' so that the adhesive area 70 of the lung bag may be adhered to an external surface of a lip area 74, 74' surrounding the mouth opening 20, 20' of the head simulation 16, 16'. The lung bag is then placed through the neck opening 22, 22' and into the neck attachment 14, 14' passing through the air piece 26, 26', and an opening 78 in a mounting member 80 so that the lung bag is disposed within the torso cavity. It is contemplated that this apparatus will be used in classroom type training scenarios where only a single manikin is available for an entire class, so for health reasons, each pupil will have their own disposable lung bag.

In a still further third embodiment, illustrated in Figures 5A and 17A, a lung bag as described in connection with the first embodiment is used, however, in addition, a mask 82 to cover the mouth opening 20, 20' of the head simulation is provided. As shown in Figure 5C, the mask 82 has a filter media 84 through which air may pass, but which will resist contaminant flow. Additionally, the mask has an adhesive area 72' as illustrated to secure the mask 82 in position on the head simulation. In this embodiment, each student in a class would have their own mask.

During ventilation practice and training, if the trainee properly fills the lung bag 28, 28' with air, the lung bag will expand and press against the torso simulation 12, 12' thereby forcing the simulation upward, as shown in Figures 9 and 21. If the trainee performs proper ventilation, the manikin will appear to "breathe." Thus, by appearing to breathe, the manikin provides visual feedback to the trainee.

The shoulder area 34, 34' of the torso simulation is configured with a neck attachment receiving area 86, 86'. The neck attachment receiving area has an airway opening 88, 88' therethrough to provide communication between the mouth opening of the head simulation and the lung bag once the head simulation, neck attachment and torso simulation are interconnected. The neck attachment receiving area

86, 86' is configured to allow the neck attachment 14, 14' to be connected to the torso simulation.

Referring to Figs. 1-5B, the neck attachment of the adult manikin can be seen. The neck attachment 14 interconnects the torso simulation 12 with the head simulation
5 16. This interconnection enables the airway passage 24 to be opened and closed so that communication is established from the mouth opening of the head simulation through the airway passage and neck attachment to the lung bag. The neck attachment 14 includes a mounting plate 90 with a stop 92, a slideable mounting member and the removable air piece.

10 In a preferred embodiment, the mounting plate 90 of the neck attachment, as best seen in Figures 1, 3, 5 and 6-11, has two opposing flange members 98 and a base flange 100. These flanges are insertable into corresponding flange receiving slots 90 of the neck torso interface of the shoulder area of the torso simulation. Each flange is inserted into its respective flange receiving slot 90 within the torso simulation, and,
15 using an adhesive, the mounting plate may be permanently affixed to the torso simulation, as illustrated.

As can be best seen in Figs. 1, 3 and 5, the mounting plate 90 has two arcuate channels 102 into which mounting pins 104 located on the mounting member 80 are inserted. Each of the opposing flange members 98 includes walls 106 defining surfaces
20 of the arcuate channels 102 and a shoulder 108 defining each channel. The shoulder 108 is shorter than the wall to facilitate movement of the pins 104 into and out of the arcuate channels 102. Also, a ramp 110 allows easy insertion of the pins into their respective channels. As shown, each shoulder 108 has an inner surface at substantially a right angle to the bottom of said channel to inhibit inadvertent movement of the pins
25 out of the channel. Once the mounting pins are inserted into the corresponding arcuate channels of the mounting plate, the mounting member is then slideable within the arcuate channels. The pins are contained within the channels as they rest against the walls 106.

As best seen in Figs. 1-4, the mounting member opening 78 receives the air
30 piece 26. The air piece 26 has an upper lip surface 112, a lung bag engaging surface 114 and a central opening 116 therethrough. In a preferred embodiment, an opening

118 of the disposable lung bag is designed to be inserted through an opening 91 in the mounting plate 90, mounting member opening 78 and central opening 116 in the air piece, and then to slide over the lung bag engaging surface 114 and be folded over upon itself to secure the bag in place. In the embodiment of Figures 5B and 17B, the lung bag is merely inserted through the air piece.

Once the lung bag 28 is in place in the air piece 26, the mounting pins 104 are inserted into their respective arcuate channels 102. To secure the mounting pins in the channels, a stop 92 is inserted into the mounting member. When the airway passage is in the closed position, as seen in Figures 6-7, the upper lip surface 112 rests against the stop 92. Thus, the mounting member may slide upwardly from the stop 92 to the arcuate channels 102. The mounting member 80 also has fixation tabs 120. These tabs 120 engage tabs 17 on the head simulation 16 to attach the mounting member to the head simulation.

Figures 3-5 demonstrate the effect of tilting the manikin head simulation in order to open the airway passage or the respiratory tract, while Figures 1, 2, 6 and 7 illustrate the closed position. As seen in the Figure 6 closed position, a flat portion of the manikin head is resting on a surface. When placed on a surface, the head simulation and neck attachment move under the weight of the head simulation, together with a metal weight or washer 122, 122', and gravity to the closed position of Figure 6, where the air piece 26 is forced in a downward direction with the upper lip surface 112 of the air piece resting upon the removable stop 92. The mounting plate has a pivot or focal point located in a central portion of the head simulation, so that when the head simulation and torso simulation are

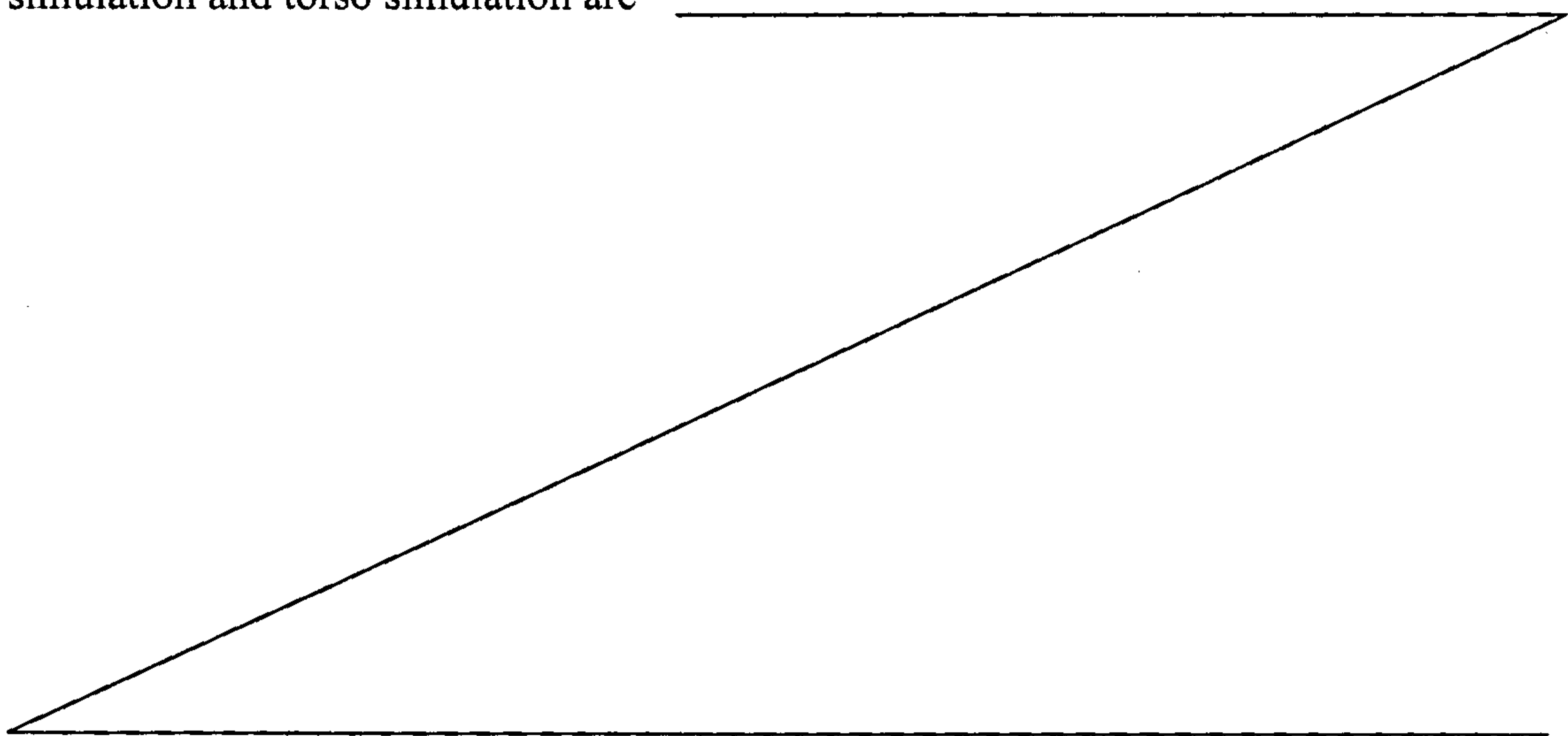

both attached to the neck attachment, the head simulation and neck attachment pivot about the focal point when the mounting plate is moved with respect to the mounting member.

5 As seen in Figs. 3, 4, 5 and 8, when the CPR trainee tilts the manikin head simulation, the mounting member slides in an upward direction through the arcuate channels, thus aligning the air piece central opening 116 with the head simulation and thus opening the lung bag 28.
10 With the air passageway and lung bag now in an open position, the CPR trainee can begin proper ventilation which, if done properly, will result in the visual feedback as mentioned above, and shown in Figure 9. When the head simulation is not tilted into the proper open
15 position enabling ventilation, the upper lip surface of the air piece rests on the removable stop 92, as shown in Figures 1, 2 and 6. In this closed position, air flow along the airway passage 24 from the manikin mouth opening 20 through the neck attachment 14 to the lung bag 28 is
20 restricted, and proper ventilation is not possible.

Figs. 15-23 illustrate the infant embodiment of the improved CPR manikin of the present invention. Like the adult/child manikin, the infant manikin is designed for proper instruction of the ventilation and external heart
25 massage techniques required for resuscitation of an infant. The infant embodiment may also be used to teach other rescue techniques. Also, as in the adult/child manikin, the infant manikin provides feedback to the CPR trainee to indicate if CPR is being properly performed.

30 The differences between the adult/child CPR manikin and the infant CPR manikin will now be discussed. The torso simulation 12' contains a torso cavity 30' that is accessed through a foam torso flap 124. A mounting plate/lung bag retainer 126 is disposed within the torso
35 cavity 30'. The retainer 126 is secured within the torso cavity via adhesive. As seen in Figures 19-21, the mounting plate/lung bag retainer 126 is engaged with a rigid, removable, hinged lung bag bracket member 128 for securing the lung bag in place. The lung bag bracket

member 128 is secured to the foam torso flap 124 via adhesive, such that they may be installed or removed as a unit when the bracket is engaged or disengaged at its non-hinged end 129 from the mounting plate/lung bag retainer as illustrated. When the bracket is removed, the lung bag 28' is placed on top of the mounting plate/lung bag retainer and the lung bag bracket member 128 is then pushed down for re-engagement while holding the lung bag and mounting member in place.

10 The mounting member 80', secured to the head simulation 16', operates substantially as in the adult manikin to receive a lung bag 28' and opposing mounting pins 104'. The mounting pins 104' are inserted into the mounting member. The lung bag bracket 128 is then engaged
15 in place to define the arcuate channels 102'. When the lung bag bracket 128 is placed in position, a wall is formed for each respective channel so that the pins slide within their respective channels while being contained therein. Also, the lower portion of the mounting
20 plate/lung bag retainer has a stop 92.

The air piece 26', as with the adult/child manikin has a lung bag engaging surface 114', an upper lip 112', and a central opening 116' therethrough. Once the pins 104' are contained within the arcuate channels 102', the
25 mounting member 80' is slidable, with its downward range of motion limited by the upper lip of the air piece engaging and resting on the stop 92'. The upper range of motion is limited by the termination of arcuate channels at the lung bag bracket 128. The mounting member 80' is
30 attachable to the head simulation using tabs as in the adult/child manikin. It is also contemplated that the neck attachment may also be connected to the head simulation by conventional means such screws, pins or adhesive.

35 Once the lung bag 28' is situated within the torso cavity 30' and the torso flap 124 and bracket 128 have been replaced, the infant manikin is ready for use. As with the adult manikin, the trainee blows air into the head simulation to produce ventilation. If ventilation is

performed properly, the chest of ~~the~~ ~~linear~~ ~~manipulator~~ ~~will~~ ~~rise~~ rise, thus providing visual feedback to the trainees, as shown in Figure 21.

5 While there have been shown and described what are considered the preferred embodiments of the invention, it will be obvious to one skilled in the art that various changes and modifications may be made therein without departing from the scope of the invention as defined by the claims.

Claims

We claim:

1. A manikin for cardiopulmonary resuscitation comprising:

5 a torso simulation having an arcuate mounting surface;

a head simulation having a neck attachment connected thereto, said neck attachment having an arcuate connection that is congruent to said arcuate mounting surface; and

10 mounting members adapted to secure said head simulation to said torso simulation with said arcuate connection in contact with said arcuate mounting surface, said mounting members being movable in an arc across said arcuate mounting surface.

15

2. A manikin according to claim 1, further comprising:

an air flow opening;

20 an air conduit extending from said neck attachment into said opening;

a bag supported by said air conduit and extending through said air flow opening into said torso simulation;

25 said air conduit being positioned and adapted to press said bag against said torso simulation and close said bag when said neck attachment moves downward and simulates a typical tilted position for the head of an unconscious human needing CPR ventilation.

30 3. A manikin according to claim 2 wherein said bag is a lung simulation disposed within said torso simulation.

35 4. A manikin according to claim 3 wherein said bag extends through an opening in said head simulation, and includes adhesive to secure said bag to said head simulation.

5. A manikin according to claim 1, further comprising an air opening in said arcuate mounting surface

and another air opening in said arcuate connecting surface, wherein said air openings are positioned so that they are in registry when the neck attachment is moved upward to simulate a recommended tilted position for a human head during CPR ventilation.

5 6. A manikin according to claim 1, wherein said mounting members comprise:

 flanges attached to said torso, said flanges defining arcuate channels; and

 pins extending from said neck attachment, said pins being
10 adapted to move in said arcuate channels.

 7. A manikin according to claim 6, wherein said arcuate channel has a closed front end and an open rear end to permit insertion of said pins into said channels.

 8. A manikin according to claim 7, further comprising a stop
15 that can be connected to said mounting plate and limit movement of said head simulation towards the rear of said manikin.

 9. A manikin according to claim 8, wherein said mounting plate comprises connection tabs for holding said stop in position, and said plug comprises an upper surface for limiting movement of
20 said air conduit.

 10. A manikin according to claim 6 wherein said flanges comprise walls defining lateral surfaces of said arcuate channels and a shoulder defining an end of each arcuate channel, said shoulders being shorter than said walls to facilitate movement of
25 said pins into and out of said arcuate channels.

 11. A manikin according to claim 10 comprising a ramp leading to an outer surface of said flange to facilitate movement of said pins into said arcuate channels.

12. A manikin according to claim 11 wherein each of said channels has a shoulder with an inner surface at substantially a right angle to the bottom of said channel to inhibit inadvertent movement of said pins out of said arcuate channels.

13. A manikin according to claim 1 wherein:

said arcuate connecting surface has a focal point in the central portion of said head simulation; and

whereby said head simulation and said neck attachment pivot about said focal point when said connecting surface is moved across said mounting surface.

14. A manikin according to claim 13 wherein the focal point is at or near a rear surface of said head, whereby movement of said rear surface with respect to a supporting surface when said head simulation pivots is minimized.

15. A manikin according to claim 1 wherein said torso simulation is made of compressible foam.

16. A manikin for CPR training comprising:

a compressible body simulating at least the chest area and shoulder area of a human torso, with an opening in said shoulder area; and

a mounting member having an arcuate mounting surface positioned adjacent to said shoulder area, with an air opening in said mounting surface and an air conduit extending from said air opening through the opening in said shoulder area.

17. A manikin according to claim 16 wherein said opening in said shoulder area extends through a wall of said body of compressible material into a central cavity within said body, and said conduit comprises:

a mounting section having an outer diameter substantially equal to the diameter of said opening; and

a flange adjacent to said mounting section, said flange having a diameter greater than said opening;

whereby said flange secures said conduit within said opening and secures said mounting member on said shoulder area.

18. A manikin according to claim 17 wherein said conduit has a lung simulation attachment section adjacent to said flange.

19. A manikin according to claim 16 further comprising a head simulation having a neck simulation extending therefrom;

said neck simulation having an arcuate connecting surface that is congruent to said arcuate mounting surface, said connecting surface having an air opening therein,

mounting members adapted to secure said head simulation to said torso simulation with said arcuate connecting surface in contact with said arcuate mounting surface, said mounting members being further adapted to allow said connecting surface to move in an arc across said mounting surface to move said air opening in the neck simulation into registry and out of registry with said air opening in the torso simulation.

20. A manikin head and neck assembly for mounting upon a torso simulation, the head and neck assembly comprising: a head simulation having a neck simulation connected thereto, said neck simulation having a connecting surface for insertion into a torso mounting surface to allow said connecting surface to move across said mounting surface whereby said head simulation is movable into a typical position for the head of an unconscious human needing CPR ventilation, said torso mounting surface further comprising one or more channels for receiving said connecting surface of said neck simulation.

21. The assembly of claim 20 wherein said channels have an angled shape.

22. The assembly of claim 20 wherein said channels are arcuate shaped.

23. A manikin head and neck assembly for mounting upon a torso simulation, the head and neck assembly comprising: a head simulation having a neck simulation connected thereto, said neck simulation having a connecting surface for insertion into a torso mounting surface to allow said connecting surface to move across said mounting surface whereby said head simulation is movable into a typical position for the head of an unconscious human needing CPR ventilation, said connecting surface of said neck simulation further comprising one or more mounting pins.

24. A manikin head and neck assembly for mounting upon a torso simulation, the head and neck assembly comprising: a head simulation having a neck simulation connected thereto, said neck simulation having a connecting surface for insertion into a torso mounting surface to allow said connecting surface to move across said mounting surface whereby said head simulation is movable into a typical position for the head of an unconscious human needing CPR ventilation, said torso simulation further comprising: a bellows having an upper surface and a lower surface; said lower surface having an opening therethrough; a bellows selector rotatably disposed within said lower surface and comprising a handle portion and a column portion; and a clicker apparatus connected to said column portion for providing audible feedback during external heart massage.

25. A manikin head and neck assembly for mounting upon a torso simulation having a mounting surface, the head and neck assembly comprising: a head simulation having a neck simulation connected thereto, said neck simulation having a connecting surface slidably mounted within said torso mounting surface wherein said head simulation is movable into a typical position for the head of an unconscious human needing CPR ventilation; said torso simulation further comprising a bellows having an upper surface and a lower surface; said lower surface having an opening therethrough; a bellows selector rotatably disposed within said lower surface and comprising a handle portion and a column portion; and a clicker apparatus connected to said column portion for providing audible feedback during external heart massage.

1/25

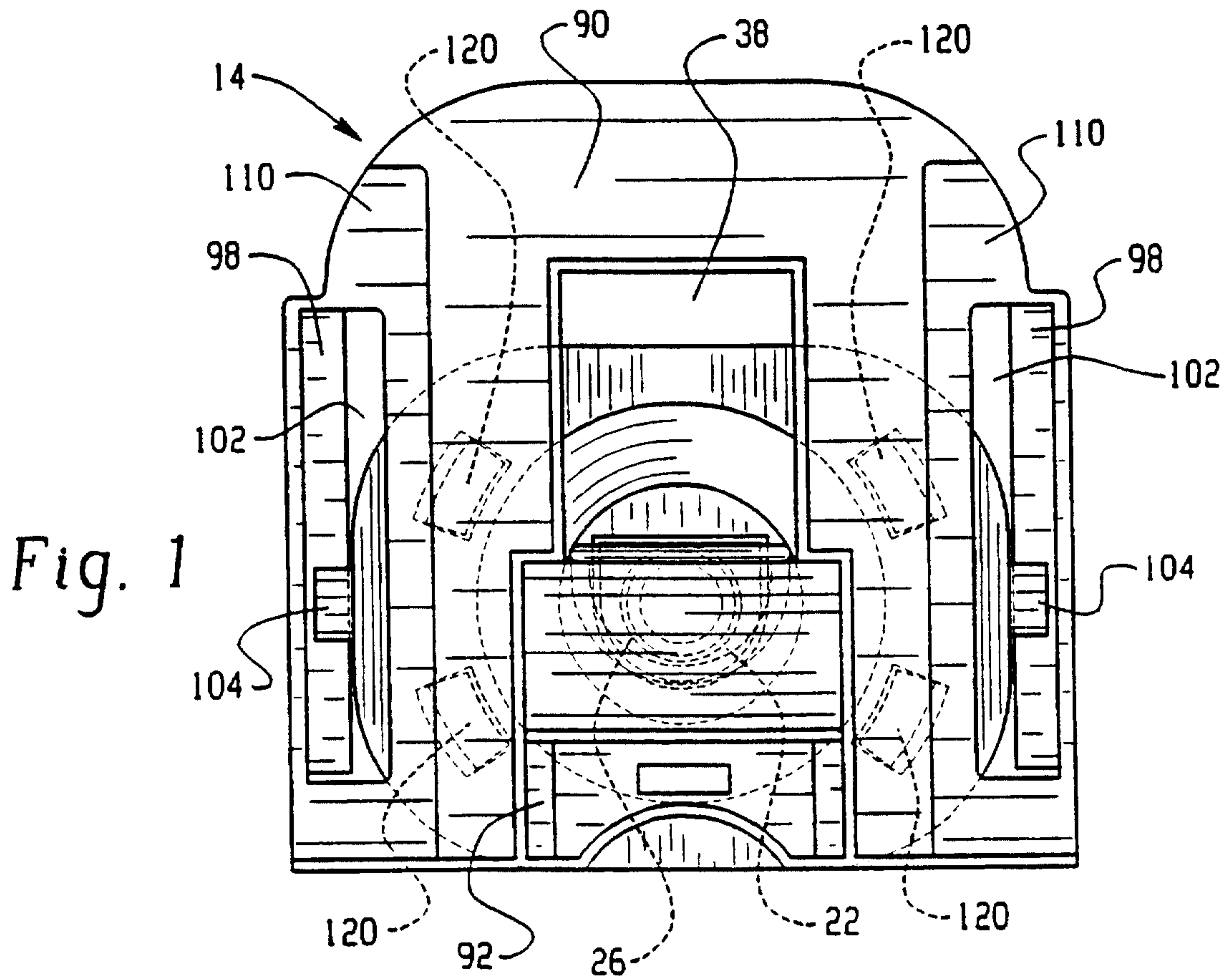

Fig. 1

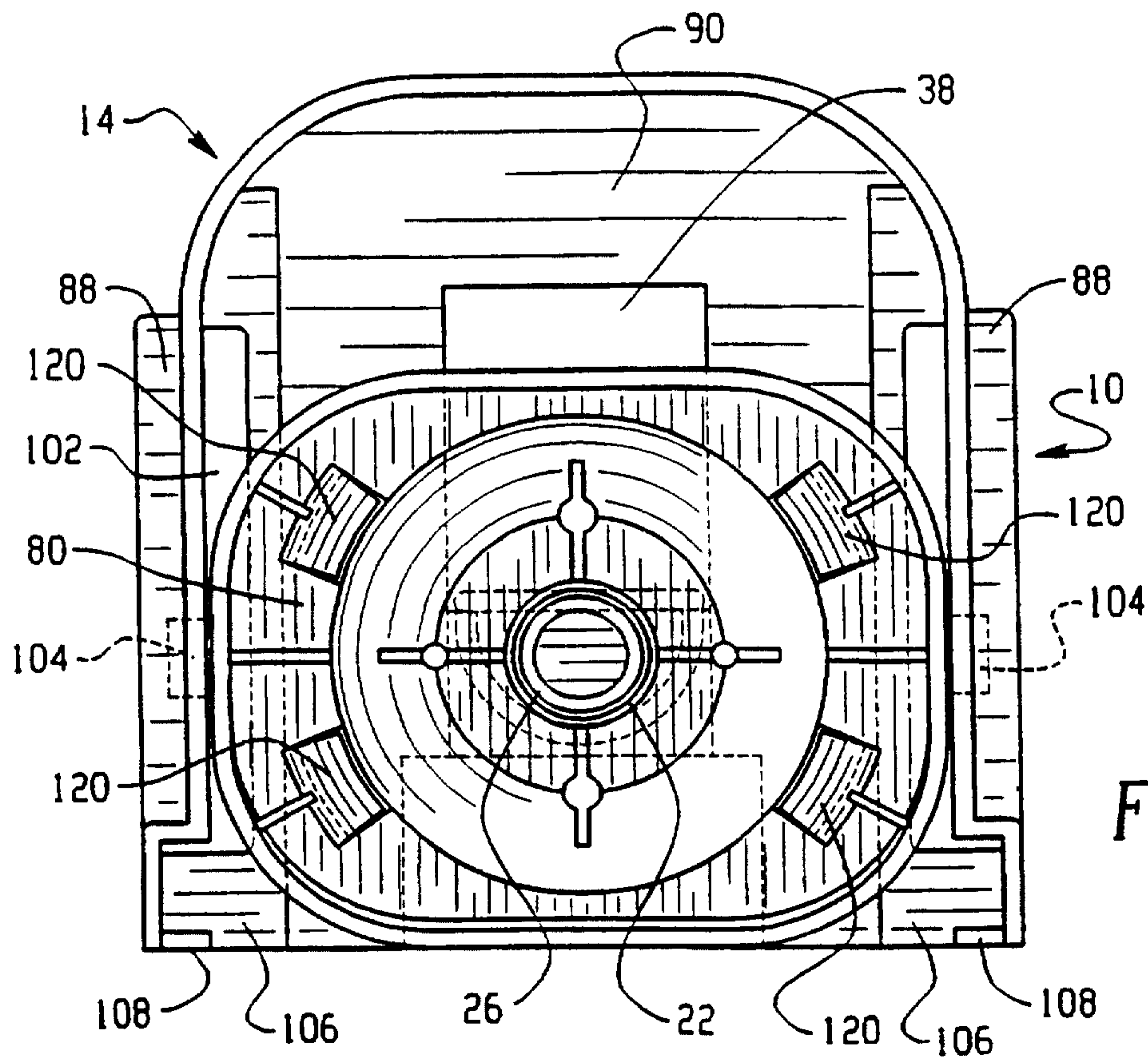

Fig. 2

Fig. 3

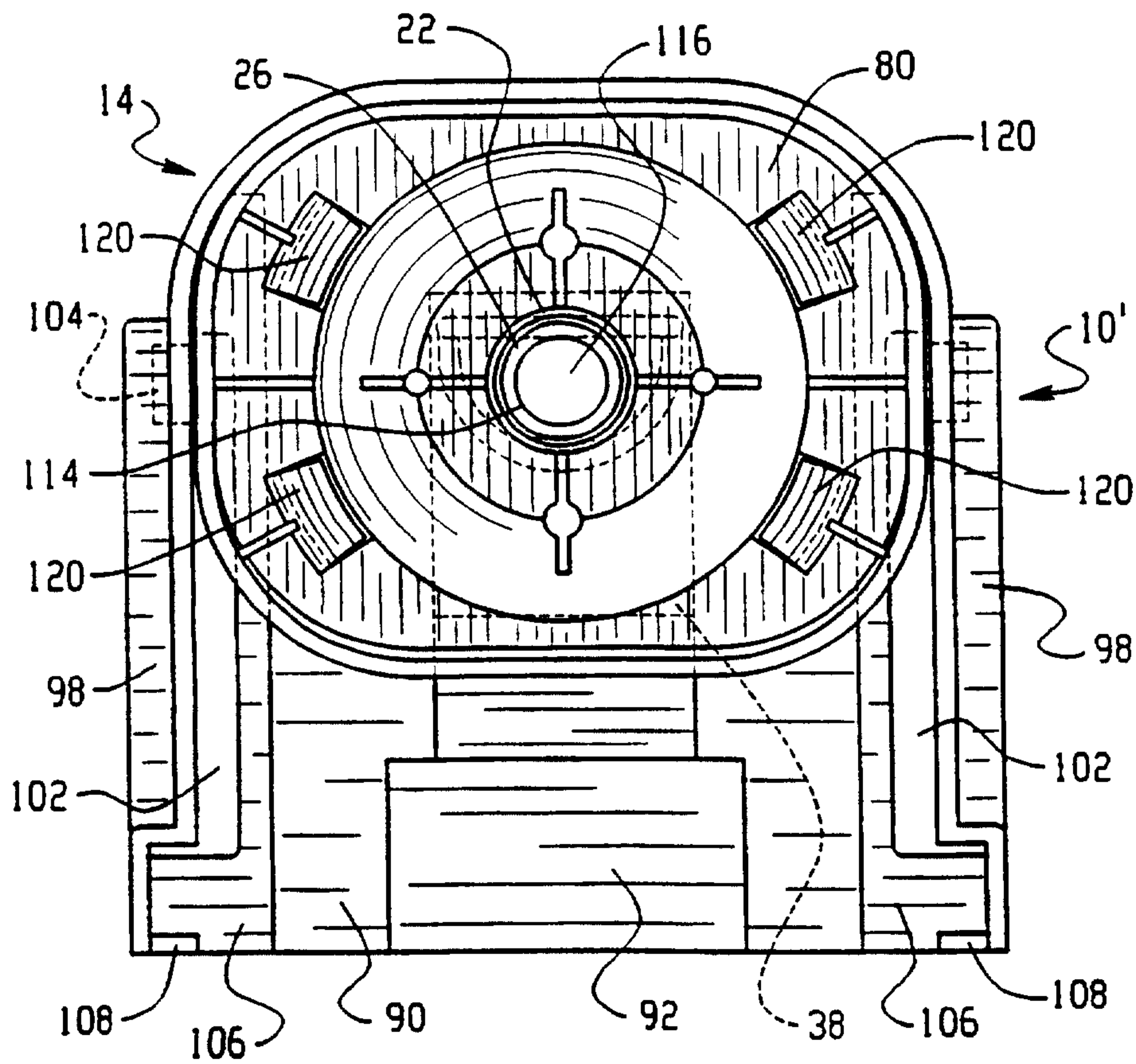
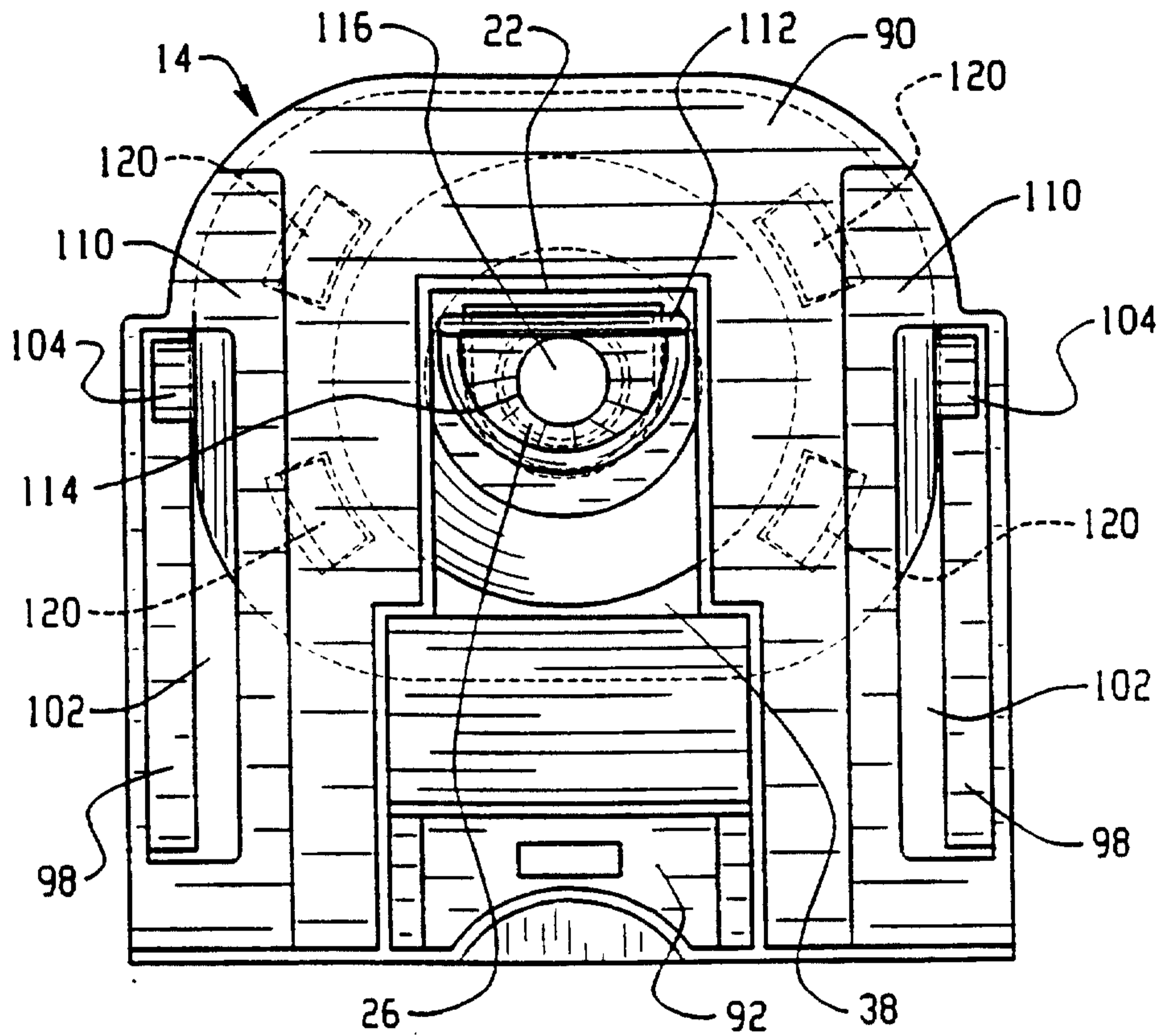

Fig. 4

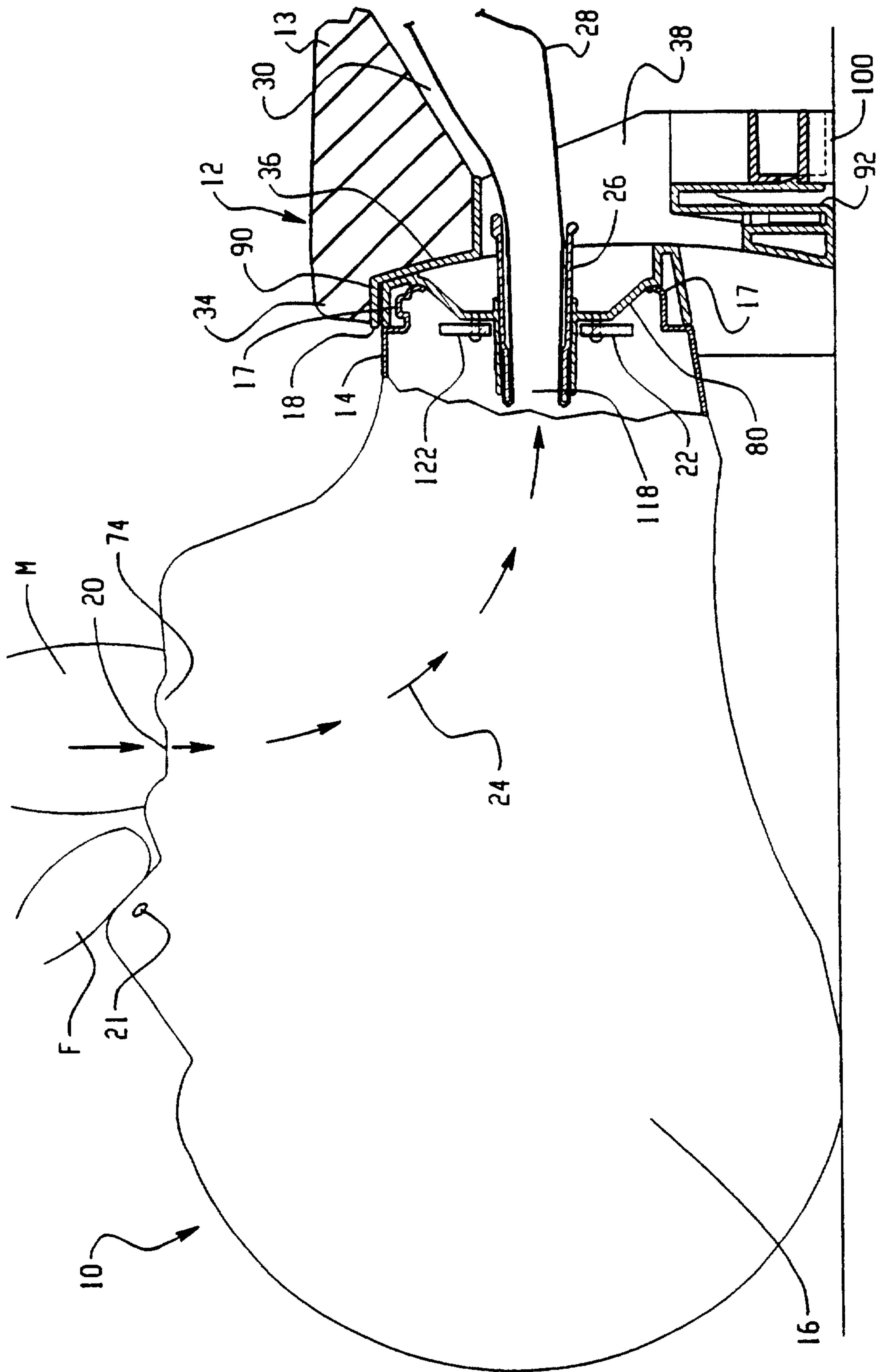

Fig. 5

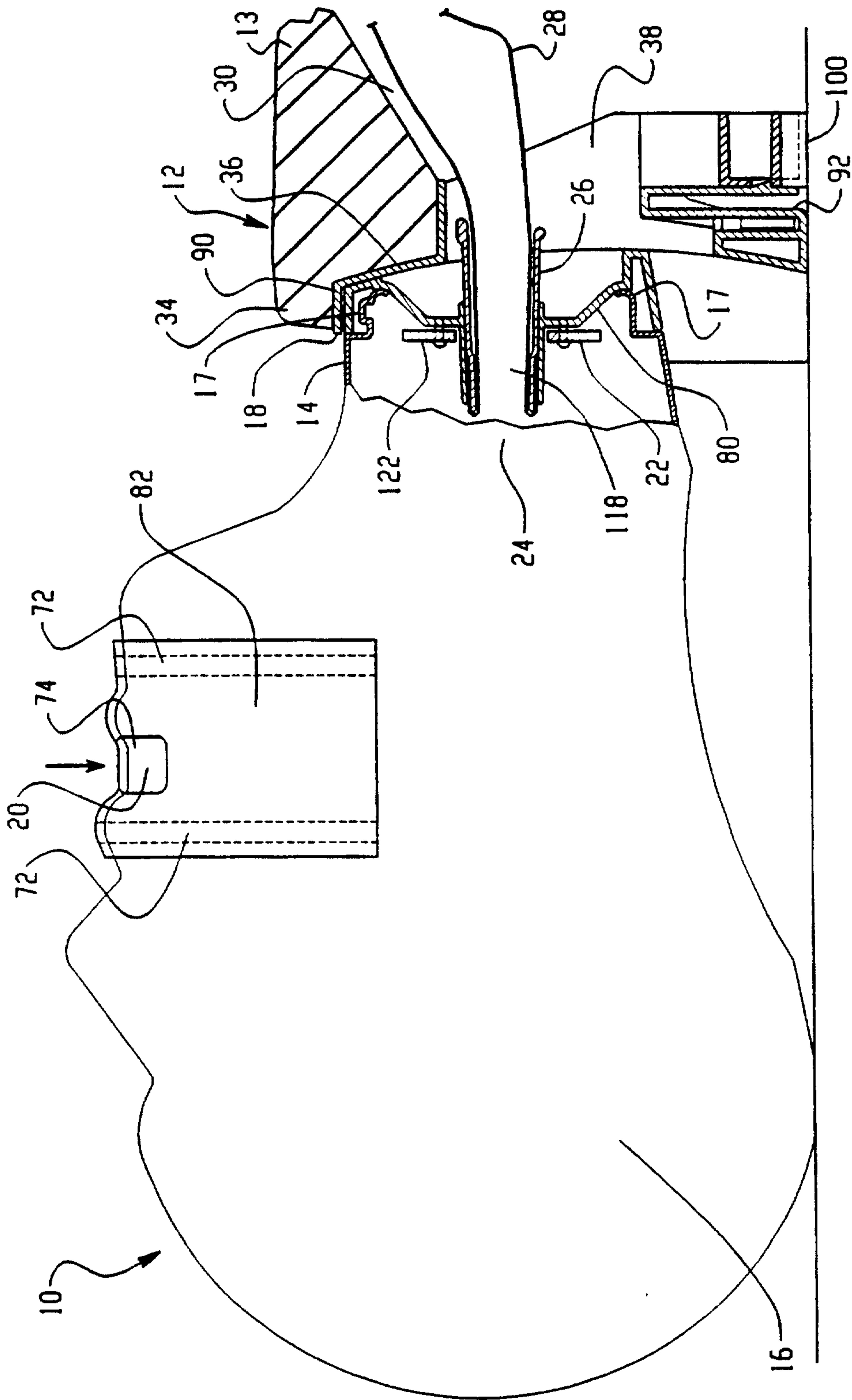

Fig. 5A

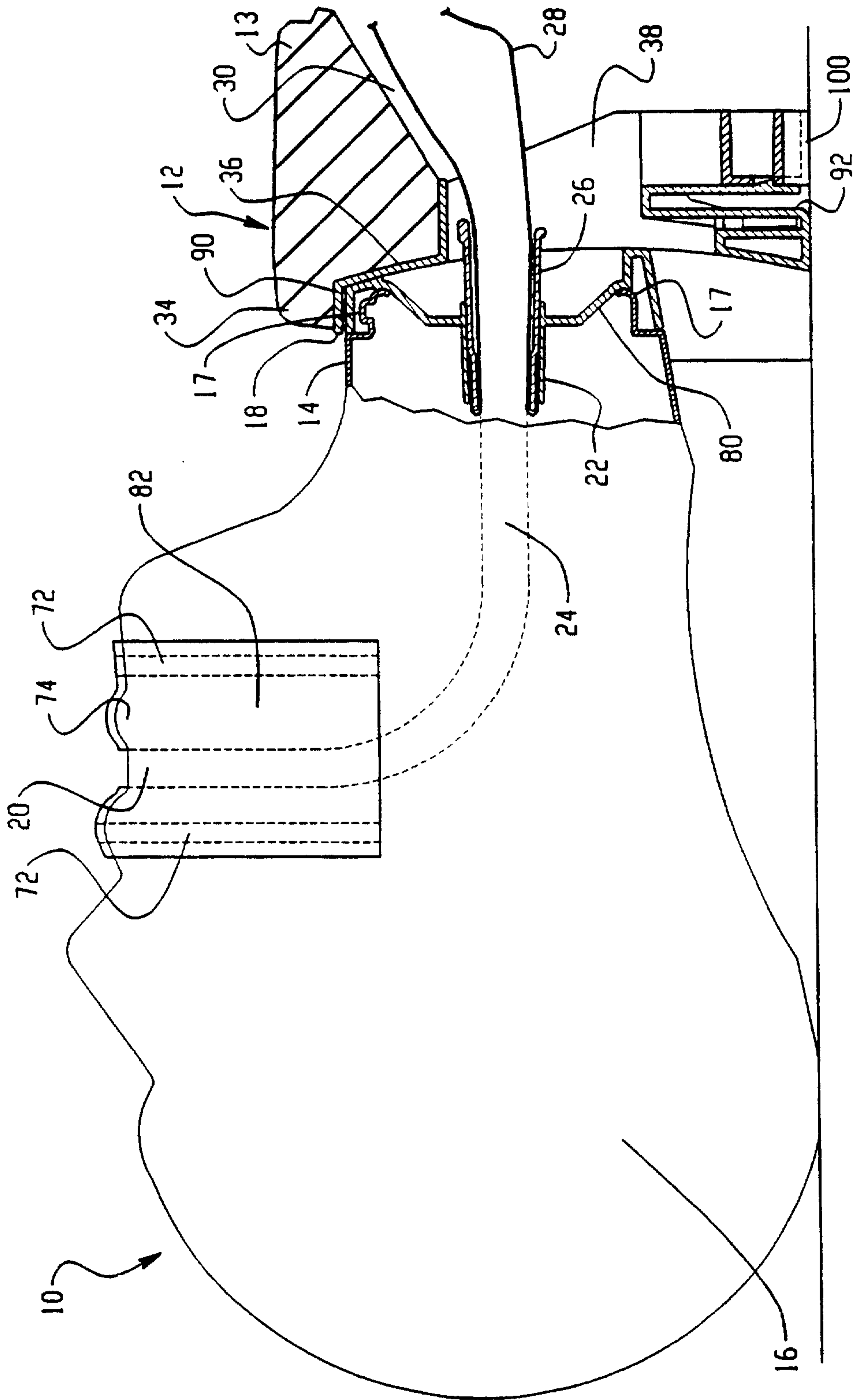

Fig. 5B

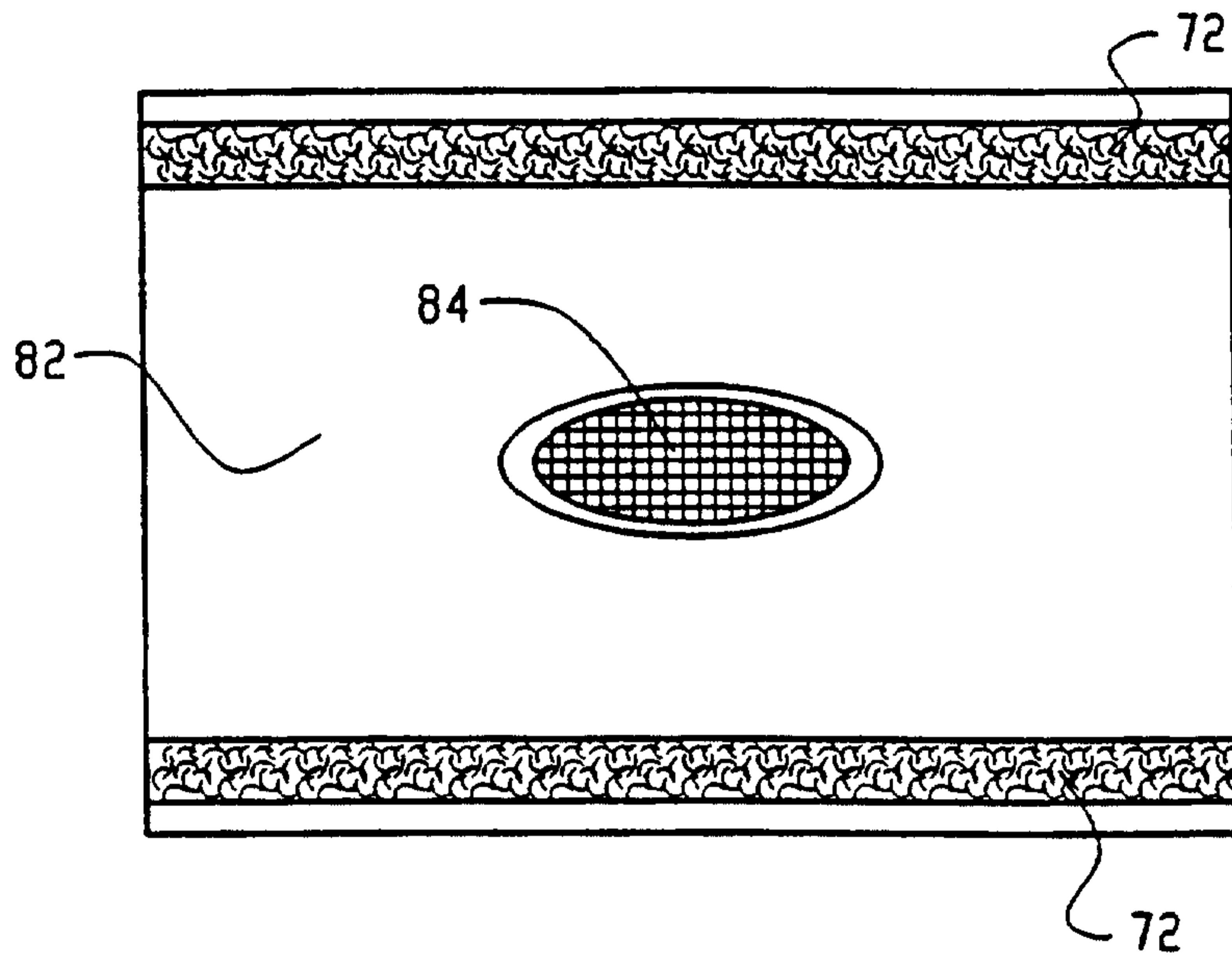

Fig. 5C

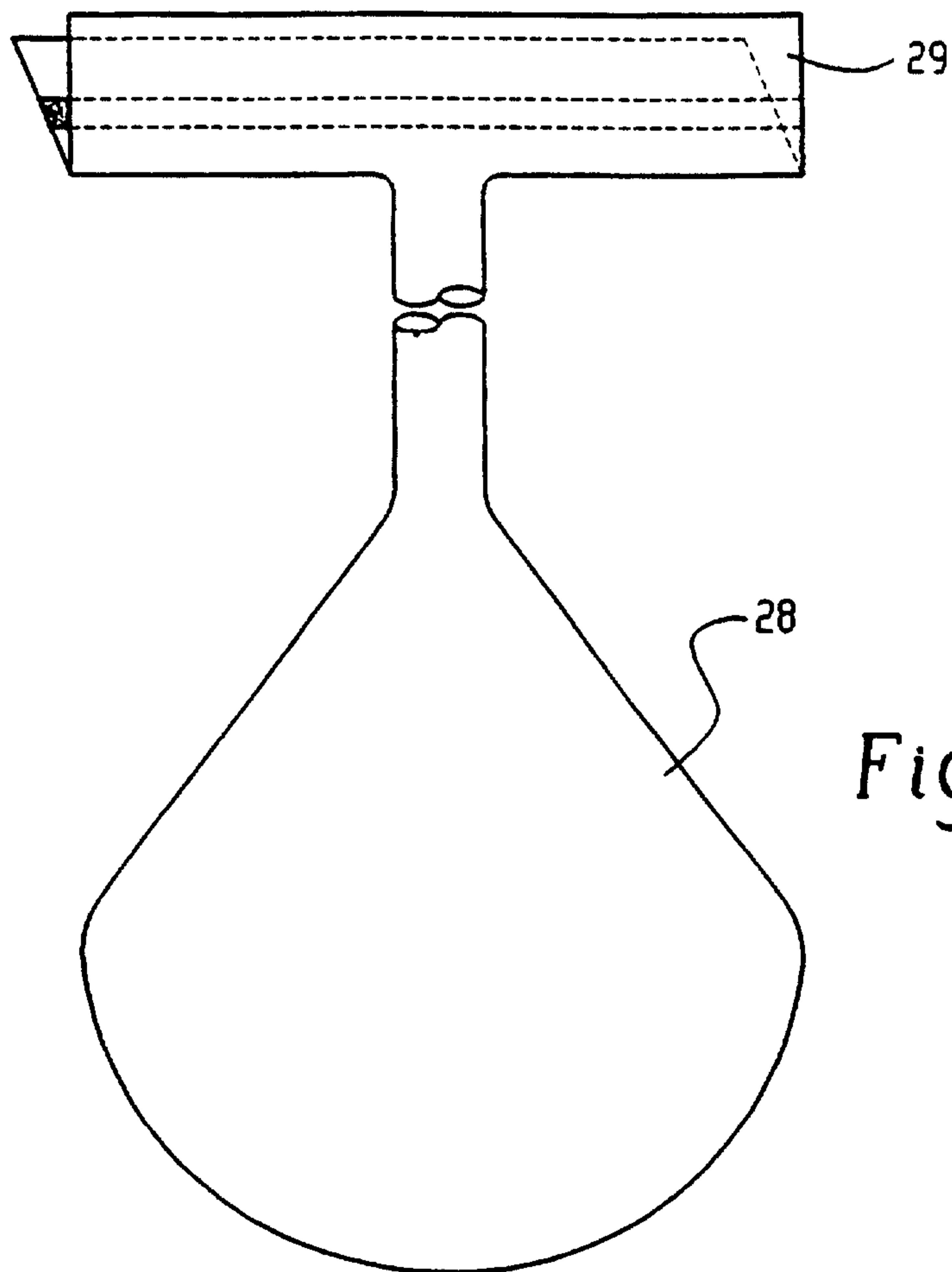

Fig. 5D

7/25

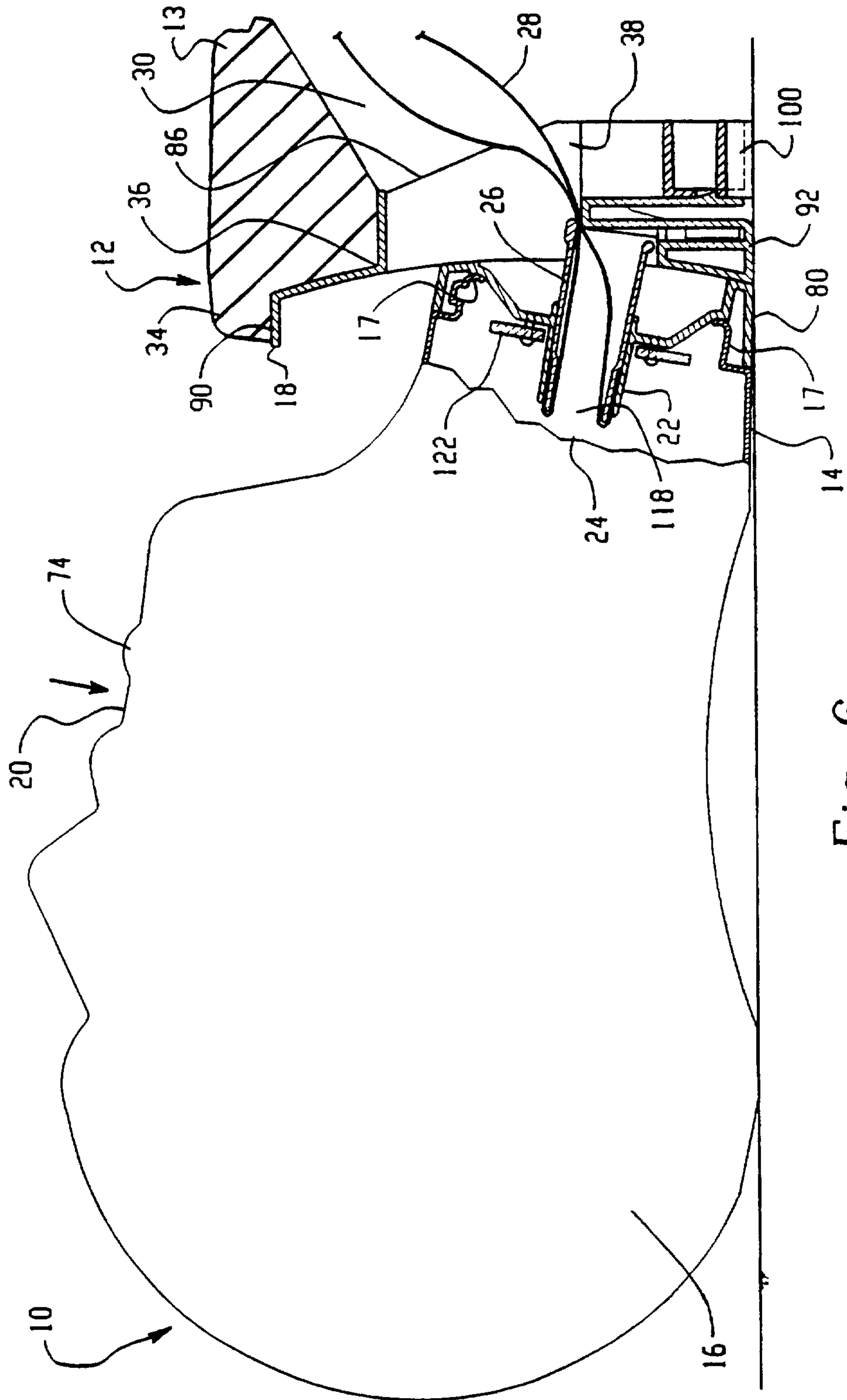

Fig. 6

8/25

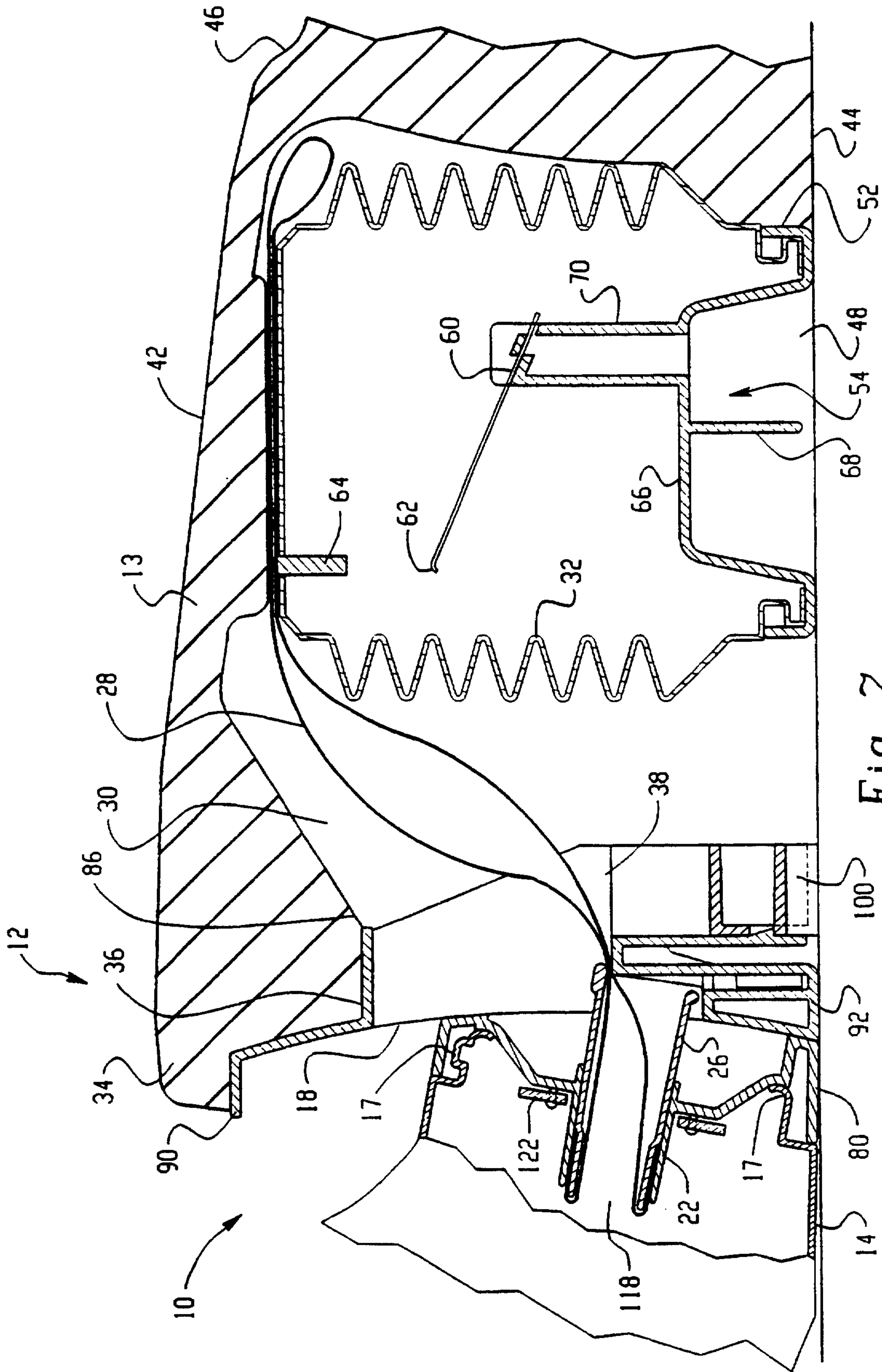

Fig. 7

9/25

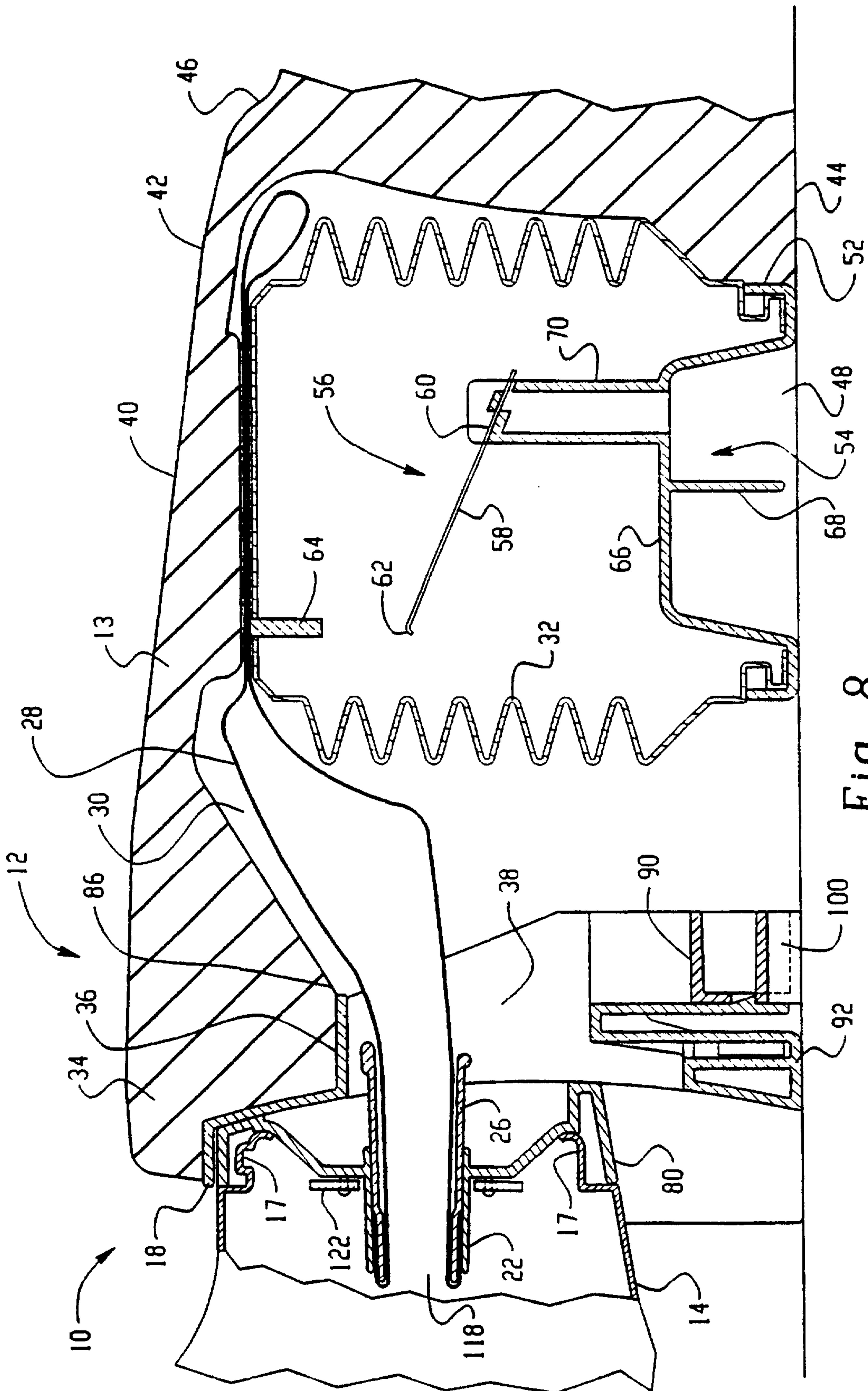

Fig. 8

11/25

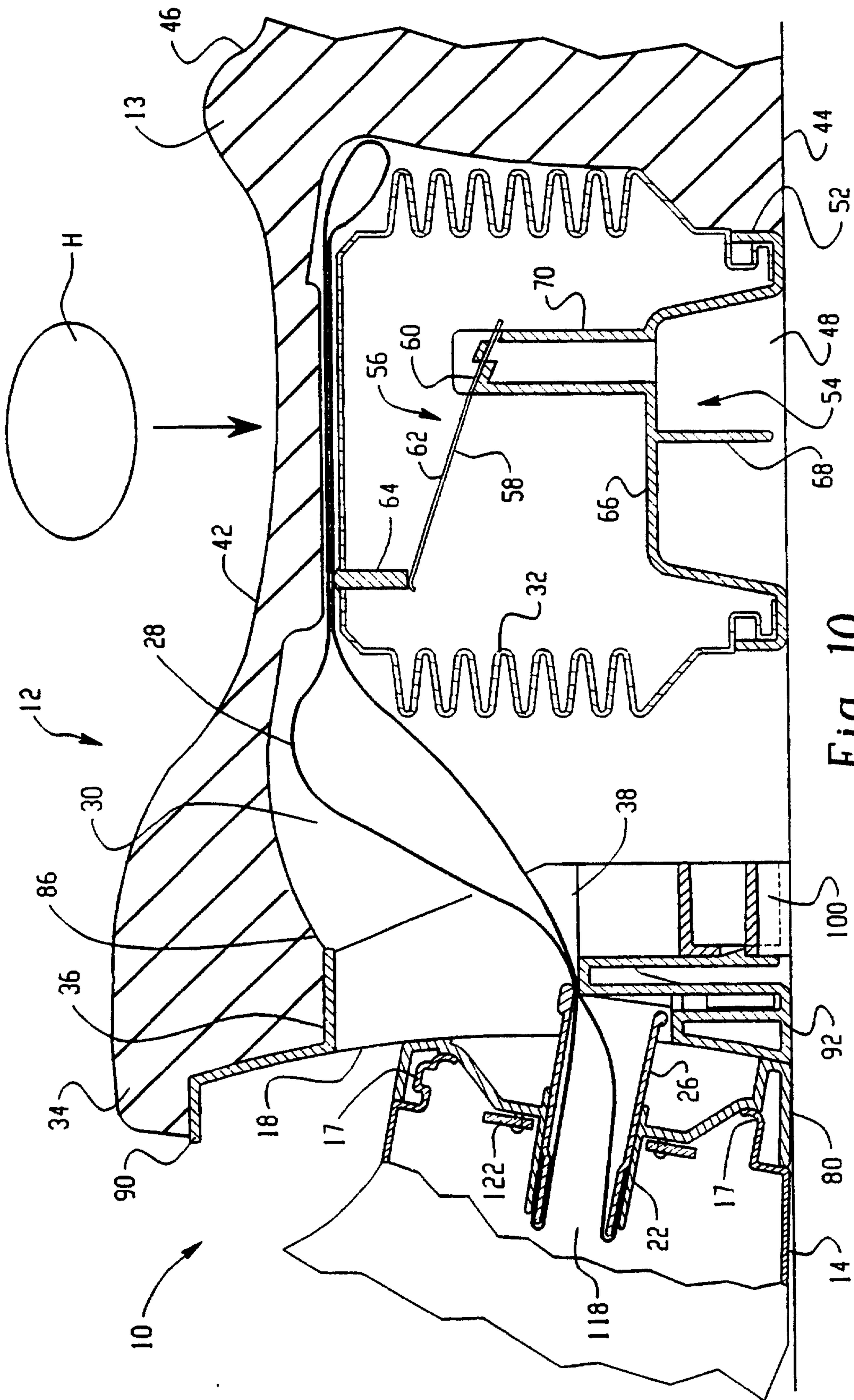

Fig. 10

12/25

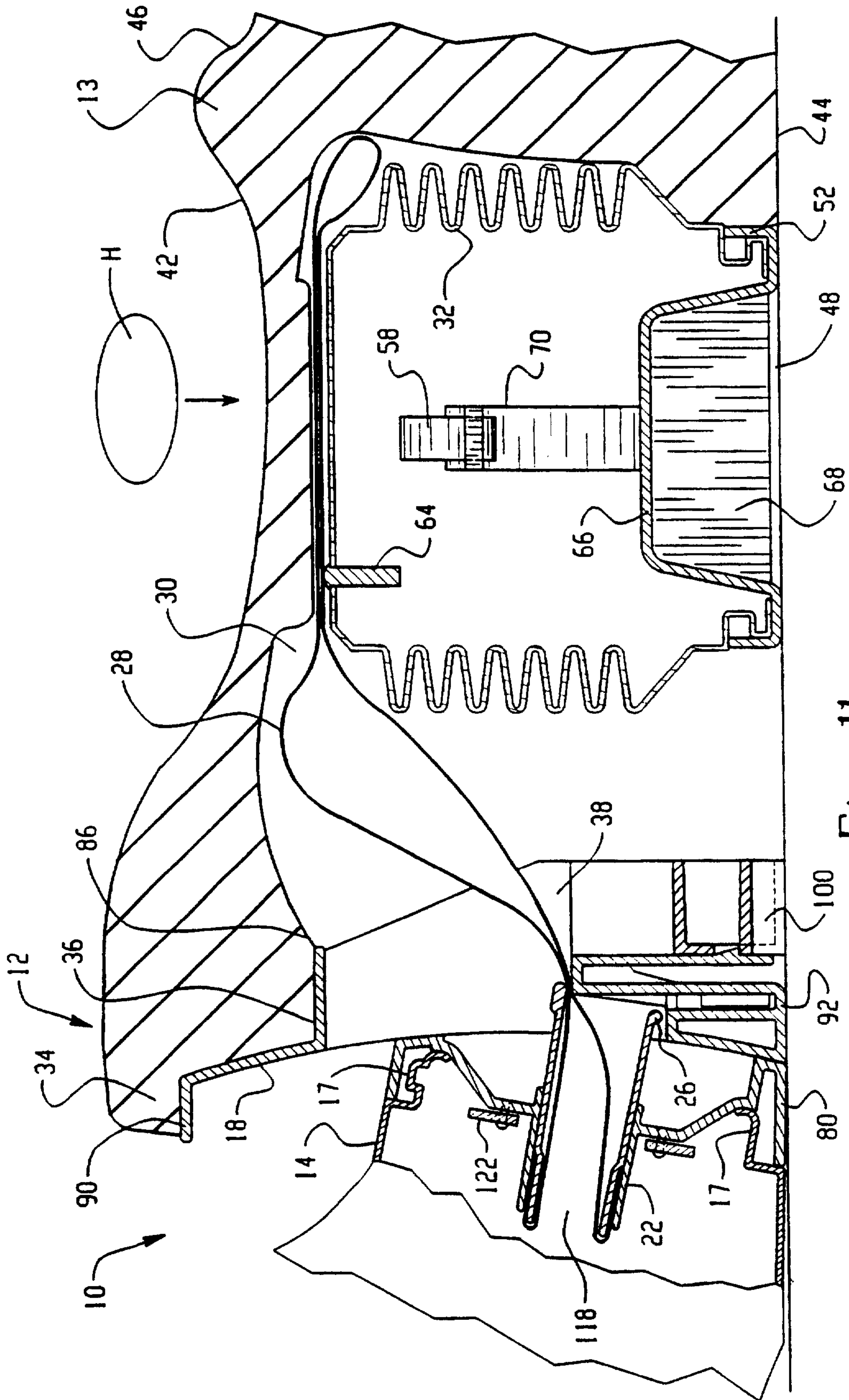

Fig. 11

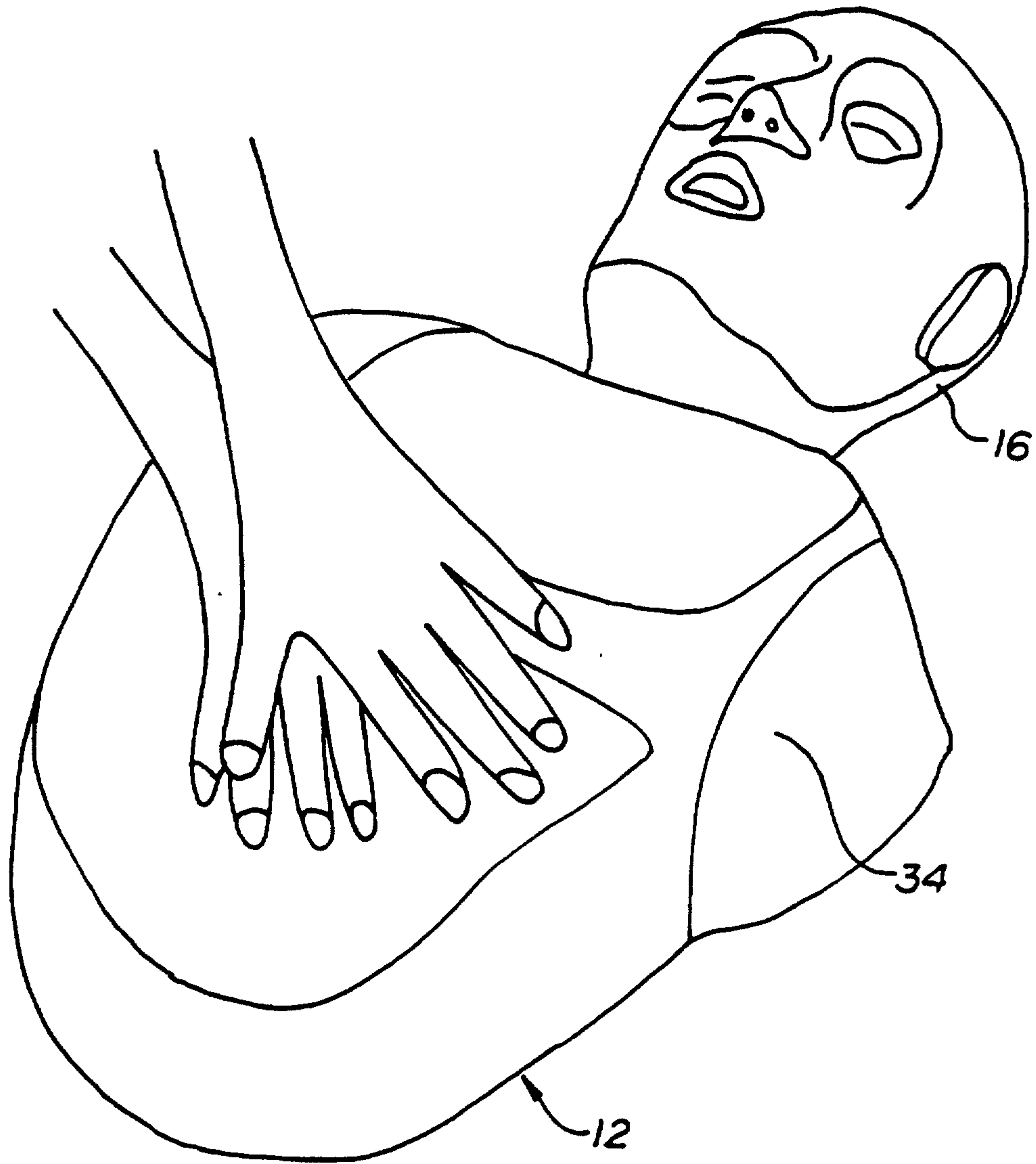

Fig. 12

14/25

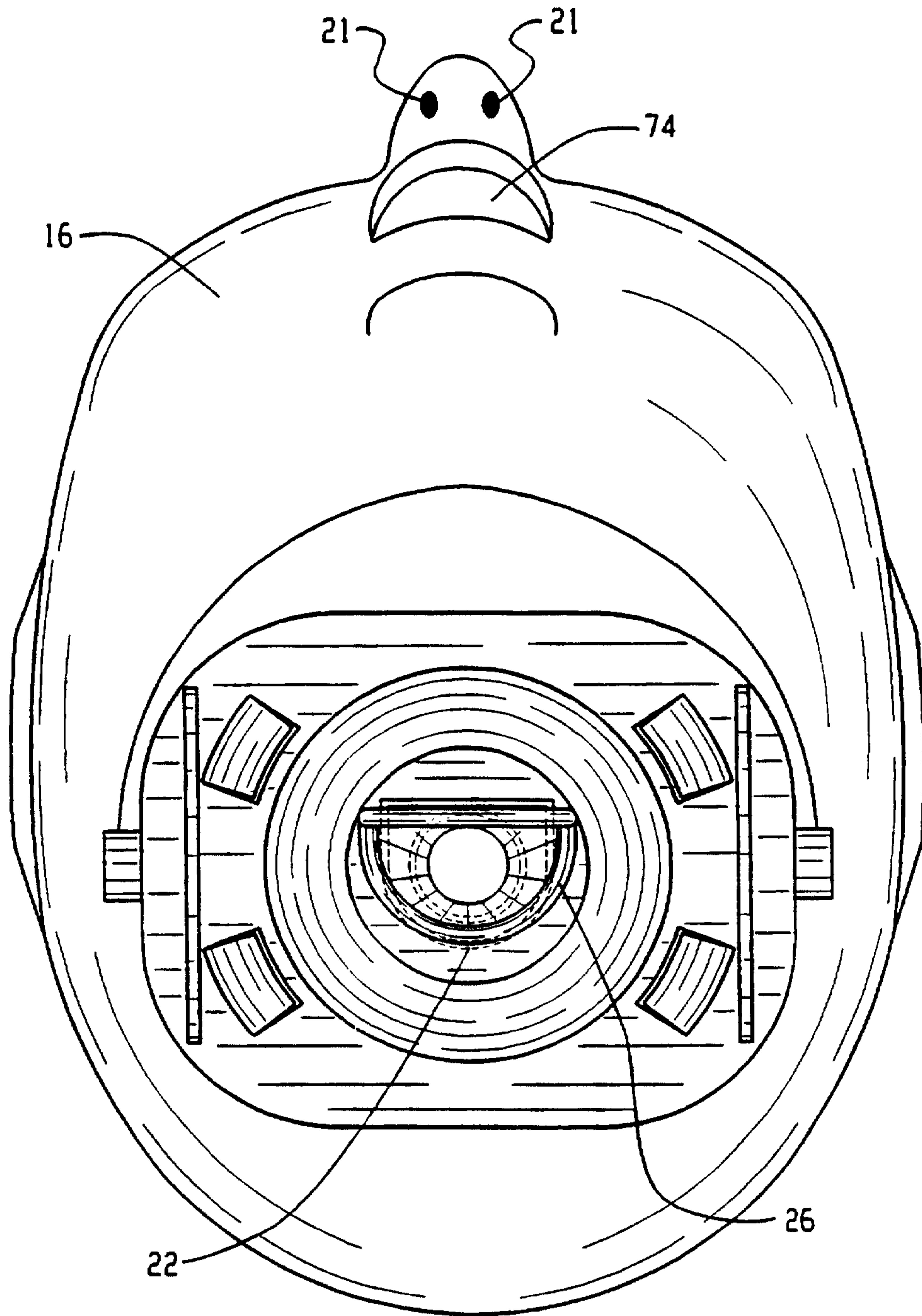

Fig. 13

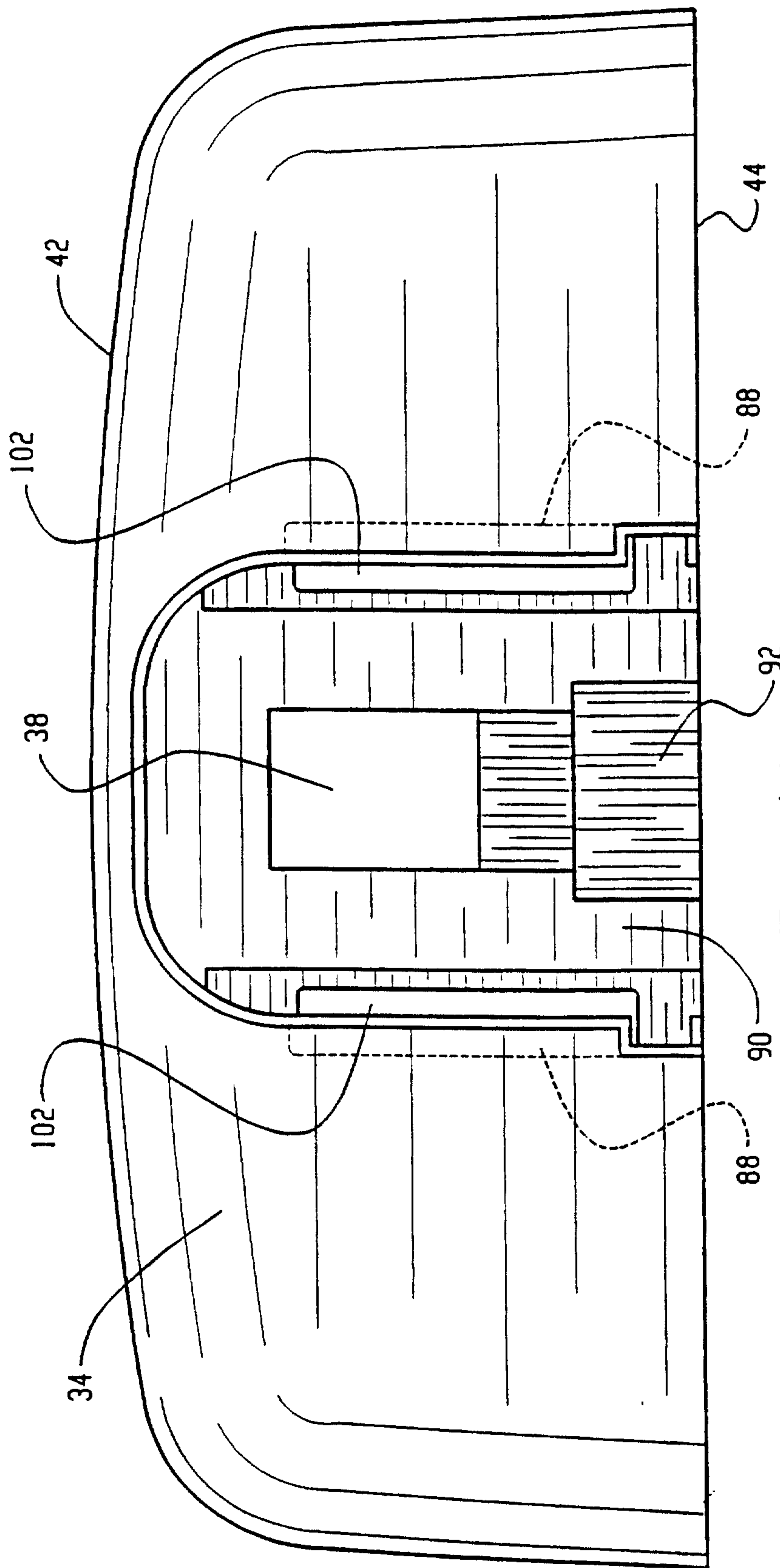

Fig. 14

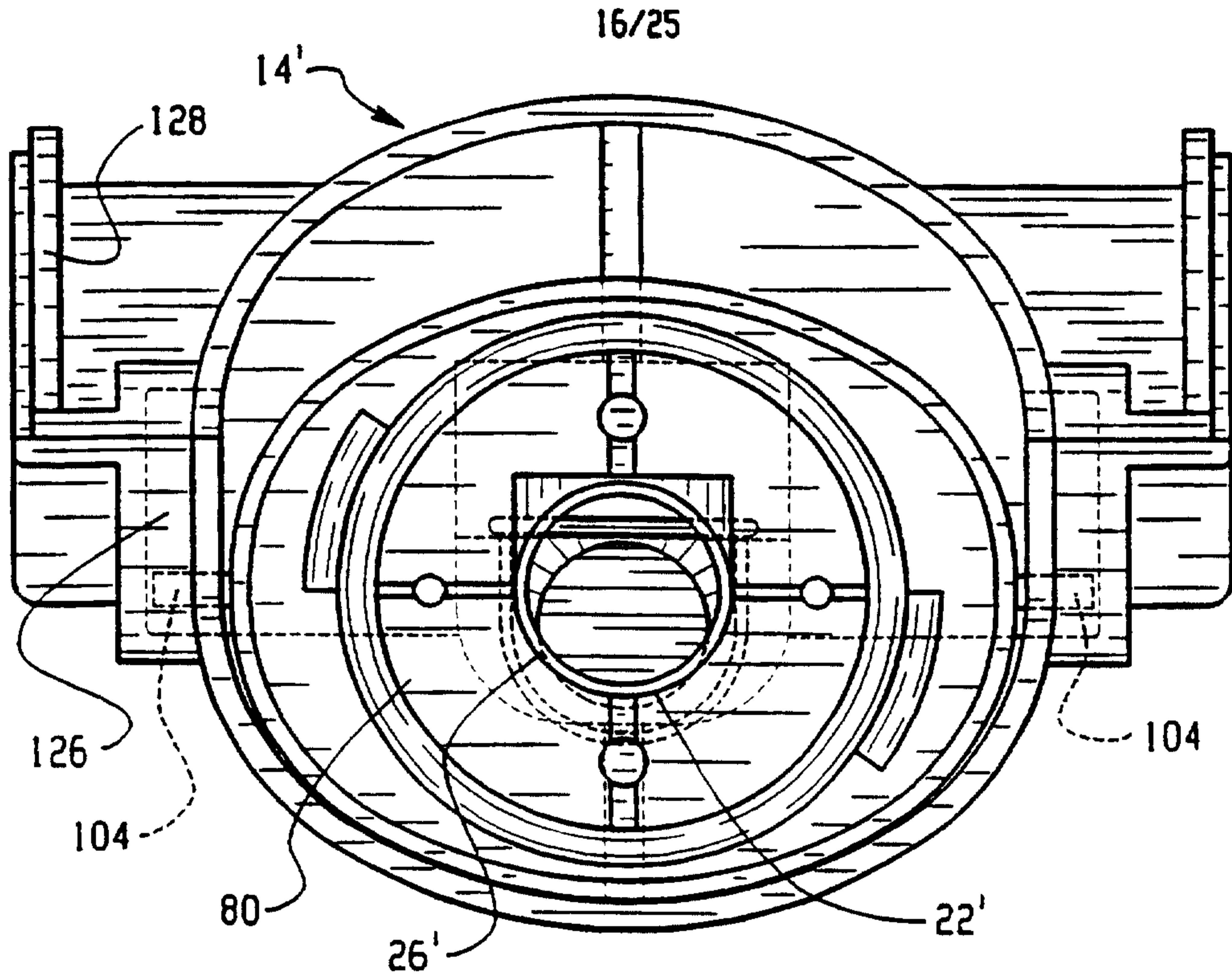

Fig. 15

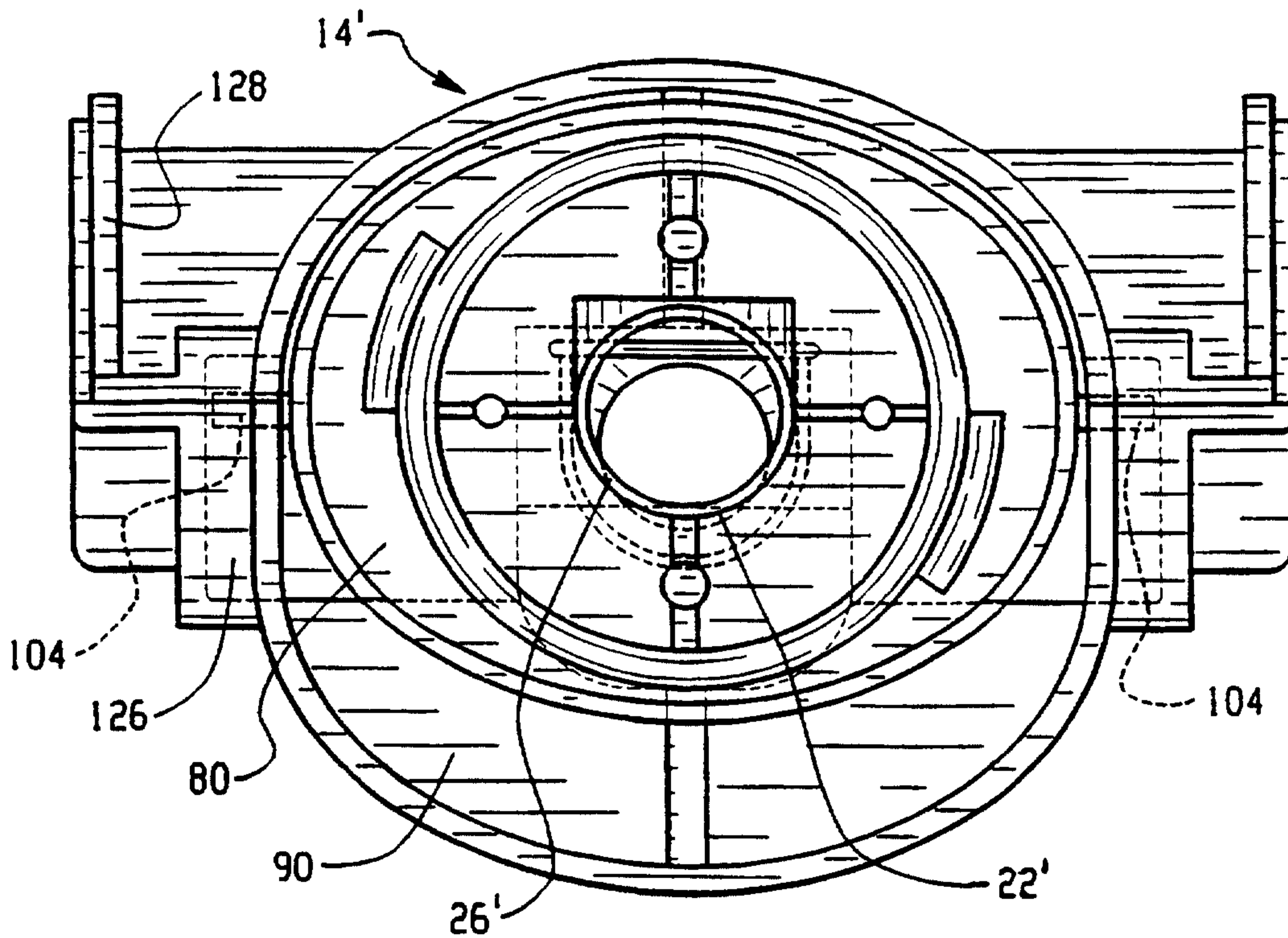

Fig. 16

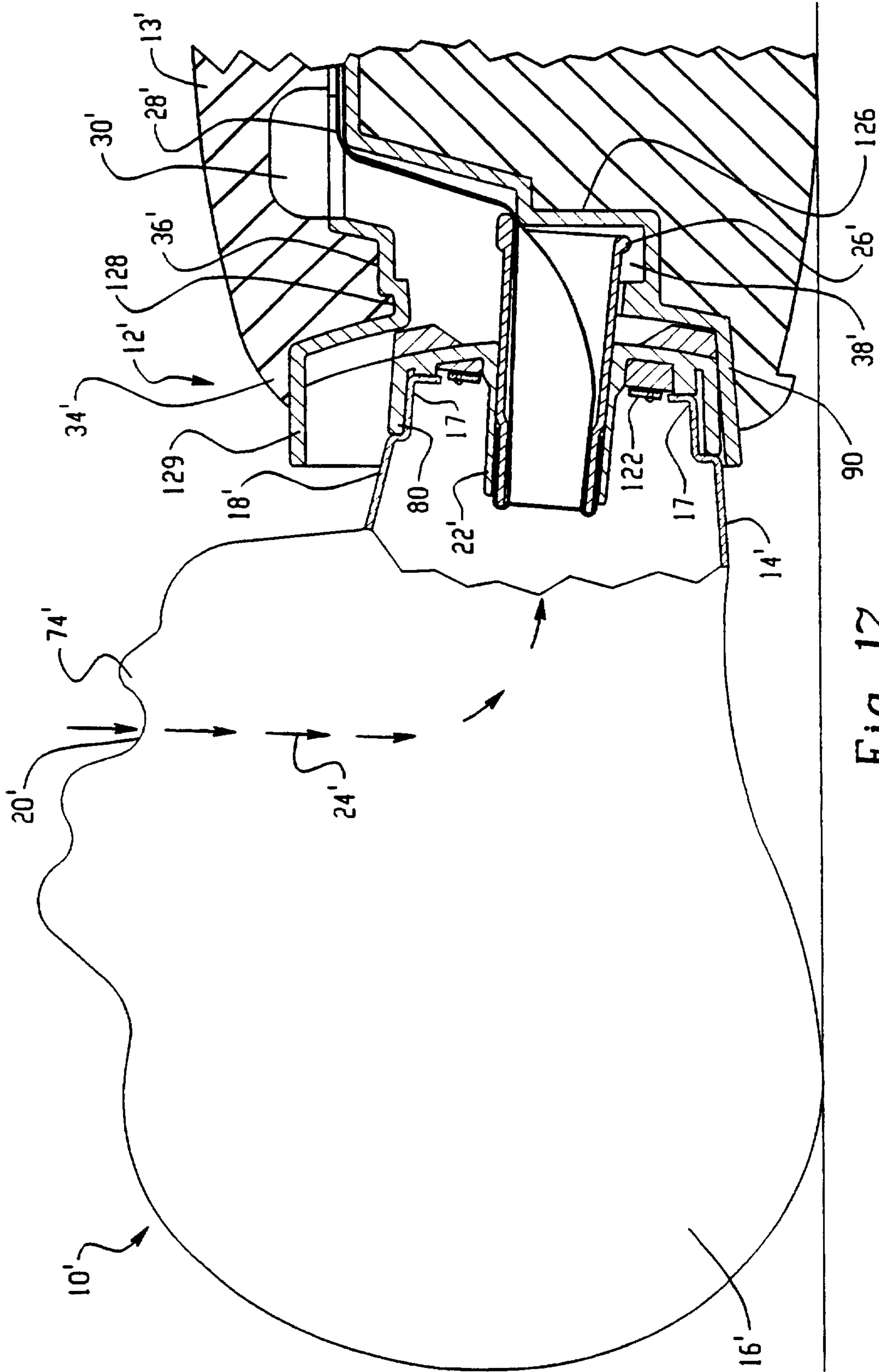

Fig. 17

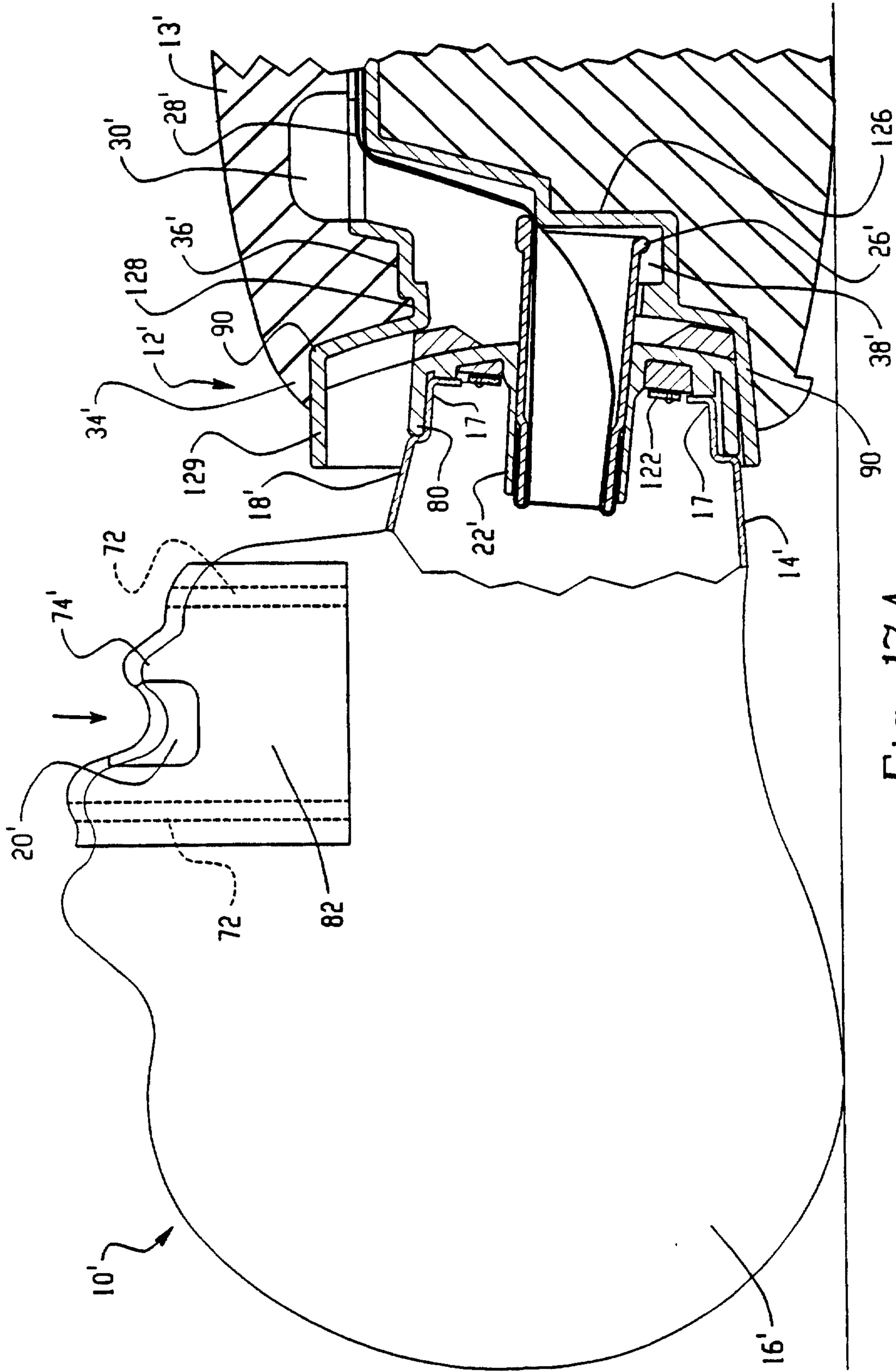

Fig. 17A

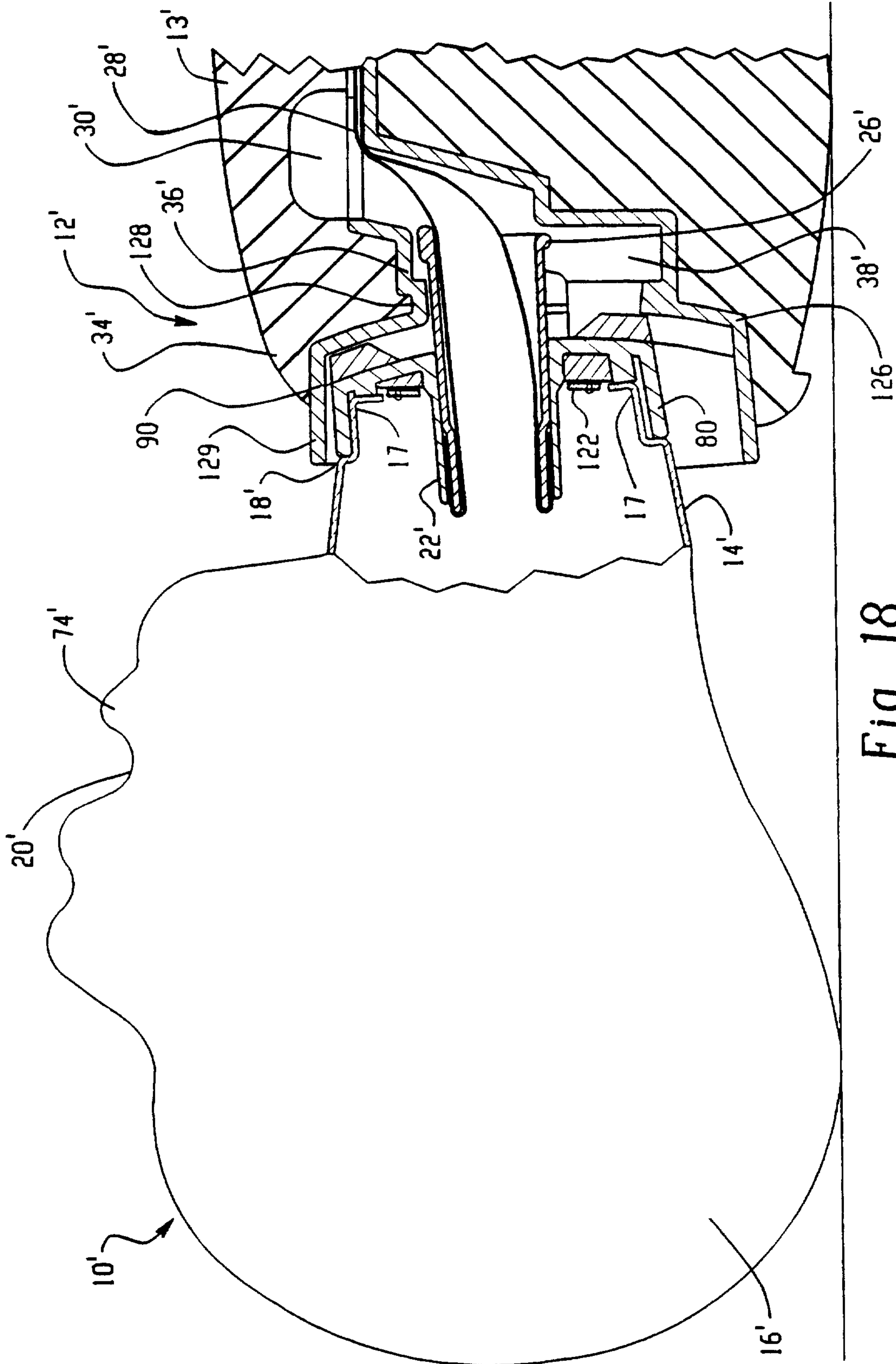

Fig. 18

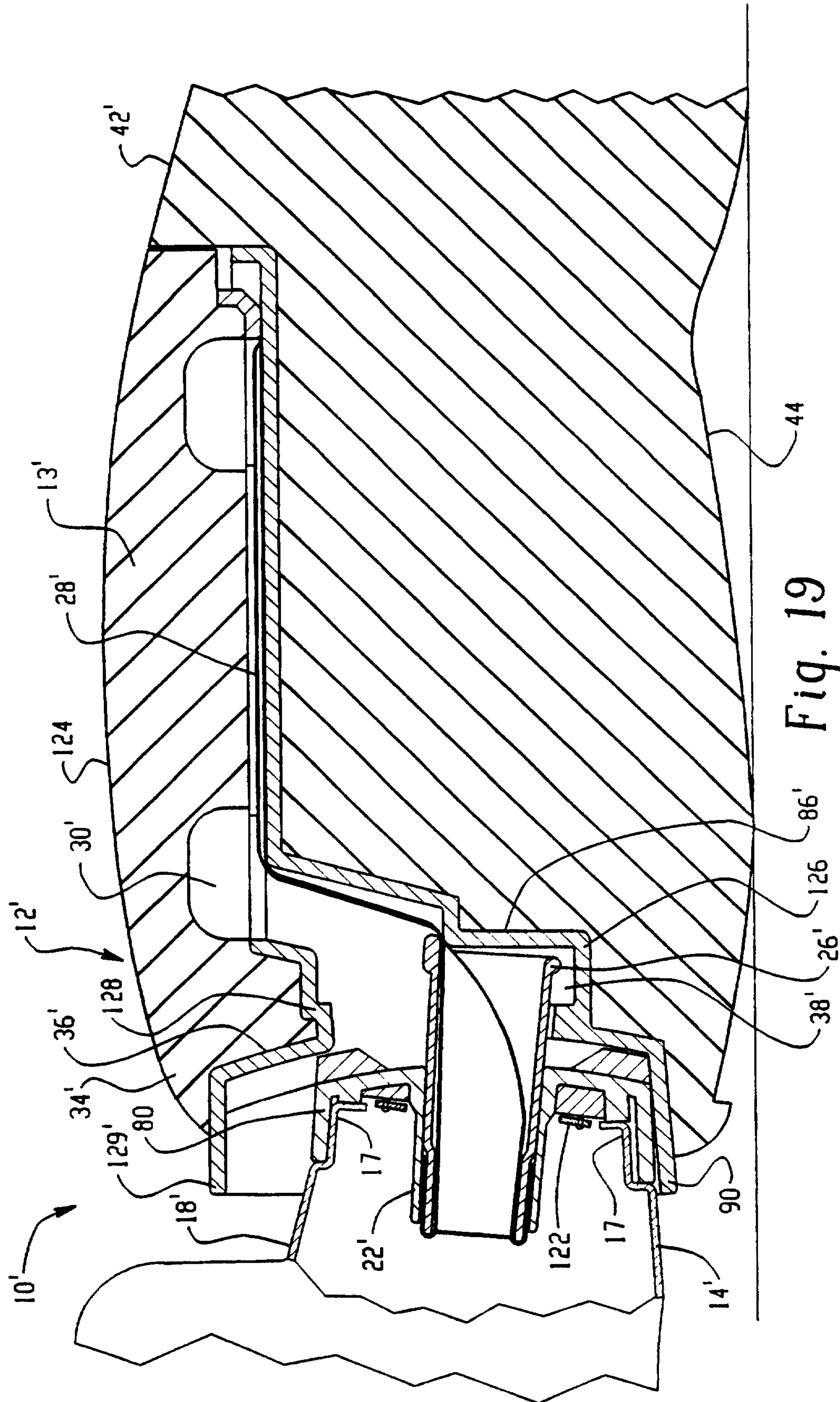

Fig. 19

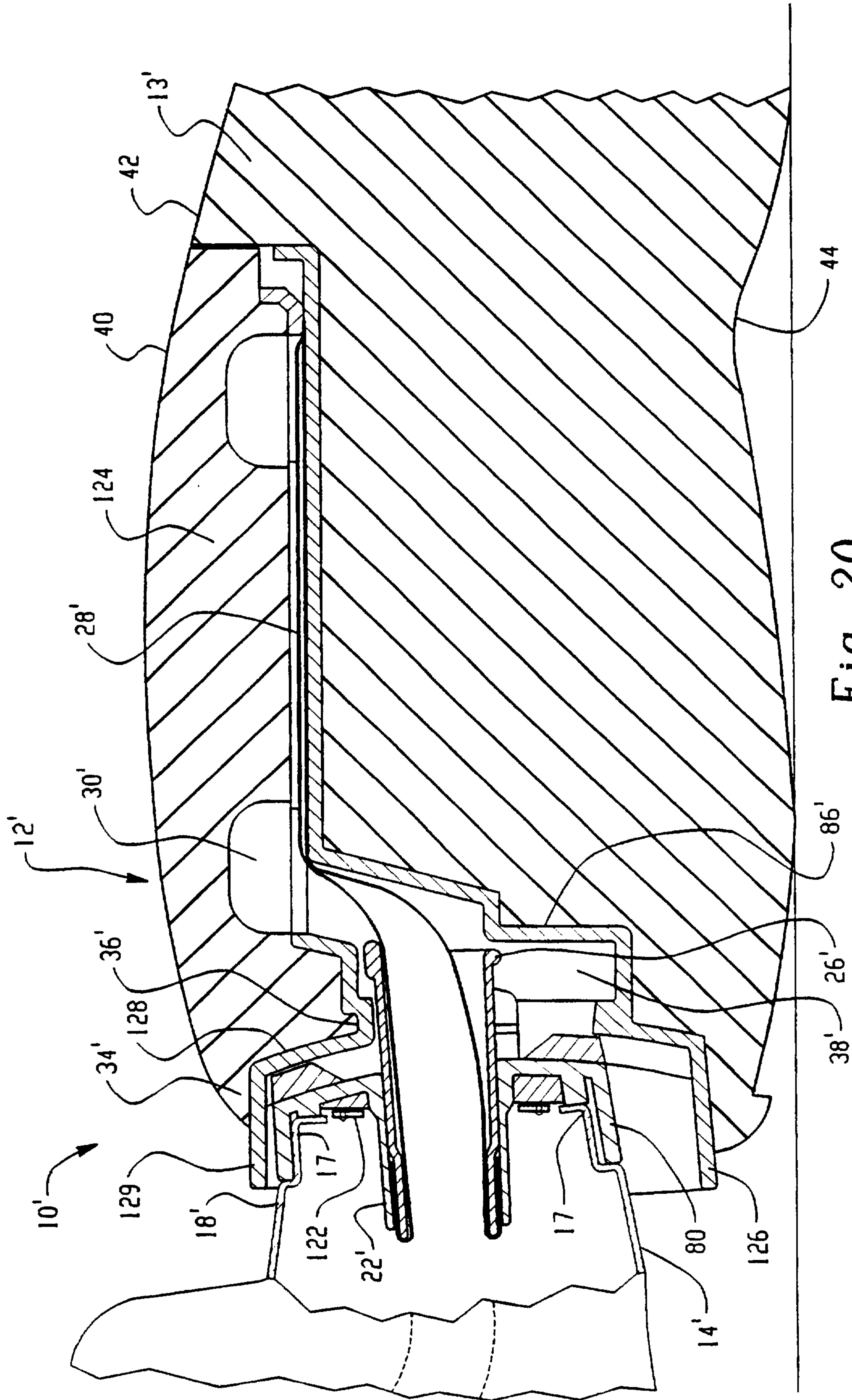

Fig. 20

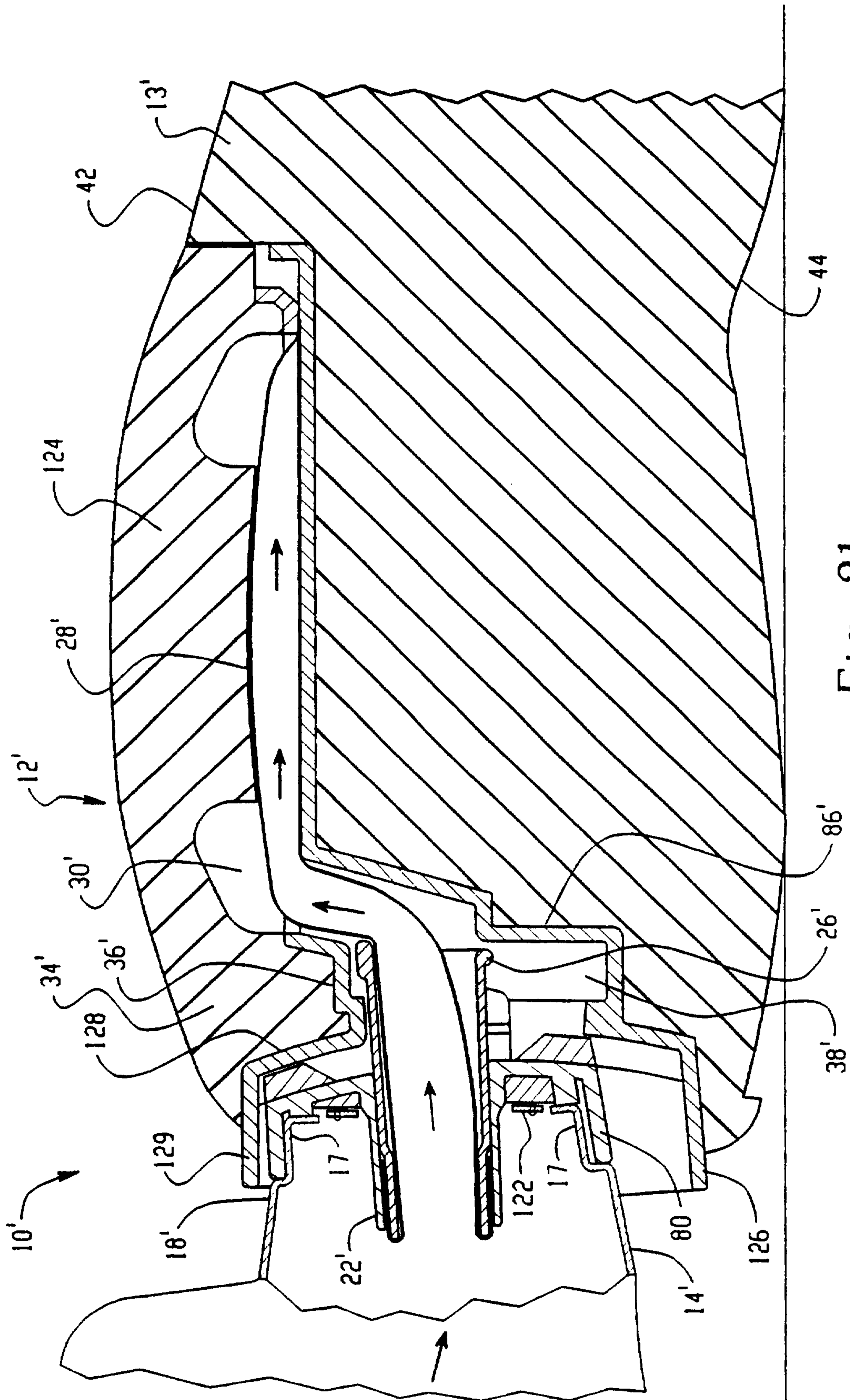

Fig. 21

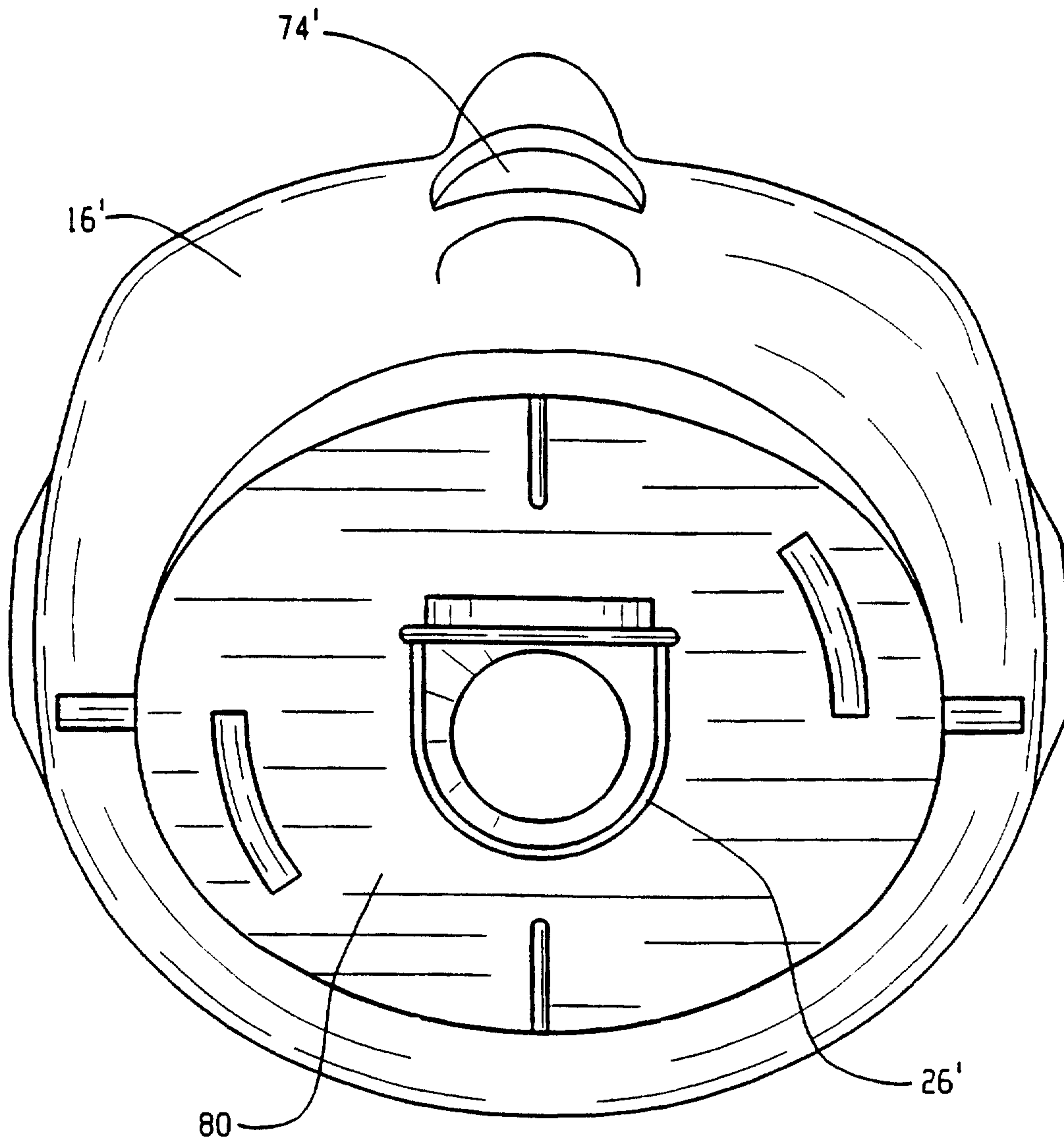

Fig. 22

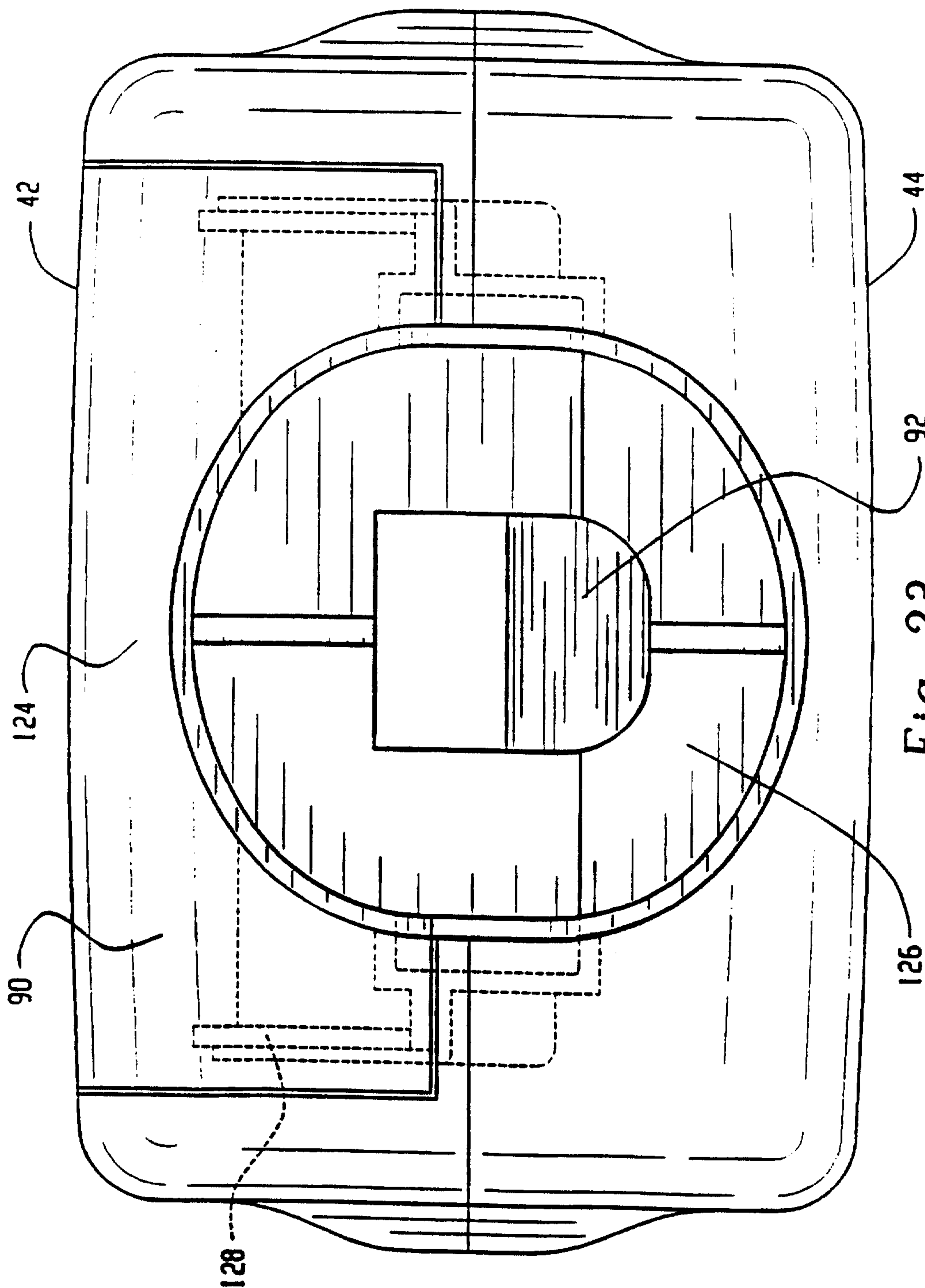

Fig. 23

