



INTERNATIONAL APPLICATION PUBLISHED UNDER THE PATENT COOPERATION TREATY (PCT)

<p>(51) International Patent Classification⁶ : F28F 3/08, B21D 53/04</p>	A1	<p>(11) International Publication Number: WO 99/45332 (43) International Publication Date: 10 September 1999 (10.09.99)</p>
<p>(21) International Application Number: PCT/FI99/00164 (22) International Filing Date: 4 March 1999 (04.03.99) (30) Priority Data: 980501 4 March 1998 (04.03.98) FI (71) Applicant (for all designated States except US): VAHTERUS OY [FI/FI]; Pruukintie 7, FIN-23600 Kalanti (FI). (72) Inventor; and (75) Inventor/Applicant (for US only): PIRILÄ, Timo [FI/FI]; Piirontanhua 31, FIN-23660 Kalanti as. (FI). (74) Agent: TURUN PATENTTI-TOIMISTO OY; P.O. Box 99, FIN-20521 Turku (FI).</p>		<p>(81) Designated States: AL, AM, AT, AU, AZ, BA, BB, BG, BR, BY, CA, CH, CN, CU, CZ, DE, DK, EE, ES, FI, GB, GD, GE, GH, GM, HR, HU, ID, IL, IN, IS, JP, KE, KG, KP, KR, KZ, LC, LK, LR, LS, LT, LU, LV, MD, MG, MK, MN, MW, MX, NO, NZ, PL, PT, RO, RU, SD, SE, SG, SI, SK, SL, TJ, TM, TR, TT, UA, UG, US, UZ, VN, YU, ZW, ARIPO patent (GH, GM, KE, LS, MW, SD, SL, SZ, UG, ZW), Eurasian patent (AM, AZ, BY, KG, KZ, MD, RU, TJ, TM), European patent (AT, BE, CH, CY, DE, DK, ES, FI, FR, GB, GR, IE, IT, LU, MC, NL, PT, SE), OAPI patent (BF, BJ, CF, CG, CI, CM, GA, GN, GW, ML, MR, NE, SN, TD, TG).</p> <p>Published With international search report. Before the expiration of the time limit for amending the claims and to be republished in the event of the receipt of amendments. In English translation (filed in Finnish).</p>
<p>(54) Title: HEAT EXCHANGER PLATE AND PLATE HEAT EXCHANGER</p>		
<p>(57) Abstract</p>		
<p>The invention relates to a plate heat exchanger plate (1) which contains alternative locations (4, 5) for flow openings, the locations of which can be changed to adjust the ridge angle between the ridges of the corrugations (2) of the adjacent plates (1) in a plate heat exchanger composed of plates (1) in order to improve the heat transfer and flow characteristics. The plates (1) may also be provided with a location (6) for a central hole.</p>		

FOR THE PURPOSES OF INFORMATION ONLY

Codes used to identify States party to the PCT on the front pages of pamphlets publishing international applications under the PCT.

AL	Albania	ES	Spain	LS	Lesotho	SI	Slovenia
AM	Armenia	FI	Finland	LT	Lithuania	SK	Slovakia
AT	Austria	FR	France	LU	Luxembourg	SN	Senegal
AU	Australia	GA	Gabon	LV	Latvia	SZ	Swaziland
AZ	Azerbaijan	GB	United Kingdom	MC	Monaco	TD	Chad
BA	Bosnia and Herzegovina	GE	Georgia	MD	Republic of Moldova	TG	Togo
BB	Barbados	GH	Ghana	MG	Madagascar	TJ	Tajikistan
BE	Belgium	GN	Guinea	MK	The former Yugoslav Republic of Macedonia	TM	Turkmenistan
BF	Burkina Faso	GR	Greece			TR	Turkey
BG	Bulgaria	HU	Hungary	ML	Mali	TT	Trinidad and Tobago
BJ	Benin	IE	Ireland	MN	Mongolia	UA	Ukraine
BR	Brazil	IL	Israel	MR	Mauritania	UG	Uganda
BY	Belarus	IS	Iceland	MW	Malawi	US	United States of America
CA	Canada	IT	Italy	MX	Mexico	UZ	Uzbekistan
CF	Central African Republic	JP	Japan	NE	Niger	VN	Viet Nam
CG	Congo	KE	Kenya	NL	Netherlands	YU	Yugoslavia
CH	Switzerland	KG	Kyrgyzstan	NO	Norway	ZW	Zimbabwe
CI	Côte d'Ivoire	KP	Democratic People's Republic of Korea	NZ	New Zealand		
CM	Cameroon			PL	Poland		
CN	China	KR	Republic of Korea	PT	Portugal		
CU	Cuba	KZ	Kazakistan	RO	Romania		
CZ	Czech Republic	LC	Saint Lucia	RU	Russian Federation		
DE	Germany	LI	Liechtenstein	SD	Sudan		
DK	Denmark	LK	Sri Lanka	SE	Sweden		
EE	Estonia	LR	Liberia	SG	Singapore		

HEAT EXCHANGER PLATE AND PLATE HEAT EXCHANGER

The invention relates to a plate of a plate heat exchanger, which plate is used especially in welded plate heat exchangers to separate the flow ducts and to form heat transfer surfaces. The plate is circular in shape and contains at least two flow openings for supplying and discharging a heat transfer medium from the ducts formed by the plates. The plates of the plate heat exchanger, which are advantageously made of metal, are provided with corrugations for improving the heat transfer characteristics and supporting the ducts formed between the plates of the plate heat exchanger. The plates of the plate heat exchanger are welded together in pairs at the outer perimeters of the flow openings, and the plate pairs are connected together by welding the plates of the plate pairs at their outer perimeter to the plates of the other plate pairs.

A conventional plate heat exchanger is composed of superimposed plates which form a stack of plates which is clamped between two end plates by means of tie bars. The ducts formed by the plates and the flow openings connected thereto are sealed at their outer perimeters by means of separate sealings. Even though sealings have undergone an intensive development, the most significant problem in such heat exchangers is the leaking of the sealings, which can be caused by the temperature, corrosion, aging, or another corresponding factor. The plates of such plate heat exchangers are typically rectangular-shaped, and the flow openings, usually four in number, are placed in the vicinity of the corners. The heat transfer surfaces are typically provided with straight corrugations, or the corrugations are arranged in a v-shape. The plates are stacked on top of each other in such a way that the corrugations are not in parallel, but an angle is formed between their ridges, the width of which angle significantly affects the heat transfer characteristics. Because the plates of a conventional plate heat exchanger are manufactured by pressing, the

process of changing the angle between the ridges has always required a new, expensive pressing tool.

Several solutions have been presented to adjust the angle between the ridges of the plate. Attempts have been made to find a solution by changing the structure of the plate heat exchanger or by developing the pressing tools. The Finnish patent publication FI 79409 presents a plate heat exchanger in which circular or polygonal plates are stacked on top of each other, and the stack of plates hereby formed is supported between end plates. Unlike conventional plate heat exchangers, the plates are not provided with flow openings, but the flows are directed in ducts between the plates from outside the plates. Thus the angle between the ridges can be freely chosen by means of circular and polygonal plates within the restrictions set by the polygonal shape. However, the construction according to the publication is expensive to manufacture and the problems of tightness have not been solved satisfactorily.

The Finnish patent publication FI 84659 discloses a solution which contains features typical both of a conventional plate heat exchanger and of a pipe heat exchanger. Similarly to conventional plate heat exchangers, one heat transfer medium is arranged to flow via flow openings located in the plates. A feature related to the tube heat exchanger is the outer cell which surrounds the heat exchanger. The most significant difference when compared with conventional solutions is the fact that the plates are welded together at the flow openings and outer perimeters. Plates according to this application can be used in a plate heat exchanger of the above-described type.

The Finnish patent publication FI 94395 presents a manufacturing method and a tool for producing a plate for a plate heat exchanger. In the method according to the publication, a pressing tool is used which contains several filling pieces

which either correspond to the normal corrugation or form a flow opening. The placement of the flow openings in the pressed heat exchanger plates can be altered by changing the places of the filling pieces, wherein the angle between the ridges in the plates constituting the heat exchanger changes as well. By
5 using the same pressing tool, it is possible to attain several different variations with respect to the ridge angle, depending, naturally, on the number of the filling pieces. Naturally, such pressing tools are more expensive to manufacture than conventional ones, but they are considerably less expensive than pressing tools manufactured separately for each ridge angle needed.

10

The purpose of this invention is to produce a circular, corrugated heat exchanger plate which contains at least one additional location for a pair of flow openings, which flow openings can be selected after pressing the heat exchanger plate. The corrugation of the heat exchanger plate is cut by the outer
15 perimeter of the flow opening in such a way that it is possible to cut a flow opening in the plate by means of the pressing tool. The number of the locations of the flow opening pairs determines the ridge angle alternatives in the heat exchanger plates. In practice, one or two additional locations are often sufficient for a pair of flow openings.

20

More precisely, the plate for a plate heat exchanger is characterized in what will be presented in the characterizing part of claim 1.

The plates for a plate heat exchanger according to the invention contain at least
25 two pairs of locations for the flow openings, wherein by providing the flow openings at the desired locations, the ridge angle between the ridges of the corrugations in the superimposed plates of the plate heat exchanger is adjusted and changed to attain the best possible heat transfer characteristics. The locations of the flow openings and the central hole are composed of straight,

smooth ring-like parts with a corrugation inside them. An opened central hole constitutes a flow duct for one heat transfer medium and/or functions as a duct in which a supporting means is placed. Unopened locations for the central hole and the flow openings constitute a part of the heat exchange surfaces in a plate heat exchanger composed of heat exchanger plates according to the invention.

5 In the plate heat exchanger, the ring-like straight part on the outer perimeter of the plate as well as the ring-like straight parts in the locations of the flow openings and the central hole, are at least on two different levels in order to close the flow ducts formed between the plates of the plate heat exchanger. In

10 a heat exchanger composed of heat exchanger plates according to the invention, the adjacent plates are welded together at their outer perimeters as well as at the outer perimeters of the central holes or at the flow openings. If the diameters of the plate blanks to be removed from the flow openings are sufficiently large, the locations of the flow openings can be formed as heat

15 exchanger plates which contain locations for alternative flow openings and the plates thus attained can be used to form smaller plate heat exchangers.

With a plate for a plate heat exchanger according to the invention, it is possible to achieve considerable advantages. The price of the pressing tool used in the

20 production of the plate does not differ from the price of a conventional tool. Plates for a plate heat exchanger can be manufactured to be stocked for future deliveries. The flow openings can be pressed after the heat exchanger has been thermally dimensioned before starting the assembly work. Because all the plates are produced with the same pressing tool, the plates are formed rapidly,

25 without changes in the settings of the pressing tool. If the plates to be pressed are sufficiently large in size, the plate blanks to be removed from the flow openings can be used as plates in a small plate heat exchanger, in which plates the locations of the flow openings have already been pressed. Even though the plate for a plate heat exchanger according to the invention does not provide a

stepless adjustment of the ridge angle, the angle alternatives available are sufficient in practice. The basic construction of the plate heat exchanger composed of plates according to the invention is superior when compared with solutions of prior art where the ridge angle can be steplessly adjusted, at least
5 with respect to purchase price and reliability. The plate heat exchanger which is welded of plates according to the invention is small in size, reliable and provided with good pressure endurance features.

In the following, the plate heat exchanger according to the invention will be
10 described in more detail with reference to the appended drawings, in which

Fig. 1 is a schematical top view of the plate for a plate heat exchanger according to the invention,

15 Fig. 2 shows schematically an embodiment of the plate for a plate heat exchanger according to the invention, cut out from a flow opening of a larger plate,

Fig. 3 shows schematically how the plates for a plate heat exchanger
20 according to Fig. 1 are coupled together as plate pairs,

Fig. 4 shows schematically a plate heat exchanger composed of plates according to the invention cross-cut at the flow opening and the opened central hole,

25 Fig. 5 shows schematically a plate heat exchanger composed of plates according to the invention, seen at the unopened flow opening and unopened central hole,

In the following, the invention will be described in more detail with reference to the appended drawings. Figs. 1 to 3 show circular plates 1 for a plate heat exchanger, which plates 1 are made of a sheet material by means of a pressing tool. Corrugations 2 are pressed in the plate 1 by means of a pressing tool or the like. The locations 4, 5 for flow openings can be left unpunched at the pressing stage. In the middle of the plate 1 of the plate heat exchanger, it is possible to allocate a location 6 for the central hole. At the locations 4 and 5 of the flow openings as well as at the location 6 of the central hole, the corrugations 2 are cut, and at the outer perimeters of the openings there are straight, ring-like parts 7, 8, 9. The outer edges of the plate heat exchanger plates 1 are also provided with straight parts 10. In Fig. 3, the plates 1 are joined together in such a way that the ridges of the corrugations 12 form a ridge angle α with each other.

Figs 4 to 5 illustrate how the plates 1 of the plate heat exchanger are connected to each other. In the solution according to Fig. 4, the central hole 11 is opened. The plates 1 are joined together as plate pairs 13 at the outer perimeters of the flow openings 3 by means of welds 12. The plate pairs 13 are connected to each other at the outer perimeters of the plates 1 by means of a weld 14. Correspondingly, the opened central hole 11 is welded at its outer perimeter with a weld 15. The ring-like straight parts 10 at the outer perimeters of the plates 1 as well as the straight parts 9 of the central hole 11 are in the same plane, wherein the central hole 11 is connected to flow ducts 16, which open at the outer perimeter of the plates 1. Thus, it is possible to use the central hole 11 as an inlet or outlet passage for one flow circuit of heat transfer media. The flow openings 3 and the ducts 17 constitute a closed flow circuit, whose inlet and outlet passages are composed of the flow openings 3.

Fig. 5 illustrates how the unopened flow openings 3 and the central hole 11 affect the flow ducts 16 and 17. As can be seen in the figure, the flow ducts 16 and 17 remain open when meeting a location 4, 5 of the flow opening 3. However, the ring-like straight parts 9 of the unopened central hole 11 close one of the flow ducts 16, 17 when placed on top of each other, depending on the level at which the straight parts 9 are arranged. This fact has to be taken into account when using a plate heat exchanger composed of plates 1 according to the invention at high temperatures.

10 It is self-evident for anyone skilled in the art that the embodiment presented above is merely an embodiment according to the inventive idea, and it can naturally vary within the scope of protection determined in the claims. For example the profile of the corrugations 2 in the plate 1 for a plate heat exchanger can have any possible shape as long as it meets the strength and thermic requirements. When it is desired to make the gradation of the ridge angle α denser, the number of the locations 4, 5 of the flow openings 3 can be increased even so that they partly overlap each other. However, if the number of the locations 4, 5 is too large, the flow conditions in the ducts 16, 17 may change too much. The size of the central hole 11 and its coupling to the flow ducts 16, 17 can be selected according to the use.

15

20

Claims:

1. Plate for a plate heat exchanger, especially for welded plate heat exchangers, which plate separates flow ducts (16, 17) in a plate heat exchanger composed of plates, constitutes heat transfer surfaces for heat transfer media, has a circular shape and is provided with corrugations (2) or the like extending at least partly across the plate heat exchanger plate (1), **characterized** in that the plate (1) for a plate heat exchanger comprises at least two pairs of unopened locations (4, 5) for flow openings (3) in which locations (4, 5) the flow openings (3) can be made, and that by arranging the flow openings (3) in the desired locations (4, 5), the ridge angle α between the ridges of the corrugations (2) in adjacent plates (1) of a plate heat exchanger is adjusted to attain as good as possible flow and heat transfer characteristics.
2. Plate (1) for a plate heat exchanger according to claim 1, **characterized** in that in the centre of the plate (1) there is a location (6) for a central hole (11) which, when opened, in the plate heat exchanger composed of plates (1), forms a flow duct for the heat transfer medium and/or a duct in which the supporting means for the end plates of the heat exchanger is placed.
3. Plate (1) for a plate heat exchanger according to claims 1 to 2, **characterized** in that the locations (4, 5) for the flow openings (3) and the central hole (11) are composed of straight, ring-like parts (7, 8, 9) inside of which a part of the plate (1) comprises corrugations (2).
4. Plate (1) for a plate heat exchanger according to claims 1 to 3, **characterized** in that the locations (4, 5, 6) of the flow openings (3) and the central hole (11) constitute a part of the heat exchange surfaces in a plate heat exchanger composed of plates (1).

5 5. Plate (1) for a plate heat exchanger according to claims 1 to 4, **characterized** in that the ring-like straight part (10) of the outer perimeter of the plate (1), the ring-like straight parts (7, 8, 9) of the locations (4, 5, 6) of the flow openings (3) and the central hole (11) are on at least two different levels in order to close the flow ducts (16, 17) in a plate heat exchanger composed of plates (1).

10 6. Plate (1) for a plate heat exchanger according to claims 1 to 5, **characterized** in that in the plate heat exchanger composed of plates (1), the adjacent plates (1) are connected together at their outer perimeters as well as at the outer perimeters of the central holes (11) or the outer perimeters of the flow openings (3) by means of welding or a corresponding method.

15 7. Plate (1) for a plate heat exchanger according to claims 1 to 6, **characterized** in that the plate blanks removed from the flow openings (3) are plates (1) of a plate heat exchanger with a smaller diameter, containing alternative locations (4, 5) for the flow openings (3).

20 8. Plate (1) for a plate heat exchanger according to any of the foregoing claims, **characterized** in that the corrugations (2) of the plate (1) extend continuously through the centre of the plate (1) and that the plate (1) is not provided with location (6) for the central hole (11).

25 9. Plate heat exchanger composed of plates according to any of the claims 1 to 8, **characterized** in that in the plate heat exchanger composed of plates, adjacent plates (1) are connected together at their outer perimeters, as well as at the outer perimeters of the central holes (11) or at the outer perimeters of the flow openings (3) by means of welding or a corresponding method.

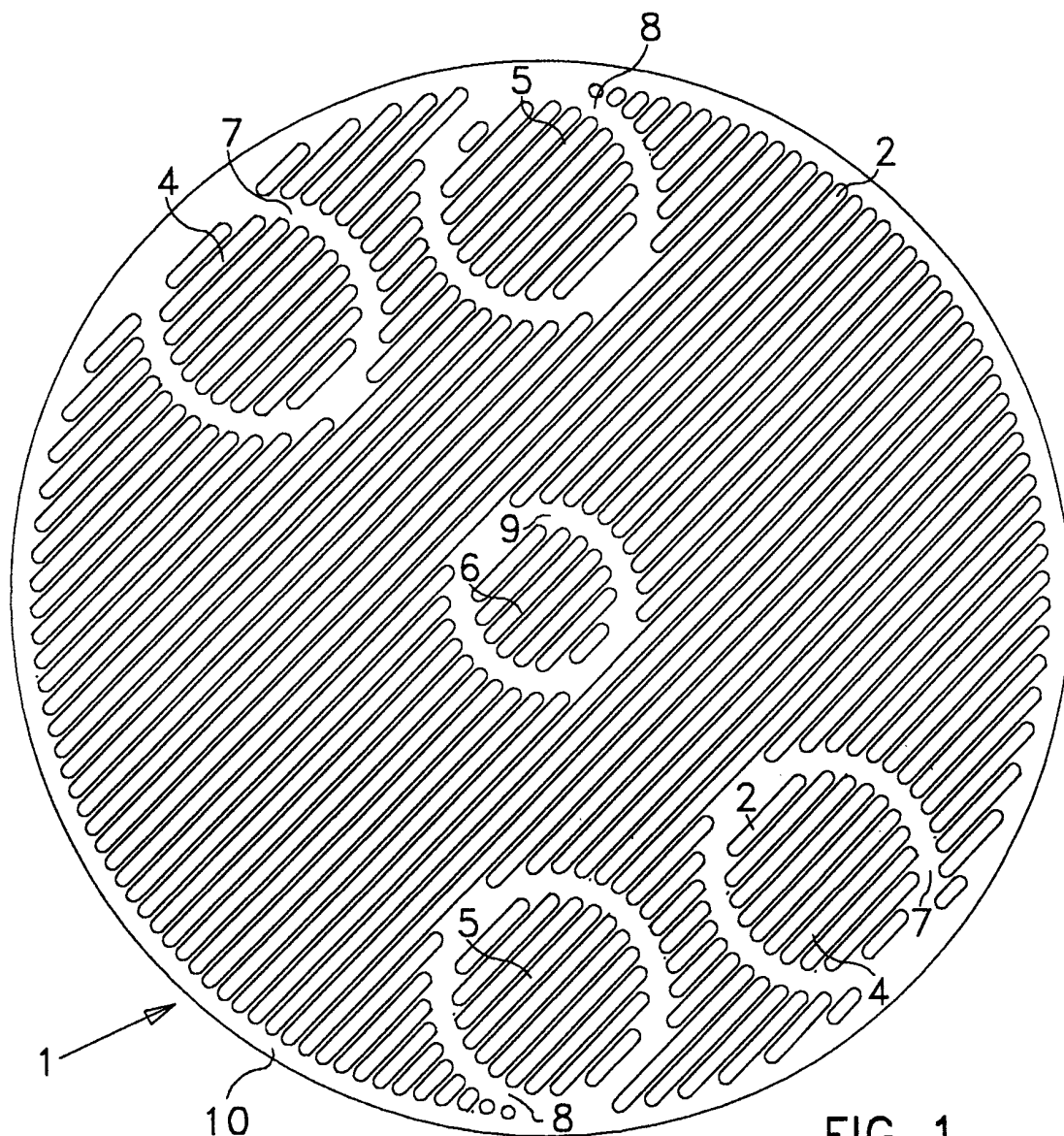

FIG 1

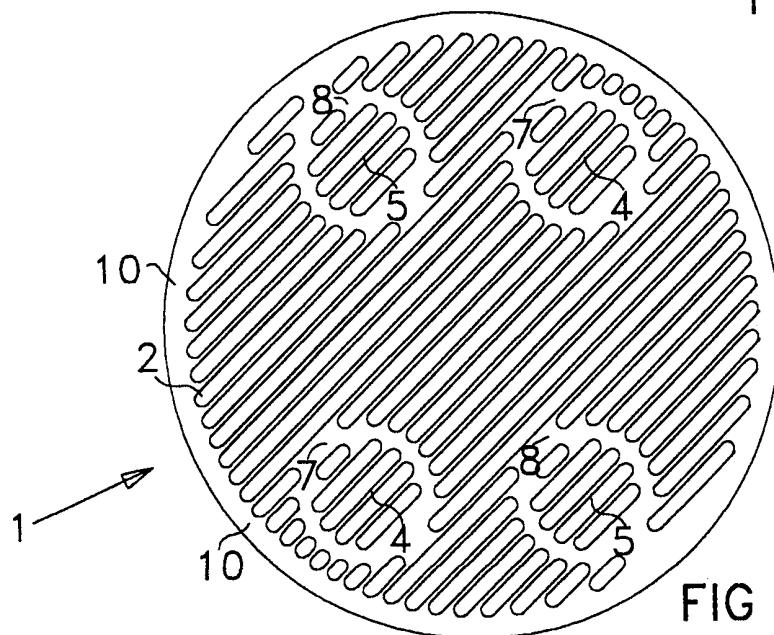

FIG 2

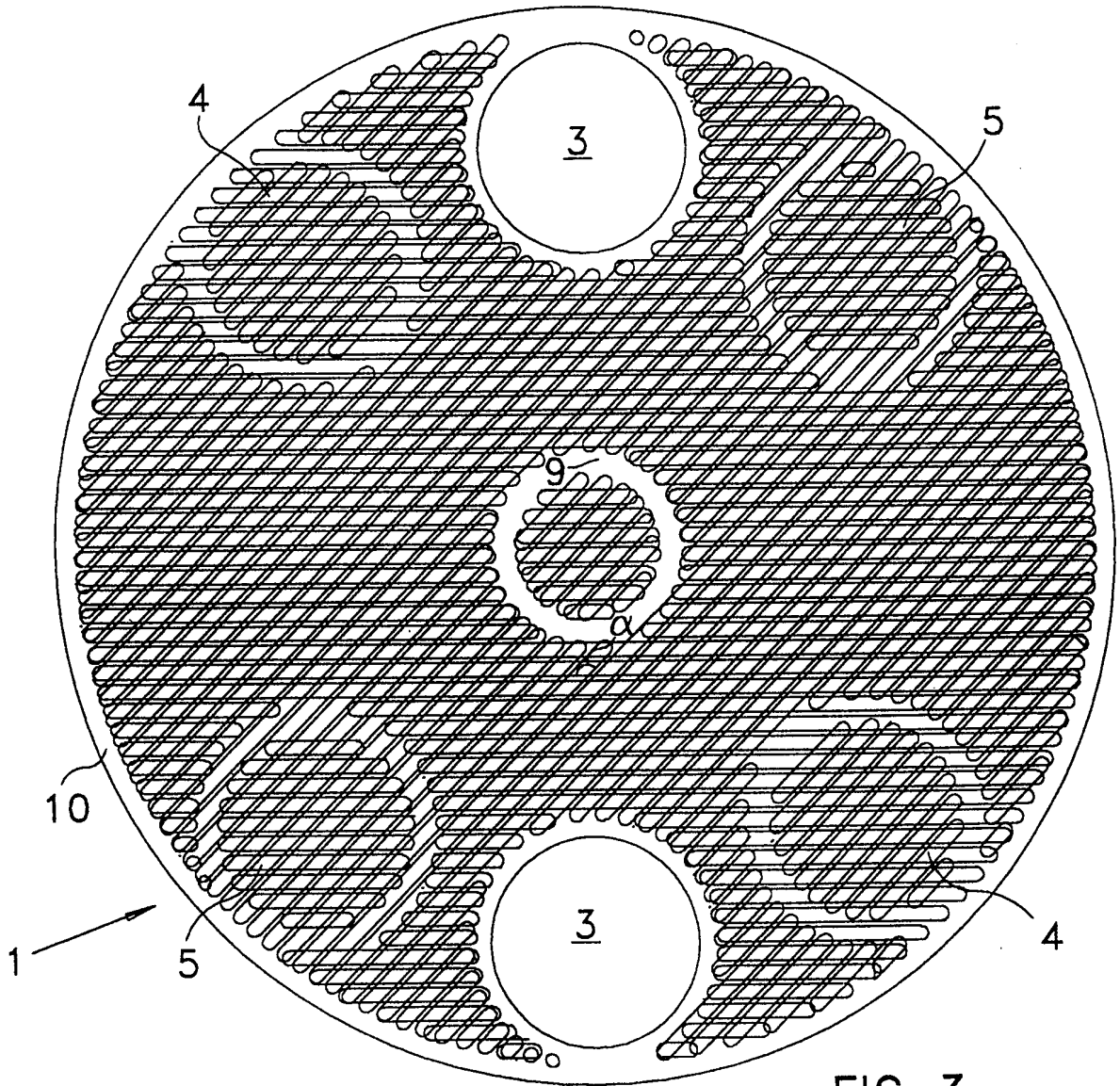

FIG 3

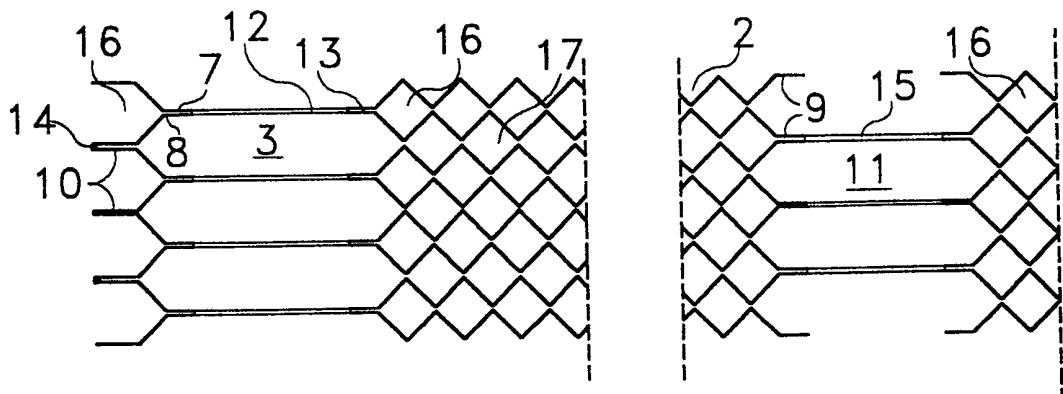

FIG 4

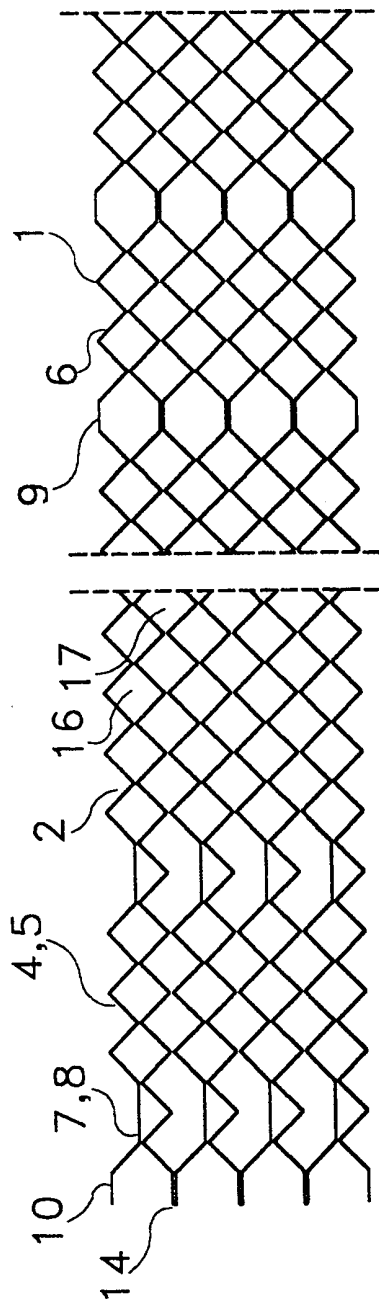

FIG 5

INTERNATIONAL SEARCH REPORT

International application No.

PCT/FI 99/00164

A. CLASSIFICATION OF SUBJECT MATTER

IPC6: F28F 3/08, B21D 53/04

According to International Patent Classification (IPC) or to both national classification and IPC

B. FIELDS SEARCHED

Minimum documentation searched (classification system followed by classification symbols)

IPC6: F28D, F28F, B21D

Documentation searched other than minimum documentation to the extent that such documents are included in the fields searched

SE,DK,FI,NO classes as above

Electronic data base consulted during the international search (name of data base and, where practicable, search terms used)

C. DOCUMENTS CONSIDERED TO BE RELEVANT

Category*	Citation of document, with indication, where appropriate, of the relevant passages	Relevant to claim No.
X	WO 9517272 A1 (KONTU, M.), 29 June 1995 (29.06.95), figure 7, claim 1 --	1,3-6,8,9
A	US 4987955 A (J.-O. BERGQVIST ET AL), 29 January 1991 (29.01.91), figure 3 --	3
A	JP 62202997 A (TSUCHIYA MFG CO LTD), 7 Sept 1987 (07.09.87), figures 1,5, detail (26) --	1,2,5
A	DE 2552335 A1 (VEB KOMBINAT IMPULSA BETRIEB VEB KYFFHÄUSERHÜTTE ARTERN), 8 June 1977 (08.06.77) --	



Further documents are listed in the continuation of Box C.



See patent family annex.

* Special categories of cited documents:

"A" document defining the general state of the art which is not considered to be of particular relevance

"E" earlier document but published on or after the international filing date

"L" document which may throw doubts on priority claim(s) or which is cited to establish the publication date of another citation or other special reason (as specified)

"O" document referring to an oral disclosure, use, exhibition or other means

"P" document published prior to the international filing date but later than the priority date claimed

"T" later document published after the international filing date or priority date and not in conflict with the application but cited to understand the principle or theory underlying the invention

"X" document of particular relevance: the claimed invention cannot be considered novel or cannot be considered to involve an inventive step when the document is taken alone

"Y" document of particular relevance: the claimed invention cannot be considered to involve an inventive step when the document is combined with one or more other such documents, such combination being obvious to a person skilled in the art

"&" document member of the same patent family

Date of the actual completion of the international search

21 June 1999

Date of mailing of the international search report

09.07.1999

Name and mailing address of the ISA/
Swedish Patent Office
Box 5055, S-102 42 STOCKHOLM
Facsimile No. +46 8 666 02 86

Authorized officer

Annette Riedel
Telephone No. +46 8 782 25 00

INTERNATIONAL SEARCH REPORT

International application No.

PCT/FI 99/00164

C (Continuation). DOCUMENTS CONSIDERED TO BE RELEVANT		
Category*	Citation of document, with indication, where appropriate, of the relevant passages	Relevant to claim No.
A	WO 9745689 A1 (NEK UMWELTTECHNIK AG), 4 December 1997 (04.12.97) --	
A	US 5088552 A (P. RAUNIO), 18 February 1992 (18.02.92) -- -----	

INTERNATIONAL SEARCH REPORT

Information on patent family members

01/06/99

International application No.

PCT/FI 99/00164

Patent document cited in search report	Publication date	Patent family member(s)	Publication date
WO 9517272 A1	29/06/95	AU 1244795 A EP 0735930 A FI 94395 B FI 935745 D JP 9506826 T US 5823253 A	10/07/95 09/10/96 31/05/95 00/00/00 08/07/97 20/10/98
US 4987955 A	29/01/91	AT 84140 T DE 3877215 A DK 9189 A DK 163897 B,C EP 0418227 A,B SE 0418227 T3 JP 2719380 B SE 458884 B,C SE 8702258 A WO 8809473 A	15/01/93 11/02/93 10/01/89 13/04/92 27/03/91 25/02/98 16/05/89 30/11/88 01/12/88
JP 62202997 A	07/09/87	JP 1692865 C JP 3004837 B	17/09/92 24/01/91
DE 2552335 A1	08/06/77	NONE	
WO 9745689 A1	04/12/97	EP 0901602 A	17/03/99
US 5088552 A	18/02/92	AT 82633 T AU 2079188 A DE 3876100 A DK 10090 A DK 167293 B EP 0375691 A,B SE 0375691 T3 FI 79409 B,C FI 873085 A JP 2504181 T JP 2582887 B SU 1823921 A WO 8900671 A	15/12/92 13/02/89 24/12/92 12/01/90 04/10/93 04/07/90 31/08/89 14/01/89 29/11/90 19/02/97 23/06/93 26/01/89