

*D. Arndt,
Mangle.*

No. 87,457.

Patented Mar. 2, 1869.

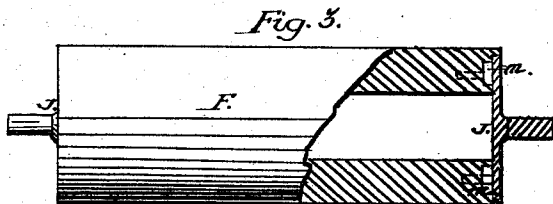
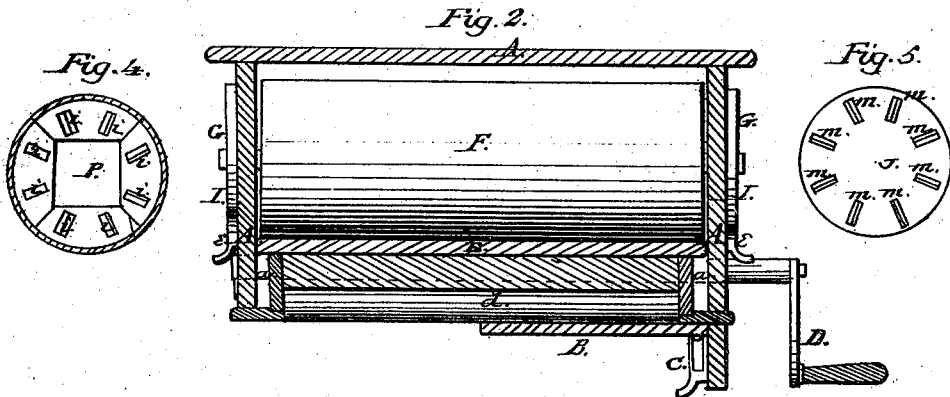
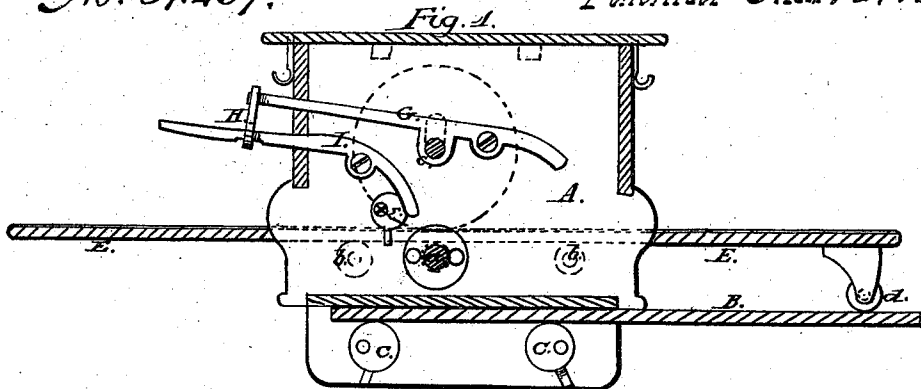

*Witnesses:
A. A. Steinhilber
Leopold Over*

*Inventor:
Daniel Arndt
Alexander Mason
Atty.*

United States Patent Office.

DANIEL ARNDT, OF TOLEDO, OHIO.

Letters Patent No. 87,457, dated March 2, 1869.

IMPROVED CLOTHES-MANGLE.

The Schedule referred to in these Letters Patent and making part of the same.

To all whom it may concern:

Be it known that I, DANIEL ARNDT, of Toledo, in the county of Lucas, and in the State of Ohio, have invented certain new and useful Improvements in Clothes-Mangles; and do hereby declare that the following is a full, clear, and exact description thereof, reference being had to the accompanying drawings, and to the letters of reference marked thereon.

The nature of my invention consists in the construction and arrangement of a "clothes-mangle," which will be hereinafter fully set forth.

In order to enable others skilled in the art to which my invention appertains, to make and use the same, I will now proceed to describe its construction and operation, referring to the annexed drawings, which form a part of this specification, and in which—

Figure 1 is a side view, and

Figure 2, a front view.

Figure 3 is a side view of the roller, part in section;

Figure 4 is an end view of the roller, the end-piece removed; and

Figure 5, view of the end-piece of the roller.

A represents the box in which the mangle is placed.

B, the table, to which said box is secured by means of two cam-wheels C C, as shown in fig. 1.

Near the bottom of the box is placed an iron roller, *a*, which has its bearing in the sides of the box, and is turned from the outside by a crank, D.

This roller *a* furnishes the motion to the mangle-board E, which rests on said roller, and is at one end provided with a small roller, *d*, on its under side, so as to allow the board to run level on the table.

The upper side of the mangle-board E is covered with cloth, so as to cause the clothes to pass under the large roller.

On each side of the iron roller *a*, is placed a roller,

b, which has its journal-bearings in the sides of the box A, and keeps the mangle board at all times level.

At a suitable distance above the iron roller *a*, is placed a large roller, F, the journals of which pass through vertical slots in the sides of the box A, and have their bearings in ears *c* on the levers G, pivoted, one on each side of the box.

A rubber band, or ring, H, connects each of the levers G with another lever, I, also pivoted to the side of the box A. The other end of the lever I is acted upon by a small cam, *e*, so that by the use of said cams, the large roller F can be made to press as hard as desired against the mangle-board.

The large roller F is made in sections, as shown in fig. 4, and the ends of such sections are provided with recesses *i i*.

At the ends are placed circular end-pieces J, which, on their inner side, are provided with projections *m m*, corresponding in size with the recesses *i i*.

When these end-pieces are placed in proper position, so that the projections *m m* fit into the recesses *i i*, the sections of the roller are held together. The end-pieces are then fastened by screws.

Having thus fully described my invention,

What I claim as new, and desire to secure by Letters Patent, is—

The combination of the large roller F, mangle-board E; and roller *d*, levers G G and I I, rubber bands H H, and cams *e e*, all constructed and arranged substantially as and for the purposes herein set forth.

In testimony that I claim the foregoing, I have hereunto set my hand, this 17th day of December, 1868.

DANIEL ARNDT.

Witnesses:

C. E. BLIVEN,
SAMUEL LEWIS.