

O. A. Bingham,
Manf. Chair Seats.
No. 102212. Patented Apr. 26. 1870.

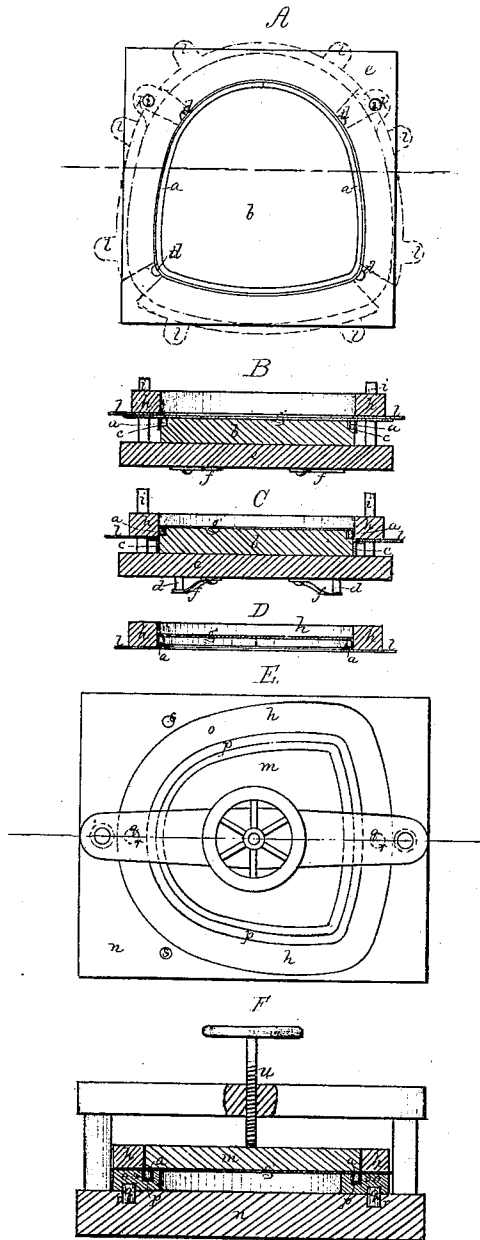

O. A. Bingham
by his attys
Crosby, Habited & Gould

Witness
L. B. Milder.
W. W. Frothingham

United States Patent Office.

OSMORE A. BINGHAM, OF CAVENDISH, VERMONT, ASSIGNOR TO GEORGE C. WINCHESTER, OF ASHBURNHAM, MASSACHUSETTS.

Letters Patent No. 102,212, dated April 26, 1870.

IMPROVED DEVICE FOR MANUFACTURING CHAIR SEATS.

The Schedule referred to in these Letters Patent and making part of the same.

To all whom it may concern:

Be it known that I, OSMORE A. BINGHAM, of Cavendish, in the county of Windsor and State of Vermont, have invented an Improvement in Applying Splints and Splint-retaining Strips to Chair-Seats; and I do hereby declare that the following, taken in connection with the drawings which accompany and form part of this specification, is a description of my invention sufficient to enable those skilled in the art to practice it.

My invention relates to the manufacture of that class of chair-seats in which the seating or webbing is stretched across an open seat-frame, as in ordinary cane-seat chairs, my improvement having particular reference to the process of attaching the webbing to the seat-frame by mechanical appliances, which render skilful manipulation unnecessary, and by which the webbing is stretched and secured very firmly and tightly upon the seat.

In carrying out my invention I use a chair-seat frame, which, being made in one piece, or of rails properly jointed or connected together, has a continuous groove sunk into and all around its top surface, this groove being formed to receive a continuous strip, around which the edges of the web are bent, and by which such edges are pressed into and confined in the groove, in such manner as to stretch the webbing and hold it taut over the open frame, the edges of the web being bent over and covering the strip, substantially as shown in the United States Patent No. 94,553, granted to me September 1, 1869.

My present invention will be described by reference to the accompanying drawing, in which—

A shows in plan a former, to which the retaining-strip is first applied.

B shows a section of such former, and a strip-encompassing hoop placed on top thereof.

C is a similar section, excepting that the hoop is pressed down.

D shows a section of the hoop raised from the frame, taking with it the web-retaining strip.

E is a top view of the press, by which the strip is transferred from the hoop to the chair-seat groove, and the grooved seat in position to receive the web.

F is a section of the press and seat-frame. These views, A B C D E F, representing the successive steps in the process of applying the webbing and web-retaining strip to the chair-seat frame.

a denotes the retaining strip, preferably made of wood, by means of which the edge of the seating is to be plugged in the chair-seat groove, and thereby confined to the seat.

This strip having been cut to the proper length, width, and thickness, *i. e.*, to a length corresponding

to the length of the chair-seat groove, and to a width and thickness corresponding to or slightly less than the depth and width of the groove, is steamed and bent around a former or block, *b*, the outer edge or perimenter of which corresponds to the inner wall of the chair-seat groove, the strip being retained against the edge of the former by a band, *c*, encompassing the former, this band being fixed to pins *d*, which extending through a base, *e*, rest upon springs *f*; such springs holding the band normally in the position shown at B, around the strip *a*, but enabling it to be pressed down below such strip.

The strip being thus formed and placed within the band *c*, between it and the former *b*, as seen at A and B, I next lay over the former the web *g*, to be fastened by the strip, this web being formed of woven strips or splints, or of any other suitable chair-seating material, the edges of the web extending some distance beyond the band. I then lay over the web an open frame, *h*, the opening through which corresponds in size and form to the outer surface of the strip *a*, guide pins *i*, and holes *k*, determining the position of the frame, so that when it is pressed down it shall surround the strip *a*. As it is pressed down, it comes upon the web and directly over the top of the band *c*, pushing down said band, and pressing the edges of the web down against the sides of the strip *a*.

When the strip is released from the band, by descent of the band below the strip, the expansion of the strip carries it outwardly against the inner wall of the frame, so that, when the frame is next raised, the strip and web come with it, being held by friction and the spring of the strip.

Slides *l* are then pressed inwardly, to bend the edges of the webbing under the strip, the edges being trimmed off, as may be necessary, and the slides being drawn back and leaving the web-edges turned inward.

The frame *h* is considerably thicker than the depth of the strip, and into the opening of the frame a block or platen, *m*, fits, said block resting upon the top of the webbing and strip.

The strip and web-receiving frame are now carried to the press for the final operation, *n* representing the bed of the press, upon which is placed the seat-frame *o*, in the top of which is made the continuous strip-receiving groove *p*, this frame being brought to proper position by two pins *q* projecting up from the bed, entering holes *r*, in the bottom of the frame.

The seat-frame *o* being placed upon the bed, the frame *h* is laid over it, and is positioned relatively to the seat-frame by pins *s*, on the bed, and the holes *k*, through the frame *h*, such positioning bringing the

strip contained in the frame *h* in exact position over the groove in the chair-seat frame *o*.

The platen *m* being placed in the frame *h*, the press-screw *u* is forced down, carrying with it the platen, said platen forcing the strip *a*, and with it the web drawn over its edges, down into the groove in the chair-seat frame, the strip and web fitting tightly into the groove, so that when the screw is raised, and the platen *m*, frame *h*, and seat-frame are all removed, the webbing will be found stretched tightly over the opening through the seat-frame, and firmly fixed to said frame by the strip and groove, the webbing extending over the strip and groove so as to entirely conceal them.

It will readily be seen that in practice this whole operation, or series of operations, may be performed

with the greatest ease and expedition, effecting a great saving of time, and making much better work than can possibly be accomplished by hand, without the aid of such mechanism.

I claim—

The devices by which the web *g* is applied to the strip *a*, consisting of the former *b*, band *c*, and frame *h*, arranged and operating substantially as described.

Also, in combination with the above, the devices for applying the strip *a* and web *g* to the seat-frame, consisting of the bed *n*, plate *m*, and press-screw *u*, substantially as shown and described.

O. A. BINGHAM.

Witnesses:

J. B. CROSBY,
FRANCIS GOULD.