



(51) International Patent Classification:

F21K 9/20 (2016.01) *F21V 23/04* (2006.01)
F21V 5/04 (2006.01) *F21Y 115/10* (2016.01)
F21V 17/12 (2006.01)

(21) International Application Number:

PCT/CN2017/091938

(22) International Filing Date:

06 July 2017 (06.07.2017)

(25) Filing Language:

English

(26) Publication Language:

English

(30) Priority Data:

201611206980.6 23 December 2016 (23.12.2016) CN

(71) Applicant: **ZHEJIANG SHENGHUI LIGHTING CO., LTD.** [CN/CN]; West Jiachuang Road, Xiuzhou Industrial Park, Jiaxing, Zhejiang 314015 (CN).

(72) Inventors: **WAN, Yehua**; No. 39 Shenghui Road, Xiuzhou District, Jiaxing, Zhejiang 314031 (CN). **GE, Xuchu**; No. 39 Shenghui Road, Xiuzhou District, Jiaxing, Zhejiang 314031 (CN). **SHEN, Jinxiang**; No. 39 Shenghui Road, Xiuzhou District, Jiaxing, Zhejiang 314031 (CN).

(74) Agent: **LEADER PATENT & TRADEMARK FIRM**; 8F-6, Bldg. A, Winland International Center, No. 32 Xizhimen North Street, Haidian District, Beijing 100082 (CN).

(81) Designated States (*unless otherwise indicated, for every kind of national protection available*): AE, AG, AL, AM, AO, AT, AU, AZ, BA, BB, BG, BH, BN, BR, BW, BY, BZ, CA, CH, CL, CN, CO, CR, CU, CZ, DE, DJ, DK, DM, DO, DZ, EC, EE, EG, ES, FI, GB, GD, GE, GH, GM, GT, HN, HR, HU, ID, IL, IN, IR, IS, JO, JP, KE, KG, KH, KN, KP, KR, KW, KZ, LA, LC, LK, LR, LS, LU, LY, MA, MD, ME, MG, MK, MN, MW, MX, MY, MZ, NA, NG, NI, NO, NZ, OM, PA, PE, PG, PH, PL, PT, QA, RO, RS, RU, RW, SA, SC, SD, SE, SG, SK, SL, SM, ST, SV, SY, TH, TJ, TM, TN, TR, TT, TZ, UA, UG, US, UZ, VC, VN, ZA, ZM, ZW.

(84) Designated States (*unless otherwise indicated, for every kind of regional protection available*): ARIPO (BW, GH, GM, KE, LR, LS, MW, MZ, NA, RW, SD, SL, ST, SZ, TZ, UG, ZM, ZW), Eurasian (AM, AZ, BY, KG, KZ, RU, TJ, TM), European (AL, AT, BE, BG, CH, CY, CZ, DE, DK, EE, ES, FI, FR, GB, GR, HR, HU, IE, IS, IT, LT, LU, LV, MC, MK, MT, NL, NO, PL, PT, RO, RS, SE, SI, SK, SM, TR), OAPI (BF, BJ, CF, CG, CI, CM, GA, GN, GQ, GW, KM, ML, MR, NE, SN, TD, TG).

(54) Title: A SENSOR LIGHT AND A SYSTEM FOR PREVENTING FALSE TRIGGERING OF A SENSOR

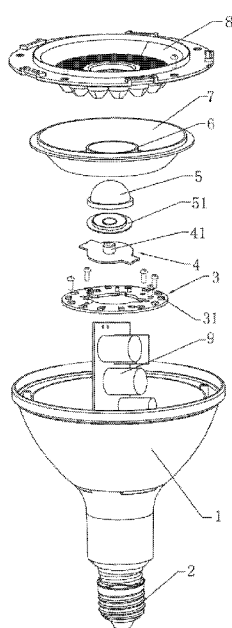

FIG. 1

(57) Abstract: A sensor light and a system prevent false triggering of a sensor. The sensor light includes a sensor module (4), a light emitting module (3), a power drive circuit (9), and a shielding component (6). The sensor module (4) is configured to measure incoming infrared light radiated to the sensor module (4), and generate a trigger signal when the measured infrared light meets a preset condition. The light emitting module (3) is configured to emit light. The power drive circuit (9) is connected to the sensor module (4) and the light emitting module (3), and configured to receive the trigger signal from the sensor module (4), and control the light emitting module (3) to emit light in response to the trigger signal. The shielding component (6) is disposed between the sensor module (4) and the light emitting module (3), and configured to shield the sensor module (4) from radiation of infrared light generated by the light emitting module (3).



Published:

— *with international search report (Art. 21(3))*

A SENSOR LIGHT AND A SYSTEM FOR PREVENTING FALSE TRIGGERING OF A SENSOR

CROSS-REFERENCES TO RELATED APPLICATIONS

[0001] This application claims the priority of Chinese Patent Application No. 5 201611206980.6, entitled “A SENSOR LIGHT AND A SYSTEM FOR PREVENTING FALSE TRIGGERING OF A SENSOR,” filed on December 23, 2016, the entire contents of which are incorporated herein by reference.

FIELD OF THE DISCLOSURE

[0002] The present disclosure relates to the field of lighting technologies and, more 10 particularly, relates to a sensor light and a system for preventing false triggering of a sensor.

BACKGROUND

[0003] Human body sensor light or sensor module light is a technological product designed and developed based on infrared and pyroelectric principles for detecting and sensing human activities. In existing LED sensor lights, because an LED illumination module can dissipate 15 heat and can remain at a relative high temperature after stopping emitting light, the LED illumination module may also generate infrared rays. Such infrared rays may be detected by an embedded passive infrared (PIR) sensor of the sensor light and falsely trigger the sensor light to be turned on.

[0004] The disclosed method and system are directed to solve one or more problems set forth 20 above and other problems.

BRIEF SUMMARY OF THE DISCLOSURE

[0005] One aspect of the present disclosure provides a sensor light, including a sensor 25 module, a light emitting module, a power drive circuit, and a shielding component. The sensor module is configured to measure incoming infrared light radiated to the sensor module, and generate a trigger signal when the measured infrared light meets a preset condition. The

light emitting module is configured to emit light. The power drive circuit is connected to the sensor module and the light emitting module, and is configured to receive the trigger signal from the sensor module, and control the light emitting module to emit light in response to the trigger signal received from the sensor module. The shielding component is disposed
5 between the sensor module and the light emitting module, and configured to shield the sensor module from radiation of infrared light generated by the light emitting module.

[0006] By introducing the shielding component to the sensor light, false triggering of the sensor module, especially a false triggering caused by heat dissipation from the light emitting module, can be prevented.

10 [0007] Optionally, the shielding component originates at a same or lower horizontal level than the sensor module, and surrounds a side of the sensor module. A highest horizontal level of the shielding component is greater than a highest horizontal level of the light emitting module. A horizontal level refers to a level of a plane perpendicular to an axis direction of the sensor light.

15 [0008] Optionally, the highest horizontal level of the shielding component is greater than a highest horizontal level of the sensor module.

[0009] Optionally, the sensor light further includes a Fresnel lens configured to cover the sensor module and concentrate the incoming infrared light for the sensor module, wherein the light emitting module is located outside the Fresnel lens.

20 [0010] Optionally, the highest horizontal level of the shielding component is no greater than a highest horizontal level of the Fresnel lens.

[0011] Optionally, the shielding component is covered by the Fresnel lens.

[0012] Optionally, the shielding component surrounds an outside of the Fresnel lens.

[0013] Optionally, the shielding component includes a first layer and a second layer; the first
25 layer of the shielding component is covered by the Fresnel lens; and the second layer of the shielding component surrounds a side of the Fresnel lens.

[0014] Optionally, the shielding component has a single layer structure or includes multiple layers.

[0015] Optionally, the shielding component includes a vertical wall or a slanted wall.

30 [0016] Optionally, a top end of the shielding component is open; and a cross section of the shielding component has a circular shape, an eclipse shape, or a rectangular shape.

[0017] Optionally, the sensor module is disposed on a center of a substrate of the light emitting module; the light emitting module includes a plurality of LED light emitters

scattered around the center of the substrate of the light emitting module; and a lens holder is disposed on a substrate of the sensor module for mounting the Fresnel lens.

[0018] Optionally, a material of the shielding component is non-polyolefin.

5 [0019] Optionally, a thickness of the shielding component and a distance between the shielding component and the light emitting module is determined based on a lighting intensity of the light emitting module.

[0020] Optionally, a height of the shielding component is determined based on a lighting intensity of the light emitting module, the highest horizontal level of the light emitting module, a location of the sensor module, and the highest horizontal level of the sensor
10 module.

[0021] Optionally, a slanted degree of the shielding component corresponds to a lighting intensity of the light emitting module, a location of the sensor module, and the highest horizontal level of the sensor module.

[0022] Optionally, the sensor light further includes: a housing including an opening top part and a bottom part, a lamp holder for connecting to the bottom part of the housing, a reflector, and an optical lens structure. Further, the sensor module, the light emitting module, and the power drive circuit are installed in the housing through the opening top part. The reflector and the optical lens structure are sequentially disposed at the opening top part. The optical lens structure has a compatible shape for covering the opening top part of the housing.
15

[0023] Optionally, an inner edge of the top opening part includes a first mounting structure and a second mounting structure, the first mounting structure being closer to a top end of the housing than the second mounting structure; the optical lens structure is mounted on the first mounting structure by a first fastening piece; and the light emitting module is mounted on the second mounting structure by a second fastening piece.
20

[0024] Another aspect of the present disclosure provides a system for preventing false triggering of a sensor. The system includes a sensor module and a shielding component. The sensor module is configured to measure incoming infrared light radiated to the sensor module, and generate a trigger signal when the measured infrared light satisfies a preset condition; and the shielding component is located between the sensor module and a heat dissipation source, and configured to shield the sensor module from radiation of infrared light generated by the
25
30 heat dissipation source.

[0025] Optionally, the shielding component originates at a same or lower horizontal level than the sensor module, and surrounds a side of the sensor module; and the highest horizontal

level of the shielding component is greater than a highest horizontal level of the heat dissipation source.

[0026] Optionally, the system further includes a Fresnel lens configured to cover the sensor module and concentrate the incoming infrared light for the sensor module. Further, the highest horizontal level of the shielding component is no greater than a highest horizontal level of the Fresnel lens.

[0027] Optionally, the shielding component includes at least one of: a first layer covered by the Fresnel lens, or a second layer surrounding a side of the Fresnel lens.

[0028] Other aspects of the present disclosure can be understood by those skilled in the art in light of the description, the claims, and the drawings of the present disclosure.

[0029] By implementing the disclosed sensor light or the disclosed system, the shielding component can reduce or prevent infrared radiation from a heat dissipation source to the sensor module, thereby preventing false triggering of the sensor, especially a false triggering caused by heat dissipation from the light emitting module.

BRIEF DESCRIPTION OF THE DRAWINGS

[0030] The following drawings are merely examples for illustrative purposes according to various disclosed embodiments and are not intended to limit the scope of the present disclosure.

[0031] FIG. 1 is an exploded view of an exemplary sensor light consistent with the disclosed embodiments;

[0032] FIG. 2 is a structural diagram of an exemplary sensor light consistent with the disclosed embodiments;

[0033] FIG. 3 is a schematic view of a light emitting module, a sensor module, a Fresnel lens, a shielding component, a reflector, and an optical lens structure coordinated with each other consistent with the disclosed embodiments;

[0034] FIG. 4 is a side-view of a light emitting module, a sensor module, a Fresnel lens, a shielding component, a reflector, and an optical lens structure coordinated with each other consistent with the disclosed embodiments;

[0035] FIG. 5 is a structural diagram of an exemplary optical lens structure consistent with the disclosed embodiments;

[0036] FIG. 6 is a schematic view of a light emitting module, a sensor module, a Fresnel lens, a shielding component, and a reflector coordinated with each other consistent with the disclosed embodiments;

5 [0037] FIG. 7 is another schematic view of a light emitting module, a sensor module, a Fresnel lens, a shielding component, and a reflector coordinated with each other consistent with the disclosed embodiments;

[0038] FIG. 8 is a schematic view of an exemplary way for placing a shielding component consistent with the disclosed embodiments;

10 [0039] FIG. 9 is a schematic view of another exemplary way for placing a shielding component consistent with the disclosed embodiments;

[0040] FIG. 10 is a schematic view of yet another exemplary way for placing a shielding component consistent with the disclosed embodiments;

[0041] FIG. 11 is a schematic view of an exemplary shielding component placed inside the Fresnel lens consistent with the disclosed embodiments; and

15 [0042] FIG. 12 is a schematic view of an exemplary shielding component placed outside the Fresnel lens consistent with the disclosed embodiments.

DETAILED DESCRIPTION

[0043] Reference will now be made in detail to exemplary embodiments of the invention, which are illustrated in the accompanying drawings. Hereinafter, embodiments consistent with the disclosure will be described with reference to the drawings. Wherever possible, the same reference numbers will be used throughout the drawings to refer to the same or like parts. It is apparent that the described embodiments are some but not all of the embodiments of the present invention. Based on the disclosed embodiments, persons of ordinary skill in the art may derive other embodiments consistent with the present disclosure, all of which are within the scope of the present invention.

20 [0044] The present disclosure provides a sensor light (e.g., LED illumination lamp) including a sensor module. When a person or an object with warm temperature enters a sensing range of the sensor module, the sensor module may output a high-level pulse signal, or a high-level delay signal. The outputted pulse signal or delay signal can directly drive the sensor light (e.g., by triggering a power drive circuit to control a light emitting module to emit light). The sensor light can be automatically turned on when a person is in the proximity of the light, and can be automatically turned off at a delayed time. The sensor light can prevent man-made

30

energy waste, extend the life of electrical appliances, and provide convenient security capabilities.

[0045] In an exemplary embodiment, a working principle of the disclosed sensor light includes that: infrared rays from a human body or other objects is detected by a sensor module including a passive infrared (PIR) sensor. The sensor module accordingly provides a trigger signal to a driver circuit for lighting an illumination module (e.g., LED light emitter). Further, the infrared rays may be refracted by a Fresnel lens before being incident on the PIR sensor.

[0046] In the disclosed embodiments, referring to FIG. 1, directions are defined based on a reversely-placed lamp. A light socket (i.e., lamp holder 2) of the sensor light is considered as at the bottom of the sensor light.

[0047] Referring to FIGS. 1-7, an exemplary sensor light is shown. The sensor light may include a housing 1, a power drive circuit 9, an interference reduction structure, a reflector 7, and an optical lens structure 8. Certain components may be omitted and certain components may be added.

[0048] A bottom part of the housing 1 may be compatible with and connected to a light socket 2 (e.g., by threaded connection). A top part of the housing 1 may include a top opening having a greater diameter than the bottom part. The diameter of the top part of the housing 1 may gradually decrease downwardly from the top opening to a portion connecting with the bottom part. The power drive circuit 9 and the interference reduction structure may be disposed in an installation space provided by the housing 1 (e.g., a cavity of the housing 1 through the top opening). The power drive circuit 9 may be electrically connected to the interference prevention structure. The reflector 7 and the optical lens structure 8 may be sequentially placed at the top opening of the housing 1. The reflector 7 may have a trumpet shape compatible with the shape of corresponding portion of the housing 1.

[0049] The interference reduction structure may include a light emitting module 3 (i.e., light illumination module), a sensor module 4, and a shielding component 6 (i.e., shielding member). The driver circuit 9 is electrically connected to the light emitting module 3 and the sensor module 4. The sensor module 4 may be configured to measure incident infrared light radiated to the sensor module 4, and provide a trigger signal to the power drive circuit 9 when the measured infrared light meets a preset condition. The sensor module 4 may include an infrared sensor (e.g., PIR sensor) disposed on a corresponding substrate. The power drive circuit 9 may be configured to control the light emitting module 3 to emit light (e.g., for providing general lighting to a surrounding indoor/outdoor space) in response to the received

trigger signal. The light emitting module 3 may include one or more LED light emitters 31 disposed on a corresponding substrate. The LED light emitters 31 are electrically connected to the power drive circuit 9. The shielding component 6 may be placed between the sensor module 4 and the light emitting module 3, and configured to reduce or prevent infrared lights of the light emitting module 3 from radiating to the sensor module 4, and thereby preventing false triggering. The shielding component 6 may be made of non-polyolefin material.

[0050] An inner edge near the top opening of the housing 1 may include a first mounting structure and a second mounting structure. Both mounting structures may have an annular shape or other suitable shapes. The first mounting structure is a layer closer to the top opening of the housing 1 than the second mounting structure. The substrate of the light emitting module 3 may be mounted on and fixed to the second mounting structure (e.g., by screws). The substrate of the light emitting module 3 may be substantially circular. A substrate of the sensor module 4 may be placed on top of a center part of the light emitting module 3 (e.g., by fitting a concentric hole of a ring-shaped substrate of the light emitting module 3). The center of the substrate of the light emitting module 3 and the substrate of the sensor module 4 may have compatible shapes and arrangements. Further, the LED light emitter 31 may be scattered around the center of the light emitting module 3. That is, the LED light emitters 31 may be arranged around the sensor module 4.

[0051] As shown in FIG. 6, the reflector 7 may be mounted on and surround the light emitting module 3. As shown in FIG. 3, the optical lens structure 8 may be mounted on the first mounting structure and press down the reflector 7 firmly, so that the reflector 7 do not shake. That is, the bottom rim of the reflector 7 may contact the substrate of the light emitting module 3 and/or the second mounting structure of the housing 1. The top rim of the reflector 7 may contact the optical lens structure 8 and/or the first mounting structure of the housing 1. The reflector 7 surrounding the light emitting module 3 may be configured to reflect the light emitted by the LED light emitters 31. The optical lens structure 8 may be configured to expand lighting emitting angles, adjust illumination distribution, and enhance light intensity. FIG. 5 is a structural diagram of an exemplary optical lens structure consistent with the disclosed embodiments. The reflector 7 and the optical lens structure 8 may adopt any proper structures or configurations in LED lighting technologies for concentrating the emitted light and enhancing light intensity.

[0052] As shown in FIG. 4 and FIG. 6, after installation, the light emitting module 3 may be located at an opening of a bottom end of the reflector 7. The substrate of the light emitting module 3 may close the opening of the bottom end of the reflector 7.

[0053] In some embodiments, as shown in FIGS. 1 and 2, the interference reduction structure may further include a Fresnel lens 5. The Fresnel lens 5 may be configured to cover the sensor module 4 and concentrate/focus the incident infrared lights for the sensor module 4. The LED light emitters 31 may be placed outside the Fresnel lens 5. As shown in FIG. 5, a lens holder 51 for fixating the Fresnel lens 5 may be disposed at a center of a top surface of the substrate of the sensor module 4. The Fresnel lens 5 may be mounted and fixed on the lens holder 51 by snap fit or interference fit. Any proper fixation method may be used to install the Fresnel lens 5.

[0054] In one embodiment, as shown in FIGS. 3 and 4, an infrared sensor 41 may be configured at the center of the substrate of the sensor module 4. The infrared sensor 41 may have a cylindrical shape. The center of the lens holder 51 may include a circular through-hole having a diameter compatible with a diameter of the infrared sensor 41. The lens holder 51 may be placed on the substrate of the sensor module 4 with the infrared sensor 41 passing through the through-hole of the lens holder 51 accordingly. In other words, the infrared sensor 41 is inserted through the through-hole of the lens holder 51. Accordingly, the lens holder 51 may be firmly fixed on the substrate of the sensor module 4, thereby preventing shakings.

[0055] The shielding component 6 may be configured in any proper ways. In one example, the shielding component 6 may be placed inside the Fresnel lens 5 and covered by the Fresnel lens 5 (e.g., as shown in FIGS. 8 and 11). In another example, the shielding component 6 may be placed outside the Fresnel lens 5, and surrounds the Fresnel lens 5 (e.g., as shown in FIGS. 6, 7, and 9). The shielding component 6 may tightly wrap the Fresnel lens 5, or may be placed at a preset interval with the Fresnel lens 5. The sensitivity for measuring infrared variations of the outer environment of the sensor module 4 may not be effected by the shielding component 6. In yet another example, the shielding component 6 may include a first shielding member 6a and a second shielding member 6b (e.g., as shown in FIG. 10). The first shielding member 6a may be covered by the Fresnel lens 5, and the second shielding member 6b may surround an outside of the Fresnel lens 5. In some embodiments, the shielding component 6 may be mounted inside the reflector 7, as shown in FIG. 1.

[0056] In an exemplary embodiment, the highest horizontal level of the shielding component 6 is no greater than a highest horizontal level of the Fresnel lens 5. As used herein, a horizontal level refers to a surface level perpendicular to an axis of the sensor light. A higher horizontal level refers to a surface level farther away from the lamp holder 2. Further, the

highest horizontal level of the shielding component 6 may be higher or lower than the top end of the infrared sensor 41.

[0057] In an exemplary embodiment, a bottom end of the shielding component 6 may be at a same or lower horizontal level of the LED light emitters 31, and a top end of the shielding component 6 may be at a same or higher level of the light emitting module 3. A thickness of the shielding component and a location of the shielding component (e.g., a distance to the light emitting module 3, a distance to the sensor module 4 or Fresnel lens 5) may be determined based on a lighting intensity of the light emitting module 3. Further, the highest horizontal level of the shielding component 6 (e.g., a height of the shielding component 6 when the bottom end of the shielding component 6 is located at a same horizontal level) may be determined based on light intensity of the light emitting module 3, the location of the shielding component (e.g., a distance from the light emitting module 3, or a distance from the sensor module 4), the highest horizontal level of the light emitting module 3, and/or the highest horizontal level of the sensor module 4 or the Fresnel lens 5. For example, as the light intensity of the light emitting module 3 increases, the top end of the shielding component 6 may be configured at a higher horizontal level. As the distance between the shielding component 6 and the light emitting module 3 decreases, the top end of the shielding component 6 may be configured at a lower horizontal level. As the highest horizontal level of the light emitting module 3 increases, the top end of the shielding component 6 may be configured at a higher horizontal level.

[0058] In some embodiments, the top end of the shielding component 6 is open. A shape of a cross section of the shielding component 6 may be circle, eclipse, ring, or rectangle (e.g., as shown in FIG. 12). In some embodiments, the shielding component 6a may have a different shape than the shielding component 6b.

[0059] In some embodiments, the shielding component 6 may have a single layer structure or may include multiple layers. For example, as shown in FIG. 6, the shielding component 6 may include a first ring layer 6c contacting the substrate of the light emitting module 3, and a second ring layer 6d placed on top of the first ring layer 6c for providing shield with greater height.

[0060] In some embodiments, the shielding component 6 may generally have a wall shape. The shielding component 6 may include one or more layers of wall (e.g., at different distances from the center point of the sensor module 4). The wall may have uniform thickness or uneven thickness (e.g., gradually thicker from top to bottom). The wall may be a continuous ring-shaped wall concentric with the sensor module 4. Alternatively, the wall

may be formed by discrete pieces of wall components. The wall components may be connected by contacting each other or may be placed at certain intervals. The wall components may have uniform heights or different heights.

[0061] In one embodiment, one side of the wall of the shielding component 6 may be vertical.

5 The highest horizontal level of the shielding component 6 may be determined based on light intensity of the light emitting module 3, a distance between the shielding component 6 and the light emitting module 3, and the highest horizontal level of the light emitting module 3.

[0062] In another embodiment, one side of the wall of the shielding component 6 may be slanted (e.g., the side facing the light emitting module 3 and outer shell of the housing 1). A

10 top end of the wall may lean forward to the LED light emitters 31. In other words, a horizontal distance between the top end of the wall and the LED light emitter 31 is smaller than that between the bottom end of the wall and the LED light emitter 31.

[0063] Further, when the inclination of the wall (i.e., a slanted degree, or an angle between the horizontal plane and the slanted side of the wall) is set, the height of the wall may be

15 determined based on the light intensity of the light emitting module 3, the distance between the shielding component 6 and the light emitting module 3, and the highest horizontal level of the light emitting module 3. When the height of the wall is set and the wall has a uniform thickness, the inclination of the wall may be determined based on the light intensity of the light emitting module 3, the distance between the shielding component 6 and the sensor

20 module 4, and the highest horizontal level of the sensor module 4. For example, as the light intensity of the light emitting module 3 increases, or as highest horizontal level of the sensor module 4 increases, the inclination of the shielding component 6 may be configured to have a greater value.

[0064] In yet another embodiment, one side of the wall of the shielding component 6 may be

25 slanted, and the top end of the wall may lean backward against the LED light emitters 31. In other words, a horizontal distance between the top end of the wall and the LED light emitter 31 is greater than that between the bottom end of the wall and the LED light emitter 31.

When the height of the wall is set and the wall has a uniform thickness, the inclination of the wall may be determined based on the light intensity of the light emitting module 3, the

30 distance between the shielding component 6 and the sensor module 4, and the highest horizontal level of the sensor module 4. For example, as the light intensity of the light emitting module 3 increases, or as highest horizontal level of the sensor module 4 increases, the inclination of the shielding component 6 may be configured to have a smaller value.

[0065] In some embodiments, the light emitting module 3 (e.g., LED light emitter 31) and the sensor module 4 may be disposed at different sides of the shielding component 6. Specifically, the bottom end of the shielding component 6 may be at a same or lower horizontal level than that of the sensor module 4; and the top end of the shielding component 6 may be at a same or higher horizontal level than that of the light emitting module 3.

[0066] The present disclosure further provides a system for preventing false triggering of a sensor module. Referring to FIGS. 8-10, an exemplary system may include a sensor module 4, and a shielding component 6. The system may prevent infrared lights generated by a heat dissipation source 10 from interfering with the sensor module 4. The sensor module 4 may be configured to measure incident infrared light radiated to the sensor module 4, and generate a trigger signal when the measured infrared light meets a preset condition (e.g., measured infrared light reaches a preset threshold). The shielding component 6 may be disposed between the sensor module and the heat dissipation source 10, and configured to shield the sensor module 4 from radiation of infrared light generated by the heat dissipation source 10.

[0067] In some embodiments, the shielding component 6 may originate at a same or lower horizontal level than the sensor module 4, and may surround a side (e.g., an outside) of the sensor module 4. Further, the highest horizontal level of the shielding component may be greater than a highest horizontal level of the heat dissipation source 10.

[0068] In some embodiments, the system may further include a Fresnel lens 5, configured to cover the sensor module 4 and concentrate the incident infrared light for the sensor module 4. The highest horizontal level of the shielding component 6 is no greater than a highest horizontal level of the Fresnel lens 5.

[0069] The shielding component 6 may be configured in any proper ways. In one example, the shielding component 6 may be placed inside the Fresnel lens 5 and covered by the Fresnel lens 5 (e.g., as shown in FIG. 8). In another example, the shielding component 6 may be placed outside the Fresnel lens 5, and surrounds the Fresnel lens 5 (e.g., as shown in FIGS. 6, 7, and 9). The shielding component 6 may tightly wrap the Fresnel lens 5, or may be placed at a preset interval with the Fresnel lens 5. The sensitivity for measuring infrared variations of the outer environment of the sensor module 4 may not be effected by the shielding component 6. In yet another example, the shielding component 6 may include a first shielding member 6a and a second shielding member 6b (e.g., as shown in FIG. 10). The first shielding member 6a may be covered by the Fresnel lens 5, and the second shielding member 6b may surround an outside of the Fresnel lens 5.

[0070] It can be understood that, the disclosed system for preventing false triggering of a sensor module may be implemented on motion sensing appliances other than the sensor light, such as a motion sensing speaker, a motion sensing air conditioner, etc. The disclosed system may prevent false triggering of the sensor module caused by the heat dissipation source (e.g.,
5 a speaker, a power source, a radiator) in the same appliance.

[0071] Other embodiments of the disclosure will be apparent to those skilled in the art from consideration of the specification and practice of the invention disclosed herein. It is intended that the specification and examples be considered as exemplary only, with a true scope and spirit of the invention being indicated by the claims.

10

WHAT IS CLAIMED IS:

1. A sensor light, comprising:

a sensor module configured to measure incoming infrared light radiated to the sensor module, and generate a trigger signal when the measured infrared light meets a preset condition;

a light emitting module configured to emit light;

a power drive circuit connected to the sensor module and the light emitting module, and configured to receive the trigger signal from the sensor module, and control the light emitting module to emit light in response to the trigger signal received from the sensor module; and

a shielding component disposed between the sensor module and the light emitting module, and configured to shield the sensor module from radiation of infrared light generated by the light emitting module.

2. The sensor light according to claim 1, wherein:

the shielding component originates at a same or lower horizontal level than the sensor module, and surrounds a side of the sensor module; and

a highest horizontal level of the shielding component is greater than a highest horizontal level of the light emitting module;

wherein a horizontal level refers to a level of a plane perpendicular to an axis direction of the sensor light.

3. The sensor light according to claim 2, wherein:

the highest horizontal level of the shielding component is greater than a highest horizontal level of the sensor module.

4. The sensor light according to claim 2, further comprising:

a Fresnel lens configured to cover the sensor module and concentrate the incoming infrared light for the sensor module, wherein the light emitting module is located outside the Fresnel lens.

5. The sensor light according to claim 4, wherein:

the highest horizontal level of the shielding component is no greater than a highest horizontal level of the Fresnel lens.

6. The sensor light according to claim 4, wherein:

the shielding component is covered by the Fresnel lens.

7. The sensor light according to claim 4, wherein:

the shielding component surrounds an outside of the Fresnel lens.

8. The sensor light according to claim 4, wherein:

the shielding component includes a first layer and a second layer;

the first layer of the shielding component is covered by the Fresnel lens; and

the second layer of the shielding component surrounds a side of the Fresnel lens.

9. The sensor light according to any one of claims 1-8, wherein:

the shielding component has a single layer structure or includes multiple layers.

10. The sensor light according to any one of claims 1-8, wherein:

the shielding component includes a vertical wall or a slanted wall.

11. The sensor light according to any one of claims 1-8, wherein:

a top end of the shielding component is open; and a cross section of the shielding component has a circular shape, an eclipse shape, or a rectangular shape.

12. The sensor light according to any one of claims 4-8, wherein:

the sensor module is disposed on a center of a substrate of the light emitting module;

the light emitting module includes a plurality of Light Emitting Diode (LED) light emitters scattered around the center of the substrate of the light emitting module; and

a lens holder is disposed on a substrate of the sensor module for mounting the Fresnel lens.

13. The sensor light according to any one of claims 1-8, wherein:

a material of the shielding component is non-polyolefin.

14. The sensor light according to any one of claims 1-8, wherein:

a thickness of the shielding component and a distance between the shielding component and the light emitting module is determined based on a lighting intensity of the light emitting module.

15. The sensor light according to claim 3, wherein:

a height of the shielding component is determined based on a lighting intensity of the light emitting module, the highest horizontal level of the light emitting module, a location of the sensor module, and the highest horizontal level of the sensor module.

16. The sensor light according to claim 10, wherein:

a slanted degree of the shielding component corresponds to a lighting intensity of the light emitting module, a location of the sensor module, and the highest horizontal level of the sensor module.

17. The sensor light according to any one of claims 1-8, further comprising: a housing including an opening top part and a bottom part, a lamp holder for connecting to the bottom part of the housing, a reflector, and an optical lens structure; wherein:

the sensor module, the light emitting module, and the power drive circuit are installed in the housing through the opening top part;

the reflector and the optical lens structure are sequentially disposed at the opening top part; and

the optical lens structure has a compatible shape for covering the opening top part of the housing.

18. The sensor light according to claim 17, wherein:

an inner edge of the top opening part includes a first mounting structure and a second mounting structure, the first mounting structure being closer to a top end of the housing than the second mounting structure;

the optical lens structure is mounted on the first mounting structure by a first fastening piece; and

the light emitting module is mounted on the second mounting structure by a second fastening piece.

19. A system for preventing false triggering of a sensor module, comprising:

a sensor module configured to measure incoming infrared light radiated to the sensor module, and generate a trigger signal when the measured infrared light satisfies a preset condition; and

a shielding component located between the sensor module and a heat dissipation source, and configured to shield the sensor module from radiation of infrared light generated by the heat dissipation source.

20. The system according to claim 19, wherein:

the shielding component originates at a same or lower horizontal level than the sensor module, and surrounds a side of the sensor module; and

the highest horizontal level of the shielding component is greater than a highest horizontal level of the heat dissipation source.

21. The system according to claim 20, further comprising:

a Fresnel lens configured to cover the sensor module and concentrate the incoming infrared light for the sensor module, wherein the highest horizontal level of the shielding component is no greater than a highest horizontal level of the Fresnel lens.

22. The system according to claim 21, wherein:

the shielding component includes at least one of: a first layer covered by the Fresnel lens, or a second layer surrounding a side of the Fresnel lens.

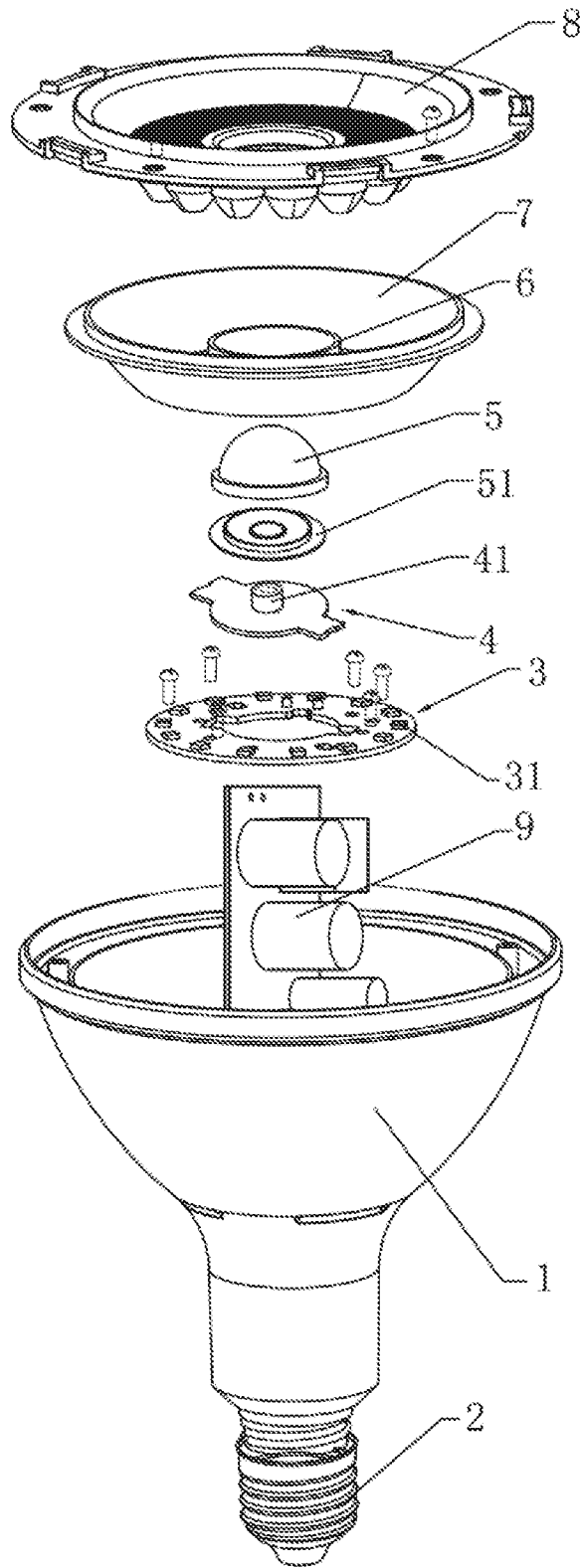

FIG. 1

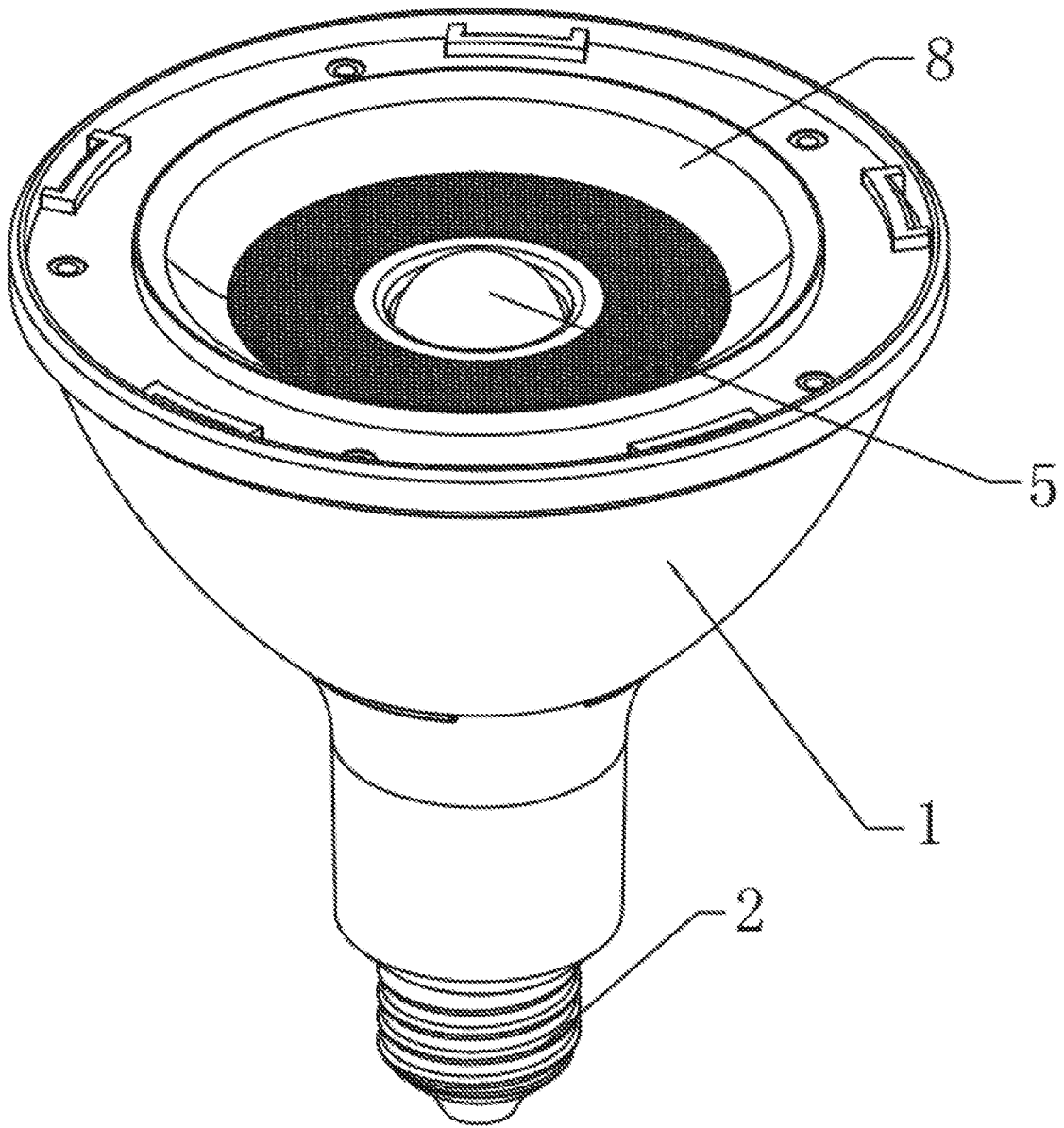

FIG. 2

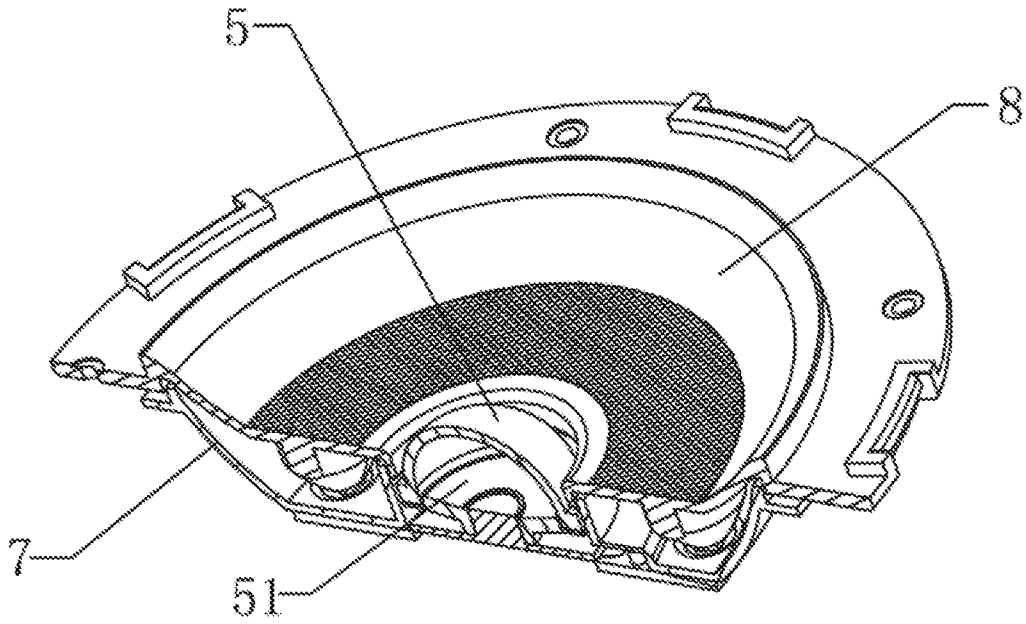

FIG. 3

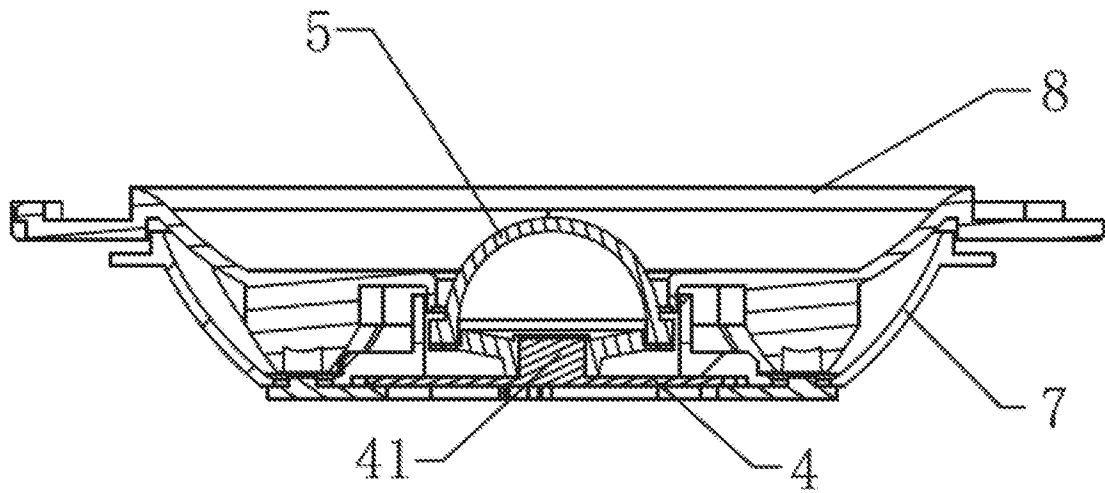

FIG. 4

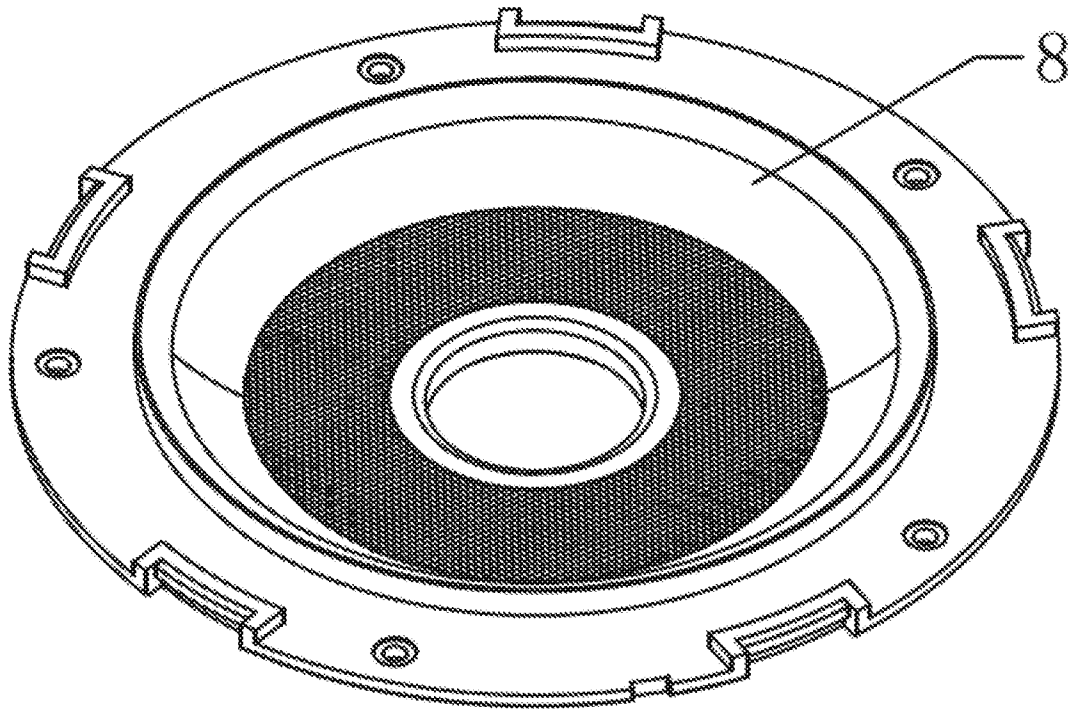

FIG. 5

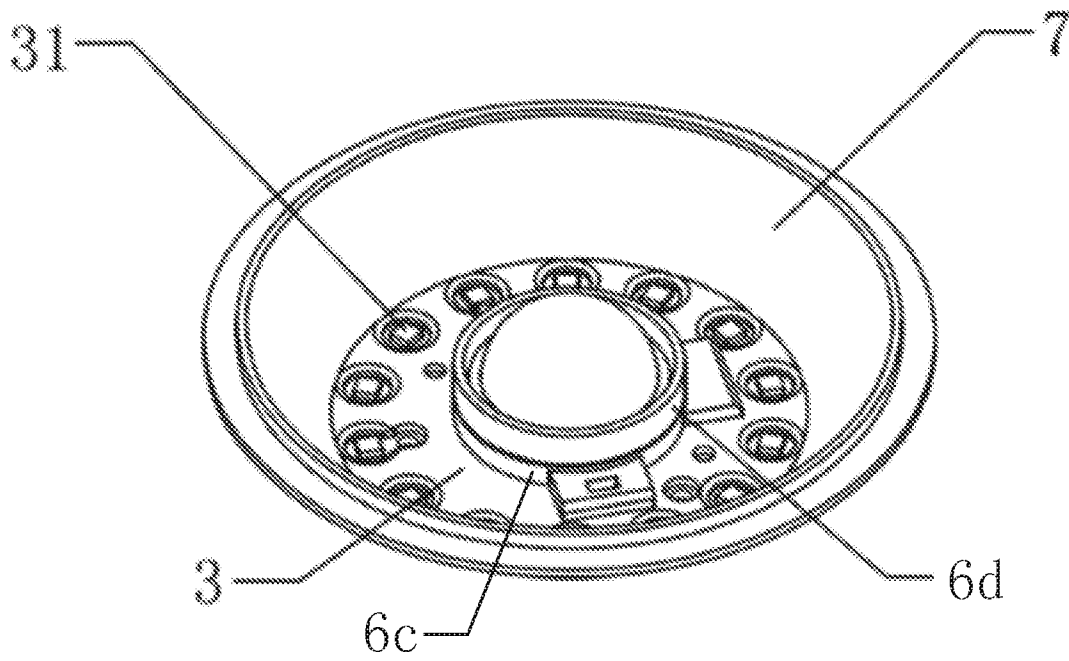

FIG. 6

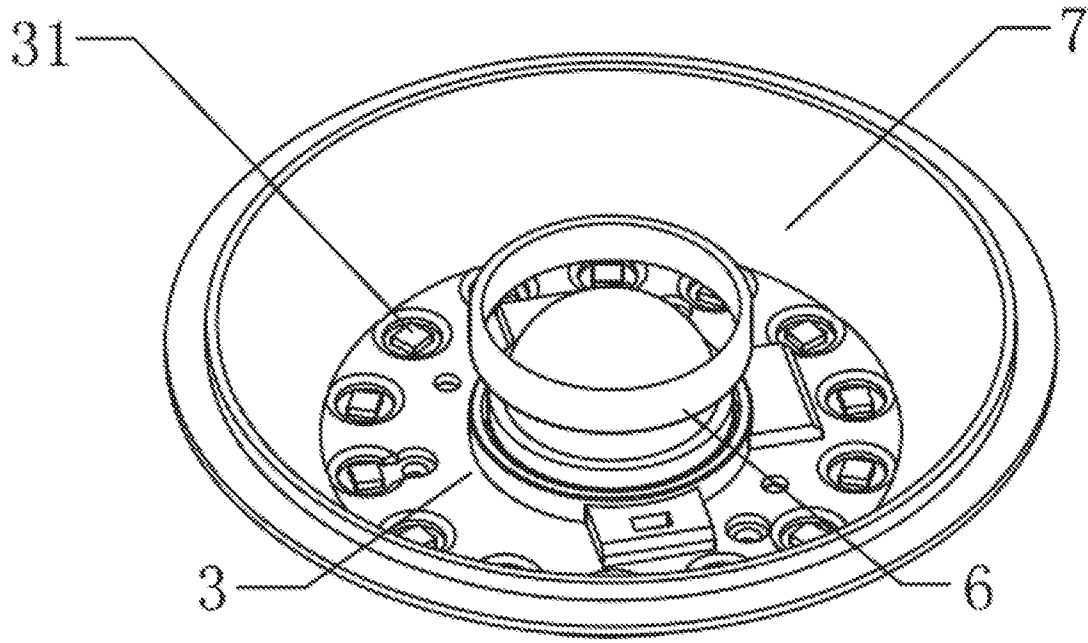

FIG. 7

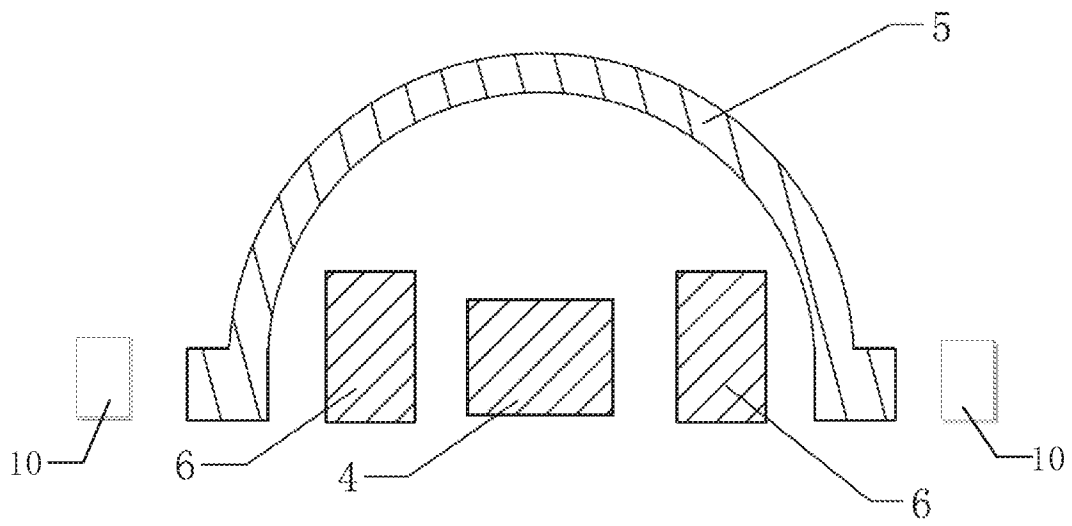

FIG. 8

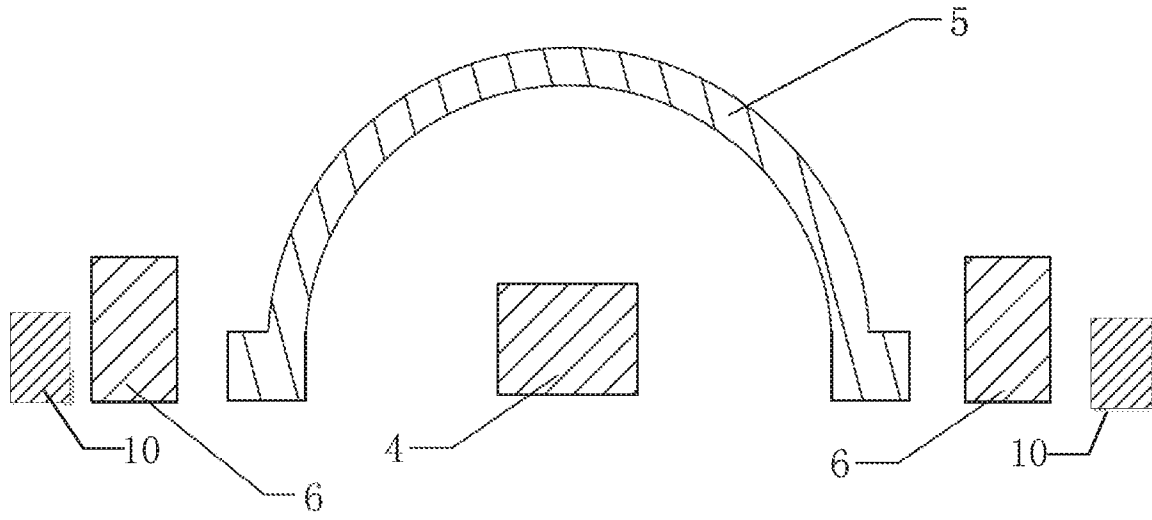

FIG. 9

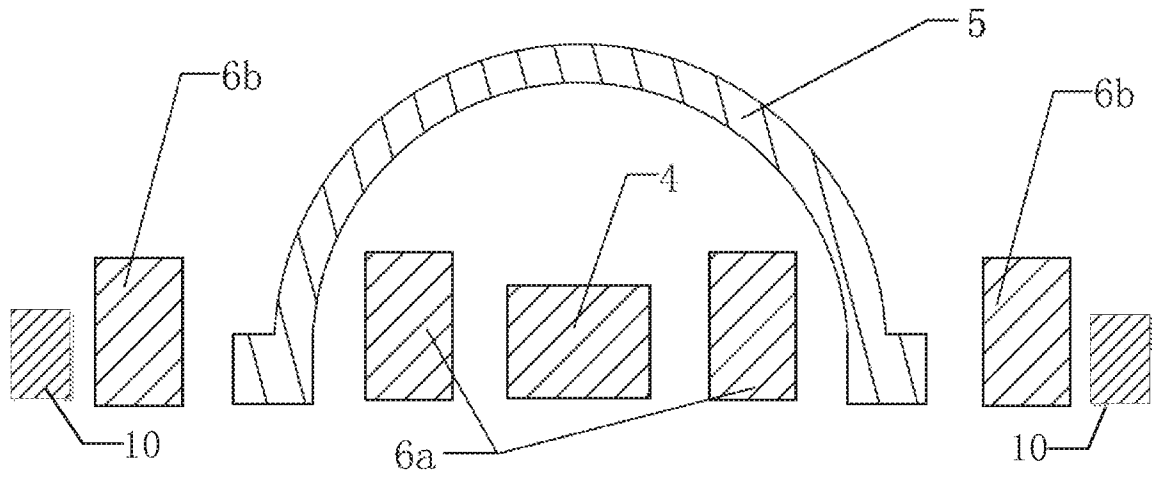

FIG. 10

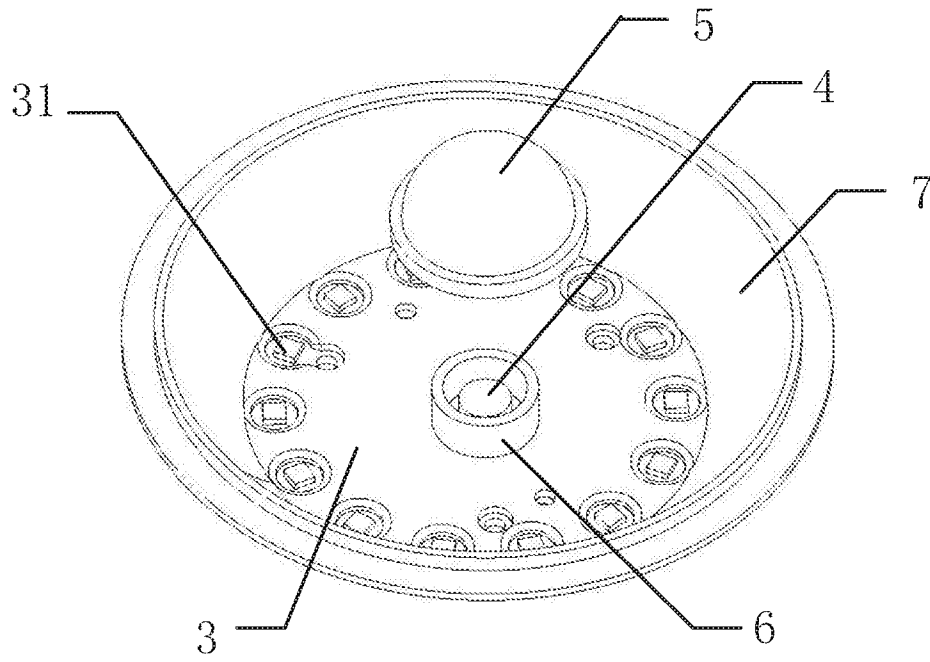

FIG. 11

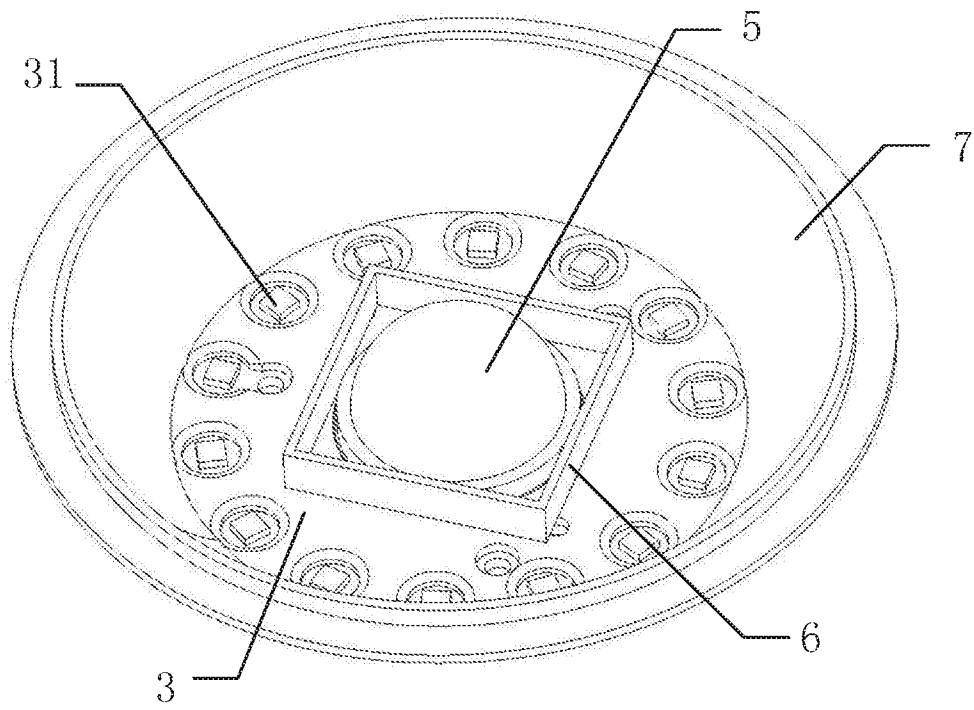

FIG. 12

INTERNATIONAL SEARCH REPORT

International application No.

PCT/CN2017/091938

A. CLASSIFICATION OF SUBJECT MATTER

F21K 9/20(2016.01)i; F21V 5/04(2006.01)i; F21V 17/12(2006.01)i; F21V 23/04(2006.01)i; F21Y 115/10(2016.01)i

According to International Patent Classification (IPC) or to both national classification and IPC

B. FIELDS SEARCHED

Minimum documentation searched (classification system followed by classification symbols)

F21K; F21V; F21Y

Documentation searched other than minimum documentation to the extent that such documents are included in the fields searched

Electronic data base consulted during the international search (name of data base and, where practicable, search terms used)

CNPAT,CNKI,WPI,EPODOC: sensor, detect???, human, body, infrared, prevent???, LED, light w emitting w diode?, light???, shield???, radiation

C. DOCUMENTS CONSIDERED TO BE RELEVANT

Category*	Citation of document, with indication, where appropriate, of the relevant passages	Relevant to claim No.
PX	CN 106594538 A (ZHEJIANG SHENGHUI LIGHTING CO., LTD.) 26 April 2017 (2017-04-26) description, paragraphs [0041]-[0074] and figures 1-10	1-22
X	CN 202144953 U (DONGGUAN LIVINGSTYLE ENTERPRISES LTD.) 15 February 2012 (2012-02-15) description, paragraphs [0002], [0020]-[0032] and figures 1-4	1-22
X	CN 202140838 U (DONGGUAN LIVINGSTYLE ENTERPRISES LTD.) 08 February 2012 (2012-02-08) description, paragraphs [0002], [0018]-[0028] and figures 1-3	1-22
A	CN 201396633 Y (XU, GUANGMING) 03 February 2010 (2010-02-03) the whole document	1-22
A	CN 2366688 Y (LAMP DECORATION ELECTRIC APPLI.) 01 March 2000 (2000-03-01) the whole document	1-22
A	JP 2007265836 A (YUKITA SUNTEC K.K.) 11 October 2007 (2007-10-11) the whole document	1-22

 Further documents are listed in the continuation of Box C. See patent family annex.

* Special categories of cited documents:

"A" document defining the general state of the art which is not considered to be of particular relevance

"E" earlier application or patent but published on or after the international filing date

"L" document which may throw doubts on priority claim(s) or which is cited to establish the publication date of another citation or other special reason (as specified)

"O" document referring to an oral disclosure, use, exhibition or other means

"P" document published prior to the international filing date but later than the priority date claimed

"T" later document published after the international filing date or priority date and not in conflict with the application but cited to understand the principle or theory underlying the invention

"X" document of particular relevance; the claimed invention cannot be considered novel or cannot be considered to involve an inventive step when the document is taken alone

"Y" document of particular relevance; the claimed invention cannot be considered to involve an inventive step when the document is combined with one or more other such documents, such combination being obvious to a person skilled in the art

"&" document member of the same patent family

Date of the actual completion of the international search

06 September 2017

Date of mailing of the international search report

11 October 2017

Name and mailing address of the ISA/CN

STATE INTELLECTUAL PROPERTY OFFICE OF THE
P.R.CHINA
6, Xitucheng Rd., Jimen Bridge, Haidian District, Beijing
100088
China

Authorized officer

QUAN, Yujun

Facsimile No. (86-10)62019451

Telephone No. (86-10)61648437

INTERNATIONAL SEARCH REPORT
Information on patent family members

International application No.

PCT/CN2017/091938

Patent document cited in search report			Publication date (day/month/year)	Patent family member(s)			Publication date (day/month/year)
CN	106594538	A	26 April 2017	None			
CN	202144953	U	15 February 2012	WO	2012171286	A1	20 December 2012
				JP	2014517483	A	17 July 2014
				JP	5844893	B2	20 January 2016
				EP	2722586	A1	23 April 2014
				US	2014092603	A1	03 April 2014
				WO	2012171467	A1	20 December 2012
				EP	2722576	A1	23 April 2014
				US	2014126221	A1	08 May 2014
				US	9360170	B2	07 June 2016
				JP	2014517486	A	17 July 2014
CN	202140838	U	08 February 2012	WO	2012171287	A1	20 December 2012
				US	2014140067	A1	22 May 2014
				JP	2014517484	A	17 July 2014
				JP	6029661	B2	24 November 2016
				EP	2722585	A1	23 April 2014
				WO	2012171467	A1	20 December 2012
				EP	2722576	A1	23 April 2014
				US	2014126221	A1	08 May 2014
				US	9360170	B2	07 June 2016
				JP	2014517486	A	17 July 2014
CN	201396633	Y	03 February 2010	None			
CN	2366688	Y	01 March 2000	None			
JP	2007265836	A	11 October 2007	None			