

P. WINEMAN.
MACHINE FOR SAWING STAVES.

APPLICATION FILED FEB. 24, 1902.

NO MODEL.

4 SHEETS—SHEET 1.

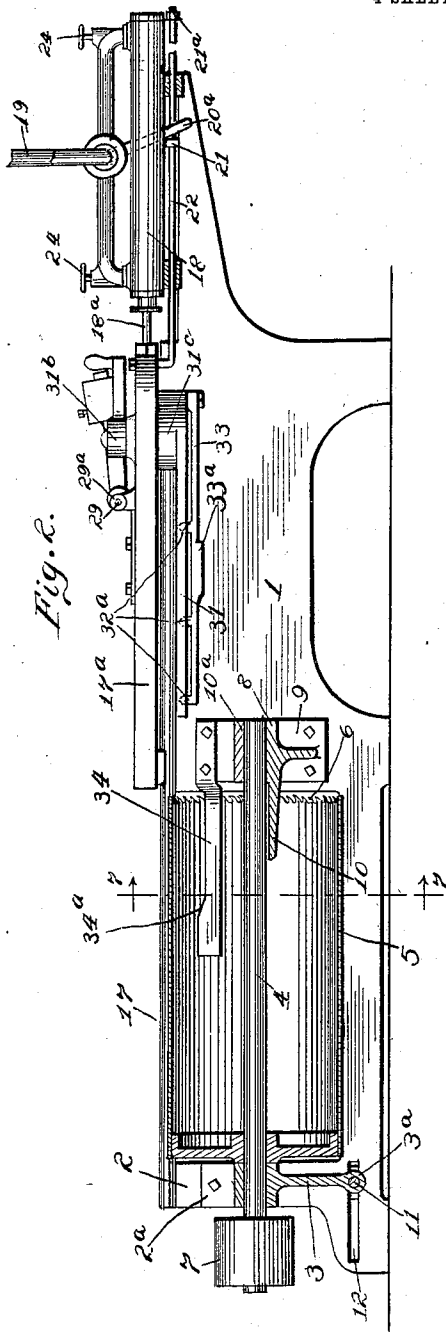
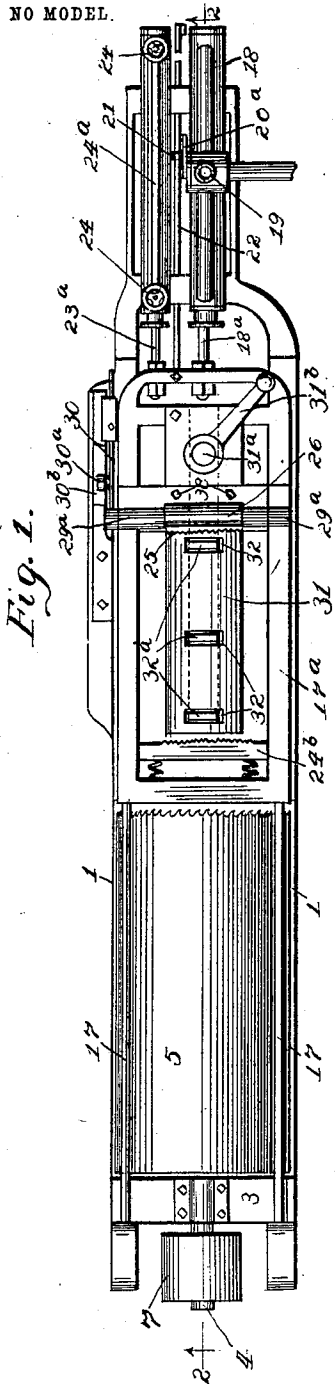

Witnesses:
 C. S. Sawyer.
 C. F. Rembold.

Inventor:
 Parker Wineman
 By J. H. King, Atty.

No. 725,908.

PATENTED APR. 21, 1903.

P. WINEMAN.
MACHINE FOR SAWING STAVES.

APPLICATION FILED FEB. 24, 1902.

NO MODEL.

4 SHEETS—SHEET 2.

Fig. 3.

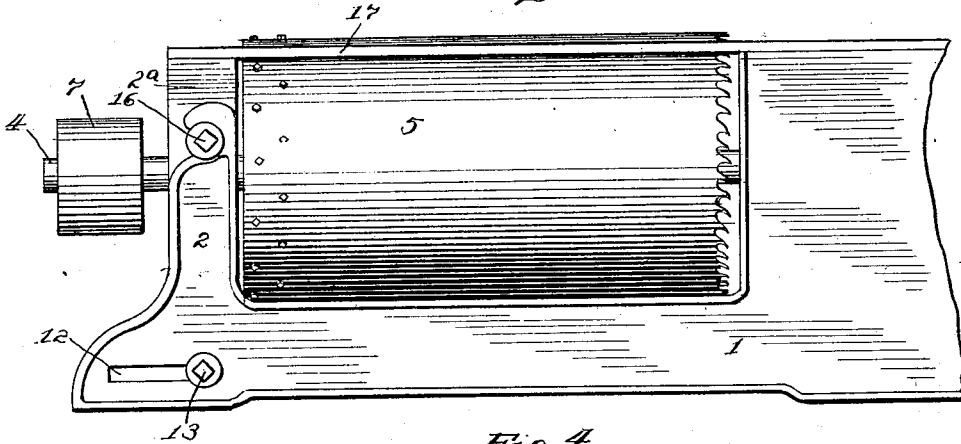

Fig. 4.

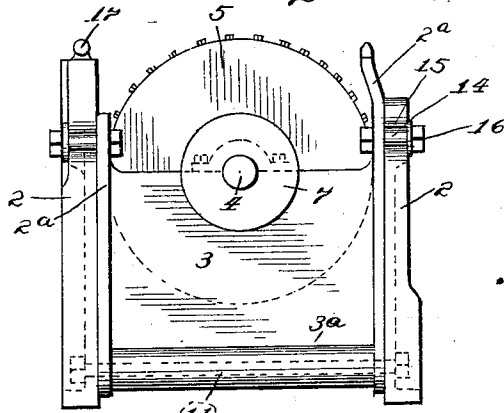
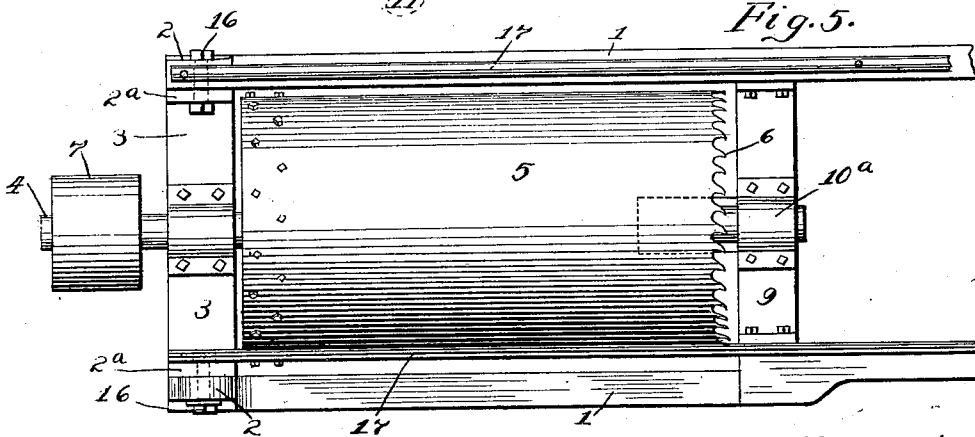

Fig. 5.



Witnesses:

C. S. Sanger.

C. F. Reinboth.

Inventor:

Paul W. Wineman

By J. F. King, Att'y.

P. WINEMAN.
MACHINE FOR SAWING STAVES.
APPLICATION FILED FEB. 24, 1902.

NO MODEL.

4 SHEETS—SHEET 3.

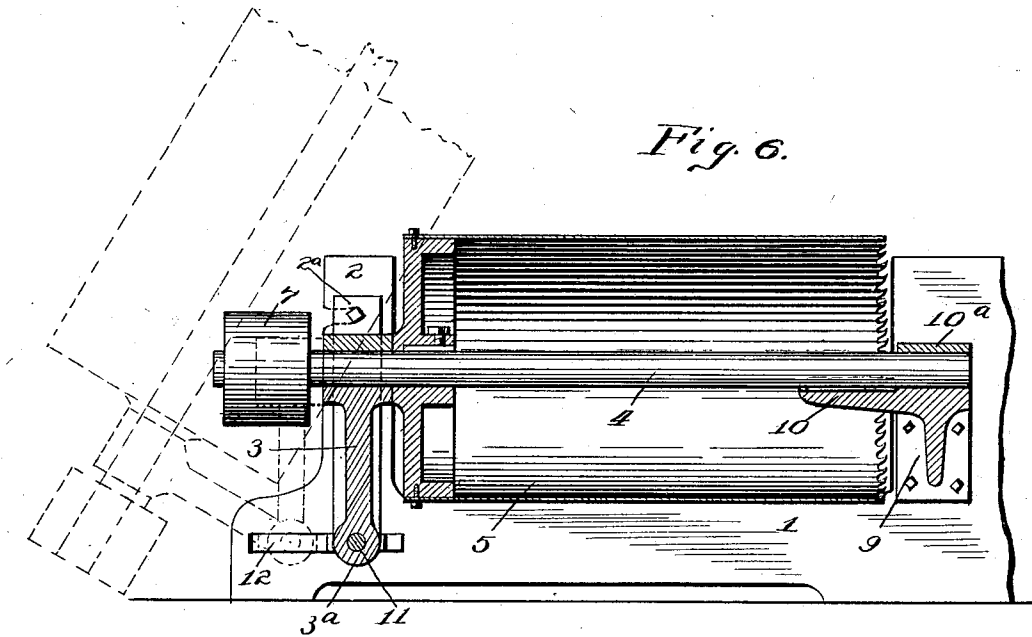

Fig. 6.

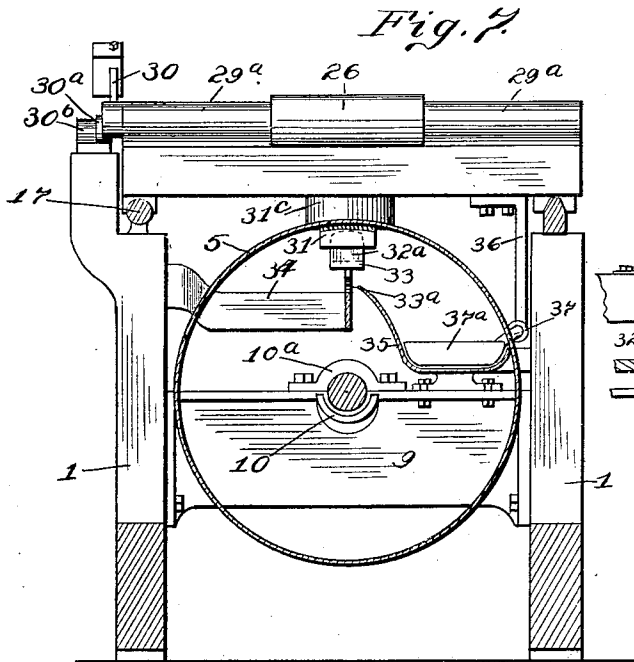

Fig. 7.

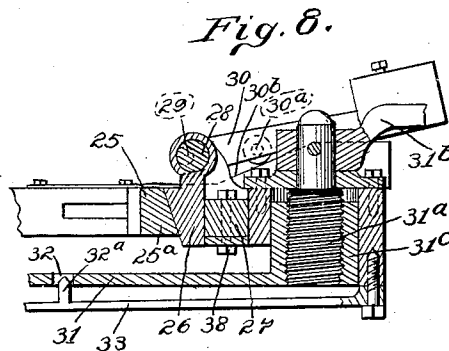

Fig. 8.

Witnesses:
C. S. Sanger.
C. F. Remboldt

Inventor:
Carver Wineman
By J. H. King, atty.

P. WINEMAN.
MACHINE FOR SAWING STAVES.

APPLICATION FILED FEB. 24, 1902.

NO MODEL.

4 SHEETS—SHEET 4.

Fig. 9.

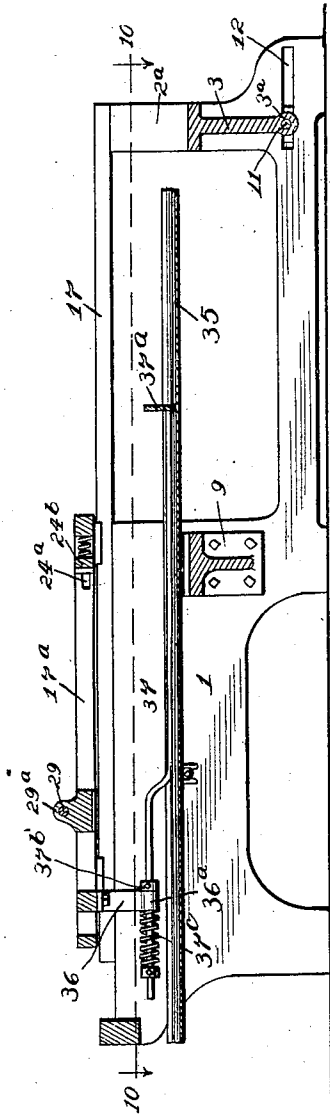

Fig. 10.

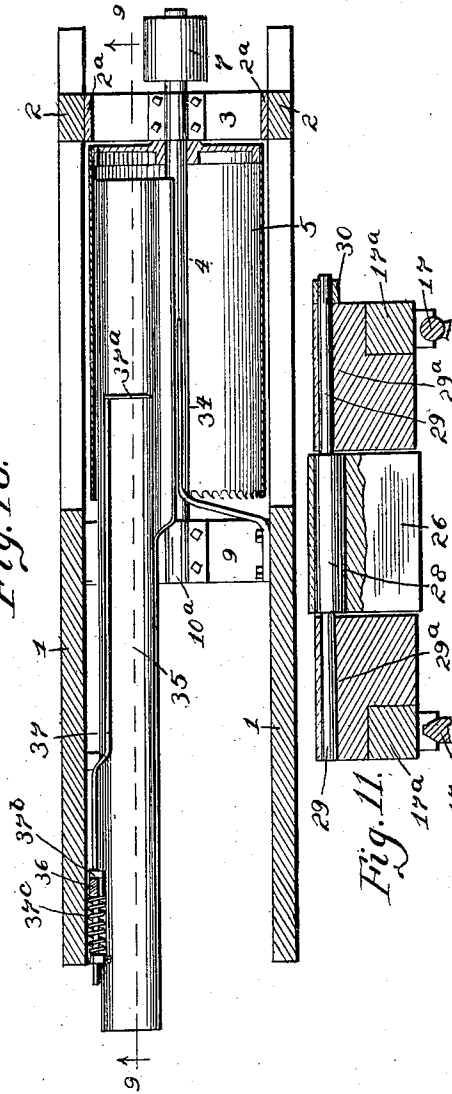
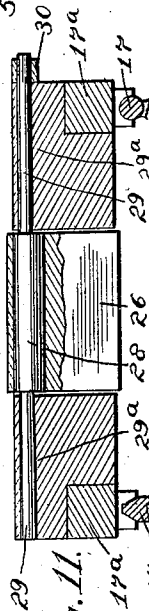

Fig. 11.



Witnesses:
 C. S. Sanger
 C. F. Remloth

Inventor:
 Parker Wineman
 By J. H. King-Att'y

UNITED STATES PATENT OFFICE.

PARKER WINEMAN, OF AUSTIN, ILLINOIS.

MACHINE FOR SAWING STAVES.

SPECIFICATION forming part of Letters Patent No. 725,908, dated April 21, 1903.

Application filed February 24, 1902. Serial No. 95,255. (No model.)

To all whom it may concern:

Be it known that I, PARKER WINEMAN, a citizen of the United States, residing at Austin, in the county of Cook and State of Illinois, have invented certain new and useful Improvements in Machines for Sawing Staves, of which the following, taken in connection with the accompanying drawings, is a description.

My invention relates to apparatus whereby staves are cut by a cylindrical saw from a stave-bolt and after each operation the bolt gravitates down upon a rest.

The primary object of my invention is to simplify and improve the construction of such machines and render them more reliable and an increased production at less cost.

Another object of my invention is to provide means for operating the carriage by a steam or air cylinder which shall be simple in construction and effective in operation; and a further object is to provide means for regulating the speed of the piston in the steam or air cylinder by the use of oil resistance in a cylinder connected to the carriage which will be effective and reliable.

Another object of my invention is to provide mechanism for regulating the thickness of the stave which is quickly and easily operated, as well as to provide means for delivering the stave at the end of the machine convenient for removal.

A further object of my invention is to provide means whereby the cylinder or drum may be turned from a normal horizontal position to any angle or to a vertical position for convenience in filing the teeth or swaging without the necessity of unbolting or removing the caps from the boxes, as has heretofore been the case when it was necessary to change the position of the cylinder for the purpose mentioned. This object I accomplish by mechanism which is exceedingly simple in construction and operation.

Other novel features of my machine will be hereinafter more particularly pointed out in the claims.

In carrying out my invention I provide mechanism which I have illustrated in preferred form in the accompanying drawings, in which—

Figure 1 is a top plan view of a machine em-

bodifying my invention. Fig. 2 is a side elevation thereof, partly in section. Fig. 3 is an enlarged view, in side elevation, of the rear end of the machine, illustrating the manner of mounting the drum or cylinder saw. Fig. 4 is a rear end elevation of the parts shown in the preceding figure and on the same scale. Fig. 5 is a top plan view of said parts on said scale. Fig. 6 is a longitudinal vertical section, enlarged, through so much of the machine as is shown in Fig. 3, illustrating diagrammatically the position taken when the saw is being turned up for filing. Fig. 7 is a rear elevation of the machine in transverse section through the saw; Fig. 8, an enlarged detail of the apparatus for releasing the stave-bolt and for determining the thickness of the staves. Fig. 9 is a side elevation with the drum-saw removed, showing the trough mechanism. Fig. 10 is a top plan view of the same, and Fig. 11 is a detail.

Referring to the drawings, 1 indicates a strong supporting-frame having standards 2, between which is mounted an end frame 2^a, having a shaft-bearing 3, which supports the rear end of the shaft 4, which revolves the drum-saw 5. This drum-saw 5 is provided with the usual saw-teeth 6 at its forward edge and constitutes what will be hereinafter termed a "cylindrical saw." This saw is revolved upon the shaft 4 by means of a belted pulley 7, located at the rear end of the shaft 4.

The forward end of the saw-shaft is journaled in a bearing 8 upon a bridge 9, connecting the two sides of the frame. A projection of this bearing 8 is prolonged rearwardly at 10 beyond the cap 10^a, so that the shaft may be drawn out clear of the cap and still be supported upon said projection 10. The supporting-frame 1 is connected at its lower rear end by a bolt 11, passing through a hinge-bearing 3^a, which is adapted, when the nut is released, to slide in longitudinal slots 12 and is clamped therein by the nut 13. The upper part of the frame 2^a of the hinge-bearing is secured to the standards 2 by means of bolts 14, which enter slots 15, opening to the rear in said standards 2, and are clamped therein by means of nuts 16. Now if nuts 13 and 16 are loosened the saw and its shaft may be drawn to the rear in the longitudinal slots 12 until the shaft is clear of the cap 10^a of its forward

bearing and resting only upon the extension or projection 10, when the hinge-bearing is thrown back on the pivot-bolt 11, bringing the parts in the position represented in dotted lines, Fig. 6, with the saw-teeth elevated in convenient position for filing or setting. To restore the parts to effective position, it is only necessary to rock the hinge-bearing frame forward until the front end of the shaft strikes the projection 10, then push it forward to the limit of the slots 12 and 15, and then tighten up the bolts 11 and 14.

Upon longitudinal guideways 17 on each side of the saw is mounted a reciprocating carriage 17^a. This is actuated by steam or air pressure introduced into one or the other end of the cylinder 18 by steam or air pipe 19, having a regulating-valve at the junction of its branches. The handle 20^a of this valve depends between two pins or tappets 21 21^a on a bar 22, attached to the carriage, so as to be struck alternately by either pin and direct the motive pressure to one end or the other of the cylinder when the carriage has once been set in motion, which will be done (as will the stopping thereof) by hand manipulation of the valve. The lugs or tappets 21 21^a are adjustable on the bar 22, so that the length of piston-stroke may be regulated according to the length of stave to be cut. The piston-rod 18^a of the cylinder is connected to the adjacent end of the bar of the carriage, and this connection is preferably adjustable for repairs, &c., as shown.

A second cylinder shown alongside the first is an oil-cylinder, the piston-rod 23^a of which is operated by connection with the reciprocating carriage and has a regulating valve or valves 24 24 for said cylinder. The purpose of this oil-cylinder is to regulate the speed of the motor-piston in feeding the stave-bolt to and from the stave, according to the nature of the wood from which the stave is to be cut. To this end it has a return-pipe 24^a, through which the flow of oil is more or less obstructed by opening or closing the regulating-valves 24 24. When the steam has been cut off from the forward movement of the motive cylinder, the valve is opened to its full extent, that the carriage may be returned rapidly, thereby greatly increasing the capacity of the machine.

In the longitudinal slots or guide-grooves in the rear end of the side bars of the reciprocating carriage is mounted the rear dog 24^b, while in similar slots toward the front end of said carriage is mounted the front dog 25. The back bar 25^a of the front dog is beveled, as shown in Fig. 8, and with it engages a broad wedge 26, supported against a laterally-adjustable transverse bar 27. The upper end of the wedge 26 is formed as a sleeve or strap to take over a long eccentric 28, secured to transverse shaft 29, mounted in bearings 29^a upon the carriage, so that when the shaft is revolved the eccentric is turned down, pressing the front dog against the

stave-bolt and securely holding it until the stave is cut and carriage returned. When it is lifted up, the front dog is released from engagement with the stave-bolt. The rocking of the shaft 29 is effected by means of a weighted lever 30, secured thereto and carrying an adjustable pin 30^a, which toward the completion of the retractive movement of the carriage rides up an incline 30^b and lifts said lever 30 and the wedge 26 in a direction calculated to release the front dog, and in the incipency of the reverse movement the pin 30^a rides down said incline, when the weight on the lever forces the wedge 26 down and reengages said dog.

Extending lengthwise beneath the reciprocating carriage, centrally thereof and supported therefrom, is the stave-bolt support 31, adjustable up and down to determine the thickness of the staves by means of screw 31^a, with handle 31^b located at the front end of the carriage, and taking into a threaded boss 31^c, upstanding from the support a sufficient distance to render the connection rigid. This support 31 at its rear end is unattached to the carriage, being intended to pass inside the drum-saw and support the stave while being separated from the bolt. It has a plurality of transverse apertures 32, with which register ribs 32^a upon an underlying spring-bar 33, secured at its front end to said support, and therefore adjustable therewith. Beneath this spring-bar and about centrally of the length thereof is secured a projection, such as a wedge 33^a, and an adjustable bar 34, held by bolts to the framework, extends within the cylindrical saw and has at its rear end an incline 34^a, and the operation of the sliding carriage is such that after the stave has been severed it continues its advancing movement an inch or so farther, carrying the projection or wedge 33^a up the incline 34^a, thereby protruding the ribs 32^a through the apertures 32, lifting the stave off from the support 31, and pressing it against the interior surface of the drum, when the friction of the latter as it rotates will carry the stave laterally off from the ribs and support and let it drop into the trough.

The falling stave is received in a trough 35, extending from the bridge 9 to the rear end of the drum, and in the retracting movement of the carriage is swept therefrom and discharged in the following manner: Secured to the frame of the reciprocating carriage on that side corresponding to the location of the trough is a hanger 36, having a horizontal sleeve 36^a at its lower end, in which is mounted a rod 37 of such length beyond the hanger that in the advancing movement of the carriage it will be thrust along the inner side of the drum and trough clear to the rear end of the latter. This rod carries at its extreme end a laterally-extending plate or clearer 37^a, conforming to the outline of the trough, and it will be understood that when the stave is severed and dropped into the trough, as above

explained, it will lie therein immediately in front of the clearer. Consequently when the carriage is in its retracting movement the stave will be swept out of the trough and deposited on the floor at the end of the machine, where it may be removed by an attendant. The rod 37 may be secured rigidly to the hanger-sleeve or may be cushioned thereagainst by stop 37^b and spring 37^c, as shown. The trough is detachably secured to the bridge 9 and on the inside of the supporting-frame 1, so that it may be readily removed when it is desired to tilt the drum-saw.

The support for the wedge is adjusted along the same side grooves 25^a in which the front dog slides by means of adjusting bolts or screws 38, set in the front transverse bar or support, and supports the bearings for the eccentric-shaft which operates the adjusting-wedge 26. The purpose of such adjustment of the support is to allow for the cutting of longer or shorter staves, and it will obviously be attended by corresponding adjustments of the lugs or tappets 21 21^a to regulate length of piston-stroke. The incline 30^b, upon which the pin 30^a in the weighted lever rides, is also adjusted to correspond to the adjustments of the supports and lugs in the cutting of longer or shorter staves.

Having thus described my invention, what I claim as new, and desire to secure by Letters Patent, is—

1. In a machine of the class described, the combination with the reciprocating carriage and the power-cylinder for driving it, of the rear dog, the front dog having a beveled back, the vertically-movable wedge acting against the bevel, the eccentric by which said wedge is moved, the shaft carrying said eccentric, the weighted lever attached to said shaft, the pin thereon and the incline up which said pin rides to cause the lifting of the wedge, substantially as described.

2. In a machine of the class described, the combination with the carriage and its dogs and with the drum-saw, of the transversely-slotted stave-bolt support extending longitudinally beneath said carriage, the spring-bar therebeneath having transverse ribs registering with the slots through said support, the wedge or projection 33^a secured beneath the spring-bar, and the incline within the drum up which said projection rides to lift the severed stave off of its support and press it against the drum, substantially as described.

3. In a machine of the class described, the combination with the reciprocating carriage, the power-cylinder, the drum-saw, and with means for raising the severed stave off of its support and pressing it frictionally against the drum, of a fixed trough extending within the drum to receive said stave as it is swept laterally away from said support by the revolution of the drum, and an ejector secured to the reciprocating carriage, and sweeping said trough in the retractive movement of the carriage, substantially as described.

4. In a machine of the class described, the combination with the drum-saw, the cooperating front and rear dogs, the vertically-movable wedge mounted in a reciprocating carriage, the eccentric, the shaft carrying said eccentric, and the lever attached to said shaft, substantially as described.

5. In a machine of the class described, the combination with the drum-saw, the reciprocating carriage, the front and rear dogs, said front dog having a beveled back, the vertically-movable wedge acting against the bevel, the eccentric by which said wedge is moved, the shaft carrying said eccentric, the weighted lever attached to said shaft, the pin thereon, and an incline up which said pin rides to cause the lifting of the wedge, substantially as described.

6. In a machine of the class described, the combination with a supporting-frame, a drum-saw having a receiving-trough located therein, a reciprocating carriage having a transversely-slotted stave-bolt support secured thereto, a ribbed bar secured to said support, an inclined bar secured to the supporting-frame over which the ribbed bar passes whereby the ribs are forced through the transverse slots in the stave-bolt support and the stave is pressed against the drum-saw, the centrifugal force of which conveys the stave to the trough, and means for discharging the stave from the trough, substantially as described.

7. In a machine of the class described, the combination with a supporting-frame, a drum-saw having a receiving-trough located therein, an inclined adjustable bar secured to the supporting-frame and extending within said drum-saw, of a reciprocating carriage having an adjustable stave-bolt support secured thereto, said support adapted to travel up the aforesaid inclined bar as the carriage passes over the saw, and press the stave frictionally against said saw, the centrifugal force of which carries the stave into the trough, and an ejector secured to said carriage whereby the stave-bolt is removed from the trough substantially as described.

8. In a machine of the class described, the combination of the drum-saw, a trough located therein, the reciprocating carriage having a hanger which travels back and forth within said trough as the carriage reciprocates, said reciprocating carriage having a transversely-slotted stave-bolt secured thereto, a spring-bar secured to said support having ribs which register with the slots therein to force the stave against the revolving saw, substantially as described.

9. In a machine of the character described, the combination with the carriage, means for clamping and releasing the dogs, of the transversely-slotted vertically-adjustable stave-bolt support therebeneath, a spring-bar having ribs, said bar secured to and traveling with the stave-bolt support, and an incline upon which said spring-bar travels, said ribs being thereby forced through the transverse

slots to elevate the stave, substantially as described.

10. In a machine of the character described, the combination with the drum-saw, the carriage and the transversely-slotted stave-bolt support extending longitudinally beneath said carriage, the spring-bar therebeneath having transverse ribs registering with the slots through said support, the incline or projection 33^a secured beneath the spring-bar, and the corresponding incline within the drum upon which said projection rides to lift the severed stave off from its support and press it against the drum, substantially as described.

11. In a machine of the class described, the combination with a drum-saw and reciprocating carriage, a transversely-slotted stave-bolt support and means for raising the severed stave off from its support and pressing it frictionally against the drum, substantially as described.

12. In a machine of the class described the combination with the reciprocating carriage and drum-saw, a transversely-slotted stave-bolt support, means for raising the severed stave off from its support, and pressing it frictionally against the drum, of a trough extending within the drum to receive said stave as it is swept laterally away from said support by the revolution of the drum and an ejector secured to the sliding carriage and sweeping said trough in the retractive movement of the carriage, substantially as described.

13. In a machine of the class described, the combination with the supporting-frame, having slots in the rear end thereof, the drum-saw and its shaft, a bearing for the forward end of said shaft from which it may be removed when drawn rearwardly, of a tilting support or hinged bearing therefor movable in said slots whereby the saw-teeth of said drum may be raised to a convenient position for filing or setting.

14. In a machine of the class described, the combination with the drum-saw and its shaft, the supporting-frame having outwardly-opening slots 15 and longitudinal slots 12 in the rear end thereof through which passes a bolt 11 which forms a hinge-bearing and the projection 10 in which the shaft rests when the saw is drawn out preparatory to tilting, substantially as described.

15. In a machine for sawing staves the combination of a drum-saw mounted upon a revoluble shaft, a supporting-frame, having outwardly-opening longitudinal slots in the upper rear end thereof in which the shaft-bearing

frame engages, and longitudinal slots 12 for receiving the bolt 11 which forms a hinge upon which the drum-saw may be swung to vertical position and a bearing for the forward end of said saw-shaft from which it may be withdrawn by the rearward movement of the rear bearing, substantially as described.

16. In a machine for sawing staves, the combination of a revoluble drum-saw, a supporting-frame having longitudinal slots 12 through which passes a bolt 11 which forms a hinge whereby the drum-saw may be tilted to vertical position, and a bearing for the forward end of the drum-saw shaft from which bearing the shaft may be withdrawn when tilted vertically, substantially as described.

17. In a machine for sawing staves, the combination with a drum-saw and its longitudinally-movable shaft, of the front bearing for said shaft having a projection extending rearwardly beyond the cap, and the longitudinal slots and bolt forming a hinged bearing in connection with the rear shaft-bearing upon which the rear end of the drum-saw shaft is mounted, substantially as described.

18. In a machine for sawing staves, the combination with the drum-saw, the motor-cylinder, the reciprocating carriage, the front and rear dogs, one of the dogs having a beveled back, the vertically-movable wedge acting against the bevel, the eccentric mounted upon a transverse shaft, said shaft having a weighted lever, said weighted lever traveling up an incline thereby lifting the wedge, substantially as described.

19. In a machine for sawing staves, the combination with the drum-saw, the motor-cylinder, the reciprocating carriage and the transversely-slotted stave-bolt support extending longitudinally beneath said carriage, a spring-bar having ribs registering with the slots in said support, the incline beneath the spring-bar, and the corresponding incline within the drum, substantially as described.

20. In a machine for sawing staves, the combination with a drum-saw, a reciprocating carriage a motor-cylinder for moving said carriage, a transversely-slotted stave-bolt support secured to the reciprocating carriage, a bar having ribs secured to said support and traveling with it, means for forcing said ribs through the transverse slots in the stave-bolt support to press the stave against the drum-saw, substantially as described.

PARKER WINEMAN.

Witnesses:

C. S. SANGER,
C. F. REINBOTH.