

(19) World Intellectual Property Organization
International Bureau



(43) International Publication Date
12 September 2008 (12.09.2008)

PCT

(10) International Publication Number
WO 2008/109563 A2

- (51) International Patent Classification:
G02B 23/10 (2006.01)
- (21) International Application Number:
PCT/US2008/055717
- (22) International Filing Date: 3 March 2008 (03.03.2008)
- (25) Filing Language: English
- (26) Publication Language: English
- (30) Priority Data:
60/892,815 2 March 2007 (02.03.2007) US
- (71) Applicant and
(72) Inventor: KOENIG, Dean, B. [US/US]; 1049 W. Eagle
Look Lane, Oro Valley, Arizona 85737 (US).
- (74) Agents: SOLOWAY, Norman, P. et al.; c/o HAYES
SOLOWAY P.C., 3450 E. Sunrise Drive, Suite 140,
Tucson, Arizona 85718 (US).
- (81) Designated States (unless otherwise indicated, for every
kind of national protection available): AE, AG, AL, AM,

AO, AT, AU, AZ, BA, BB, BG, BH, BR, BW, BY, BZ, CA, CH, CN, CO, CR, CU, CZ, DE, DK, DM, DO, DZ, EC, EE, EG, ES, FI, GB, GD, GE, GH, GM, GT, HN, HR, HU, ID, IL, IN, IS, JP, KE, KG, KM, KN, KP, KR, KZ, LA, LC, LK, LR, LS, LT, LU, LY, MA, MD, ME, MG, MK, MN, MW, MX, MY, MZ, NA, NG, NI, NO, NZ, OM, PG, PH, PL, PT, RO, RS, RU, SC, SD, SE, SG, SK, SL, SM, SV, SY, TJ, TM, TN, TR, TT, TZ, UA, UG, US, UZ, VC, VN, ZA, ZM, ZW.

(84) Designated States (unless otherwise indicated, for every kind of regional protection available): ARIPO (BW, GH, GM, KE, LS, MW, MZ, NA, SD, SL, SZ, TZ, UG, ZM, ZW), Eurasian (AM, AZ, BY, KG, KZ, MD, RU, TJ, TM), European (AT, BE, BG, CH, CY, CZ, DE, DK, EE, ES, FI, FR, GB, GR, HR, HU, IE, IS, IT, LT, LU, LV, MC, MT, NL, NO, PL, PT, RO, SE, SI, SK, TR), OAPI (BF, BJ, CF, CG, CI, CM, GA, GN, GQ, GW, ML, MR, NE, SN, TD, TG).

Published:
— without international search report and to be republished upon receipt of that report
— with information concerning one or more priority claims considered void

(54) Title: LIGHT COLLIMATING SYSTEM FOR SCHMIDT-CASSEGRAIN TELESCOPE



WO 2008/109563 A2

FIG. 4

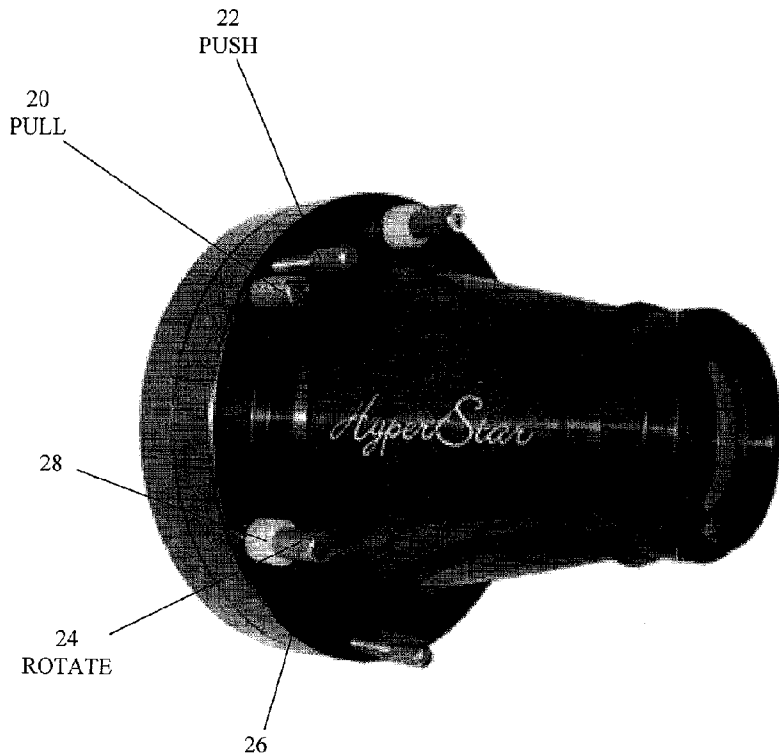

(57) Abstract: Disclosed is a light collimating system for mounting at the primary focus of a Schmidt-Cassegrain telescope (SCT) in place of the secondary mirror. The system comprises a housing containing a plurality of lens elements optimized to reduce optical aberrations. The resulting system has a focal ratio of approximately f/2, a short exposure time for optical imaging, and a wide field of view with very little distortion. The housing is attached to the SCT by a pair of rings held together by a plurality of screws that further facilitate the alignment and rotation of the light collimating system.

1 second plate of different material (an “achromatic corrector plate”) at the center of
2 curvature of the spherical mirror.

3 In a number of applications requiring broader spectral coverage, the difficulty in
4 correcting chromatic aberration, and the limitations in materials tend to reduce the
5 effectiveness of the Schmidt plate correction concept. As a result, systems requiring
6 broad band coverage and wide field of views have tended to use purely reflective designs
7 (which eliminate the problem of chromatic aberration). Some of these systems use the
8 Schmidt principle, with the aspheric deformation applied to a mirror, rather than to
9 refractive plate. These systems generally involve off-axis apertures and/or off-axis fields
10 of view, resulting in relatively larger system sizes. In all cases however, the aspheric
11 surface has been rotationally symmetric, whether placed on a flat or curved folding
12 mirror. For a detailed description of these prior design concepts, see I. R. Abel and M.
13 R. Hatch, “The Pursuit of Symmetry in Wide-Angle Reflective Optical Design,” Proc.
14 1980 International Lens Design Conference, SPIE Vol. 237, p. 271 (1980).

15 The foregoing discussion of the prior art derives primarily from U.S. Patent No.
16 4,576,452 which proposes to utilize in a reflective Schmidt or Schmidt-Cassegrain
17 system configuration a corrector mirror in the form of a tilted nonrotationally symmetric
18 aspherized mirror placed between the optical system and the target of interest, generally
19 at or near the center of curvature of the primary focusing mirror. According to the
20 inventors, the corrector mirror encodes both the correction for traditional aberrations
21 associated with the Schmidt designs, as well as the wavefront error introduced by tilting
22 the fold mirror.

23 One way to enlarge the field of view is to use a camera with a larger sensor, but
24 these are very expensive. Another way is to use a telescope with a shorter focal length,
25 such as a refractor, but these are generally much smaller telescopes. Further, high
26 quality refractor telescopes suitable for imaging can be quite expensive, and their smaller
27 apertures restrict the resolution and limiting magnitude of the system. Finally, the focal
28 ratio of a small refractor is typically $f/5$ to $f/7$, but still long enough to require an
29 equatorial mount and guide camera.

30 Even with a larger sensor in the camera, there are many potential issues
31 remaining. For instance, many telescopes do not produce sharp stars very far off axis.
32 Most SCTs experience coma, and all SCTs have field curvature. Thus, while the field of
33 view might be reasonably large with a big sensor, the star images will not be ideal.

1 The amount of sky one can capture in an image is partially dependent on the focal
2 length of the telescope used and the size of the sensor in the camera. A big field of view
3 is a definite advantage because most deep-sky objects are quite large.

4 One solution is to collect image data at the focal point of the primary mirror
5 (prime focus). A typical Schmidt-Cassegrain telescope uses a primary mirror which has
6 a focal ratio of around $f/2$ and a secondary mirror which provides a 5x magnification,
7 yielding an overall focal ratio of $f/10$. Because of the focal length, the amount of
8 exposure time required to collect enough light for a useful image necessitates polar
9 alignment and the guiding of the SCT to follow the target across the sky as the earth
10 rotates. Removal of the secondary mirror converts the telescope to a focal ratio of
11 approximately $f/2$. Because the exposure time required for this focal length is much
12 shorter, the telescope does not need to be polar aligned, nor is guiding necessary. The
13 magnification lost in the secondary mirror is not useful for viewing unresolved objects
14 such as stars.

15 U.S. Patent No. 6,857,265 suggests collecting data at the prime focus of a
16 telescope. The system used in this prior art reference is large and complex, being
17 designed primarily for very large telescopes. Because of the large size and weight, the
18 system includes an adjustment mechanism to correct the relative position of the
19 apparatus as the telescope moves. This adjustment mechanism, which comprises a series
20 of six jacks called a Stewart platform, adds to the complexity of the system.

21 Moreover, the prior art includes no means for correcting optical aberrations that
22 may occur as a result of the primary mirror. Removal of the secondary mirror, without
23 providing a corrective lens, produces very poor images at the prime focus. The primary
24 mirror alone generally suffers from spherical aberration and field curvature which is
25 normally minimized by the secondary mirror.

26 The present invention provides light collimating optical system which replaces
27 the secondary mirror at the front end of a Schmidt-Cassegrain telescope (SCT). The
28 optical system of the present invention, as seen in Fig. 2, comprises multiple lens
29 elements that may be customized for a specific Schmidt-Cassegrain design contained
30 within a housing having a simple alignment design. Moreover, these lens elements
31 correct the inherent aberrations in the telescope, allowing focal ratios of approximately
32 $f/2$ or $f/1.8$ with a highly-corrected field of view.

1 The present invention works with Schmidt-Cassegrain telescopes and is
2 particularly well-suited for such telescopes in which the secondary mirror may be easily
3 removed and replaced with the apparatus of the present invention.

4 One advantage of the present invention is the increased field of view. The optical
5 system of the present invention corrects for aberrations such as coma and field curvature,
6 producing a very wide field of view with very sharp stars across the entire field. The
7 result is a wider field of view, even with a small camera, and finer star images.

8 Another advantage of the present invention is the potential for unguided imaging.
9 Long exposures usually require a telescope to be guided due to inherent tracking errors
10 in the drive. This requires a second camera or self-guiding camera and often other
11 hardware such as a guidescope. Because the necessary exposure time is much lower for
12 telescopes equipped with the light collimating system of the present invention, guiding,
13 and related hardware are not required. In addition, the present invention makes it
14 possible to image with a telescope in alt-azimuth mode. This means it is possible to
15 capture deep-sky images with a fork-mounted SCT without the need for an equatorial
16 wedge. In addition to cost, this saves the trouble of mounting the scope on a wedge and
17 having to polar align the telescope.

18 Further features and advantages of the present invention will be seen from the
19 following detailed description, taking in conjunction with the accompanying drawings,
20 wherein:

21 **Fig. 1** schematically illustrates a conventional Schmidt-Cassegrain telescope;

22 **Fig. 2** schematically illustrates a Schmidt-Cassegrain telescope with a light
23 collimating system of the present invention mounted thereon;

24 **Fig. 3** is a cross-sectional view of the light collimating system of the present
25 invention;

26 **Fig. 4** is an illustration of the light collimating system of the present invention
27 showing external screws used to align the system;

28 **Figs. 5A and 5B** are end and side cross-sectional views of a mounting ring
29 element;

30 **Figs. 6A and 6B** are end and side cross-sectional views of an adapter ring
31 element;

32 **Fig. 7** is a view of the several optical elements making up the light collimating
33 system according to one embodiment of the present invention;

1 **Figs. 8A and 8B** are end and side cross-sectional views of the housing element;
2 **Figs. 9A and 9B** are end and side cross-sectional views of a primary lens retainer
3 element;

4 **Figs. 10A and 10B** are end and side cross-sectional views of a secondary lens
5 retainer of the present invention;

6 **Figs. 11A and 11B** are end and side cross-sectional views of a retainer ring
7 element;

8 **Fig. 12** is an illustration of a counterweight used in connection with the light
9 collimating system of the present invention;

10 **Fig. 13** is an illustration of a charge-coupled device camera installed with the
11 light collimating system of the present invention;

12 **Fig. 14** is a side cross-sectional view of a filter and spacer according to an
13 alternative embodiment of the present invention;

14 **Fig. 15** is a cross-sectional view of the light collimating system in accordance
15 with one embodiment of the present invention; and

16 **Fig. 16** is a cross-sectional view of the light collimating system in accordance
17 with one embodiment of the present invention.

18 The present invention provides a light collimating system that replaces the
19 secondary mirror at the primary focus of a Schmidt-Cassegrain telescope (SCT). A key
20 to the present invention involves a simple, easy to use, adjustable collimating lens
21 assembly that permits both rotational and tilt adjustments to correct alignment errors.

22 Referring to the Figs. 3 and 4, a light collimating system includes a housing 8 in
23 which is mounted an optical lens assembly as will be described in detail later. The
24 housing 8 comprises a generally conically-shaped body rotatably mounted in an adapter
25 ring 5. Adapter ring 5 in turn is mounted to a mounting ring 1 via pull screws 20 that
26 extend through holes 27 in adapter ring 5 where they are threadedly mounted into
27 threaded holes 28 in mounting ring 1, which are shown in detail in FIGS 5A, 5B, 6A and
28 6B.

29 Referring in particular to Fig. 4, pull screws 20 are located on a periphery of
30 adapter ring 5 spaced 120° apart. The adapter ring is shown in detail in Figs. 6A and 6B.
31 Push screws 22 are located adjacent pull screws 20. Push screws 22 are threadedly
32 mounted in holes 23 (see Fig. 6B) in adapter ring 5 and are also spaced 120 degrees
33 around the periphery of adapter ring 5. Push screws 22 and pull screws 20 are adjusted

1 in tandem, providing a simple means for aligning the axis of the light collimating system
2 with that of the primary mirror.

3 A third set of fixing screws 24 are threadedly mounted into holes 25 in adapter
4 ring 5, located on the periphery of adapter ring 5 and equi-spaced between pull screws 20
5 (see Figs. 6A and 6B). Each fixing screw 24 includes a head 26 that is sized to contain a
6 bushing 28 that in turn is sized and shaped to bear down on a flange 15 formed integrally
7 at the proximal end of housing 8 when fixing screw 24 is screwed down. Fixing screws
8 24 permit rotational alignment of the housing 8 of the light collimating system.
9 Alternatively, the housing may be constructed of two portions wherein only an upper
10 portion of the housing is permitted to rotate.

11 The light collimating system includes a series of lens elements for correcting
12 optical aberrations. Some of these aberrations are normally corrected by the spherical
13 secondary mirror. As shown in Fig. 7, the series of lens elements will be arranged
14 concentrically and will generally include a doublet 7, comprising two lenses A, B of two
15 different materials that are bonded together to form a single lens, a second lens element
16 3, and a third lens element 6.

17 The achromatic doublet 7 corrects for chromatic aberration caused by difference
18 in refractive index for different wavelengths of light. The doublet is bonded together
19 using suitable cements known in the relevant art, such as NORLAND 61. One of the air-
20 glass surfaces of the doublet may be a flat surface and at least one of the surfaces will be
21 concave. Lenses 71 and 72, forming the doublet, will usually have the same diameter.
22 Doublet 7 is held in place between first retainer ring 9, which and first shelf 12, formed
23 on the inner wall of the housing 8. The housing is shown in detail in Figs. 8A and 8B
24 and the first retainer ring is shown in detail in Figs. 9A and 9B.

25 The second lens element 3 further collimates the light after it passes through the
26 doublet and is usually a meniscus lens constructed of a third material. The concave side
27 of the second lens element 3 is beveled flat at the edges to rest against spacer 2 (as
28 shown in Fig. 3). The second lens element 3 is also held in place on the convex side by
29 second retainer ring 4. The second retainer ring is shown in detail in Figs. 10A and 10B.

30 The third lens element 6 focuses the light into the charge-coupled device (CCD)
31 camera. The third lens element 6 may be a bi-convex lens or maybe comprised of a
32 doublet formed of two lenses of different materials, similar to doublet 7, save that both
33 air-glass surfaces are convex. The third lens element 6 lens is held in place between

1 spacer 2 and a second shelf 14 of housing 8. The spacer is shown in detail in FIGS 11A
2 and 11B. One or both surfaces of the third lens element 6 may include flat beveled
3 portions at the edges for convenience of assembly with the spacer and housing second
4 shelf.

5 The air-glass surfaces of all lens elements should be coated with an anti-reflective
6 material to minimize further aberrations. As shown in Fig. 7, the light collimating
7 system may also include a filter 35 and a glass window 38 between the bi-convex lens
8 and the CCD camera. Moreover, additional lenses may be included to further correct the
9 light before entering the CCD camera if required for a particular SCT design.

10 Depending on the size and design of the telescope, the focal ratio of the telescope
11 with the light collimating system of the present invention installed will be between $f/1.8$
12 and $f/2.0$. With the light collimating system of the present invention installed, high
13 quality images may be obtained up to 31 times faster than imaging at a typical focal ratio
14 of $f/10$.

15 Removing the secondary mirror and installing the light collimating system is very
16 simple according to the present invention. First, the user points the telescope up at about
17 a 45° angle. If using an equatorial mount, the user will simply put the telescope in the
18 normal home position. This position keeps the mirror and lenses from falling out during
19 installation. The user should tighten the clutches to hold the telescope in place.

20 The secondary mirror is easily removed from the corrector plate at the front of the
21 telescope and placed into a holder for protection. The light collimating system lens is
22 then threaded onto the front of the telescope in place of the secondary mirror. The
23 charge-coupled device (CCD) camera 30 is threaded onto the light collimating system.
24 See Fig. 13. If desired, the orientation of the camera can be changed by loosening
25 slightly the three fixing screws 24, turning the camera to the desired orientation, and
26 retightening the screws. For larger SCTs, e.g., at least 14 inches, the system is
27 compatible with digital single-lens reflex cameras (SLRs). A counterweight 28 is
28 installed at the back of the telescope to balance the weight of the light collimating system
29 and camera. See Fig. 12.

30 Usually, most SCTs are equipped with a large retaining ring from the front of the
31 telescope which must be removed before the secondary mirror assembly can be removed
32 and placed in the protective holder. The large retaining ring may then be threaded onto
33 the protective holder to prevent the secondary mirror from falling out. The secondary

1 mirror is indexed such that when it is replaced in the telescope, collimation is retained
2 and no adjustments are necessary.

3 The telescope must then be balanced properly to avoid problems during imaging
4 or pointing of the telescope. On a fork-mounted telescope, the counterweight is slid
5 either front to back or back to front to balance the scope. On a German equatorial
6 mount, the optical tube itself is repositioned for balance.

7 With the light collimating system installed, pointing of the telescope is done
8 using the computer. The camera is run in a low-resolution mode that takes and
9 downloads a new image every second or two. In this way you get an almost real-time
10 view of where the telescope is pointing. Focusing with light collimating system is easy
11 and can be done manually or automatically.

12 Finding the desired object is also simplified by the present invention. Images
13 may be taken every few seconds and loaded to the computer screen. With just a 1-
14 second exposure, the light collimating system with a typical CCD camera is sensitive
15 enough to allow the camera to pick up almost any deep sky object. In the case of an
16 extremely faint target, the exposure may have to be increased to 5 seconds. Once the
17 object has been located by the telescope, the target object can be framed as desired by
18 either moving the telescope with the directional buttons on the hand control or by
19 rotating the camera using the fixing screws.

20 Collimating adjustments need only be made if there is a noticeable coma effect
21 (flaring of the star images to one side) on one edge or corner of the field while the rest of
22 the stars appear sharp. This implies the primary mirror is slightly tilted and not perfectly
23 aligned with the optical axis of the light collimating system. This is normally
24 compensated for by adjusting the secondary mirror, but with the mirror removed the
25 coma effect is diminished by properly aligning the light collimating system. This is done
26 by taking a single short exposure of a star field and then by simply adjusting one set of
27 the push screws 22 and pull screws 20. This will tip one side of the light collimating
28 system outward. A second image will reveal if the collimation was successful. If no
29 improvement is seen, a different pair of push and pull screws should be adjusted. It may
30 be necessary to refocus during adjustment to see the best results.

31 A variety of cameras will work with the light collimating system, but there are
32 some limitations. The camera cannot be too large or it will obstruct too much of the
33 telescope aperture. Thus it follows that, larger telescopes can use larger cameras. Also,

1 the size of the sensor that can be fully illuminated by the light collimating system is
2 dependent on the size of the telescope. Larger scopes allow larger lens elements to be
3 used in the light collimating system, allowing bigger sensors to be illuminated.

4 Imaging with a one-shot color model eliminates the need to take individual red,
5 green, and blue-filtered exposures to create a color image. The color rendition obtained
6 from a one-shot color camera is very accurate. While color cameras tend to be less
7 sensitive than monochrome models, there are two aspects of the present invention that
8 make this difference less significant. First, the total time spent imaging is not increased
9 because the color camera does not require as many images. Second, and most
10 importantly, is that the exposure times are so short with the light collimating system that
11 any overall time difference is minimized. Even where narrowband imaging is desired to
12 provide greater detail, exposures are still only a few minutes long, instead of the hours it
13 might take with a much slower system.

14 Flat field images are not generally required with the light collimating system, but
15 may be useful to remove vignetting that may occur due to the fast focal ratios.

16 It is possible to use a filter, such as a 1.25 inch Hydrogen-Alpha (H-alpha) or
17 Light Pollution Reduction (LPR) filter 35, with the light collimating system. Referring
18 to Fig. 14, the filter is placed inside a camera spacer 32 and rests on the second shelf 14
19 retaining the third lens element 6 in the light collimating system. The threads should
20 point toward the CCD camera for correct orientation. It is important to note that systems
21 with very fast focal ratios usually require a wider bandpass than narrowband filters.

22 The invention is described below in reference to installation on commercially
23 available Schmidt-Cassegrain telescopes (SCTs) with readily replaced secondary
24 mirrors. The lenses are preferably customized for each specific design as slight
25 differences in design, such as the primary mirror, must be compensated for in the lenses
26 of the present invention.

27 **Example 1**

28 The present invention was optimized and assembled with an 14 inch
29 CELESTRON® SCT and is shown in Fig. 7. The optical assembly comprised four
30 lenses, a filter, and a flat glass window. The first lens 71 is biconcave and the second
31 lens 72 is plano-convex. Lenses 71 and 72 are bonded together forming a doublet. Lens
32 A includes a flat bevel 77 on the weaker face for resting against the first retainer ring.
33 Line 70 indicates the position relative to the corrector plate of the SCT. Middle lens 3 is

1 a negative meniscus lens with a flat beveled edge 75 having 0.5 mm wide. Final lens 6 is
 2 a bi-convex lens with a flat beveled edge 78 having 0.5 mm wide. The materials from
 3 which each lens is made and the radius of each lens surface is listed in Table 1. The
 4 distance from the front surface of lens 71 to the CCD camera is 65.8 mm. Attaching the
 5 light collimating system to the 11 inch CELESTRON® SCT reduces the focal ratio from
 6 f/11 to f/1.9. Equivalent exposure times were reduced by a factor of 28. When used
 7 with a CANON EOS® 20Da camera, the field of view covered 1.91° x 1.27° with a
 8 resolution of 1.95 arc-seconds/pixel.

Lens	Radius	Thickness	Diameter	Material
Lens 71	-334.7°; 106.45°	8 mm	88 mm	S-BSL7
Lens 72	106.45°; infinity	13 mm	86 mm	S-TIM2
Middle Lens 3	129.46°; 71.94°	6 mm	68 mm	S-TIH4
Final Lens 6	106.45°; -238°	11 mm	62 mm	S-BSL7

9 **Table 3: Light Collimating System Lenses for the 14 inch CELESTRON® SCT**

10 **Example 2**

11 The present invention was optimized and assembled with an 8 inch
 12 CELESTRON® SCT. The optical assembly comprised five lenses, a filter, and a flat
 13 glass window. As shown in Fig. 15, the first lens 81 is plano-concave and the second
 14 lens 82 is a positive meniscus. Lenses 81 and 82 are bonded together forming a doublet.
 15 The position of the light collimating system is such that the front face of lens 81 is 13
 16 mm inside of the corrector plate. Middle lens 83 is a negative meniscus lens with a flat
 17 beveled edge 88 having 0.5 mm wide. Final doublet 86 is comprised of two lenses.
 18 Lens 86A is a biconvex lens with a flat beveled edge 89 having 0.5 mm wide and lens
 19 86B which is a negative meniscus. The materials from which each lens is made and the
 20 radius of each lens surface is listed in Table 2. The distance from the front surface of
 21 lens 81 to the CCD camera is 35 mm. Attaching the light collimating system to the 11
 22 inch CELESTRON® SCT reduces the focal ratio from f/10 to f/2.1. Equivalent
 23 exposure times were reduced by a factor of 25.0.

Lens	Radius	Thickness	Diameter	Material
Lens 81	infinity; 51.23°	5 mm	48 mm	S-BSL7
Lens 82	51.23°; 143.1°	8 mm	48 mm	PBM2
Middle Lens 83	80.88°; 51.23°	4 mm	42 mm	PBH4

Lens 86A	63.7°; -63.7°	9 mm	40 mm	S-BSL7
Lens 86B	-63.7°; -154.69°	3 mm	40 mm	PBM2

Table 2: Light Collimating System Lenses for the 8 inch CELESTRON® SCT

Example 3

The present invention was optimized and assembled with an 11 inch CELESTRON® SCT. The optical assembly comprised four lenses, a filter, and a flat glass window. As shown in Fig. 16, the first lens 91 is biconcave and the second lens 92 is plano-convex. Lenses 91 and 92 are bonded together forming a doublet. Lens 91 includes a flat bevel 95 on the front face. Line 90 indicates the position relative to the corrector plate of the SCT. Middle lens 93 is a negative meniscus lens with a flat beveled edge 98 having 0.5 mm wide. Final lens 96 is a biconvex lens with a flat beveled edge 99 having 0.5 mm wide. The materials from which each lens is made and the radius of each lens surface is listed in Table 1. The distance from the front surface of lens 91 to the CCD camera is 51.9 mm. Attaching the light collimating system to the 11 inch CELESTRON® SCT reduces the focal ratio from f/10 to f/1.8. Equivalent exposure times were reduced by a factor of 30.9.

Lens	Radius	Thickness	Diameter	Material
Lens 91	-387.9°; 124.42°	5 mm	74 mm	S-BSL7
Lens 92	124.42°; infinity	10 mm	74 mm	S-TIM2
Middle Lens 93	136.94°; 62.49°	5 mm	58 mm	S-TIH4
Final Lens 96	79.5°; 176°	11 mm	58 mm	S-BSL7

Table 1: Light Collimating System Lenses for the 11 inch CELESTRON® SCT

It should be emphasized that the above-described embodiments of the present system are merely possible examples of implementations and merely set forth for a clear understanding of the principles of the invention. Many different embodiments of the light collimating system described herein may be designed and/or fabricated without departing from the spirit and scope of the invention. All these and other such modifications and variations are intended to be included herein within the scope of this disclosure and protected by the following claims. Therefore the scope of the invention is not intended to be limited except as indicated in the appended claims.

1 **CLAIMS**

- 2 1. A light collimating system for mounting at the focus of a primary mirror of
3 a Schmidt-Cassegrain telescope, comprising:
4 a housing with a distal end designed for the attachment of an optical imaging
5 device;
6 a plurality of lens elements contained within the housing and arranged
7 concentrically about the axis of the primary mirror, wherein at least one lens element
8 comprises an achromatic doublet;
9 an adapter ring attached to the housing; and
10 a mounting ring attached to the adapter ring by a set of screws.
- 11 2. The system of claim 1, wherein the light collimating system replaces the
12 secondary mirror of a Schmidt-Cassegrain telescope.
- 13 3. The system of claim 1, wherein the plurality of lens elements includes a
14 first lens element, a second lens element, and a third lens element, the first lens element
15 comprising an achromatic doublet.
- 16 4. The system of claim 1, wherein the plurality of lens elements are optimized
17 to reduce optical aberrations.
- 18 5. The system of claim 1, wherein the housing includes a first shelf, and
19 wherein said first lens element is held between said first shelf and a first retaining ring.
- 20 6. The system of claim 1, further comprising a second shelf at the back end of
21 said housing, a spacer and a second retaining ring, wherein the second lens element is
22 held in place between the second retaining ring and the spacer, and wherein the third lens
23 element is held in place between the spacer and the second shelf.
- 24 7. The system of claim 1, wherein one or more of the lens elements are
25 beveled flat on the edge of at least one side.
- 26 8. The system of claim 1, further comprising a filter.
- 27 9. The system of claim 8, further comprising a spacer between the housing and
28 the optical imaging device, wherein the filter is held against the distal end of the housing
29 by the spacer.
- 30 10. The system of claim 1, wherein the optical imaging device is a charge-
31 coupled device camera.
- 32 11. The system of claim 10, wherein the optical imaging device is a digital
33 single-reflex camera.

1 12. The system of claim 1, wherein the Schmidt-Cassegrain telescope with
2 the light collimating system has a focal ratio of about $f/2$.

3 13. A light collimating system for a Schmidt-Cassegrain telescope,
4 comprising:
5 a housing mounted in place of a secondary mirror of the telescope, the housing
6 containing a plurality of lens elements, wherein the housing at a distal end is designed
7 for the attachment of an optical imaging device;
8 an adapter ring attached to the housing;
9 a mounting ring attached to the adapter ring by a first set of screws; and
10 a second set of screws placed for maintaining the relative positions of the
11 mounting ring and the adapter ring, the first set of screws and second set of screws
12 forming a means of aligning the axis of the plurality of lens elements with the axis of the
13 primary mirror of the telescope.

14 14. The system of claim 13, further comprising a third set of screws which
15 allow the housing to rotate about the axis when loosened.

16 15. A Schmidt-Cassegrain telescope having installed thereon a light
17 collimating system as claimed in claim 1.

18 16. A Schmidt-Cassegrain telescope having installed thereon a light
19 collimating system as claimed in claim 13.

20

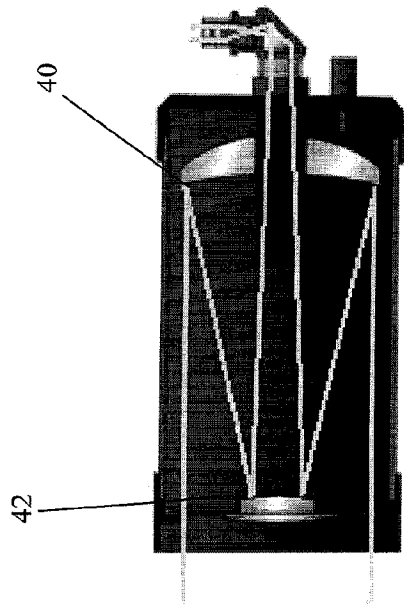

FIG. 1

PRIOR ART

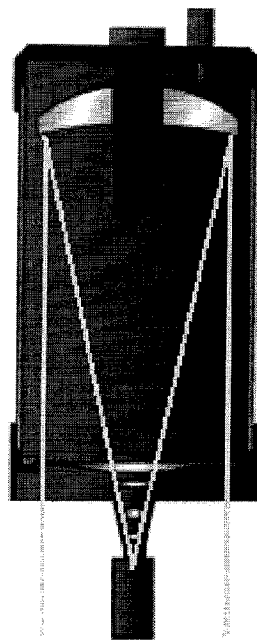

FIG. 2

FIG. 3

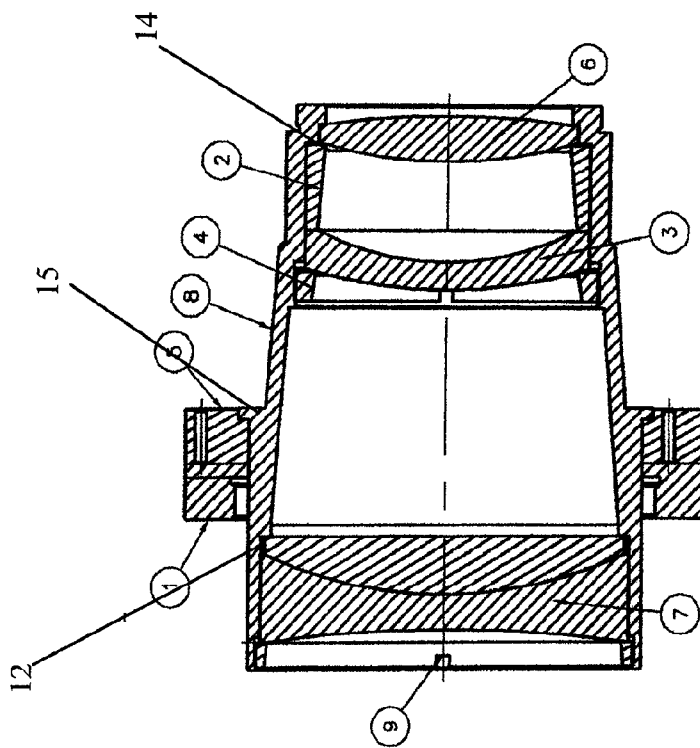
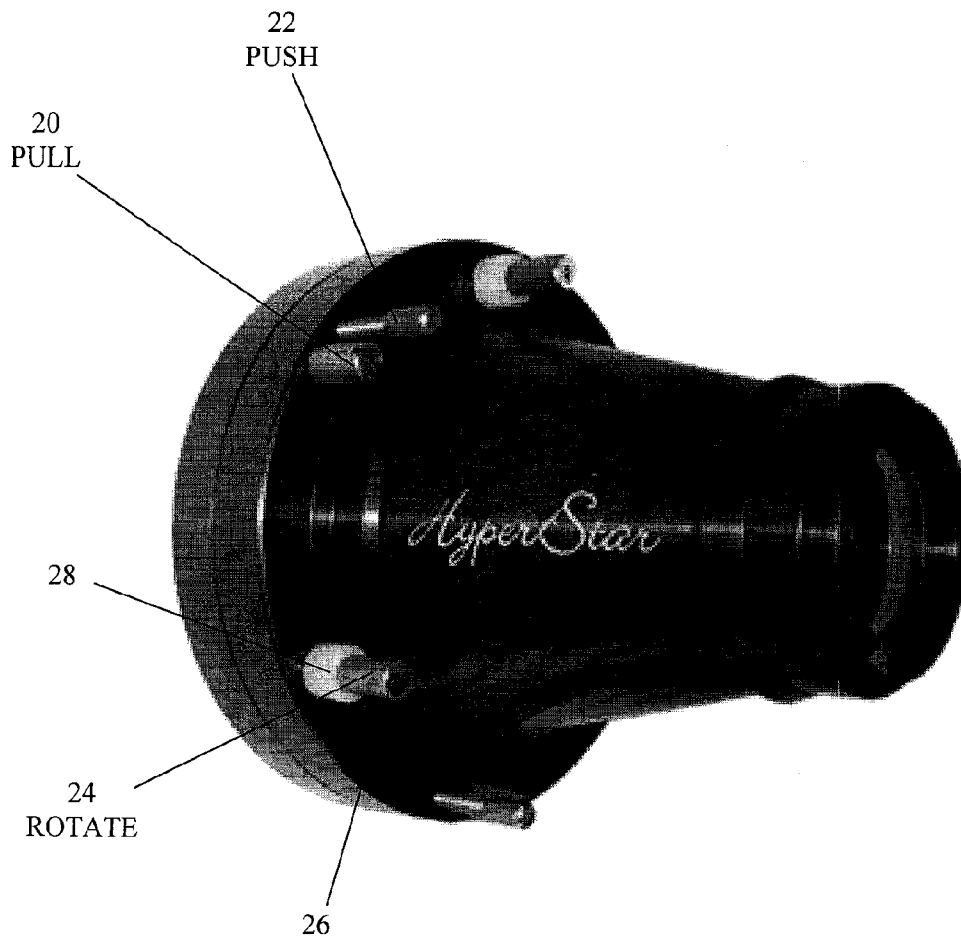

FIG. 4



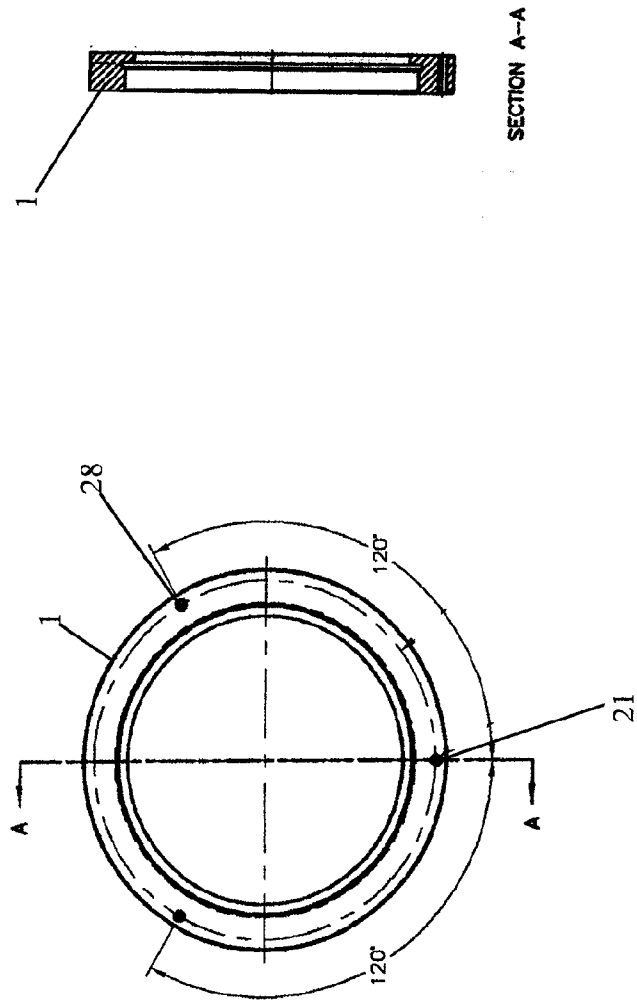

FIG. 5B

FIG. 5A

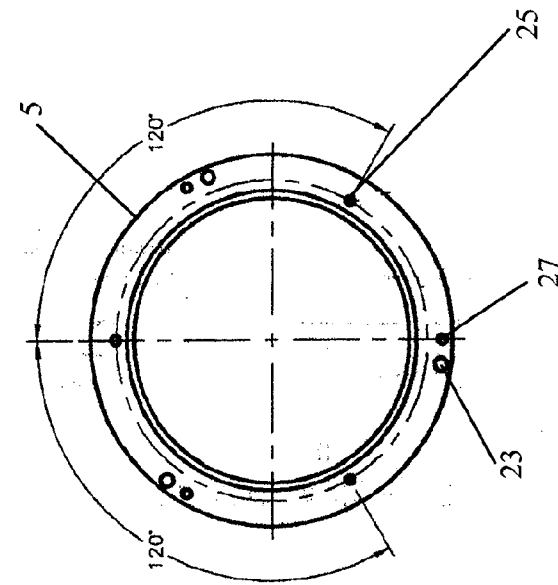
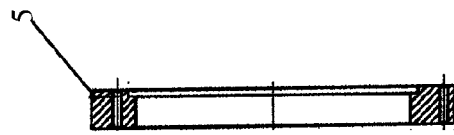

FIG. 6B



SECTION A-A

FIG. 6A

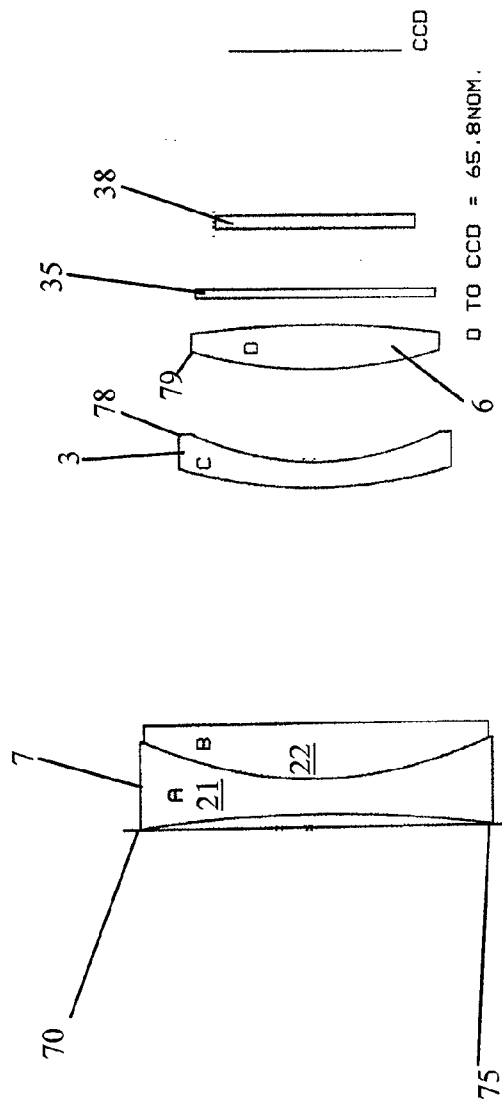
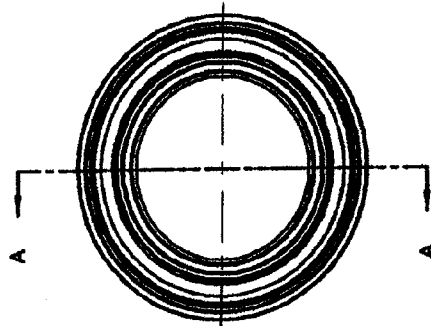
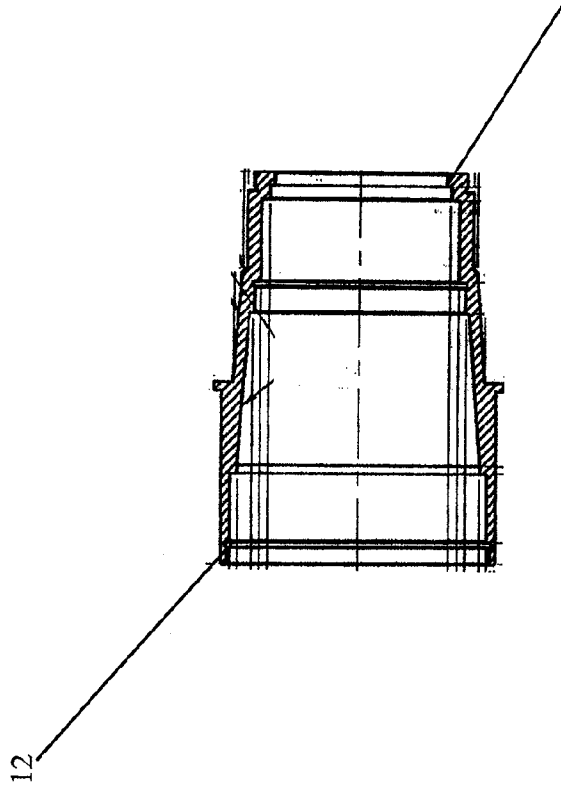

FIG. 7



SECTION A-A

FIG. 8B

FIG. 8A

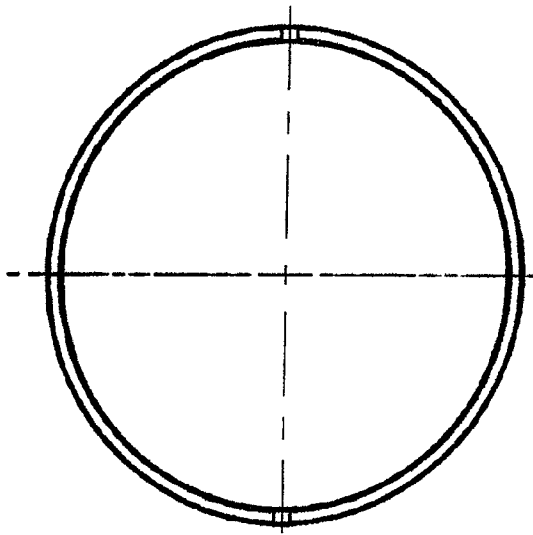

Fig. 9A

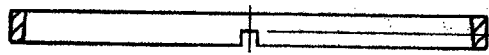

Fig. 9B

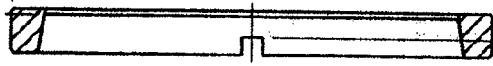

Fig. 10B

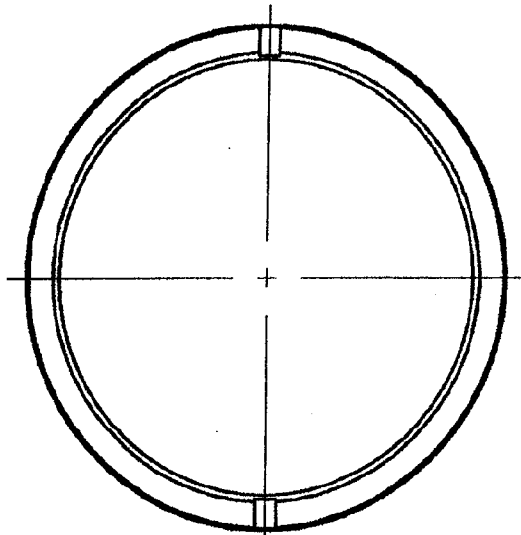

Fig. 10A

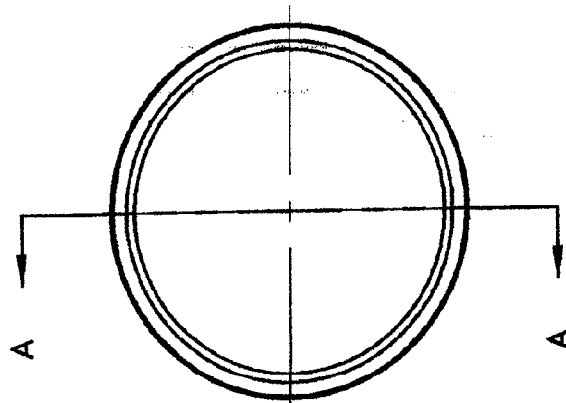
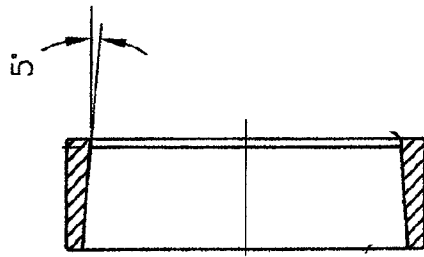

FIG. 11A



SECTION A-A

FIG. 11B

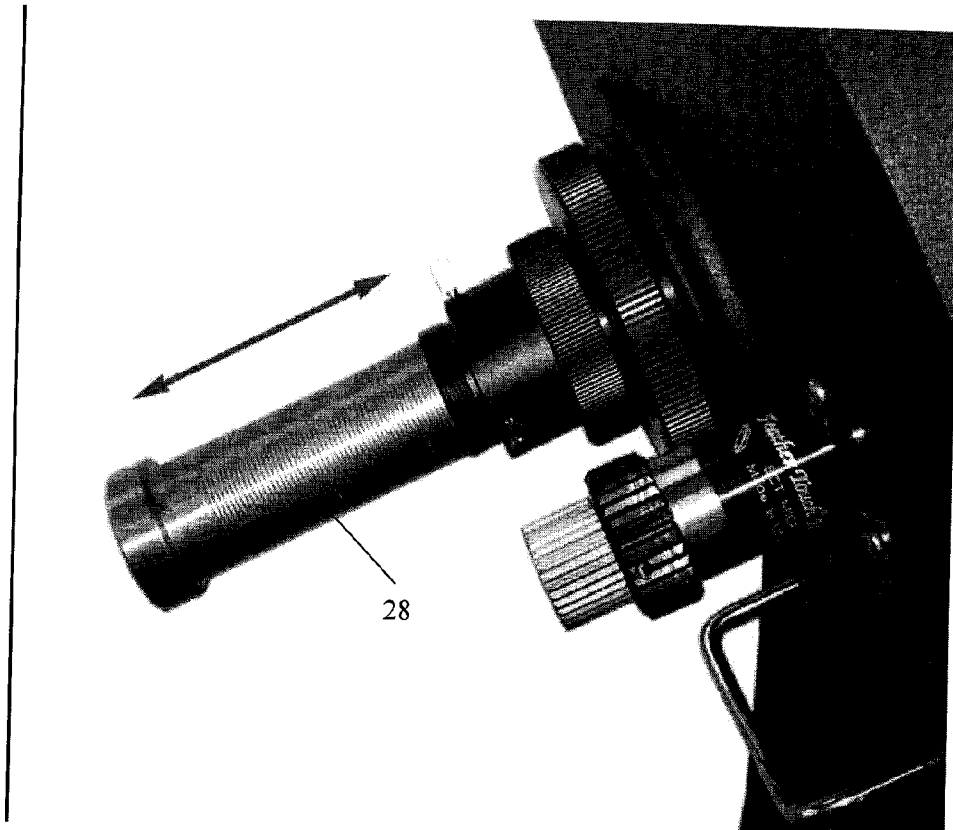

FIG. 12

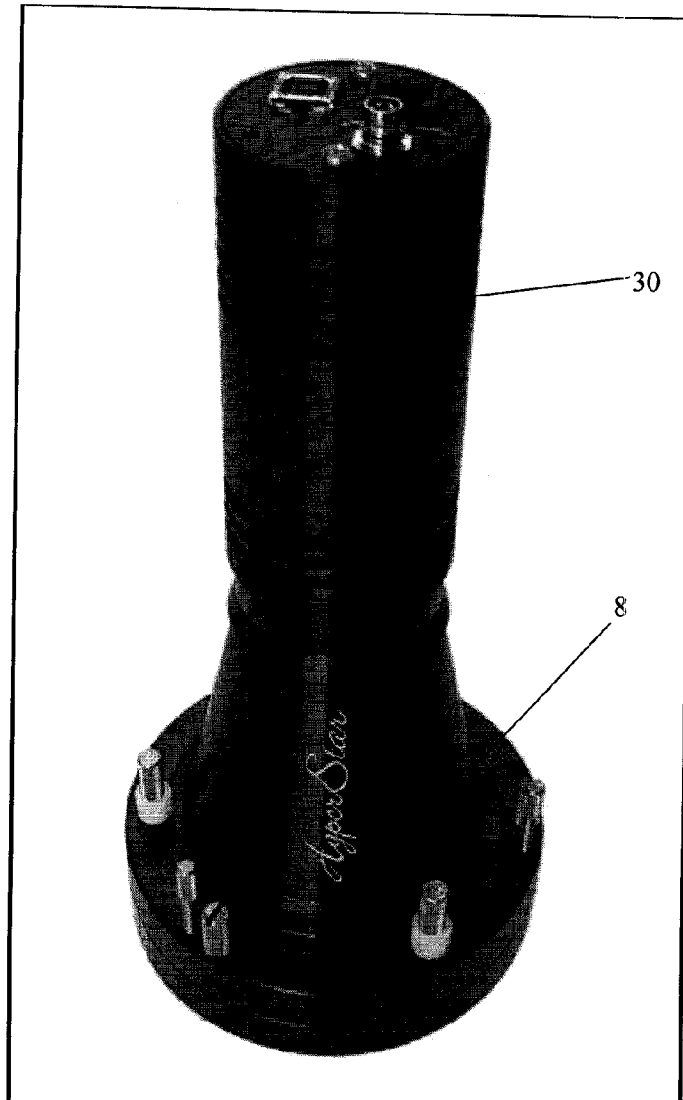

FIG. 13

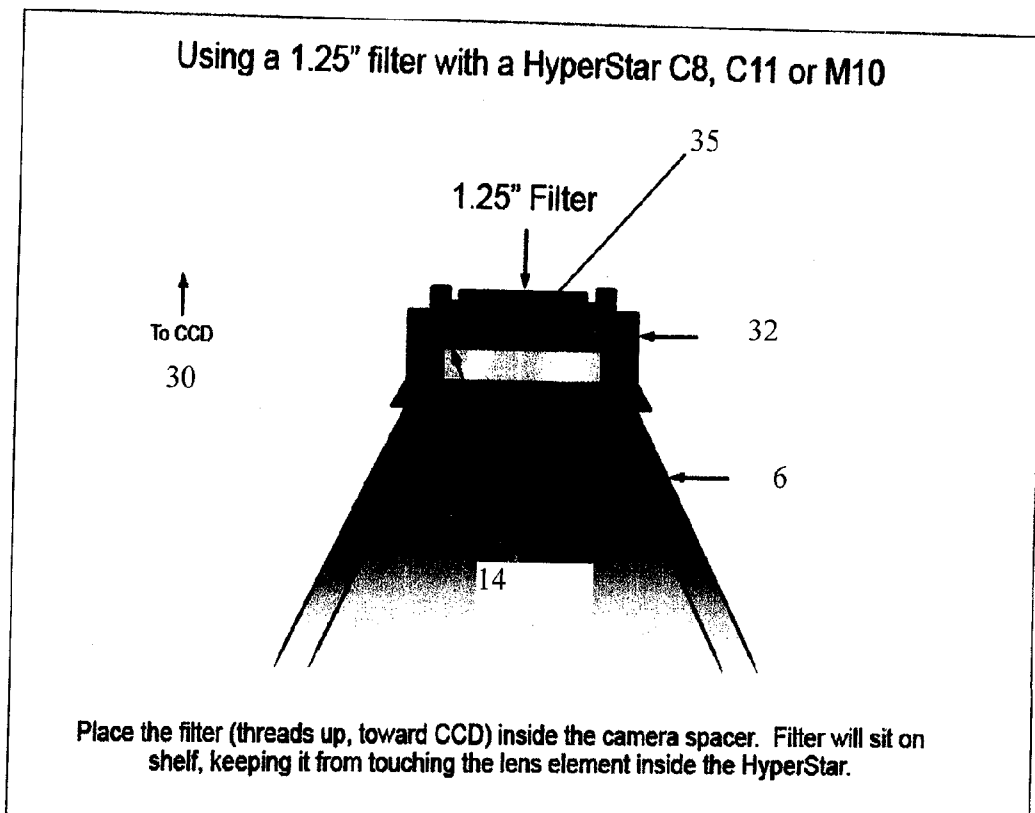

FIG. 14

