



HU000027425T2

(19) **HU**(11) Lajstromszám: **E 027 425**(13) **T2****MAGYARORSZÁG**
Szellemi Tulajdon Nemzeti Hivatala**EURÓPAI SZABADALOM**
SZÖVEGÉNEK FORDÍTÁSA

- (21) Magyar ügyszám: **E 09 305244**
- (22) A bejelentés napja: **2009. 03. 17.**
- (96) Az európai bejelentés bejelentési száma:
EP 20090305244
- (97) Az európai bejelentés közzétételi adatai:
EP 2103218 A1 **2009. 09. 23.**
- (97) Az európai szabadalom megadásának meghirdetési adatai:
EP 2103218 B1 **2015. 06. 03.**
- (51) Int. Cl.: **A21C 3/04** (2006.01)
A21C 5/00 (2006.01)

- | | |
|--|---|
| (30) Elsőbbségi adatok:
0851774 2008. 03. 19. FR | (73) Jogosult(ak):
MECATHERM, Société Anonyme, 67130
Barembach (FR) |
| (72) Feltaláló(k):
Zorn, Bernard, F - 67700, Saverne (FR) | (74) Képviselő:
Ivánka Gábor, ARINOVA Szabadalmi és
Védjegy Iroda, Budapest |

- (54) **Garat, amely magában foglal egy készüléket sütődei tészta, sütemény tészta vagy hasonlók áramlásának elősegítésére egy fal mentén**

Az európai szabadalom ellen, megadásának az Európai Szabadalmi Közlönyben való meghirdetésétől számított kilenc hónapon belül, felszólalást lehet benyújtani az Európai Szabadalmi Hivatalnál. (Európai Szabadalmi Egyezmény 99. cikk(1))

A fordítást a szabadalmas az 1995. évi XXXIII. törvény 84/H. §-a szerint nyújtotta be. A fordítás tartalmi helyességét a Szellemi Tulajdon Nemzeti Hivatala nem vizsgálta.

The invention relates to a hopper comprising a device to enhance the gravity flow of dough for bakery products, for Viennese pastry or the like, along a wall for feeding a downstream processing device, in particular a volumetric dough divider.

The present invention belongs to the field of the preparation and the handling of dough for bakery products, for Viennese pastry, for pastries or the like. The invention concerns more particularly the flow of a dough of this type along a surface of a hopper.

In the bakery industry, the devices for the transportation, storage and processing of the dough, for example a device for dividing the dough into dough pieces, hereinafter referred to as a divider, are frequently fed through a hopper into which the dough is poured, in particular from a mixer. The hopper serves, therefore, to contain the dough inside it, wherein the dough flows gradually and is reloaded regularly.

The major disadvantage of the dough feed to the divider is specifically its flow along the walls of the feed container.

In fact, it is necessary to lubricate the walls of the container regularly to ensure a good flow of the dough to the downstream processing device.

In this context, a method of dividing dough volumetrically and its implementation device are known, for example, from document FR 2902293 A. As regards the said device, it comprises a hopper for containing the dough to be divided and is provided in its lower part with an opening communicating with a feed chamber capable of calibrating the amount of dough to be divided. In particular, the divider comprises means for cutting into pieces the amount of dough calibrated in the feeding chamber. Moreover, it comprises means for turning the feed chamber to discharge of the dough pieces on to a discharge surface.

In this, each compartment of the feed chamber comprises a piston intended not only to enhance the mechanical ejection of the dough pieces from their respective compartment, but also to assist in the calibration of the quantity of dough contained in the feed chamber.

It has been recognised that the one operation which is the longest in a complete cycle where the dough is divided into dough pieces is the filling of the feed chamber which is done by gravity flow of the dough from the feed hopper.

In document FR 2902293 A, the disadvantages of using free flow to fill the feed chamber with dough were highlighted.

In fact, a method is known to move the dough by suction at the bottom of the feed hopper wherein the dough is forced by the action of the pistons into the feed chamber. Once the amount of dough is drawn in, a knife cuts the dough in the bottom part of the hopper while closing the feed chamber in which a calibration operation then starts by compressing the dough contained in it.

It has been demonstrated that this technology has the effect of subjecting the dough to high stresses which results in a not insignificant increase in its density. In addition, the stresses stored in the dough, a material having elasticity and shape memory, emerge again when working with the dough pieces causing irregularity in the products obtained.

This technology has another disadvantage, namely the appreciable power required to provide suction and to compress the dough, this because of the resistance of the latter.

Also, the dividers, designed up to now according to this operating principle, comprised a limited number of pistons and only permitted a small number of dough pieces to be delivered during one dividing cycle.

Consequently, these known volumetric dividers were necessarily limited in their production rate.

The solution proposed by the document FR 2902293 A differs in that respect. By actually leaving the dough to flow freely in the feed chamber, the latter requires no power to fill it. Its dimensions can be substantial and, in each dividing cycle, it can deliver a large number of dough pieces, besides which, the dividing operation, performed without unduly stressing the dough, provides top quality products.

However, each dividing cycle remains dependent on the time to fill the feed chamber and, therefore, the flow time of the dough inside the hopper.

In order to reduce the filling time, the devices in the prior art provide rollers or conveyor belts to accelerate the feeding of the dough. Such devices are disclosed in documents EP 1 400 173, WO 01/05236 or US 2,642,013. Document FR 2462868 discloses a hopper according to the preamble of claim 1. Belt conveyors are rotated inside the hopper in the direction of flow of the dough at its opening at the bottom.

Such devices have many disadvantages, especially related to the complex maintenance and the problem of adhesion of the dough.

In this regard, the flow is hampered by the adhesive strength of the bakery dough along the walls of the hopper. Naturally, limiting the adhesion by applying a lubricant on these walls, in particular by spraying, has been thought of already, not to mention that these walls themselves are very often treated with a coating comprising a layer of fluorocarbon resin to reduce the adhesion.

However, the dough tends to absorb the lubricant deposited along said walls of the hopper and it is necessary to continually add more. Nevertheless, the bakery production facilities normally work continuously. Also, once loaded with dough, the inner walls of the hopper below the level of dough cannot be lubricated properly.

Moreover and as already mentioned above, insofar as the lubrication should be carried out constantly, the oil consumption is significant, creating not only an extra production cost, but also adding a fatty substance to the final product.

In particular, the addition of a fatty substance can contaminate and reduce the quality of the product obtained.

The present invention has been able to provide an answer to the above disadvantages. This is part of a first inventive step designed to assist the gravity flow of the dough, more particularly during the phase when dough is fed to the downstream processing unit of the dough.

Applied more specifically to a divider, the assistance can be conceived as occurring as filling is taking place, thus filling the feed chamber with the understanding that, once it is filled and the various dividing operations are being performed and the dough pieces are turned out, the dough can again flow freely to the bottom of the hopper until the next cycle.

In particular, the invention concerns a hopper according to claim 1.

The benefits which derive from the present invention consist in that, with the movement of the wall, the flow speed of the dough is not strictly dependent on its ability to adhere to the wall.

Furthermore, by choosing a specific distance over which the wall moves, the assistance can be provided for the dough to ensure the downstream delivery of a defined amount of dough.

Advantageously, the assistance may be for delivering and pushing a quantity of dough to the bottom of the hopper corresponding substantially to the amount of dough needed to fill the feed chamber, determined by the path of the movable wall.

In this connection, the stroke of the movable wall may be provided to be adjustable.

Moreover, once the feed chamber is filled properly and during the various dividing stages and discharge of the dough on a removal device, the movable wall(s) can be pushed back into their initial position, that is, in a direction opposite to that of the flow of the dough. In this case, the moving speed of these walls can be selected so as to draw back a minimum amount of dough in the reverse direction to its flow under gravity. Above all, the gravity flow can then take place freely and in dead time, i.e., until the feed chamber, empty from its previous load, is now available under the hopper for a new filling cycle.

Other aims and advantages of the present invention will become apparent from the following description relating to a non-limiting embodiment given for information only.

This description will be understood better by reference to the accompanying drawing in which Figures 1 to 4 illustrate diagrammatically a feed hopper according to the invention of a processing unit shown diagrammatically which volumetrically divides dough into pieces, wherein:

- Figure 1 shows diagrammatically the hopper according to the invention comprising a movable hopper wall wherein the wall is shown the open position of the hopper and is filling the feed chamber disposed below;
- Figure 2 is a representation similar to Figure 1 illustrating the position of the movable wall, after assisting the dough and the filling of the feed chamber;
- Figure 3 is a view similar to Figures 1 and 2 illustrating the position of the movable wall during the closing of the opening in the lower part of the hopper and separation of the feed chamber;
- Figure 4 is a representation similar to Figures 1 to 3 above illustrating the return of the movable wall into its initial position for assistance of the flow of the dough in the hopper.

The present invention concerns a hopper 4 comprising a device 1 designed to enhance the flow under gravity of dough 2 for bakery, pastry or similar items along a wall 3.

For a better understanding of the present invention, it has been illustrated in the drawing and described below in the form of a hopper 4 in which the dough 2 is discharged for feeding a downstream processing unit 5. The latter has been shown diagrammatically in the form of a divider to divide the dough 2 volumetrically into dough pieces.

The device 1 according to the invention is designed such that said wall 3 is movable in the direction 6 of flow of said dough 2 along the wall 3 to assist it along a defined path 7.

Advantageously, the movable wall 3 is driven by suitable motorised means (not shown) designed to provide the movement in the direction 6 to assist the dough 2, following the path 7, but in a reverse direction to return said wall to its original position. More particularly, these motorised means are designed to ensure the movement at different speeds in one direction and the other, as will be explained further in the description.

Furthermore the wall 3 is mounted to move on a fixed wall 3A.

According to a particular feature of the invention, the path 7 may be provided so that it is adjustable to push down and deliver a specified quantity of dough.

In Figures 1 to 4, the hopper 4 was shown in the form of a funnel essentially comprising two longitudinal inclined and opposing flanks 3, 8 and end walls not shown. The hopper 4 comprises, in the lower part 9, an opening 10, given that under the hopper 4, over all or part of its length, a feed chamber 11 extends for receiving a quantity of dough 2 through the flow under gravity of dough 1 from the hopper 4, said dough to be divided into dough pieces 2.

It should be noted that the opening 10 in the bottom portion 9 of the hopper 4 can be closed by means of a cutting tool 12, here shown as two blades movable in horizontal translation in opposite directions.

Referring now more particularly to Figure 1, the dough 2 can be seen stored in the hopper 4. Said dough completely fills the hopper 4 down to the lower part 9 where the opening 10 is closed by the cutting tool 12. The hopper 4 comprises a movable wall 3 seen here in a first position 13 wherein the wall 3 can subsequently cover the path 7 to assist the flow under gravity of the dough 2, after release of the opening 10 by the cutting tool 12. In the embodiment shown, the movable wall is one of the inclined sidewalls 3, 8 of the hopper 4.

This is precisely what is shown in Figure 2 where the two knives of the cutting tool 12 are drawn back laterally, given that the feed chamber 11, separate from the hopper 4, extends under the opening 10.

In the embodiment illustrated in the figures, the feed chamber 11 has a movable floor in the form of a piston 14 which, already shown in its high position in Figure 1, is now shown in Figure 2 in the lowered position defining the filling volume of the feed chamber 11.

If the filling of the latter is carried out by gravity flow of the dough 2, the flow has been assisted in the hopper 4 by the wall 3 having travelled along its path 7 in the flow direction of the dough 2 along the wall 3.

It should be noted that the path 7 of the wall 3 can be specified so as to deliver a quantity of dough determined by the assistance.

Thus, in the application shown in the figures of the attached drawing, the path 7 of the wall 3 is preferably specified to enhance the flow and delivery of a quantity of dough 2 for filling the feed chamber 11.

Now that the latter is filled completely, the opening 10 in the bottom portion 9 of the hopper 4 may be closed by the cutting tool 12, as shown in Figure 3.

The closure may be partial initially to allow a small amount of dough 2 back into the hopper 4, as the quantity of dough 2 in the feed chamber 12 is being calibrated by the piston 14.

Figure 4 illustrates the movable wall 3 in its reverse movement back to its first position 13 in which it can again assist the flow of the dough 2, in particular during a next filling cycle of the feed chamber 11.

Preferably, the ascent or the reverse stroke of the movable wall 3 is executed at a speed to overcome, if possible, the adhesive forces of the dough on the moving wall 3. At least, this speed is defined to be sufficient to overcome the shear resistance of the dough 2 so as to drag a minimum of the dough 2 in a direction opposite to that of the flow in the hopper 4.

A movable wall 3 of this type is mounted to slide by means of guides located at its ends or underneath.

Furthermore, the translation movement control can be provided by any type of suitable motorised means, in particular by means of cylinders capable of overcoming the dough's resistive forces when it is necessary to push said moveable wall 3 in its initial position beyond an assistance path for the dough.

Preferably, the movable wall 3 is superimposed on a fixed wall 3A underneath it to prevent the dough 2 from overflowing out of the container.

As part of the application to a hopper 4, the movable side wall 3 covers a fixed side 3A of the shell of the hopper 4. If at least one of the sidewalls of the shell of the hopper 4 can be covered in this way by a movable side 3, it goes without saying that it is possible to cover, with a movable wall 3, an additional wall, in particular the opposite side 8 or indeed all the walls of the hopper 4.

Moreover, in such a case, the movable walls or sidewalls 3, 8 can complete their path 7 to assist the flow of the dough 2 either synchronously or staggered in time to expedite, as appropriate, the delivery of the dough or to enhance the amount of dough delivered.

Again it should be noted that the paths 7 of the walls 3, 8 are not necessarily identical. Furthermore, separate adjustments may be provided for each one.

The benefits of the present invention are that, while guaranteeing a flow under gravity of the dough, it can be delivered rapidly by means of the hopper which contains it. Moreover, due to the assistance given to the dough, it is possible to manage the amount of dough delivered at the hopper outlet to ensure the positive, effective filling of the feed chamber 11. The result, certainly, is an increase in the rate of the dividing cycles by applying the invention to a divider.

Finally, it will be noticed that, by thus assisting the dough by the wall along which it is made to flow, the need for lubricants is reduced considerably.

The invention represents, therefore, clear technical progress in the field under consideration.

GARAT, AMELY MAGÁBAN FOGLAL EGY KÉSZÜLÉKET SÜTŐDEI TÉSZTA, SÜTEMÉNY TÉSZTA VAGY HASONLÓK ÁRAMLÁSÁNAK ELŐSEGÍTÉSÉRE EGY FAL MENTÉN

Szabadalmi igénypontok

1. Garat (4) sütődei-, sütemény-tészta vagy hasonlók eljuttatására egy áramlásirányban lefelé helyezett feldolgozó egységhez (5), amely magában foglal legalább egy készüléket (1) a nevezett tészta áramlásának elősegítésére a nevezett garat egy fala (3) mentén, ahol a nevezett fal (3) mozgatható és hajtható az áramlásnak az irányában (6) a nevezett tészta (2) gravitációs ereje által, egy kezdeti pozícióból, azon célból, hogy kíséresse az utóbbit egy meghatározott menet-távolságon (7) keresztül, ahol a nevezett fal (3) a nevezett garat egy rögzített alsó falához (3A) viszonyítva, az felett van elhelyezve, azon célból, hogy az legyen megkettőzve, **azzal jellemezve, hogy** a nevezett mozgatható fal (3) egy véges hosszúsággal rendelkezik azáltal, hogy csúszó módon van felszerelve a garatnak a nevezett rögzített falához (3A) viszonyítva a végein vagy alatta beillesztett csúszó elemeknek köszönhetően és hajtható egy ellenkező irányban a tészta áramlásához képest, oly módon, hogy az legyen visszaállítva a kezdeti pozícióba.
2. Garat az 1. igénypont szerint, **azzal jellemezve, hogy** a mozgatható fal (3) alkalmas motor eszközök által van hajtva.
3. Garat a 2. igénypont szerint, **azzal jellemezve, hogy** a nevezett motor eszközök alkalmasan vannak tervezve arra, hogy a mozgatható fal (3) legyen hajtva a tészta (2) az áramlási irányában (6) egy sebességgel, amely kisebb, mint a sebesség, amely ennek a falnak (3) a hajtására szolgál ellenkező irányban, azon célból, hogy az legyen visszaállítva a kezdeti pozíciójába.
4. Garat az előző igénypontok bármelyike szerint, **azzal jellemezve, hogy** a mozgatható falnak (3) a menet-távolsága (7) beállítható azon célból, hogy legyen eltolva és átadva egy meghatározott mennyiségű tészta.
5. Eljárás sütődei-, sütemény-tészta vagy hasonlók eljuttatására egy feltöltő kamrához (11) egy az előző igénypontok bármelyike szerinti garattól (4), ahol a nevezett tészta a nevezett garatban (4) van tartalmazva, **azzal jellemezve, hogy** az a nevezett tészta gravitációs ereje által történő áramlás elősegítéséből áll a nevezett garaton (4) belül, nevezetesen:
 - azáltal, hogy a nevezett mozgatható fal (3) hajtva van egy kezdeti pozícióból és egy menet-távolság (7) szerint egy irányban a nevezett tészta kísérése céljából, ahol a nevezett mozgatható fal (3) a nevezett garat egy rögzített alsó falához (3A) viszonyítva, az felett van elhelyezve, azon célból, hogy az legyen megkettőzve, ahol a nevezett mozgatható fal (3) egy véges hosszúsággal rendelkezik azáltal, hogy csúszó módon van felszerelve a garatnak a nevezett rögzített falához (3A) viszonyítva a végein vagy alatta beillesztett csúszó elemeknek köszönhetően;
 azután
 - azáltal, hogy a nevezett mozgatható fal (3) hajtva van egy ellenkező irányban, azon célból, hogy az legyen visszaállítva a nevezett kezdeti pozícióba.

FIG. 1

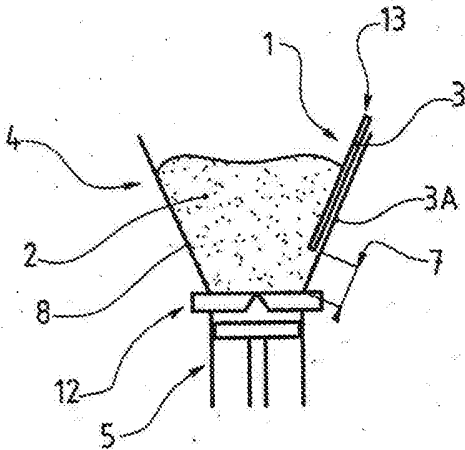

FIG. 2

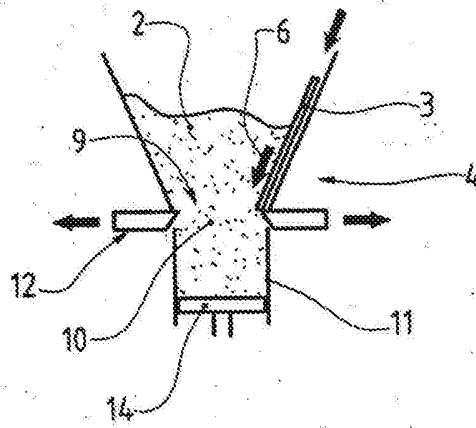

FIG. 3

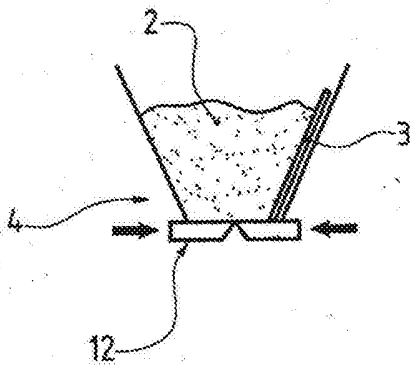

FIG. 4

