

(No Model.)

E. A. CONKLING.  
BOTTLE PACKING BOX.

No. 334,748.

Patented Jan. 26, 1886.

*Fig 1*

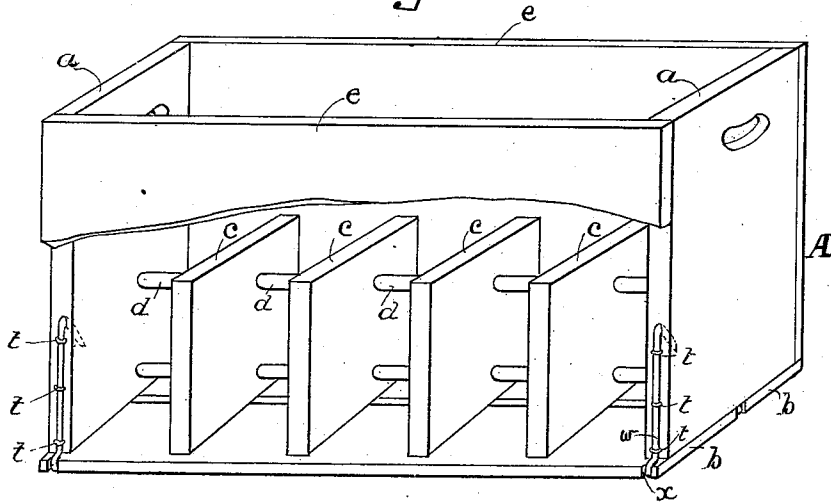

*Fig 2*

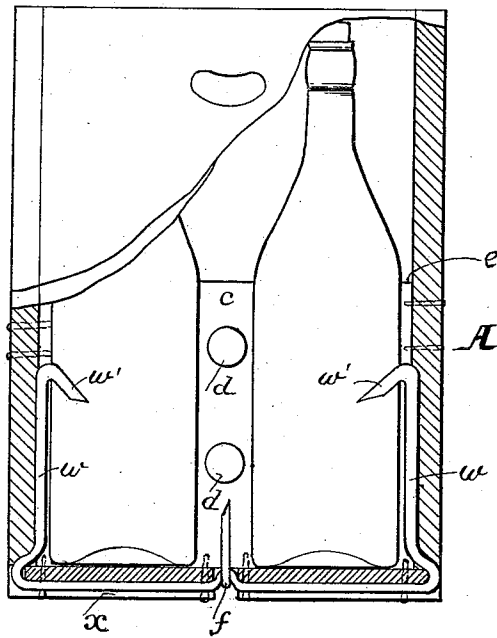

WITNESS:

*R. Gallagher*  
*Abram May*

INVENTOR

*Edward A. Conkling*

BY

*Wm. Stone*

ATTORNEY

# UNITED STATES PATENT OFFICE.

EDWARD A. CONKLING, OF MADISONVILLE, OHIO.

## BOTTLE-PACKING BOX.

SPECIFICATION forming part of Letters Patent No. 334,748, dated January 26, 1886.

Application filed January 24, 1885. Serial No. 153,909. (No model.)

To all whom it may concern:

Be it known that I, EDWARD A. CONKLING, a citizen of the United States, residing at Madisonville, Hamilton county, Ohio, have invented new and useful Improvements in Bottle-Packing Boxes, of which the following is a specification.

My invention relates to packing-boxes for bottles, its object being to produce a packing or carrying box for bottles which shall be strong, light, inexpensive, and durable as a transporting-case for delivery-wagons and other means of carriage.

To this end it consists in the construction of a box embodying a novel mode of securing the bottom by a wire independently of the usual mode of nailing, and also in the construction and arrangement of the partitions.

My invention is fully illustrated in the accompanying drawings, in which Figure 1 is a perspective elevation of the box complete, with the side partially removed; and Fig. 2, a cross-section of the box with the end partially removed.

The box to which my invention is applied is used in transporting beer-bottles and the like from the manufactory to the place of use, ordinarily in "delivery-wagons," and, as is well known, it is subjected to unusual strains of wear and tear in handling. It has been long a matter of difficulty to render them sufficiently strong without adding unduly to the weight and cost. Moreover, as they are to pack closely together in the wagon and be withdrawn singly from it, it is undesirable to have any outside braces, which might interfere with the sliding of boxes by each other, or be themselves subjected to injury. Besides, the constant dropping of bottles into place soon loosens the fastening-nails and renders further security requisite.

I construct the box A (shown in the drawings) of the ordinary rectangular form and size to hold the desired number of bottles of a given kind. The example given is designed to hold one dozen bottles of a given kind, and is furnished with stout end pieces and sides, placed together as shown. Two bottom pieces, *b b*, are used, leaving a space between for drainage, the end pieces, *a*, being first secured thereto in the ordinary manner by nails.

Across the bottom pieces, *b*, near each end,

on the under side, a narrow groove is cut to receive a cross-wire, *w*, arranged as follows: The end of the wire is bent over, as at *w'*, and driven into the exposed edge of the end piece, *a*, as shown, and is then carried downward, embedded in the wood by hammering, and secured by U-tacks *t*. Thence it is carried around the edge of or through (by gimlet-holes) the bottom piece, *b*, into the channel *x*, provided as above described, and back upon the opposite exposed edge of the end piece, *a*, as shown, where its extremity *w'* is bent and driven into the wood, as before, being similarly sunk into the edge of the end piece and secured by U-tacks. The partitions are then secured in place. These consist of a number of rectangular slabs, *c*, of the requisite size, having two or more perforations arranged in vertical planes, through which are passed wooden rods *d*, corresponding with the interior length of the box. The partitions are spaced apart as required, and the bottom pieces nailed thereto, and, if deemed necessary, one or more wires, arranged as already indicated, may be attached to support the bottom pieces from the partitions. The sides *e* are then put on and secured by nailing to the end pieces and partitions, and the bottom pieces are nailed firmly to the sides, after which a stout staple, *f*, is driven over the wire into the end piece, *a*, between the bottom pieces, *b*, carrying the wire down against the bottom of the end piece and stretching the wire and drawing the parts firmly together.

Three or more tiers of bottles may be provided for by duplicating the rod partitions.

The advantages in cheapness, strength, and durability secured by this construction are obvious. It will also be apparent that the strengthening-wires, being wholly covered and protected by the sides and passing through the sunken grooves of the bottom pieces beneath the general surface, form no obstruction to the sliding of boxes past each other in loading or unloading wagons, and the wire itself is securely protected and forms a secure fastening for the bottom against the loosening tendency of blows from bottles dropped into place and the great weight of the load of filled bottles when in place, and this is accomplished without increase of weight or cost in the box.

I claim as my invention and desire to secure by Letters Patent of the United States—

1. The combination, in a bottle-packing box, of the half-partitions *c*, extending across within the same, and secured to the sides and bottom, with the rods *d d*, passed through and held in apertures in the partitions *c* and between the ends of the box, said rods constituting practically a longitudinal vertical partition separating rows of bottles, as set forth.

2. The box *A*, provided with the retaining-wires *w*, having their ends bent and driven into the end pieces, *a*, beneath the sides *e*, and carried thence around or through the bottom

pieces, *b b*, and across in grooves *x*, constructed and arranged as set forth.

3. In a beer or wine bottle carrying box, the end pieces, *a*, side pieces, *e*, bottom pieces, *b*, retaining-wire *w*, and tightening-staple *F*, combined and arranged as and for the purpose set forth.

In testimony whereof I have hereunto set my hand in the presence of two subscribing witnesses.

EDWARD A. CONKLING.

Witnesses:

R. D. GALLAGHER,  
ABRAM MAY.