

(12) PATENT
(19) AUSTRALIAN PATENT OFFICE

(11) Application No. AU 199861003 B2
(10) Patent No. 737319

(54) Title
Method and device for inhibiting pain impulses in the nerve pathways of human beings and animals

(51)⁷ International Patent Classification(s)
A61N 001/14

(21) Application No: **199861003**

(22) Application Date: **1998.02.10**

(87) WIPO No: **WO98/42404**

(30) Priority Data

(31) Number	(32) Date	(33) Country
19712455	1997.03.25	DE

(43) Publication Date : **1998.10.20**

(43) Publication Journal Date : **1998.12.03**

(44) Accepted Journal Date : **2001.08.16**

(71) Applicant(s)
Hans Deinlein-Kalb

(72) Inventor(s)
Hans Deinlein-Kalb; Marianne Deinlein-Kalb

(74) Agent/Attorney
PHILLIPS ORMONDE and FITZPATRICK,367 Collins Street,MELBOURNE VIC 3000

(56) Related Art
US 5607453
DE 3500379



(51) Internationale Patentklassifikation ⁶ : A61N 1/14	A1	(11) Internationale Veröffentlichungsnummer: WO 98/42404 (43) Internationales Veröffentlichungsdatum: 1. Oktober 1998 (01.10.98)
---	-----------	---

(21) Internationales Aktenzeichen: PCT/EP98/00732 (22) Internationales Anmeldedatum: 10. Februar 1998 (10.02.98) (30) Prioritätsdaten: 197 12 455.0 25. März 1997 (25.03.97) DE (71)(72) Anmelder und Erfinder: DEINLEIN-KALB, Hans [DE/DE]; Georg-Stefan-Strasse 31, D-90453 Nürnberg (DE). (72) Erfinder; und (75) Erfinder/Anmelder (nur für US): DEINLEIN-KALB, Marianne [DE/DE]; Georg-Stefan-Strasse 31, D-90453 Nürnberg (DE). (74) Anwalt: BROSE, Manfred; Pellergasse 45, D-90475 Nürnberg (DE).	(81) Bestimmungsstaaten: AU, CA, CN, JP, RU, US, europäisches Patent (AT, BE, CH, DE, DK, ES, FI, FR, GB, GR, IE, IT, LU, MC, NL, PT, SE). Veröffentlicht <i>Mit internationalem Recherchenbericht.</i>
--	---

(54) Title: METHOD AND DEVICE FOR INHIBITING PAIN IMPULSES IN THE NERVE PATHWAYS OF HUMAN BEINGS AND ANIMALS

(54) Bezeichnung: VERFAHREN UND EINRICHTUNG ZUR HEMMUNG VON SCHMERZIMPULSEN IN DEN NERVENLEITUNGEN VON MENSCH UND TIER

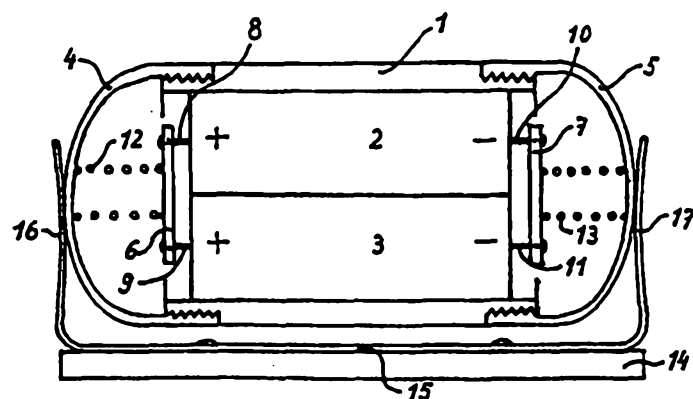

(57) Abstract

The invention relates to a method for inhibiting pain impulses in the nerve pathways of human beings and animals and to a device for implementing said method. According to the invention, the positive pole of an electrically discharged capacitor is brought into external contact with the skin surface on the pain spot of the body or on the excited nerve pathway. The pulse-like energy peaks occurring in a state of pain-induced nervous excitation and which are produced by inversion of energy in the nerve pathways, are reduced or completely eliminated by capacitor displacement flux.

Abstract

According to a method of inhibiting pain pulses in the nerves of humans and animals and a device for carrying out the method the positive pole of an electrically uncharged capacitor is contacted with the skin surface around the place of pain in the body or the excited nerve from outside or fixedly applied there. In an excitation state, caused by a state of pain, of the nerves the pulse-like voltage peaks, which arise on voltage reversal in the nerves, are reduced or completely smoothed out by the electric flux of the capacitor.



The invention relates to a method and device for inhibiting pain pulses in the nerves of humans and animals.

Pain is one of the commonest symptoms of illness or tissue damage or a metabolic disturbance. The pain is noticeable when mechanical, thermal, chemical or electrical stimuli exceed a certain threshold value.

Therapeutic analgesics which to some extent have a very strong action with just as strong side effects for humans, animals and the environment are used in combating pain.

Pain conduction in the nerve paths of humans and animals takes place by ions which migrate along to the electrically charged membrane of the nerve. A quiescent membrane is positively charged outside and negatively charged inside. The potential or voltage of the outer side relative to the inside is about 70 millivolts (mV) in the pain-free quiescent state (equilibrium rest potential). At the moment of excitation by pain, the changes reverse, whereby in the case of humans the potential decays over 1/1000 second by about 100 mV to the negative side, i.e. to a value of -30 mV from the outside to the inside. The frequency of the rising and falling phase, which occurs due to migration of ions, of the peak potential is approximately proportional to the intensity of pain to be transmitted. The speed of conduction of the nerve action can be up to 100 m/sec in the case of humans.

It would thus be desirable to provide a method and a device for the inhibiting of pain pulses in the nerves of humans and animals, which do not have the disadvantages of medicinal treatment of pain, may be completely free of side effects, may function without auxiliary energy, may be able to be made and sold economically and may not cause any environmental loading in operation and disposal of waste.

According to a first aspect of the present invention there is provided a method of inhibiting pain pulses in the nerves of humans and animals, wherein the pain pulse in a nerve consists of excitation states of the nerve cells in the form of a pulse-like current with corresponding voltage peaks, the method including the step of causing a pain pulse to be displaced in phase by displacing the pulse-like current together with its voltage peaks in phase so that the pain pulse is reduced or eliminated by the effect of the phase displacement.

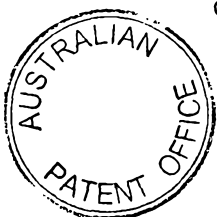

According to a second aspect of the present invention there is provided a device for carrying out the method according to the first aspect of the invention, including an electrical capacitor or a plurality of electrical capacitors connected in parallel and accommodated in a housing, the positive pole of the or each capacitor being connected with a large-area spherically rounded metal shell and the negative pole of the or each capacitor being similarly connected with an oppositely disposed, spherically rounded metal shell, the negative pole being contactable with the hand of a patient or therapist to lead the negative potential to ground.

Preferably, the capacitor or several capacitors in parallel connection are accommodated in a closed housing, the positive pole of the or each capacitor is connected with a large-area spherically rounded metal shell and the negative pole of the or each capacitor similarly with an oppositely disposed, spherically rounded metal shell, and the negative potential is led to ground by way of the hand of the patient or the therapist.

For preference, the capacitance of the capacitor or the total capacitance of the capacitors connected in parallel is at least 10,000 microfarads (μF).

In one preferred example of the method, one or more capacitors is or are mounted in fixed location in furniture for sitting or lying on or in the bed of the patient and the positive pole or poles thereof comes or come to constantly bear against contact with the places of pain in the patient and the negative pole or poles is or are applied to ground.

In another preferred example of the method, one or more capacitors in special flat mode of construction is or are held by means of a bandage at the pain-conducting parts of the body or held in the clothing of the patient against the pain-conducting parts of the body, wherein the positive pole of the or each capacitor is directed to the place of pain and the negative pole is drained off to a remote part of the body.

An example of the method and embodiment of the device of the present invention will now be more particularly described with reference to the accompanying drawing, the single figure of which is a schematic view of a device, embodying the invention, for manual use.



The device shown in the drawing consists of a tubular housing 1, electric capacitors 2 and 3, metal shells 4 and 5, contact plates 6 and 7, conductor wires 8, 9, 10 and 11 and compression springs 12 and 13, and the device is shown retained in a spring holder 14 with spring clips 16 and 17 and a connecting web 15.

Installed in the tubular housing 1, which consists of a non-conductive material, are, for example, two rod capacitors 2 and 3 which are parallel to the centre axis of the tubular housing 1 and from the cylindrical ends of which project the conductor wires 8, 9, 10 and 11. The respective like-poled ends of the conductor wires 8, 9 and 10, 11 are soldered to contact plates 6 and 7, so that a parallel connection of the capacitors 2 and 3 results. Screwed into the respective tube openings of the tubular housing 1 at both ends are metal shells 4 and 5, which produce a constant contact between the metal shells 4 and 5 and the capacitors 2 and 3 by way of the compression springs 12 and 13, the contact plates 6 and 7 and the conductor wires 8, 9, 10 and 11. The number of capacitors depends on the constructional design of the subject of the invention and on the size of the desired capacitor capacitance.

In readiness setting, i.e. when the device is not in use, this is retained in the spring holder 14 in such a manner that the housing 1 is clamped between two conductive spring clips 16 and 17, whereby a throughflow connection between the metal shell 4 and the metal shell 5 is produced at the same time by way of the spring clip 16, the connecting web 15 and the spring clip 17. It is ensured by this short-circuit of the capacitors 2 and 3 that the device always comes into use free of potential or charge when this is removed from the spring clip.

In use of the device against an attack of pain, the tubular housing 1 is unclipped by the fingers in such a manner that the metal shell 5 (negative pole side) comes to lie against the hollow inner hand. The oppositely disposed end with the metal shell 4 (positive pole side) is pressed with light pressure against the place of pain in the body. A conductive connection is thereby produced between the nerve, which is conducting the pain signal, and the positive pole side of the capacitors 2 and 3 via the tissue and skin surface. The pulse-like voltage peaks, which occur on voltage inversion, in the nerve are thus reduced by the electric flux with the capacitors 2 and 3 or completely smoothed out. The nerve concerned thus signals freedom of pain to the brain.



Tests have shown that, for example in the case of strong back, muscle, joint and sciatica pains and in the case of painful calf cramps the intensity of pain was reduced abruptly or in switchlike manner to zero after about four (4) minutes through use of the device. This means that the stronger the pain and thus analogously the voltage and pulse frequency in the nerve, the greater and more effective the compensation by the capacitors 2 and 3.

The use must be prolonged somewhat more, perhaps ten (10) minutes, if the nerve of a more deeply seated organ is to be treated, because possible air voids or bone parts attenuate the electric flux to the capacitors 2 and 3.

The time for the ensuing freedom of pain subjectively assessed by the patient after a treatment was reported at about two (2) hours to several days, wherein compensation for strong pains lasts rather longer in terms of time than for less-strong pains.

It is self-evident that voltage peaks in the thus-called motor nerves, for example in the case of a tremor attack, can also be reduced or smoothed out by the subject of the invention.

It has also been found that a short-circuit bridge between the positive and negative poles of the capacitors 2 and 3 increases the dynamic capacity of the capacitors 2 and 3. This has the advantage that the capacitors 2 and 3 in the static state are no longer permanently chargeable and thus undesired discharging currents and discharging voltages are at the same time made impossible.

The dynamic pulse-like electric flux around the static zero potential of the capacitors 2 and 3 relative to the nerve is thereby improved in the range of about 3 to 500 Hertz. The spring holder 15, 16, 17 for the discharging of the capacitors over time can be omitted.

If the place of pain or the pain-transmitting nerve cannot be clearly localised, it is then advantageous to cover the place of pain at the skin surface with a metal foil, for example an aluminium foil, to wrap extremities, for example an arm or a leg, with the metal foil, and to connect the foil directly or by means of cable with the short-circuited capacitors 2 and 3. this procedure is also indicated for headaches of unknown genesis.



A further very effective method of treatment of pain is also achieved by a direct or indirect contact of the subject of the invention with large volume arteries. If, for example, the contact pole of the subject of the invention is brought to bear against the skin surface directly at the carotid artery (Carotis), then a conductive connection between the short-circuited capacitors 2 and 3 in the subject of the invention and the conductive pulsating blood in the artery is thereby produced and thus at the same time an electric flux between nerves, which are excited in pain, everywhere in the body of the patient and the subject of the invention. Both carotid arteries can also be brought into contacting connection at the same time with the device by an external bridge, for example by means of a metal foil or a conductive metal neck band.

This process is thus to be understood in the sense that the capacitive field of the capacitors 2 and 3 in the subject of the invention is also extended to the entire volume of blood of the patient. Thus, apart from blocking pain, the electric potential enhanced in the vegetative nervous system by the pick up of so-called "electro-smog" from the environment or by change in weather can be reduced and thus a better well-being is imparted to the patient.

It is obvious that the device can also be implanted, for example in miniature mode of construction, as a permanent unit below the skin surface in direct or indirect contact with an artery.

It is also possible that the person or animal is disposed in a water bed, which in turn is connected with short-circuited capacitors of increased capacity, for the purpose of pain therapy.

The device has meanwhile been successfully proven many times, wherein the use success rate in the case of intact, undamaged nerves lies at almost 100%.

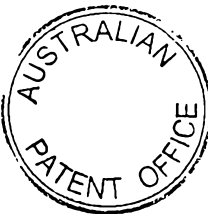
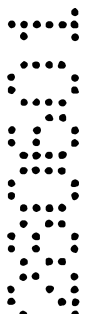
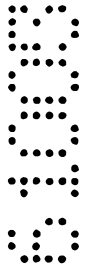

The claims defining the invention are as follows:

1. A method of inhibiting pain pulses in the nerves of humans and animals, wherein the pain pulse in a nerve consists of excitation states of the nerve cells in the form of a pulse-like current with corresponding voltage peaks, the method including the step of causing a pain pulse to be displaced in phase by displacing the pulse-like current together with its voltage peaks in phase so that the pain pulse is reduced or eliminated by the effect of the phase displacement.

2. A method according to claim 1, wherein the step of causing the phase displacement comprises the step of bringing a pole of an uncharged electrical capacitor into contact with the skin surface over a place of pain or an excited nerve so that the voltage peaks of the pain pulse are reduced or completely smoothed out through the capacitance current of the capacitor.

3. A method according to claim 1, wherein the step of causing the phase displacement comprises the step of mounting an uncharged electrical capacitor or a plurality of uncharged electrical capacitors connected in parallel in fixed location in furniture for sitting or lying on or in the bed of a patient so that the positive pole or poles of the capacitor or capacitors comes or come to constantly bear against the places of pain in the patient and the negative pole or poles is or are applied to ground.

4. A method according to claim 1, wherein the step of causing the phase displacement comprises the step of fixing an uncharged electrical capacitor or a plurality of uncharged electrical capacitors connected in parallel by means of a bandage or clothing against the pain-conducting parts of the body of a patient so that the positive pole or poles of the capacitor or capacitors is or are directed to the place of pain and the negative pole or poles is or are drained off to remote parts of the body.

5. A method according to claim 1, wherein the step of causing the phase displacement comprises the step of covering large-area, deeper-seated places of pain in a patient at the surface of the skin over the place of pain by means of a conductive metal foil contacting the skin surface all round and connecting the foil directly or by way of a cable with an uncharged electrical capacitor or a plurality of uncharged electrical capacitors connected in parallel.



6. A method according to claim 1, wherein the step of causing the phase displacement comprises the step of bringing an uncharged electrical capacitor or a plurality of uncharged electrical capacitors connected in parallel into conductive connection with a large-volume artery of a patient directly or indirectly via the surface of the skin or as an implant.

7. A method according to claim 1, wherein the step of causing the phase displacement comprises the step of disposing a person or animal in a water bed and connecting the bed with an uncharged electrical capacitor or a plurality of uncharged electrical capacitors connected in parallel.

8. A method according to any one of claims 2 to 7, wherein the capacitance of the capacitor or the total capacitance of the capacitors is at least 10,000 microfarads.

9. A device for carrying out the method according to any one of the preceding claims, including an electrical capacitor or a plurality of electrical capacitors connected in parallel and accommodated in a housing, the positive pole of the or each capacitor being connected with a large-area spherically rounded metal shell and the negative pole of the or each capacitor being similarly connected with an oppositely disposed, spherically rounded metal shell, the negative pole being contactable with the hand of a patient or therapist to lead the negative potential to ground.

10. A device according to claim 9, wherein the positive and negative poles of the capacitor or each of the capacitors are permanently connected together by means of a short-circuit bridge to form a resonant circuit.

Dated: 26 June 2001

PHILLIPS ORMONDE & FITZPATRICK

Attorneys for:

HANS DEINLEIN-KALB

