



(51) International Patent Classification:

G01J 3/457 (2006.01) G02B 6/10 (2006.01)  
G01J 3/28 (2006.01) G02B 6/52 (2006.01)

(21) International Application Number:

PCT/US2018/037590

(22) International Filing Date:

14 June 2018 (14.06.2018)

(25) Filing Language:

English

(26) Publication Language:

English

(72) Inventor; and

(71) Applicant: JINGHONG, Chen [US/US]; 467 Maple Ave.,  
Milpitas, CA 95035 (US).

(81) Designated States (unless otherwise indicated, for every kind of national protection available): AE, AG, AL, AM, AO, AT, AU, AZ, BA, BB, BG, BH, BN, BR, BW, BY, BZ, CA, CH, CL, CN, CO, CR, CU, CZ, DE, DJ, DK, DM, DO, DZ, EC, EE, EG, ES, FI, GB, GD, GE, GH, GM, GT, HN, HR, HU, ID, IL, IN, IR, IS, JO, JP, KE, KG, KH, KN, KP, KR, KW, KZ, LA, LC, LK, LR, LS, LU, LY, MA, MD, ME, MG, MK, MN, MW, MX, MY, MZ, NA, NG, NI, NO, NZ,

OM, PA, PE, PG, PH, PL, PT, QA, RO, RS, RU, RW, SA, SC, SD, SE, SG, SK, SL, SM, ST, SV, SY, TH, TJ, TM, TN, TR, TT, TZ, UA, UG, US, UZ, VC, VN, ZA, ZM, ZW.

(84) Designated States (unless otherwise indicated, for every kind of regional protection available):

ARIPO (BW, GH, GM, KE, LR, LS, MW, MZ, NA, RW, SD, SL, ST, SZ, TZ, UG, ZM, ZW), Eurasian (AM, AZ, BY, KG, KZ, RU, TJ, TM), European (AL, AT, BE, BG, CH, CY, CZ, DE, DK, EE, ES, FI, FR, GB, GR, HR, HU, IE, IS, IT, LT, LU, LV, MC, MK, MT, NL, NO, PL, PT, RO, RS, SE, SI, SK, SM, TR), OAPI (BF, BJ, CF, CG, CI, CM, GA, GN, GQ, GW, KM, ML, MR, NE, SN, TD, TG).

Published:

— with international search report (Art. 21(3))

(54) Title: HIGH SENSITIVITY OPTICAL DETECTION SYSTEM

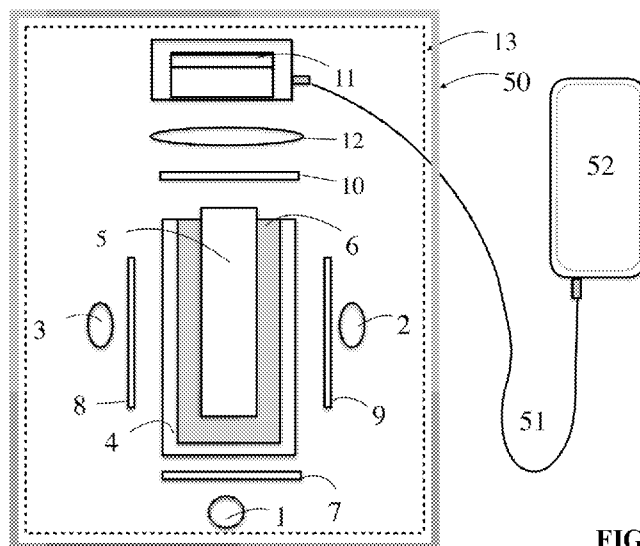

FIG. 2

(57) Abstract: A high sensitivity optical system for detection of chemical and biological analytes is disclosed comprising a vessel, a light-guide, analytes, excitation light source(s), a detector, excitation and emission filter(s), and light directing components. The novel optical system is secured in housing and connected to devices extrinsically or intrinsically for data input, process, display, storage, and communication. This optical system could enable clinical level diagnosis of a wide range of diseases in an inexpensive mobile point-of-care format. It can be a stand alone unit with single or an array of optical structures, or used in combination with other detection systems such as mobile microscope to form a qualitative and quantitative detection apparatus. It can also be implemented in some commercial instruments to improve sensitivities. Furthermore, the form factor of the optical system can be significantly reduced to form a highly integrated lab-on-a-chip solution.



## HIGH SENSITIVITY OPTICAL DETECTION SYSTEM

### FIELD OF THE DISCLOSURE

[0001] The present application relates to optical systems for detection of chemicals and biological analytes, and more specifically to mobile optical detection systems for point-of-care (POC) applications that deliver high sensitivity from small volumes and very low concentration samples yet using small and low cost optical components.

### BACKGROUND

[0002] Point of care (POC) testing has steadily increased in recent years largely driven by delivering less costly preventative care closer to the patient's home in the developed world and more effective care for infectious diseases in the developing world. However, until today the dominant success has been the glucose biosensor, lateral flow strips as cardiac markers, and pregnancy test.

[0003] Wide spread of POC technologies is limited by the testing ability from small handheld devices and the high cost of bench-top devices which are essentially laboratory instruments reduced in size and complexity. The key to broader POC adoption remains to be how to transfer the sophisticated disease testing capability and sensitivity of microscopy and spectroscopy from the laboratory to small mobile devices with low cost components and without the associated inferior performance. The ever increasing use of mobile phones worldwide and rapid rate of mobile technology development have raised the hope and triggered unprecedented research of mobile devices to be utilized for medical diagnostics in recent years. POC devices can reduce cost by taking advantage of the extrinsic and intrinsic sensors, and ubiquitous accessibility of communication, computation, display, and data storage. However, the various intrinsic sensors selected solely for mass consumer applications are yet to find commercial success in providing enhancement of detection sensitivity.

[0004] Fluorescent labeling is widely used for biochemical analysis and disease diagnosis. The standard devices for fluorescent detection are fluorometer, fluorescence spectroscopy, and enzyme-linked immunosorbent assay (ELISA) plate-reader used in high through-put bioassays to detect the presence of a substance. In the above mentioned instrumentations, both fluorescence excitation and emission are

greatly attenuated in the liquid solution before reaching to the detector. As a result, the light collection efficiency is low, often requiring high power and expensive photomultiplier tube (PMT) to amplify the weak signals.

[0005] Various approaches have been investigated to increase the sensitivity, including multiplication of the diagnostic targets such as culture or polymerase chain reaction (PCR), use of high selectivity and high intensity molecular labeling probe, use of high sensitivity optical detection systems, etc.. This invention focus on improving sensitivity of optical detection systems.

### SUMMARY

[0006] The present invention provides design principles of a high sensitivity optical detection system that include a vessel, a light-guide inside, excitation light source(s) at the proximal end of the vessel, and/or perpendicular excitation light source(s) on the side of the vessel, a detector at the distal end of the vessel, excitation and emission filter(s), and other optical components to direct light. The optical system can be used to detect emissive or absorptive materials in the volume between the vessel and the light-guide, and/or on their surfaces. This optical system can achieve large signal and signal to noise (S/N) ratio for quantitative analysis even with low cost and small form factors components. The high sensitivity comes from the effective light excitation of the materials, the highly efficient emission guided to the detector by light-guide and/or vessel side wall, and noise isolation between light source(s) and detector(s). This novel optical system and its variants enable clinical level diagnosis in an inexpensive mobile point of care (POC) format which could be a key to trigger broader POC adoption for wide range of disease detections.

[0007] In the preferred embodiment, the optical system has an end LED and two side LEDs, a glass light-guide and vessel, a fluorescence analyte solution, a pair of filters, a photodiode detector, and lens in the emission and detection optical paths. The optical system is hosted in opaque mechanical structure(s) which eliminate noise from the ambient light, prevent light leakage from the excitation light source(s), and only allow light through the designated optical path. It is linked externally with phone, tablet, or computer etc for data input, process, display, storage, and communication. The optical system can generate a detection signal and sensitivity similar to commercial fluorometer and enzyme-linked immunosorbent assay (ELISA) plate reader.

[0008] In one embodiment, instead of being a stand alone unit with single or an array of the above optical structures, the optical system can also be combined with other detection systems such as a mobile microscope to form a qualitative and quantitative detection apparatus.

[0009] Another embodiment and its variants, for example, may be implemented in the existing analytical instrumentations such as ELISA plate reader. A fixture attached with repeating light-guides can be placed inside the wells of ELISA plate to achieve higher sensitivity.

[0010] Another embodiment and its variants, for example, can be incorporated in existing micro-fluidic devices such as GenXpert to further improve the detection sensitivity by insertion of excitation light-guides and/or emission light-guides.

[0011] Another embodiment and its variants, for example, can be used as a lab-on-a-chip solution, which is composed of highly integrated light source(s), micro-fluidic chambers, analytes, light detectors, waveguide structures, filters, patterned lens and other micro optical components. When associated optical components are tunable in a wide range of spectrum, the device can function as various spectroscopies such as fluorescence, UV-Vis, and IR spectroscopy, etc..

[0012] While multiple embodiments are disclosed, still other embodiments of the present invention will become apparent to those skilled in the art from the following Detailed Description. As will be realized, the embodiments are capable of modifications in various aspects, all without departing from the spirit and scope of the embodiments. Accordingly, the drawings and detailed description are to be regarded as illustrative in nature and not restrictive.

#### BRIEF DESCRIPTION OF THE DRAWINGS

[0013] The present invention is further detailed with respect to the following drawings. These figures are not intended to limit the scope of the present invention but rather illustrate certain attributes thereof.

[0014] FIG. 1 illustrates a 2D view of an exemplary high sensitivity optical detection system and associated optical components according to the preferred embodiment.

[0015] FIG. 2 is a 2D view of an exemplary high sensitivity optical detection system in mechanical enclosure and connected to mobile phone according to the preferred embodiment.

[0016] FIG. 3 is a 2D view of an exemplary mobile apparatus with the optical system in FIG. 1 and microscope attached to phone camera.

[0017] FIG. 4 is a 2D view of an exemplary ELISA plate with light-guide and side light sources for better signal sensitivity.

[0018] FIG. 5 is a 2D view of an exemplary fixture with light-guide(s) and end features to attach to ELISA plate.

[0019] FIG. 6 is a 2D view of a modification to micro fluidic chip in GenXpert, adding emission light-guides in the fluidic chamber to improve detection sensitivity.

[0020] FIG. 7 is a 2D view of the cross section of the emission light-guides inside GenXpert micro fluidic chamber in FIG. 6. The bottom of the light-guide attachment to the bottom wall of the micro fluidic chamber could be continuous, or with small posts to reduce optical leakage through the wall.

[0021] FIG. 8 is a 2D view of another modification to GenXpert micro fluidic chip, adding excitation and emission light-guides in the fluidic chamber to further improve detection sensitivity.

[0022] FIG. 9 illustrates a 2D view of an exemplary lab-on-a-chip solution, which is composed of integrated light source, micro-fluidic chambers, analytes, light detector, waveguide structures, filters, patterned lens and other micro optical components.

#### DETAILED DESCRIPTION

[0023] In the following description of examples, reference is made to the accompanying drawings which form a part hereof, and in which it is shown by way of illustrating specific examples that can be practiced. It is to be understood that other examples can be used and structural changes can be made without departing from the scope of the disclosed examples.

[0024] The present invention provides a low cost mobile apparatus for high sensitivity optical detection of chemical and biological analytes, more specifically a POC device for wide range of disease diagnosis. The novel optical device configuration is designed to maximize the excitation, efficiently collect and guide the fluorescence signal to a detector, and isolate noise of the light source from the detector.

[0025] FIG. 1 shows a 2D view of the high sensitivity optical detection system 13. This system 13 includes a vessel 4, a light-guide 5 inside, excitation light source 1 at the proximal end of the vessel, and/or excitation light source 2-3 on the side of the vessel, a photodetector 11 at the distal end of the vessel, excitation filters 7-9 and emission filter 10 after excitation light source(s) 1-3 and before photodetector 11 respectively. The optical system 13 is used to detect analyte 6 in liquid phase or solid

phase format in the volume between the vessel **4** and the light-guide **5** and/or on their surfaces. Lens **12** and/or other optical components are optional between light source(s) **1-3** and vessel **4**, and/or between light-guide **5**/vessel **4** and photodetector **11** if needed. This optical system **13** can achieve large signal and high sensitivity for quantitative analysis even with low cost LED light source(s) **1-3** and silicon photo detector **11**.

[0026] The light source **1-3** can be Mercury or Xenon arc lamps, laser, light emitting diode (LED), and organic light emitting diode (OLED); there can be one or more end light source **1** and side light source **2-3**, the end and side light source could be used alone or in various of combinations. Vessel **4** and light-guide **5** can be made of materials such as glass, quartz, other inorganic materials, polymeric materials, or metal; Vessel **4** and light-guide **5** can be transparent, or partially opaque, or partially covered by opaque materials; Vessel **4** and light-guide **5** can be cylindrical, a rectangular or other shapes; light-guide **5** can be solid or hollow, or other structures; the height of the light-guide **5** can be the same as the vessel **4** wall or different. Filters **7-10** can be absorption filters, interference filters, and diffraction filters. Detector **11** can be photodiode, CMOS, CCD, or PMT. Lens **12** could be a single lens or a compound lens made of glass or polymeric materials. Analyte **6** can be solution or dispersion of biological species such as sputum, urine, blood etc. which can be treated or as is. Analyte **6** can be self absorptive or emissive, or tagged with absorptive or emissive materials.

[0027] FIG. 2 illustrates an optical apparatus with element **13** hosted in a small opaque mobile enclosure **50** that would allow ease of insertion and removal of the test vessel **4** and the light-guide **5**. The mobile enclosure **50** eliminates noise from the ambient light and block light leakage from the excitation light source(s), only allows light through the designated optical path and in selected areas.

[0028] FIG. 2 also shown that the above optical apparatus can be linked externally via connector **51** with mobile phone, tablet, or computer **52** etc. for data input, process, display, storage, and communication. The optical system **13** can also be used as an attachment to the intrinsic sensors of mobile device such as camera, ambient light sensor (ALS), proximity sensor. In this case, the photodetector **11** is replaced by camera CMOS, ambient light sensor (ALS), proximity sensor. The high sensitive optical detection system **13** narrows the gap between the sophisticated disease testing capability and sensitivity of spectroscopy in the laboratory and small mobile devices with low cost components, could be a key to trigger broader POC adoption for many disease detection, including

massive epidemics such as HIV, Tuberculosis, etc., chronic illness of diabetes, heart and vascular risks, hormone imbalance, and many more. It can also be utilized for food safety inspection.

[0029] The optical **13** and its variants can be used in combination with other detection systems such as a mobile microscope to form a mobile diagnosis apparatus, which is preferably used in certain setting if an optical image is also desirable. FIG. **3** shows a 2D view of a mobile apparatus with the optical system **13** in FIG. **1** and microscope **16** attached to the camera **15** of the mobile phone **14**. Light source **17** is placed in a small enclosure **21**. An excitation filter **18** is placed on top of the enclosure **21**, above which is the test sample **19**. An emission filter **20** is attached to the end of the microscope **16**. The entire setup can be placed in a mechanical housing **53** to eliminate noise from the ambient.

[0030] The optical system **13** and its variants can also be implemented as a component in the existing apparatus such as ELISA plate reader. FIG. **4** shows a 2D view of the ELISA plate **24** with light-guide **25** and side light sources **27** and **29** for better signal sensitivity. Light source **22** and filter **23** represent the original light source and filter in ELISA plate reader. Light source **27**, **29** and filter **28**, **30** represent the additional light sources and filters for improved detection sensitivity. **26** is the analyte in the form of solution or dispersion of biological species such as sputum, urine, blood etc. which can be treated or as is. FIG. **5** shows a 2D view of an exemplary fixture **31** with light-guide **25** and end features **32-33** to attach to ELISA plate(s) **24**. A fixture **31** molded with repeated light-guides **25** can be placed inside current ELISA plate (s) **24** to achieve higher sensitivity. Features **32-33** at the two end of the fixture **31** are used to control the insert depth of the light-guides **25** and secure fixture **31** on ELISA plate (s) **24**. The ELISA surface treatment can be either on the micro-plate or on the wave-guiding fixture or on both. If the ELISA surface treatment is on the micro-plate, the wave-guiding fixture could be reusable.

[0031] The optical system **13** and its variants can also be implemented in micro fluidic chip design to further improve the detection sensitivity. FIG. **6** shows a 2D top view of GenXpert micro fluidic chip **39** of on the side of the cartridge **38**. **46** and **47** represent microfluidic inlet and outlet respectively. **48** is the fluidic chamber where PCR amplified materials are being excited and their fluorescence is detected from the side at 90 degree angle. **36** are the excitation light sources in light box **34**, and **37** are the emission light detectors in detector box **35**. **41-44** are the excitation light path. Emission light-guides **40** are added to the fluidic chamber **48** to improve detection sensitivity.

[0032] FIG. **7** shows a 2D view of the cross section of the emission light guides **40** inside GenXpert micro fluidic chamber **48** along the cross section line **45** in FIG. **6**. The bottom of the light-guide

attachment **40** to the bottom wall of the micro fluidic chamber **48** could be continuous or use two or more small posts to reduce optical leakage through the wall.

[0033] In another configuration, FIG. **8** shows a 2D view of GenXpert micro fluidic chip **39** of on the side of the cartridge **38**. All are the same as FIG. **6** except excitation light-guides **49** are added to the fluidic chamber to further improve detection sensitivity.

[0034] FIG. 9 illustrates a 2D view of an exemplary lab-on-a-chip solution, which is composed of integrated light source, micro-fluidic chambers, analytes, light detector, waveguide structures, filters, patterned lens and other micro optical components. The optical system of the lab-on-a-chip solution could be in single or array format. When associated optical components are tunable in a wide range of spectrum, the device can function as various spectroscopies such as fluorescence, UV-Vis, and IR spectroscopy, etc. As the degree of integration increases and the size of each components shrinks, less amount of analyte samples is required for each test.

[0035] The foregoing description is illustrative of particular embodiments of the invention, but is not meant to be a limitation upon the practice thereof. The following claims, including all equivalents thereof, are intended to define the scope of the invention.

What is claimed is:

1. An optical system for detection of chemical and biological analytes comprising a vessel, a light-guide separated from the vessel, excitation light source(s) at the proximal end of the vessel, and/or on the side of the vessel, a detector at the distal end of the vessel, excitation and emission filter(s), lens and other optical components along the excitation and emission optical path.
2. The optical system of claim 1, wherein the said light source can be Mercury or Xenon arc lamps, laser, LED, and OLED etc. in single or a plurality format.
3. The optical system of claim 1, wherein the said light-guide and vessel:  
can be made of glass, quartz, other inorganic materials, polymeric materials, metals, or a combination of them; and  
can be transparent, or partially opaque, or partially covered by opaque materials; and  
can be cylindrical, a rectangular, or other shapes; and  
can be solid, or hollow, or other structures in full or partial.
4. The optical system of claim 1, wherein the said analytes:  
can be absorptive or emissive materials between the vessel and the light-guide, and/or on their surfaces; and  
can be self absorptive or emissive, or tagged with absorptive or emissive materials.
5. The optical system of claim 1, wherein the said filter:  
can be absorption filters, interference filters, or diffraction filters, or a combination of them; and  
can be single, array or in a plurality format.
6. The optical system of claim 1, wherein the said detector can be photodiode(s), CMOS, CCD, PMT, etc..
7. The optical system of claim 1, wherein the said optical system can be composed of discrete, partially integrated, or highly integrated optical components in single, array, or in plurality format.
8. The optical system of claim 1, wherein the said optical system:  
can be connected extrinsically via a connector or wireless communication to a device, such as (mobile) phone, tablet, computer etc. for data input, process, display, storage, and communication; or  
can be attached to the intrinsic sensors of a device, such as (mobile) phone camera, ambient light sensor (ALS), proximity sensor, etc..

9. The optical system of claim **8**, wherein the said optical system can serve as an essential low-cost, mobile point-of-care device for quantitative detection of very low concentration of chemicals and biological analytes, or can be used in combination with other detection systems such as a mobile microscope to form a detection apparatus if rapid visual imaging and quantitative measurement of an analyte concentration are both desirable.

10. The optical system of claim **9**, wherein the said mobile microscope could be a stand alone unit connected to a common structure of the said apparatus, or attached to the intrinsic sensors of a device, such as mobile phone camera, etc..

11. The optical system of claim **9**, wherein the said detection apparatus can be secured in mechanical housing, isolated from ambient noise and protected from mechanical impact.

12. The optical system of claim **1**, wherein the said optical system can be implemented in existing instrumentations such as ELISA plate-reader by adding plurality of light-guide(s) to a multi-well plate to further improve detection sensitivity.

13. The optical system of claim **1**, wherein the said optical system can be implemented in micro fluidic based instrumentations such as GenXpert by adding excitation and/or emission light-guide(s) in the fluidic chamber to further improve detection sensitivity.

14. The optical system of claim **1**, wherein the said optical system can be a lab-on-a-chip solution: comprising light source(s), micro-fluidic chamber(s), analytes, light detector(s), waveguide structure(s), filters, (patterned) lens, and other (micro) optical components; and can be in discrete, partially integrated, and highly integrated format; and can be single, array or in a plurality format; and can function as various spectroscopies such as fluorescence, UV-Vis, and IR spectroscopy, etc. with the associated optical components tunable in a wide range of spectrum. can be assembled on substrate of silicon, glass, ceramics, metals, polymers, etc..

15. An apparatus for detection of chemical and biological analytes comprising: an optical system composed of light source(s), a vessel, a light-guide, analytes, filter(s), a detector, and light directing components; and a housing to which the optical system is secured; and a device with data input, process, display, storage, communication capability.

16. The apparatus of claim **15**, wherein the said housing:

can be made of metals, alloys, ceramics, polymeric materials, a combination of them, etc.; and  
can be rigid, semi-rigid, or flexible depending on application need; and  
can be structured to block the noise of excitation light source(s) from reaching the detector, to  
control the location and exposure areas of the light source(s), and to allow ease of insertion and  
removal of the test vessel and the light-guide.

can be opaque such that the said optical system is isolated from ambient noise; and  
can be semi-transparent or transparent, particularly in the lab-on-a-chip solution where the said  
optical system can be covered with opaque coating(s) in entirety.

17. The apparatus of claim **15**, wherein the said device:

can be mobile or stationary phone, tablet, computer, and other readily available devices; and  
can be linked extrinsically via a connector or wireless communication to the said optical system; or  
can be attached directly to the said optical system via its intrinsic sensors, such as camera,  
video camera, ambient light sensor (ALS), proximity sensor, etc..

18. The apparatus of claim **15**, wherein the said apparatus can be single, array or in a plurality  
format.

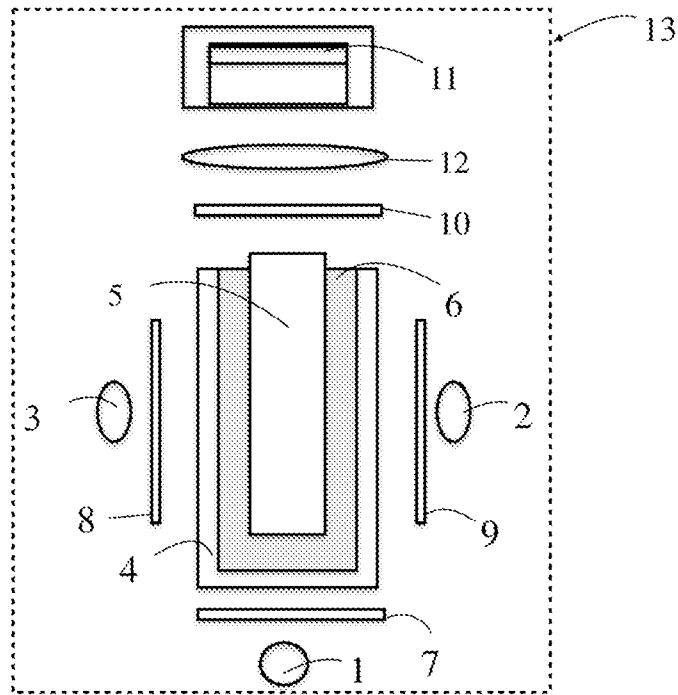

FIG. 1

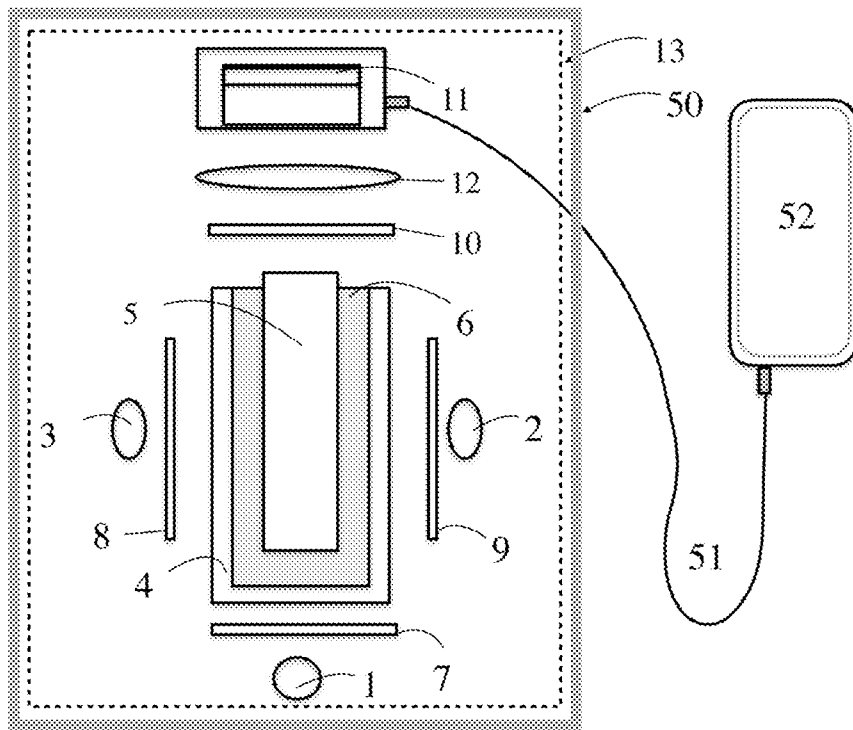

FIG. 2

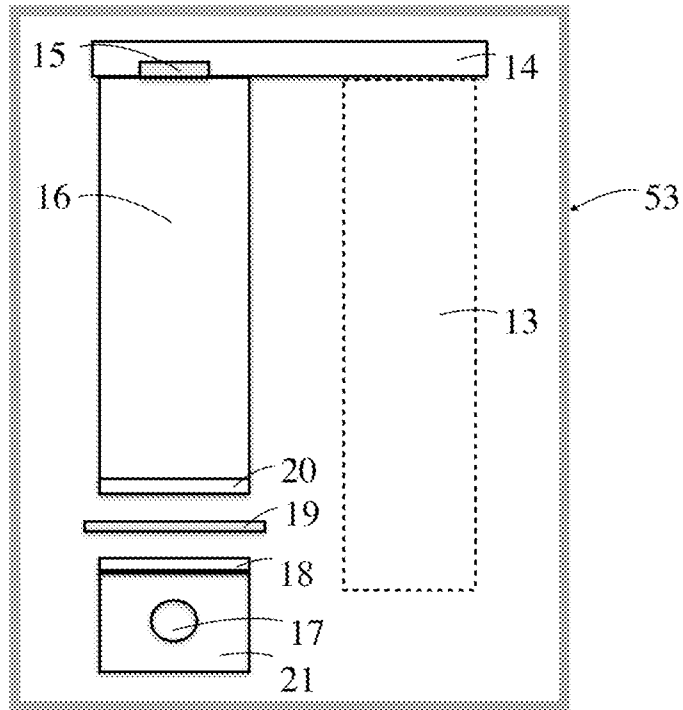

FIG. 3

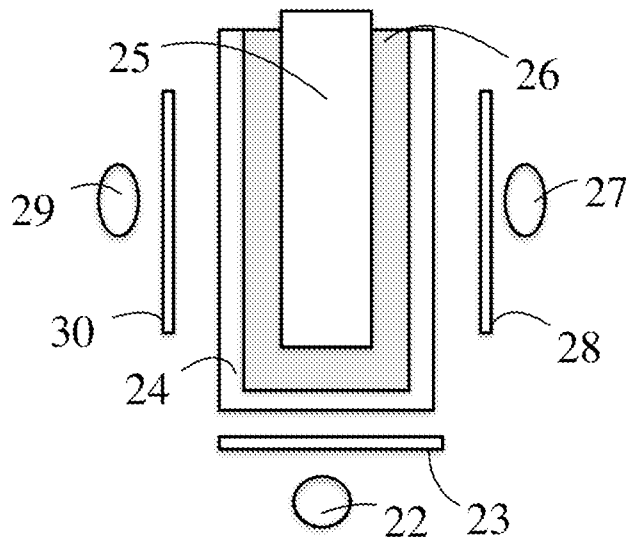

FIG. 4

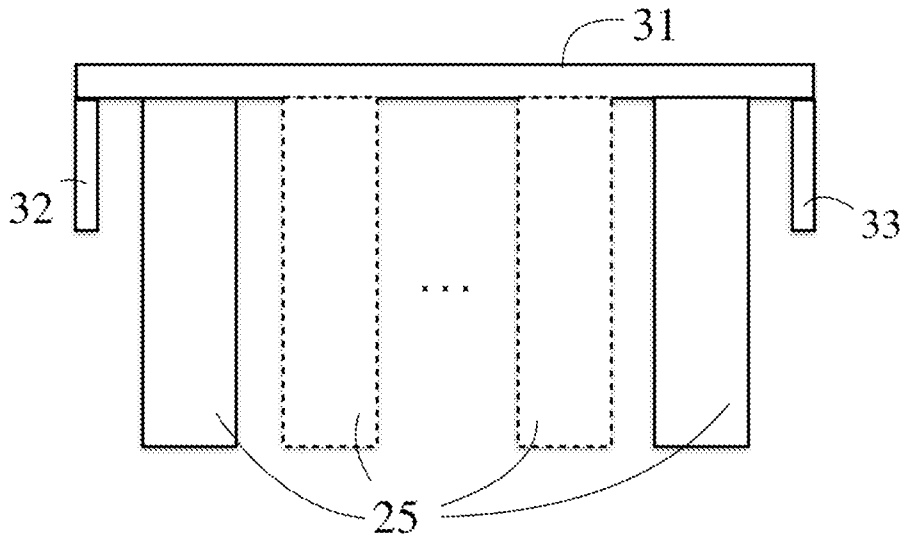

FIG. 5

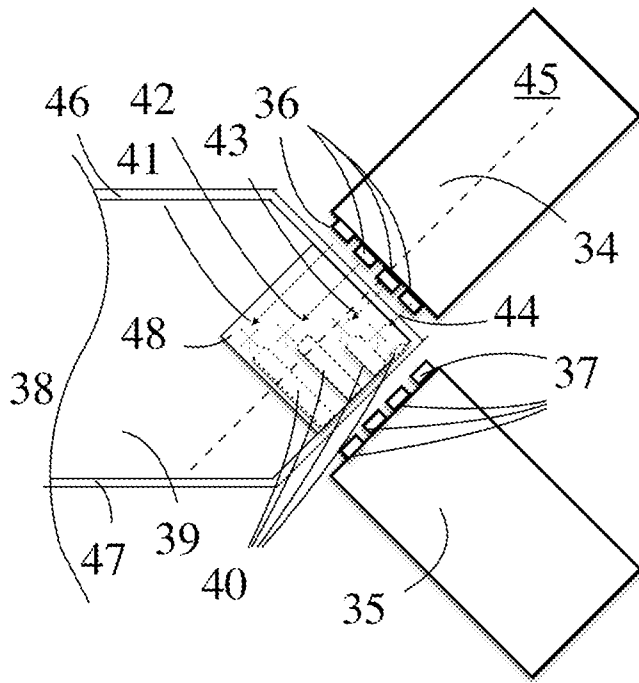

FIG. 6

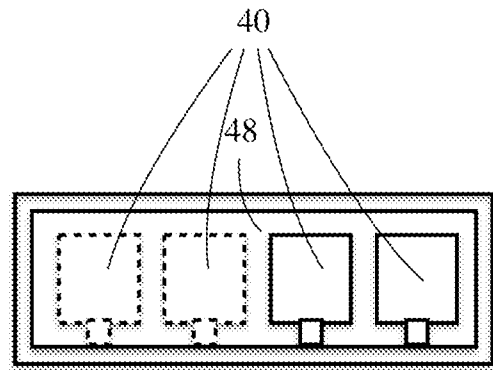

FIG. 7

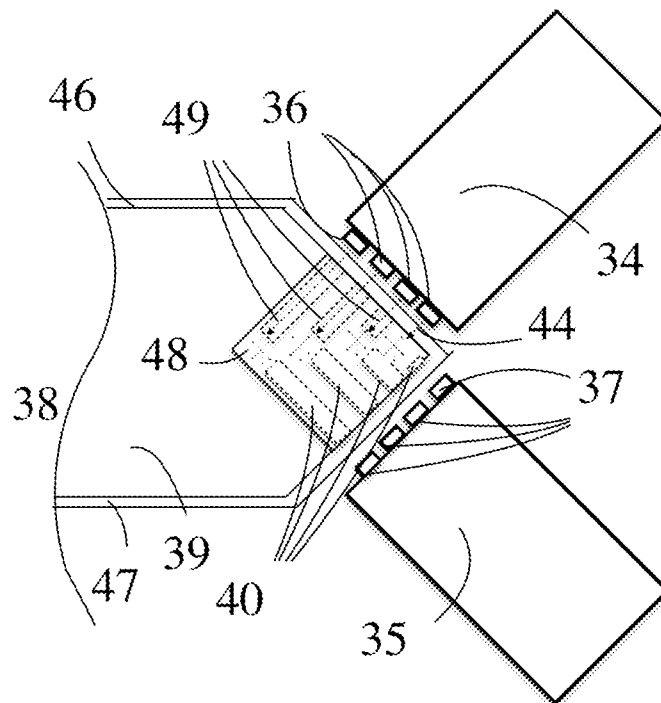

FIG. 8

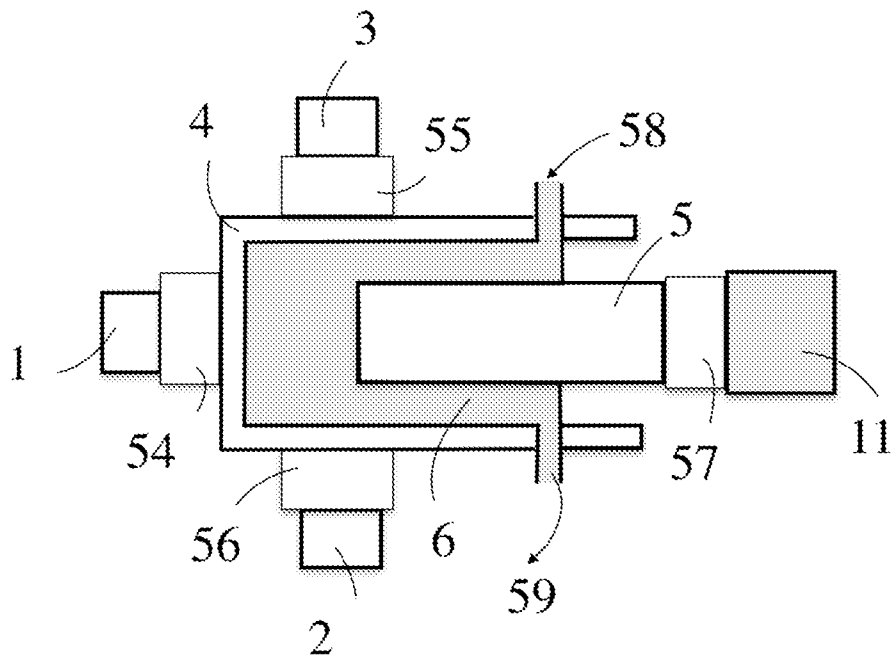

FIG. 9

## INTERNATIONAL SEARCH REPORT

International application No.

PCT/US2018/037590

## A. CLASSIFICATION OF SUBJECT MATTER

IPC(8) - G01J 3/457; G01J 3/28; G02B 6/10; G02B 6/52 (2018.01)

CPC - G01J 3/457; G01J 3/28; G02B 6/10; G02B 6/52 (2018.08)

According to International Patent Classification (IPC) or to both national classification and IPC

## B. FIELDS SEARCHED

Minimum documentation searched (classification system followed by classification symbols)

See Search History document

Documentation searched other than minimum documentation to the extent that such documents are included in the fields searched

USPC - 435/283.1; 435/287.1; 435/288.3; 435/292.1 (keyword delimited)

Electronic data base consulted during the international search (name of data base and, where practicable, search terms used)

See Search History document

## C. DOCUMENTS CONSIDERED TO BE RELEVANT

Category*	Citation of document, with indication, where appropriate, of the relevant passages	Relevant to claim No.
Y	US 2014/0193839 A1 (THE BOARD OF TRUSTEES OF THE UNIVERSITY OF ILLINOIS) 10 July 2014 (10.07.2014) entire document	1-18
Y	US 2012/0157160 A1 (OZCAN et al) 21 June 2012 (21.06.2012) entire document	1-18
Y	Parida, S. True Facets of TB Diagnosis in 2012: Hypes and Realities. European Journal of Microbiology and Immunology. 2012. [Retrieved 03 August 2018]. Retrieved from internet: < <a href="https://www.ncbi.nlm.nih.gov/pmc/articles/PMC3832067/pdf/EuJMI-02-275.pdf">https://www.ncbi.nlm.nih.gov/pmc/articles/PMC3832067/pdf/EuJMI-02-275.pdf</a> > pp. 275-281	13
Y	US 9,366,814 B2 (PACIFIC BIOSCIENCES OF CALIFORNIA, INC.) 14 June 2016 (14.06.2016) entire document	16
A	US 4,962,986 A (HOMPEL et al) 16 October 1990 (16.10.1990) entire document	1-18

 Further documents are listed in the continuation of Box C. See patent family annex.

\* Special categories of cited documents:

"A" document defining the general state of the art which is not considered to be of particular relevance

"E" earlier application or patent but published on or after the international filing date

"L" document which may throw doubts on priority claim(s) or which is cited to establish the publication date of another citation or other special reason (as specified)

"O" document referring to an oral disclosure, use, exhibition or other means

"P" document published prior to the international filing date but later than the priority date claimed

"T" later document published after the international filing date or priority date and not in conflict with the application but cited to understand the principle or theory underlying the invention

"X" document of particular relevance; the claimed invention cannot be considered novel or cannot be considered to involve an inventive step when the document is taken alone

"Y" document of particular relevance; the claimed invention cannot be considered to involve an inventive step when the document is combined with one or more other such documents, such combination being obvious to a person skilled in the art

"&amp;" document member of the same patent family

Date of the actual completion of the international search

06 August 2018

Date of mailing of the international search report

28 AUG 2018

Name and mailing address of the ISA/US

Mail Stop PCT, Attn: ISA/US, Commissioner for Patents

P.O. Box 1450, Alexandria, VA 22313-1450

Facsimile No. 571-273-8300

Authorized officer

Blaine R. Copenheaver

PCT Helpdesk: 571-272-4300

PCT OSP: 571-272-7774