

(No Model.)

S. G. HOSACK.

BENCH CLAMP.

No. 349,099.

Patented Sept. 14, 1886.

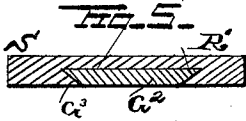
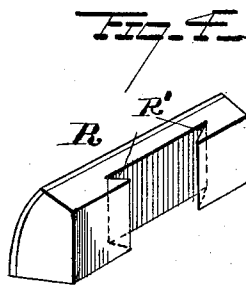
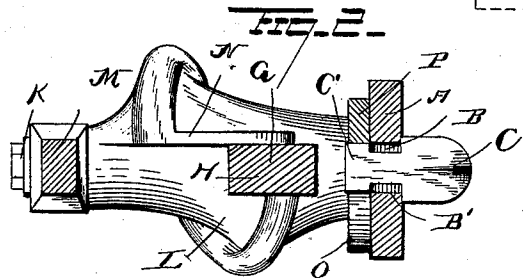
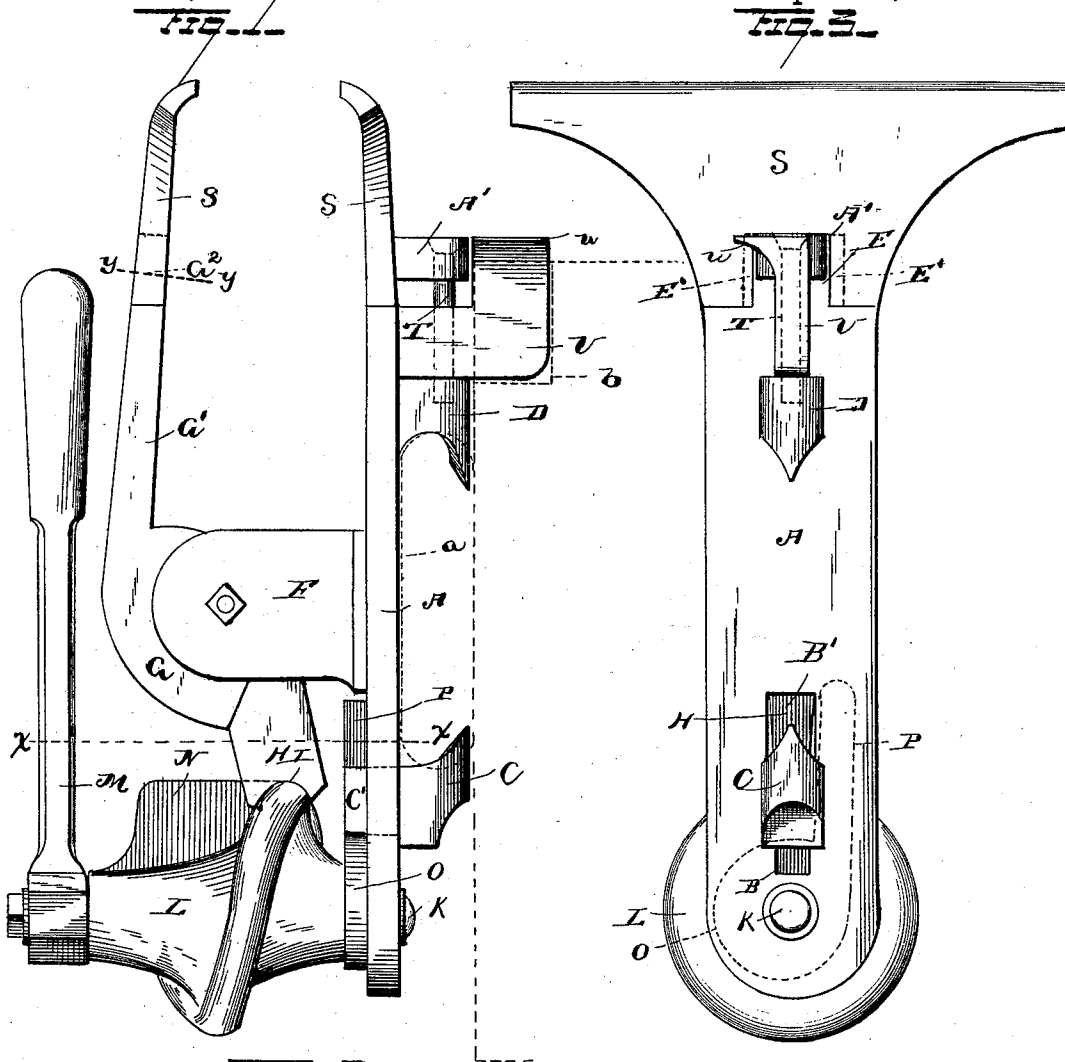

Witnesses
Wm. J. Gill
E. G. Siggers

Inventor
S. G. Hosack
 By his Attorney
C. A. Howdlo

UNITED STATES PATENT OFFICE.

SAMUEL GEORGE HOSACK, OF EAST SAGINAW, ASSIGNOR OF ONE-HALF TO
ADAM A. MEUTH, OF ANN ARBOR, MICHIGAN.

BENCH-CLAMP.

SPECIFICATION forming part of Letters Patent No. 349,099, dated September 14, 1886.

Application filed June 15, 1886. Serial No. 305,256. (No model.)

To all whom it may concern:

Be it known that I, SAMUEL GEORGE HOSACK, a citizen of the United States, residing at East Saginaw, in the county of Saginaw and State of Michigan, have invented new and useful Improvements in Bench-Clamps, of which the following is a specification.

My invention relates to improvements in bench-clamps; and it consists in the peculiar construction and combination of devices that will be more fully set forth hereinafter, and particularly pointed out in the claims.

In the drawings, Figure 1 is a side elevation of a bench-clamp embodying my improvements. Fig. 2 is a horizontal sectional view of the same, taken on the line $x x$ of Fig. 1. Fig. 3 is a rear elevation. Fig. 4 is a detail perspective view of one of the detachable clamping-jaws. Fig. 5 is a section on the line $y y$ of Fig. 1.

A represents a vertical metallic plate or casting, which is provided near its lower end with a vertical slot, B, in which works the vertically-adjustable dog C, the said dog being secured to the plate A by means of a headed stud, C', which passes through the slot B. The upper end of the slot is enlarged, as at B', sufficiently to enable the head of the stud to pass through it, and thus permit the dog to be detached from the plate.

Formed with or rigidly attached to the upper rear side of the plate A is an immovable dog, D. The extreme upper end of the plate A is provided with a vertical projecting tongue, E, having beveled edges E'.

From the center of the plate A, at the front side thereof, projects a horizontal bracket, F, in which is fulcrumed a lever, G. The said lever is provided with an upwardly-extending arm, G', the upper end of which has a vertical tongue, G², the edges of which are also beveled, as at G³.

To the lower end of the lever G is detachably secured an arm, H, the under side of which is provided with a semicircular recess, I. K represents a transverse bolt or shaft, which projects outwardly from the lower end of the plate A. On the said shaft is journaled a screw-cam, L, with the thread of which the lower end of the arm-plate H engages, the said thread fitting in the semicir-

cular recess I of the said arm. To the outer end of the screw-cam is rigidly attached a lever-arm, M, by means of which the screw-cam may be rotated. The thread or screw-blade of the cam coils once around its center or hub, and the ends of the coil are connected together by a longitudinal web, N, which strikes against the lower side of the arm H at the end of each complete revolution of the cam, thus limiting the movement of the latter.

On the inner end of the shaft K, between the inner end of the cam L and the outer side of the plate A, is journaled an eccentric cam, O, the edge of which bears under the lower side of the head C' of the movable dog. The said cam is provided with a lever-arm, P, by means of which it may be rotated, and thus caused to raise or lower the dog C, as will be very readily understood.

R represents a pair of clamping-heads, which are provided on their rear sides with dove-tailed recesses R', adapted to fit on the projecting tongues G² and E. The faces of the said clamping jaws or heads are covered with india-rubber or other suitable elastic material.

S represents another pair of clamping-heads, which are considerably larger than the heads R, and are also provided on their rear sides with recesses R', to attach them to the plate and to the lever G.

The operation of my invention is as follows: The work-bench to which the clamp is to be attached is provided on its outer side with a flange or board, a , (shown in dotted lines in Fig. 1,) the upper and lower edges of the said board or flange being curved or beveled on their inner sides, as shown. The plate A is placed against the board or flange a in a vertical position, with the dog D engaging the upper edge of the said board or flange. The cam O is then partly rotated, so as to raise the dog C and cause it to bear firmly against the lower side of the flange or board, thus securing the clamp firmly to the side of the work-bench and permitting the same to be readily detached from the work-bench when desired. If the article to be compressed by the clamp is a small one, the clamping-heads R are attached to the clamp, and the cam L is rotated, so as to cause the arm G' of the lever G to approach the upper end of the plate A, and thus

cause the clamping-head to bear firmly on opposite sides of the object, so as to hold it rigidly in place. When the object to be clamped is a large one, the heads S are substituted for the heads R. By making the arm H' of the lever G detachable from the said lever, the said arm may be removed or replaced with a new one when it becomes worn.

A bench-clamp thus constructed is cheap and simple, is strong and durable, is not likely to get out of order, and is adapted to be readily detached from and attached to the work-bench when desired.

Above the immovable dog D, on the rear side of the plate A, is a projecting lug, A', and through the said lug passes a vertical screw, T, the lower end of which is stepped in an opening in the upper side of the dog D.

U represents a bench-dog, which is provided on one side with a projecting arm, u, through the outer end of which the screw T passes, the said arm having a threaded opening to receive the said screw. The width of the arm is considerably less than the height of the space between the lug A' and the dog D, thereby adapting the bench-dog to move vertically when the screw T is turned. The bench-dog enters a recess, b, (shown in dotted lines in Fig. 2,) made in the work-bench, and as the said bench-dog is vertically adjustable it may be raised so as to project above the top of the work-bench when desired for use, or lowered with its top side flush with the upper side of the bench out of the way when not in use.

When the clamp is detached from the bench, the bench-dog may be swung against the rear side of the plate A, and thus prevented from projecting beyond the dog D and lug A', as will be very readily understood.

Having thus described my invention, I claim—

1. The combination, in a bench-clamp, of the vertical plate A, having the dogs C and D on its rear side and the bracket F on its front side, with the screw-cam L, journaled on the outer side of the plate, and having the lever M, and the lever G, fulcrumed to the bracket F, and having the lower extending arm, H, engaging the screw-cam, and the upwardly-extending clamping-arm G', for the purpose set forth, substantially as described.

2. A bench-clamp provided with the vertical slot B, and having the dog D on its rear side, in combination with the vertically-movable dog C, having the headed shank secured in the slot B, and the eccentric cam-bearing under the headed shank, for the purpose set forth, substantially as described.

In testimony that I claim the foregoing as my own I have hereto affixed my signature in presence of two witnesses.

SAMUEL GEORGE HOSACK.

Witnesses:

JOHN J. ROBISON,
JOHN SCHUMACHER.