



US00RE46320E

(19) **United States**
(12) **Reissued Patent**
Fujino et al.

(10) **Patent Number:** **US RE46,320 E**
(45) **Date of Reissued Patent:** **Feb. 28, 2017**

(54) **AIRCRAFT, TOY REPLICA, AND/OR OTHER REPLICAS WITH SURFACE ORNAMENTATION**

D308,281 S * 6/1990 Bergman et al. D2/978
D358,432 S * 5/1995 Harada D21/448
D359,472 S * 6/1995 Day D12/343

(Continued)

(71) Applicant: **Honda Patents & Technologies North America, LLC**, Torrance, CA (US)

OTHER PUBLICATIONS

(72) Inventors: **Michimasa Fujino**, Summerfield, NC (US); **Chris Osborne**, Cary, NC (US)

News & Views; "Honda Aircraft Company to Establish World Headquarters and Production Facility in Greensboro, North Carolina"; <http://www.honda.com/newsandviews/article.aspx?id=2007020934372>; 2 pages; Dated Feb. 24, 2015.

(Continued)

(73) Assignee: **HONDA PATENTS & TECHNOLOGIES NORTH AMERICA, LLC**, Torrance, CA (US)

Primary Examiner — Darlington Ly

(21) Appl. No.: **29/515,390**

(74) *Attorney, Agent, or Firm* — Pearne & Gordon LLP

(22) Filed: **Jan. 22, 2015**

(57)

CLAIM

Related U.S. Patent Documents

The ornamental design for an aircraft, *toy replica, and/or other replicas* with [exterior] surface ornamentation, as shown and described.

Reissue of:

DESCRIPTION

(64) Patent No.: **Des. 674,734**
Issued: **Jan. 22, 2013**
Appl. No.: **29/377,021**
Filed: **Oct. 15, 2010**

FIG. 1 is a perspective view of an aircraft, *toy replica, and/or other replicas* with [exterior] surface ornamentation showing our new design;

(51) **LOC (10) Cl.** **12-07**

(52) **U.S. Cl.**
USPC **D12/319; D12/342**

FIG. 2 is a left perspective view thereof;

FIG. 3 is a right perspective view thereof;

(58) **Field of Classification Search**
USPC D12/319–345; D21/447, 448; 244/13, 15, 244/34 R, 36, 45 A, 45 R, 91, 130, 198, 244/211, 215
CPC B64C 15/12; B64C 29/0033; B64D 27/20
See application file for complete search history.

FIG. 4 is a side elevational view thereof, the opposite side elevational view being a mirror image;

FIG. 5 is a top plan view thereof; and,

FIG. 6 is a front elevational view thereof.

The two different stippled shadings represent a contrast in appearance.

The broken lines in the drawings illustrate portions of the article that form no part of the claimed design.

(56) **References Cited**

1 Claim, 6 Drawing Sheets

U.S. PATENT DOCUMENTS

D153,291 S * 4/1949 Kartveli D12/343
D166,673 S * 5/1952 Kartveli D12/343
D172,880 S * 8/1954 Johnson et al. D12/342
D173,032 S * 9/1954 Johnson et al. D12/342

Matter enclosed in heavy brackets [] appears in the original patent but forms no part of this reissue; matter printed in italics indicates the additions made by reissue.

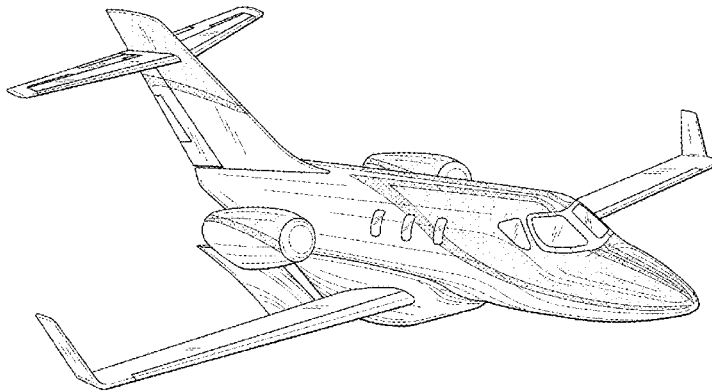

(AMENDED)

(56)

References Cited

U.S. PATENT DOCUMENTS

D414,740	S	*	10/1999	Margaritoff	D12/319
D418,105	S	*	12/1999	Margaritoff	D12/319
D431,522	S	*	10/2000	Fujino	D12/341
6,308,913	B1	*	10/2001	Fujino et al.	244/45 R
D469,054	S	*	1/2003	Fujino	D12/319
D500,281	S	*	12/2004	Aruga et al.	D12/319
D576,938	S	*	9/2008	Moon	D12/343
D589,867	S	*	4/2009	Chesne et al.	D12/343
D605,576	S	*	12/2009	Posva	D12/343
D612,792	S	*	3/2010	Guering	D12/343
D617,724	S	*	6/2010	Saint-Jalmes et al.	D12/343
D619,076	S	*	7/2010	Guering	D12/343
D624,479	S	*	9/2010	Guering	D12/343
D624,480	S	*	9/2010	Guering	D12/343
D629,349	S	*	12/2010	Hwang	D12/319
8,444,093	B1	*	5/2013	Epstein	244/134 B
2014/0339365	A1	*	11/2014	Fujino et al.	244/129.3

OTHER PUBLICATIONS

“Honda Aircraft Company to Establish World Headquarters and Production Facility in Greensboro, NC,” <http://hondajet.honda.com>, [Press Release] Feb. 9, 2007.

* cited by examiner

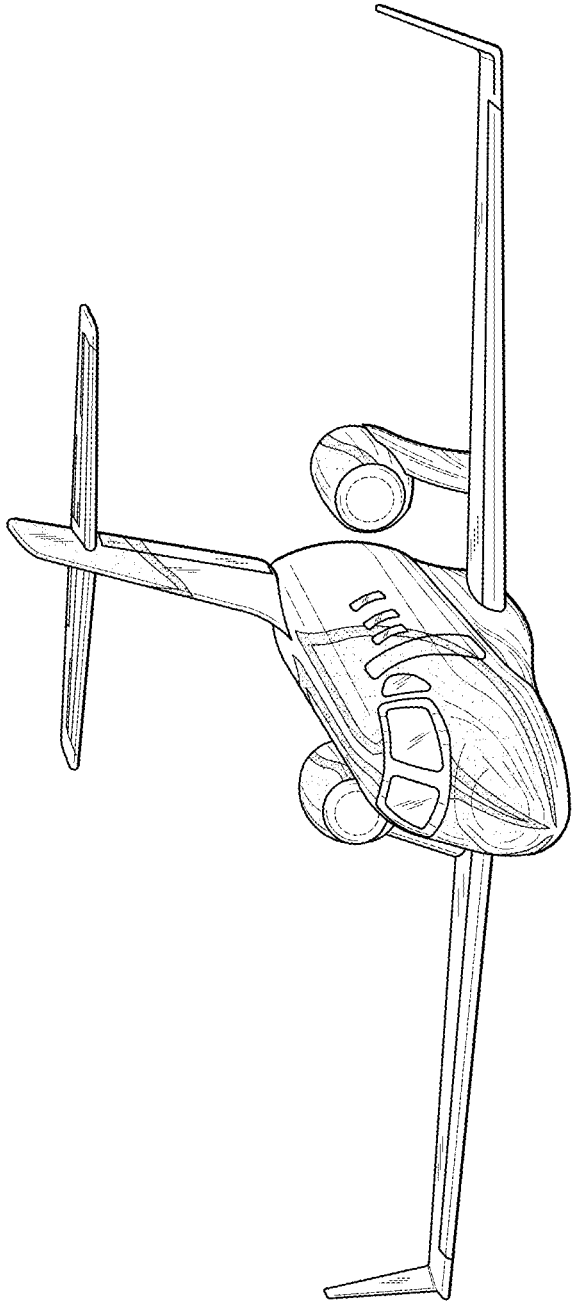

FIG. 1
(AMENDED)

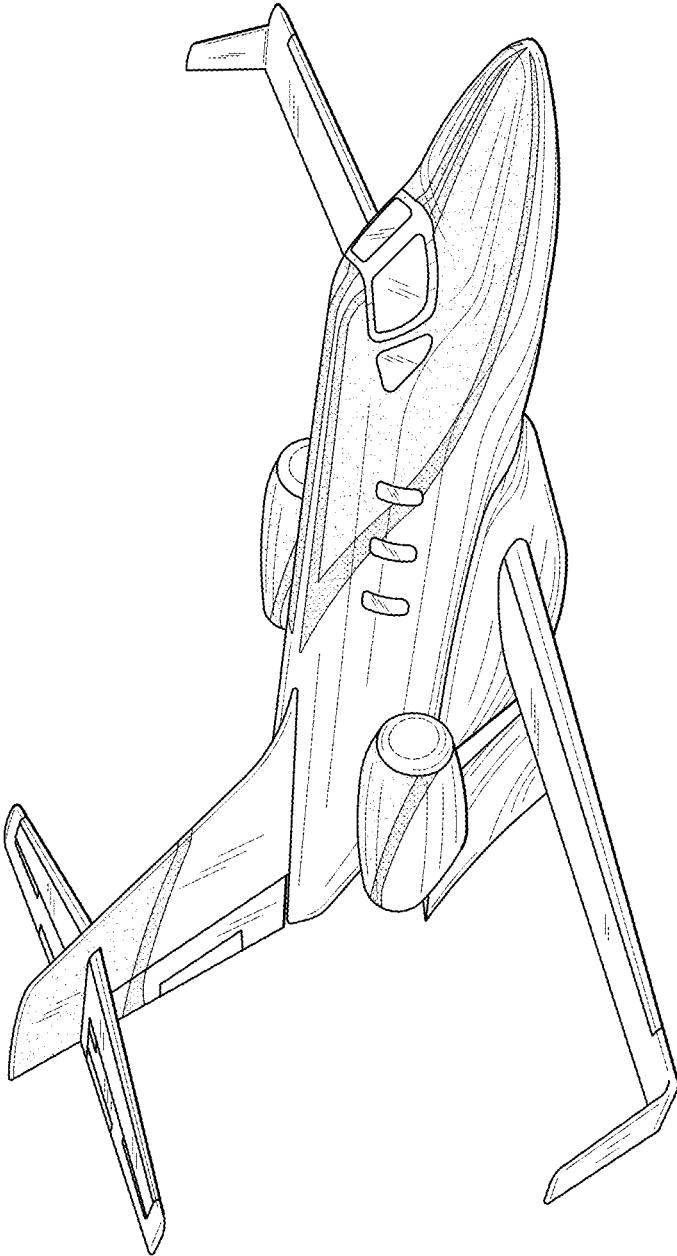

FIG. 2
(AMENDED)

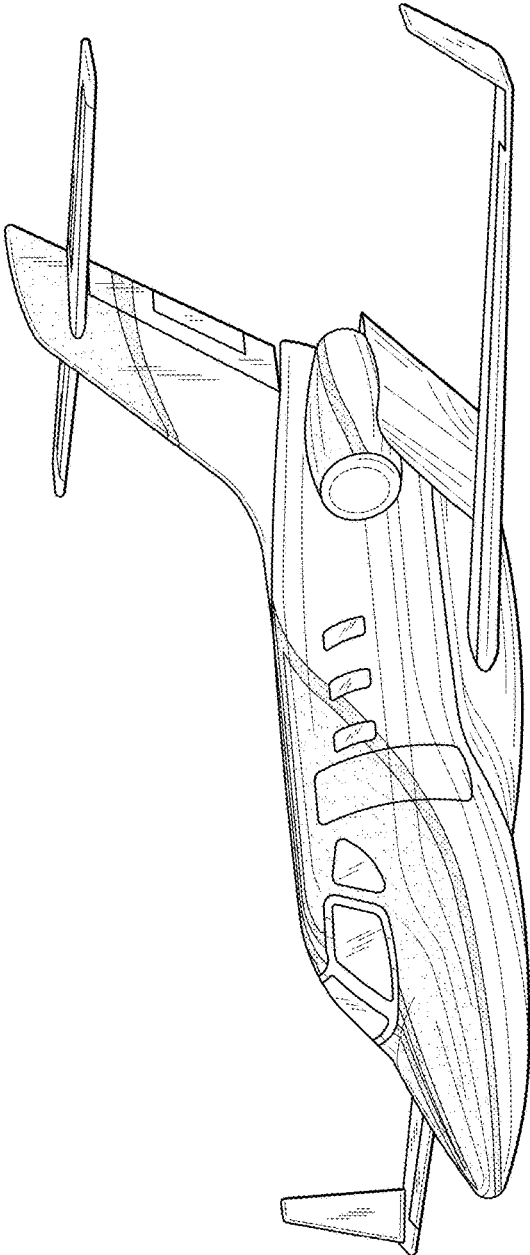

FIG. 3

(AMENDED)

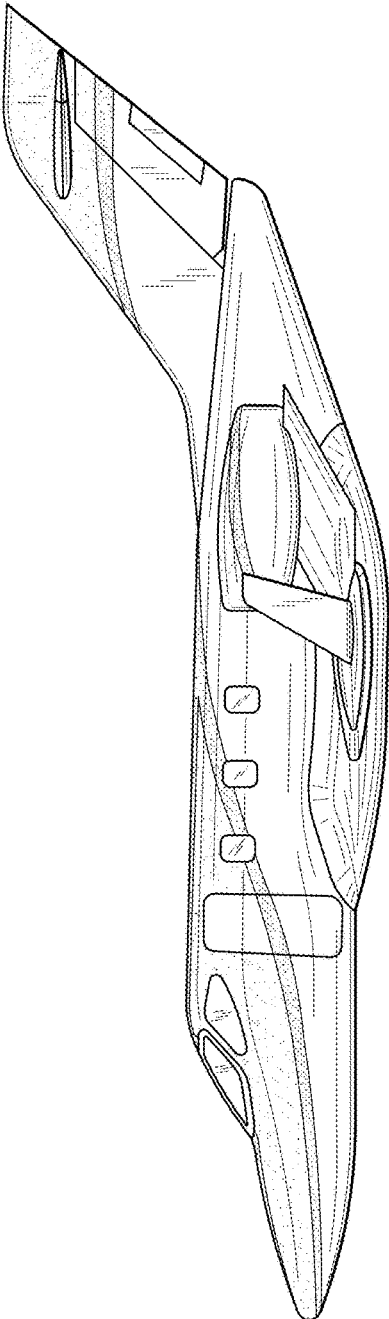

FIG. 4

(AMENDED)

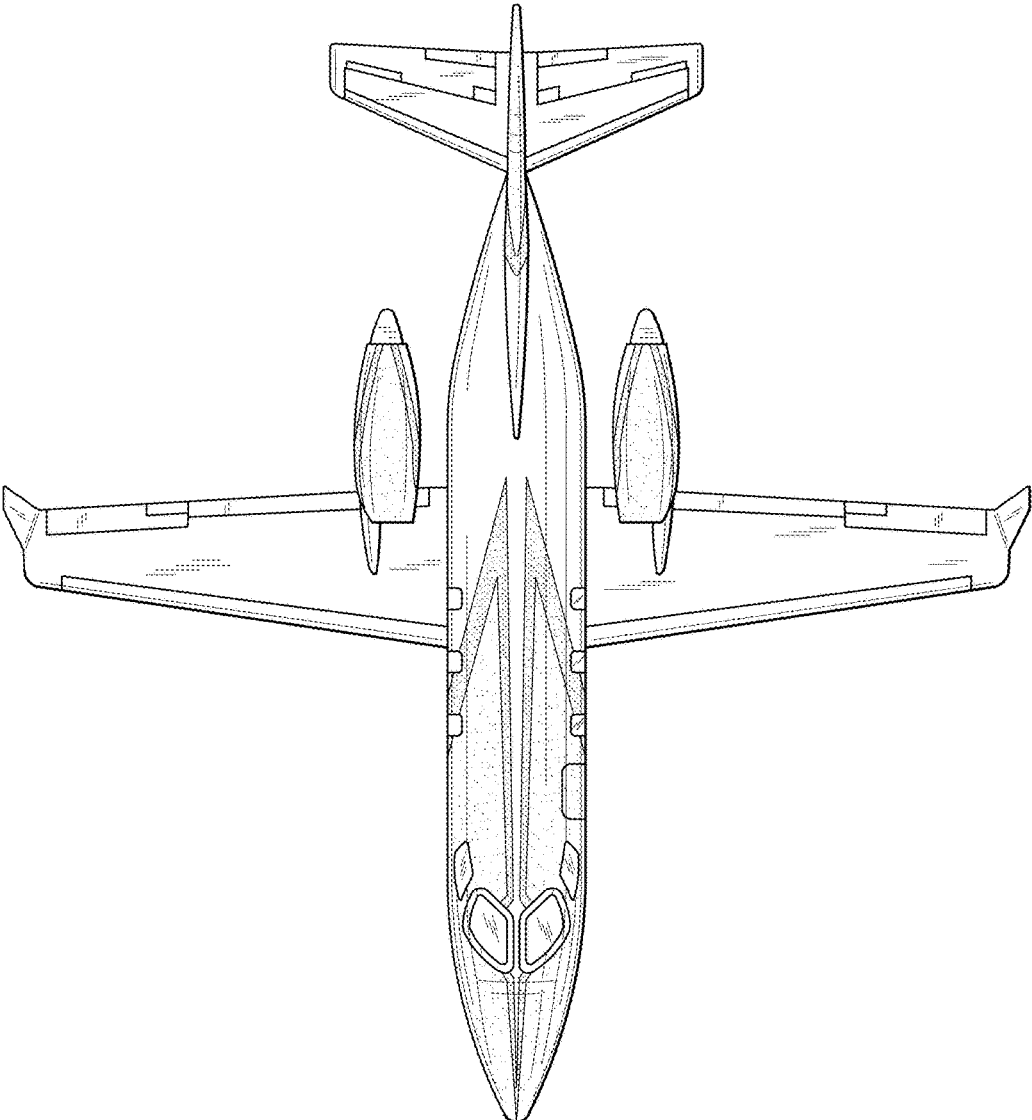

FIG. 5
(AMENDED)

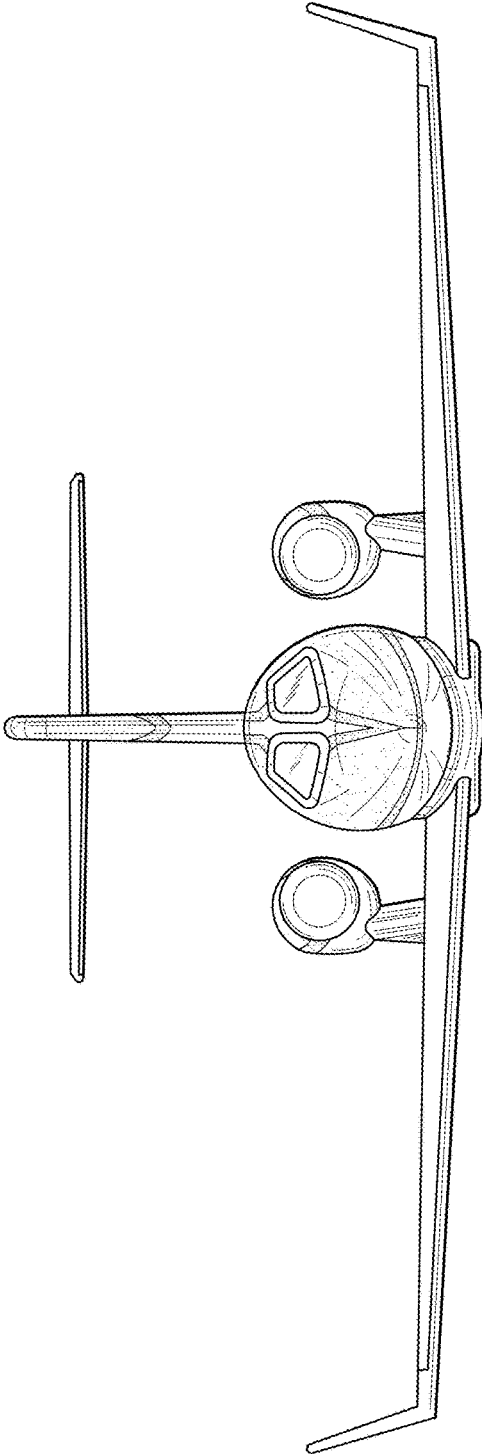

FIG. 6
(AMENDED)