



US00D343471S

United States Patent [19]
Belisle et al.

[11] **Patent Number: Des. 343,471**

[45] **Date of Patent: ** Jan. 18, 1994**

[54] **SUSPENDED LUMINAIRE**

[75] **Inventors: William W. Belisle; Herbert A. Fouke, both of Newark, Ohio**

[73] **Assignee: Holophane Company, Inc., Newark, Ohio**

[**] **Term: 14 Years**

[21] **Appl. No.: 857,302**

[22] **Filed: Mar. 25, 1992**

[52] **U.S. Cl. D26/85**

[58] **Field of Search 362/147, 404-408; D26/24, 72, 80-92**

[56] **References Cited**

U.S. PATENT DOCUMENTS

D. 300,469 3/1989 Ewing et al. D26/24
4,449,168 5/1984 Ewing 362/147 X

Primary Examiner—Susan J. Lucas
Attorney, Agent, or Firm—Brooks & Kushman

[57] **CLAIM**

The ornamental design for a suspended luminaire, as shown.

DESCRIPTION

FIG. 1 is a perspective view of my new design;
FIG. 2 is a front elevational view;
FIG. 3 is a right side elevational view;
FIG. 4 is a top plan view;
FIG. 5 is a bottom plan view; and,
FIG. 6 is a rear elevational view.

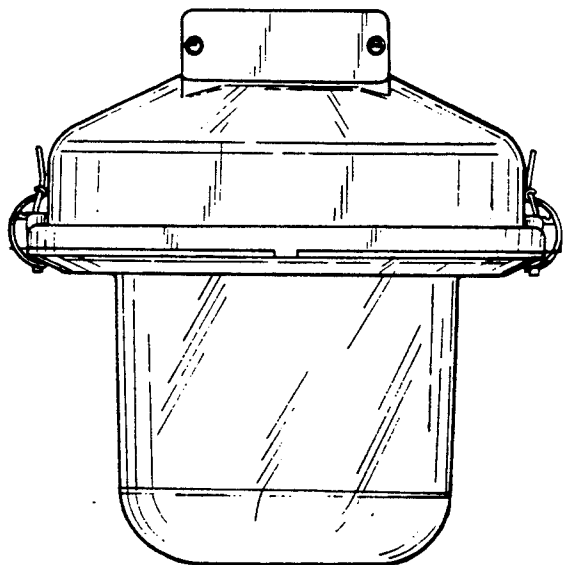
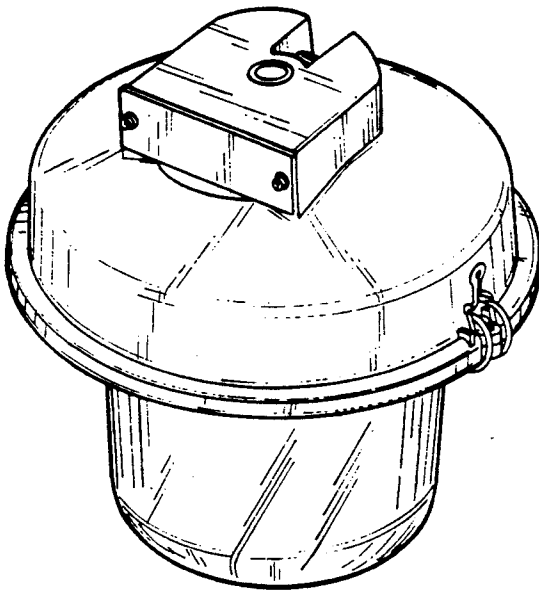

fig-1

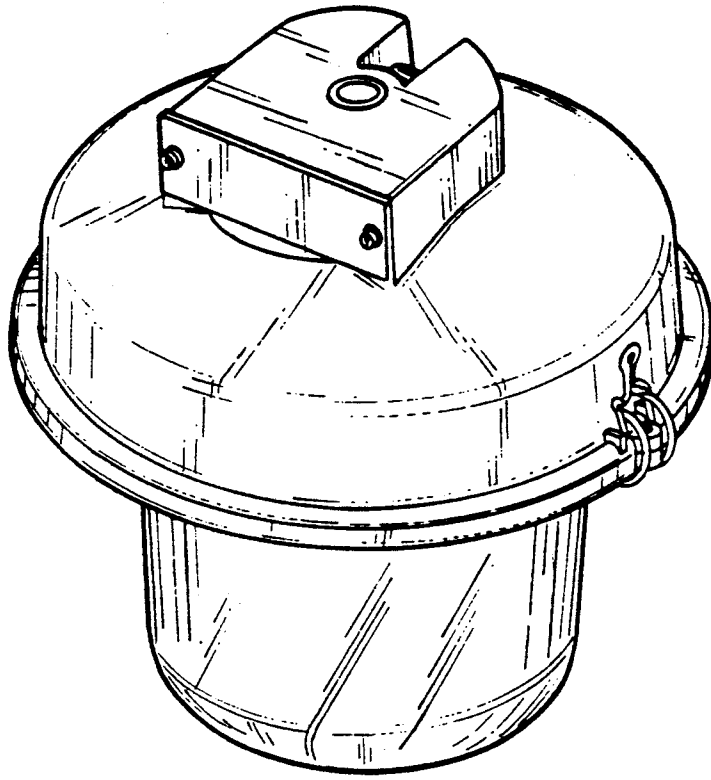
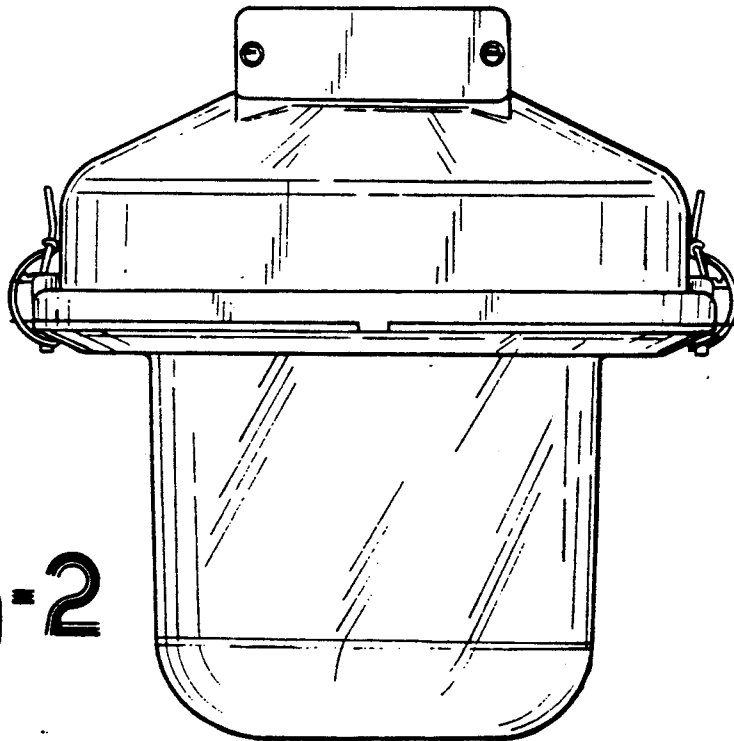

fig-2



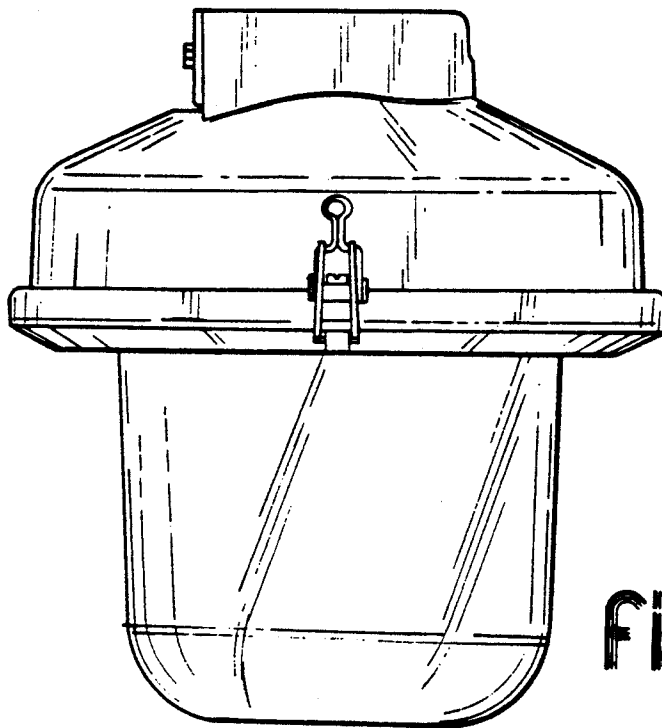

fig-3

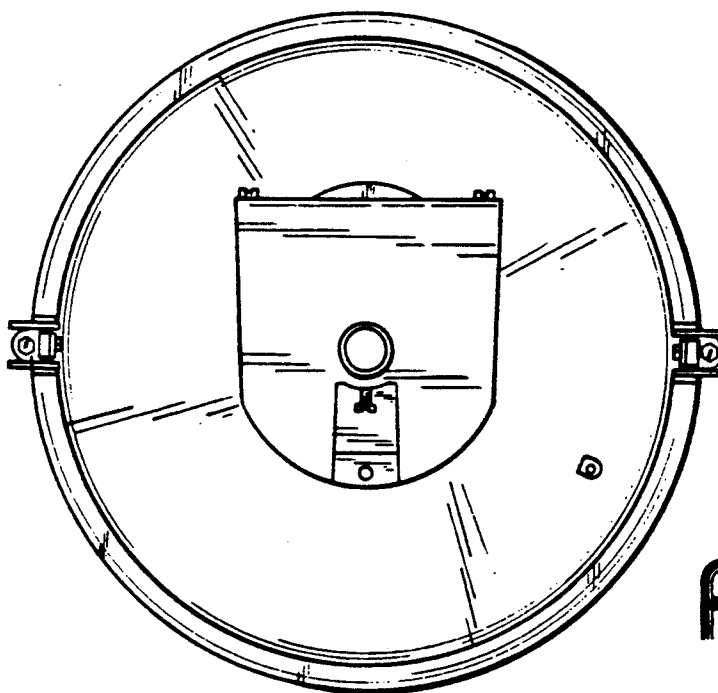

fig-4

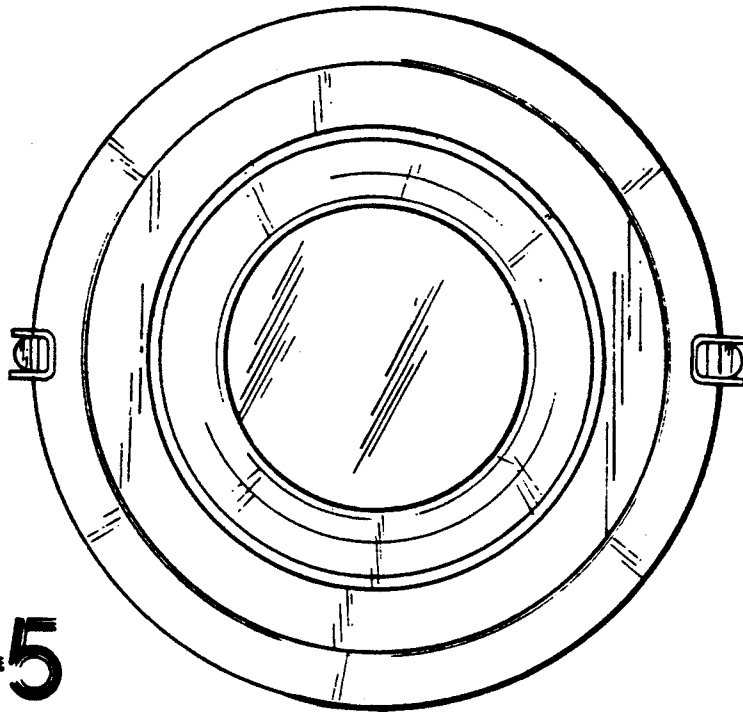

fig-5

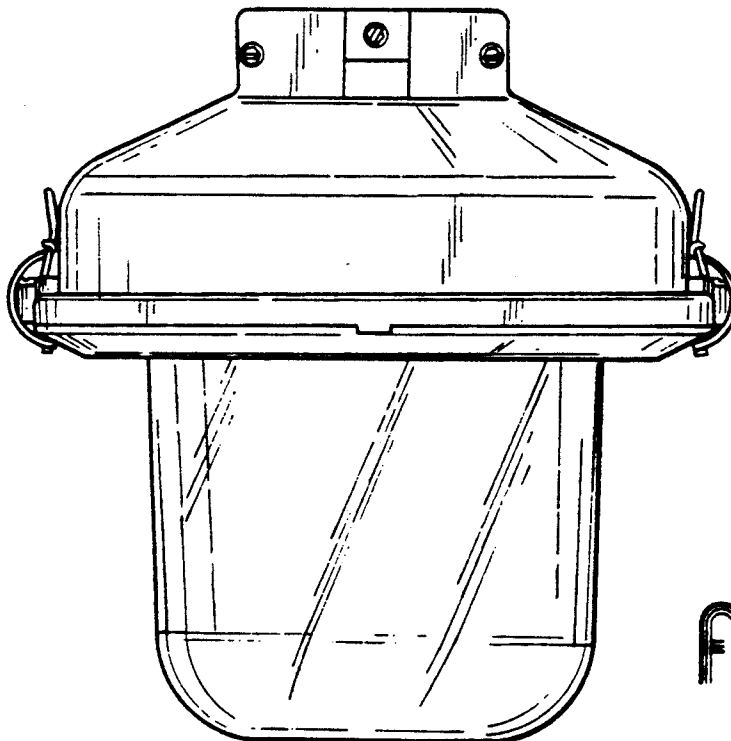

fig-6