



- (51) International Patent Classification:
A61B 5/145 (2006.01)
- (21) International Application Number:
PCT/US2014/042497
- (22) International Filing Date:
16 June 2014 (16.06.2014)
- (25) Filing Language: English
- (26) Publication Language: English
- (30) Priority Data:
61/835,759 17 June 2013 (17.06.2013) US
- (71) Applicant: NEW PARADIGM CONCEPTS, LLC
[US/US]; 5986 E. Chapine Road, Columbia City, Indiana 46725 (US).
- (72) Inventor: MCEOWEN, Edwin L.; 5986 E. Chapine Road, Columbia City, Indiana 46725 (US).
- (74) Agent: WEVER, Michael E.; Barnes & Thornburg LLP, 600 One Summit Square, Fort Wayne, Indiana 46802 (US).
- (81) Designated States (unless otherwise indicated, for every kind of national protection available): AE, AG, AL, AM,

AO, AT, AU, AZ, BA, BB, BG, BH, BN, BR, BW, BY, BZ, CA, CH, CL, CN, CO, CR, CU, CZ, DE, DK, DM, DO, DZ, EC, EE, EG, ES, FI, GB, GD, GE, GH, GM, GT, HN, HR, HU, ID, IL, IN, IR, IS, JP, KE, KG, KN, KP, KR, KZ, LA, LC, LK, LR, LS, LT, LU, LY, MA, MD, ME, MG, MK, MN, MW, MX, MY, MZ, NA, NG, NI, NO, NZ, OM, PA, PE, PG, PH, PL, PT, QA, RO, RS, RU, RW, SA, SC, SD, SE, SG, SK, SL, SM, ST, SV, SY, TH, TJ, TM, TN, TR, TT, TZ, UA, UG, US, UZ, VC, VN, ZA, ZM, ZW.

- (84) Designated States (unless otherwise indicated, for every kind of regional protection available): ARIPO (BW, GH, GM, KE, LR, LS, MW, MZ, NA, RW, SD, SL, SZ, TZ, UG, ZM, ZW), Eurasian (AM, AZ, BY, KG, KZ, RU, TJ, TM), European (AL, AT, BE, BG, CH, CY, CZ, DE, DK, EE, ES, FI, FR, GB, GR, HR, HU, IE, IS, IT, LT, LU, LV, MC, MK, MT, NL, NO, PL, PT, RO, RS, SE, SI, SK, SM, TR), OAPI (BF, BJ, CF, CG, CI, CM, GA, GN, GQ, GW, KM, ML, MR, NE, SN, TD, TG).

Published:

— with international search report (Art. 21(3))

[Continued on next page]

- (54) Title: METHOD OF MEASURING TOTAL VASCULAR HEMOGLOBIN MASS

(57) Abstract: A method of measuring total vascular hemoglobin mass. One step of the method is to store a volume of fluid to be injected using a processor. A hemoglobin value is measured in vivo on a substantially continuous basis. The method also measures a total circulating vascular volume based on the volume of fluid to be injected by detecting a change in blood concentration over a period of time upon injection of a fluid into a body. The total hemoglobin mass is calculated based on the measured hemoglobin value and the measured total circulating vascular volume.

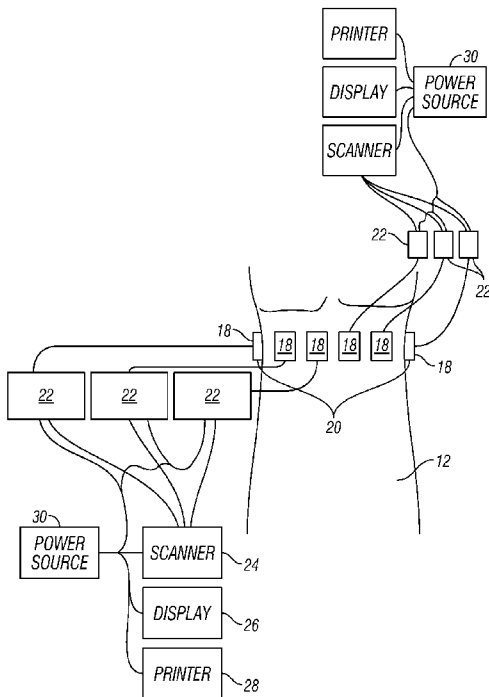

FIG. 3

WO 2014/204841 A1

- *before the expiration of the time limit for amending the claims and to be republished in the event of receipt of amendments (Rule 48.2(h))*

METHOD OF MEASURING TOTAL VASCULAR HEMOGLOBIN MASS

BACKGROUND AND SUMMARY

5 The National Trauma Data Bank Report for 2004 describes 576,247 hospital admissions for trauma between 1999 and 2004. Of these cases, 109,080 patients were admitted to the intensive care unit (ICU), 100,050 were taken directly to the operating room (OR), and 7878 died. The remaining 332,928 were admitted for general care. For many of these patients (especially for the ICU and OR patients) it was necessary to closely monitor the hematocrit with multiple phlebotomy blood samples within the first few hours. The key to providing optimal care for these challenging patients is for the trauma specialist to provide rapid therapeutic interventions based upon informed decision-making. The clinician's ability to deliver such quality care is based primarily on physical assessment skills, training, and experience, and secondly upon the degree of patient physiologic and hemodynamic data available at the moment of decision-making. There is a clear need for the clinician to have quantitative data to base his or her treatment decision.

15 The process of frequent phlebotomy consumes valuable emergency staff time and there can be substantial lag-time before results are available. Laboratory techniques have become more accurate and bedside devices have improved turn-around time for in vitro lab analysis, but these improvements have not alleviated the central problem of lack of real time information. The patient's condition may deteriorate within minutes, and reasons for the deterioration can be varied and not always obvious. Survival rates for such patients could be improved if needed data could be provided continuously, allowing better opportunity to act upon the vital information in a more timely manner. Patient monitoring methods have advanced over the decades with the development continuous arterial blood and oximetry pressure monitoring, but there remains no device that delivers other necessary physiologic data on a continuous basis.

20 In the current practice of critical care medicine, the only patient parameters that are continuously monitored are the vital signs, pulse oximetry, and temperature. Aside from oximetry, the physiologic parameters are available only through phlebotomy sampling

and laboratory analysis. The hemodynamic parameters, other than vital signs, are available only with central vascular catheterization in the ICU or the cardiac catheter laboratory. The availability of these continuous physiologic and hemodynamic parameters during patient resuscitation would improve the delivery of appropriate, timely, and cost effective patient care and, thereby, improve outcomes. Such continuous monitoring would also improve the ability of the critical care team to effectively care for multiple patients without the need for numerous and laborious repeat lab tests.

The fundamental basis of successful shock resuscitation, no matter what the cause, is the rapid assessment of vascular volume. Volume assessment, however, can be as difficult and ambiguous as it is essential to the resuscitation process. Volume assessment has been called the “cornerstone” of resuscitation. One cannot simply empty the vascular system, however, to see how much blood it contains. Therefore, throughout history, a number of techniques and methods have been utilized in the search for the best way to assess volume.

Nuclear medicine techniques for direct volume measurement have existed for a few decades, but they involve the added risk of radiation and are slow and therefore not amenable for use during resuscitation. Central vascular pressure and pulmonary artery wedge pressure monitoring became the gold standard several decades ago but are recently falling out of favor due their invasive nature and lack of statistical proof of reliability. New hemodynamic monitoring methods aimed at predicting a patient’s potential for fluid responsiveness have recently been put into practice. These include ultrasound imaging for measurement of the inferior vena cava size, arterial waveform analysis, and noninvasive cardiac output monitoring (NICOM). While these methods are a step forward in terms of hemodynamic monitoring, none are actually capable of determining circulating blood volume.

According to one aspect, the invention provides a method of measuring total vascular hemoglobin mass. One step of the method is to store a volume of fluid to be injected using a processor. A hemoglobin value is measured in vivo on a substantially continuous basis. The method also measures a total circulating vascular volume based on

the volume of fluid to be injected by detecting a change in blood concentration over a period of time upon injection of a fluid into a body. The total hemoglobin mass is calculated based on the measured hemoglobin value and the measured total circulating vascular volume using the following formula:

$$5 \quad THM = Hgb \left(\frac{g}{dL} \right) * BV(dL)$$

where *THM* is total hemoglobin mass in grams, *Hgb* is the measured hemoglobin value in grams per deciliter, and *BV* is the measured total circulating vascular volume in deciliters. The calculated total hemoglobin mass is then displayed.

Additional features and advantages of the disclosure will become apparent to those skilled in the art upon consideration of the following detailed description of the illustrated embodiment exemplifying the best mode of carrying out the disclosure as presently perceived.

BRIEF DESCRIPTION OF DRAWINGS

For the purpose of promoting an understanding of the principles of the invention, reference will now be made to the embodiments illustrated in the drawings and specific language will be used to describe the same. It will nevertheless be understood that no limitation of the scope of the invention is thereby intended. Any alterations or further modifications of the described embodiments, and any further applications of the principles of the invention as described herein are contemplated as would normally occur to one skilled in the art to which the invention relates.

FIG. 1 is a diagrammatic view of a body part having the new and improved noninvasive vital sign measurement device of the invention attached thereto utilizing a spaced apart sender and receiver;

FIG. 2 is a view like FIG. 1 of another version of the new and improved noninvasive vital sign measurement device of the invention showing a single sender and receiver;

FIG. 3 is a view of another version of the new and improved vital sign measurement device using three or more transducers;

FIG. 4 is a view of still another version of the new and improved vital sign measurement device similar to that shown in FIG. 1;

5 FIG. 5 is a view of still another version of the new and improved vital sign measurement device in which the transducers are mounted on opposite sides of a blood vessel or vessels;

10 FIG. 6 is a diagrammatic view of the new and improved multiparameter intravascular catheter vital sign measurement device of the invention for the insertion into a blood vessel utilizing separate spaced apart transducers connected to drivers and recognition analysis devices;

FIG. 7 illustrates another version of the new and improved multiparameter intravascular catheter vital sign measurement device of the invention showing a transducer/receiver with a reflector held apart by struts;

15 FIG. 8 is a view like FIG. 7 showing still another version of the new and improved multiparameter intravascular catheter vital sign measurement device of the invention showing a single sender/receiver transducer and a reflector mounted at opposite ends of a notch cut into the side of the catheter;

20 FIG. 9 is a view like FIGS. 6, 7 and 8 of still another version of the new and improved multiparameter intravascular catheter vital sign measurement device of the invention showing a sender/receiver transducer and a reflector mounted in a notch cut into the side of the catheter with a membrane or diaphragm covering and sealing the notch forming a gas filled chamber pressure sensor; and

25 FIG. 10 is a graph showing a blood volume measurement made during testing from which total vascular hemoglobin mass is determined according to an embodiment of this disclosure.

DETAILED DESCRIPTION OF SELECTED EMBODIMENTS

The new and improved noninvasive vital sign measurement device 10 of the invention is a medical device for supplying vital sign measurements for any purpose and in any setting where such information is useful to medical clinicians conducting physical
5 examinations or monitoring patients (inpatient, outpatient, or ambulatory), whether in well-equipped hospitals, clinics, or on a battlefield. The invention would allow the monitoring of vital signs continuously. In the vascular application of the device, vital signs that can be measured would include arterial and venous blood pressure and pulse, blood flow velocity, and blood density. Peripheral vascular resistance could be calculated and displayed using
10 data from the device. More conventional equipment could be mated with the device in order to continuously monitor such things as temperature and oxygen saturation. Other potentially measurable pressure parameters could include the extravascular space, intracranial space, intrathoracic (vascular, airway, and pleural) space, or any confined body cavity, depending upon the particular configuration of the device and where it is mounted upon or applied to
15 the body. Examples of confined body cavities would include possibly the urinary bladder, gallbladder, intra-abdominal, ocular, and more probably extremity fascial compartments. Additional measurements that may be obtainable by the device could be other vascular parameters including possibly intracardiac chamber pressures and more possibly central venous pressures.

20 When arterial blood pressure is measured and monitored, both systolic and diastolic blood pressure should be monitored beat-by-beat. This information would be useful in evaluating routine vital signs, hypertension, hypotension, and shock from any cause. The instantaneous monitoring by the application of the invention would provide a means by which the effectiveness of pharmaceutical intervention and surgical intervention
25 could be immediately assessed. Venous and extravascular space monitoring can be used to determine tissue perfusion and lymphatic obstruction, as well as the general state of hydration of the patient. Vascular monitoring will provide information regarding patient shock from any cause, e.g., sepsis, blood loss, and autonomic malfunction. Data from the combined monitoring of arterial pressure and blood flow could be used to calculate vascular

resistance. For the clinician, knowing the level of vascular resistance and continuously monitoring blood pressure are key factors in determining not only the cause of shock but also the best course of treatment in each circumstance.

5 Intrathoracic measurements could include intrapulmonary and intracardiac, as well as pleural and pericardial space pressures. Measurement of large, medium, and small airway and alveolar space pressures would give physicians both diagnostic and treatment monitoring tools for acute and chronic lung disease. The device could be used to confirm endotracheal tube placement. Intrapleural pressure measurements would provide data for rapid diagnosis or confirmation of hemothorax and pneumothorax, and could be used in
10 both hospital and prehospital settings to help determine the urgency with which these conditions should be treated.

Intracardiac pressure measurements would allow diagnosis of valvular failure, cardiomyopathy, congenital defects, myocardial ischemia/infarct, and congestive heart failure. Chamber pressure measurements together with echocardiogram data and
15 pulmonary vascular readings would yield vital information regarding the etiology of any of the above maladies previously available only with cardiac catheterization.

More convenient and accurate ocular pressure measurement would allow physicians improved means of diagnoses and treatment monitoring of ocular diseases such as glaucoma.

20 Intracranial pressure measurements would most likely be extremely difficult because of signal attenuation through bone; however, if possible, it would give physicians a rapid estimate of tissue pressure, ventricular pressure, and vascular space pressure when dealing with patients suffering from head injury or stroke, and post-operative neurosurgical patients. It would also be useful in the diagnosis of such maladies as pseudotumor cerebri
25 and hydrocephaly.

Currently, most all of the measurements above can be obtained accurately only by the use of expensive and/or invasive procedures. Sphygmomanometer blood pressure cuff readings are accurate in normal and high ranges, but cumbersome and slow, as

well as painful for many patients. For automatic blood pressure cuff devices, the International Electrotechnical Commission has set international standards regarding strict limits on the pressure to which the cuff can be inflated. And, in order to avoid tissue damage and considerable discomfort to the patient, they have also set limits on the period of rapid
5 inflation/deflation cycles. Blood pressure cuff readings are in fact contraindicated for post-mastectomy patients in the arm on the affected side. However, when vital signs are unstable or potent drugs are needed in order to maintain blood pressure, time-consuming invasive procedures are required for continuous monitoring. In the emergent setting, clinical decisions must often be made long before there is any x-ray or echocardiography evidence
10 available and long before invasive vascular monitoring catheters can be inserted and calibrated.

Vital sign data which can be obtained by the device are useful in intensive care units, operating rooms, all prehospital settings, emergency departments, dialysis centers, medical practice offices, medical research, pulmonary and veterinary clinics, in
15 military installations or on a battlefield, and in aerospace installations for monitoring pilots and astronauts at work. On an ambulatory basis, such data would also be very useful in everyday life and in the sports world. We currently have no convenient way to monitor the businessman, the homemaker, or the athlete in action.

The function of the device depends upon subtle, but measurable, changes in
20 acoustic velocity that occur as a result of changes in density of the medium through which the sound wave is propagating. The noninvasive device would measure acoustic transit times, and thereby measure density within fluid or gas-filled body organs/structures/vessels. By monitoring transit times and minute shifts in transit time in rapid sequence (10 to 100 times per second) during all phases of systole and diastole, such measurements, if made
25 with precision, would result in accurate, reliable, and continuous vital sign data.

In addition to arterial and venous pressure readings, this principle would in like manner apply to the measurement of pressure in gas-filled structures such as pulmonary airways and possibly the bowel lumen. Similarly, ocular, intrauterine, and possibly extremity compartment pressures would be amenable to measurement. Intracranial

pressures may be measurable with this technique as well. The acoustic frequency specifications and configuration of the device would be altered according to the purpose at hand; e.g., airway pressure measurement would require much lower frequencies for better intrathoracic sound penetration and since acoustic velocity is much slower in gas than in fluid.

5
10
15
The measurements are based upon the characteristics of acoustic waves as they propagate through biologic tissue or fluids or gases. Since acoustic velocity increases with the density of the medium through which it is propagating, then there must be a measurable change in acoustic velocity through a fluid or gas-filled vessel, cavity, or compartment as the density within changes. Minute blood density fluctuations will occur as the blood pressure cycles between systole and diastole. Therefore, there must be a measurable change in the acoustic wave propagation velocity through the blood as the pressure changes. The common equation, $V=D/T$, indicates that changes in velocity (V) are inversely proportional to changes in transit time (T) over a fixed distance (D). If the measurements were done with precision, then the device output would consist of highly accurate, beat-by-beat digital pressure readings in the case of vascular application of the device.

20
The UNESCO equation describes the relationship between acoustic wave velocity and pressure in water. The equation also takes into account other factors that contribute to the density of the fluid, such as the salinity and the temperature. Although fluids (blood included) are considered incompressible, the equation shows that there should be minute but measurable changes in velocity associated with changes in pressure, even within the human blood pressure range of 0 to 300 mmHg.

25
To form theoretical support for this method, the space between two hypothetical transducers was assumed to be 10 cm. The UNESCO equation was then used to calculate acoustic velocity at pressure increments of 10 mmHg assuming fluid temperature is 37.degree. Celsius, salinity is 9 psu (practical salinity units) or ppt (parts per thousand), and variable pressure is expressed in kPa. Calculations using the formula $V=D/T$ indicate that in order for the device to have precision to within 1 mmHg, it must be capable

of detecting shifts in transit time of roughly 10 picoseconds. Trending of the pressure could be achieved by the detection of shifts of approximately 100 picoseconds.

Referring now to FIG. 1, the monitoring device 10 is shown attached to a body part 12 from which the blood pressure and other vital signs are monitored. Body part
5 12 can be any body part including the head, the neck, the chest, the abdomen, the arms, and the legs, to measure pressure in any blood vessel in good proximity to the skin's surface. Two transducers 14, 16 are spaced apart, longitudinally in line with a vessel, a specific and fixed distance, e.g., 10 cm, and applied to the skin using an acoustic conductive medium. By measuring the transit time of the acoustic signal between the two transducers 14, 16, the
10 velocity of the sound wave through the tissue can be calculated using the equation $V=D/T$, where V equals the velocity; D equals the space between the transducers 14, 16; and T equals the time the signal takes to propagate (transit time) between the two transducers 14, 16. One transducer 14 (the sender) generates the input signal and the other transducer 16 (the receiver) generates the output signal.

15 Utilizing this pitch-catch method, with the two transducers 14, 16 both serving the dual function of sender and receiver, measurements of both upstream and downstream transit times would be achieved. Blood flow velocity would be calculated in a conventional manner using the difference between downstream and upstream transit times. Since transit time oscillations resulting from blood flow are magnitudes greater than transit
20 time oscillations associated with cyclical pressure changes, these flow oscillations must be effectively cancelled out of the calculation by the summation of downstream and upstream transit times. The data resulting from this summation would reflect the effect of pressure fluctuations on transit times. The summation would magnify the observed systolic/diastolic shift in transit times by a factor of two while canceling the effect of blood flow. Also, this
25 technique would reduce artifact resulting from body movement and intravascular turbulence. Mathematically this can be expressed as follows:

$$T_{\text{sub.total}}=(T_{\text{sub.downstream}}+T_{\text{sub.upstream}})/2$$

Factors determining total transit time are (1) acoustic velocity due to blood density, (2) acoustic velocity as it is influenced by blood flow and artifact produced by body

movement and vascular turbulence, and (3) the velocity of the acoustic wave as it passes through the surface conductive medium and the skin and subcutaneous tissues.

$$V_{\text{sub.total}} = V_{\text{sub.1}} + V_{\text{sub.2}} + V_{\text{sub.3}}$$

5 $V_{\text{sub.3}}$ (tissue and conductive medium contribution to velocity) will remain constant. $V_{\text{sub.2}}$ (blood flow and artifact contribution to velocity) can be readily measured and canceled out of the equation by summing the velocity in both directions, thereby eliminating its contribution to the equation. Therefore, $V_{\text{sub.1}}$ (density contribution to velocity) remains as the only variable factor when transit times are measured, and, within blood vessels, pressure will be the only density determining factor that fluctuates on a
10 moment by moment basis. $V_{\text{sub.total}} = V_{\text{sub.density}} + V_{\text{sub.constant}}$

$$\text{Therefore: } \Delta V_{\text{sub.total}} = \Delta V_{\text{sub.density}}$$

Since density--as it is determined by the momentary values of hematocrit, salinity, and temperature--remains fixed, then it follows that any momentary velocity fluctuations are a result of fluctuations in pressure alone. Thus:

15 $\Delta V_{\text{sub.density}} = \Delta V_{\text{sub.pressure}}$ and therefore:
 $\Delta V_{\text{sub.total}} = \Delta V_{\text{sub.pressure}}$

Therefore, any momentary fluctuation in transit times will also be a result of fluctuations in pressure. These fluctuations in transit times can thus be expressed mathematically as: $\Delta T_{\text{sub.total}} = \Delta T_{\text{sub.pressure}}$ and since:
20 $\Delta T_{\text{sub.total}} = (\Delta T_{\text{sub.downstream}} + \Delta T_{\text{sub.upstream}}) / 2$ then
therefore:

$$\Delta T_{\text{sub.pressure}} = (\Delta T_{\text{sub.downstream}} + \Delta T_{\text{sub.upstream}}) / 2$$

Signal processing and adequate sound conduction through the skin and subcutaneous tissues to and from the structure of interest are critical steps involved in
25 ensuring the accuracy and reliability of the device. Factors such as incorrect device placement, obesity, and edema will interfere with acoustic conduction and possibly render the device ineffective. In an aerospace application or during sports participation, high G forces may effectively dislodge the device from its proper position. The use of bi-directional

"pitch-catch" transducers will reduce the error resulting from imprecise device placement upon the body. This method will also likely reduce artifact from body movement.

5 The output signal would appear as an amplitude spike (buried within noise) that moves to and fro along the instrument's time scale indicating at its limits a systolic and diastolic transit time for each cycle. Shorter transit times are associated with the systolic pressure and longer transit times with the diastolic pressure. The point along the larger transit time scale where these minute pressure-related transit time shifts will be observed will drift as blood density drifts due to changing physiologic values such as hematocrit, salinity, and temperature. This drifting must be accounted for by the continuous and precise
10 monitoring of blood density as it is affected by these varying physiologic values. This can be done using the precision acoustic transit time measurements described earlier, and it is essential for continuous calibration of the device as base-line drifting of blood density occurs.

15 Ideally, calibration measurements will be made by observing the density of venous blood while it is under the influence of zero increased vascular pressure, i.e., at atmospheric or ambient pressure. As the device operates in its vascular mode, continuous calibration and ultra-precision is the core of its design and function. To summarize, the core of the device design and function depends upon ultra-precision and continuous calibration for changes in temperature and also for changes in transducer separation distance (if not
20 fixed by use of a rigid housing). (See page 34.)

According to the UNESCO equation, there is a 98.4 picosecond change in the transit time across a 10 centimeter distance for every 10 mmHg change in pressure. However, the variability of the above mentioned physiologic values may result in as much as several hundred nanoseconds of drift in transit times. According to the UNESCO
25 equation, when salinity is fixed at 9 psu, a change in body temperature of 1 degree Celsius would alter transit time by about 75 nanoseconds (a scale that is magnitudes greater than transit time shifts resulting from incremental changes in pressure). Similarly, with temperature fixed at 37.degree. Celsius, alterations in salinity of only 0.1 psu would result in a change in transit time of about 4.25 nanoseconds. These values were calculated using

velocity data obtained from the UNESCO equation at the National Physical Laboratories (NPL) interactive website and using the previously noted common equation, $V=D/T$. Such large scale changes in blood density would of course occur over a period of hours and not milliseconds and therefore should not affect momentary pressure readings. However, if
5 blood density alterations are not monitored precisely and continuously, then the minute fluctuations in transit time related to pressure oscillations would have no baseline or frame of reference and would be useful only for pulse detection. Even trend monitoring would be difficult as such without a solid frame of reference.

Ideally, in order for the peak and trough (systolic and diastolic) density
10 values to be meaningful, the measurement of baseline density must be performed within the observed fluid or gas when it is under zero increased pressure. In vivo, however, blood or other physiologic fluids or gases are rarely without the influence of at least minimal pressure. This fact increases the challenge of device calibration. However, it can be predicted intuitively that there may be a measurable "zero" or baseline density that could be
15 monitored by the device by selectively "capturing" venous system readings during the lowest point in the cycle (most likely during inspiration at end-diastole). It can also be predicted that there may be a mathematical relationship between peak and trough arterial and venous density and flow values and the baseline density value. This prediction allows for the potential determination of the baseline calibration density by means of extrapolation.
20 Another means of device calibration, much less desirable because of its semi-invasive nature, would be the measurement of the density of an in vitro blood sample at atmospheric pressure.

The best method for ultrasound (US) or electromagnetic (EM) pulse delivery and detection must be determined. Potential devices would include conventional high
25 frequency ceramic piezoelectric US transducers, RF (radio frequency) US transducers, polymer piezoelectric US transducers, IR (infrared) receivers, and Fiber Bragg Grating (FBG) Laser receivers, not excluding other existing and/or future transducers or sensors which are found to be applicable. All of these devices are referred to herein as "transducers" and/or "sensors." The frequency and amplitude chosen for the input signal, as well as the

mechanism of its delivery, will depend upon requirements for patient safety and requirements for proper tissue penetration and conduction of the acoustic wave.

5 The device must be capable of detecting transit time shifts as low as 9.8 picoseconds in order for it to have resolution of 1 mmHg pressure, which would be ideal for medical purposes. Medical ultrasound typically operates in the frequency range of 1 to 10 MHz. This device will likely require a higher frequency acoustic input signal for accuracy. However, lower frequencies better penetrate tissues with less attenuation.

10 Input signal attenuation and penetration varies between tissue types and according to the frequency. For example, according to Dowsett, Kenny and Johnston: The Physics of Diagnostic Imaging, chapters 17, 18; attenuation coefficient/frequency (dBcm-1 Hz-1) are listed for the following tissue types: muscle: 1.8-3.3; fat: 0.6; brain: 0.9; blood: 0.2; bone: 20. These variations in signal attenuation can be exploited in order to enhance the quality of the output signal, since blood is a better conductor of acoustic energy and less prone to signal attenuation when compared to biologic tissues. However, signal attenuation is much higher at high frequencies. Nevertheless, there exists enough of a difference between its value in blood and tissues that the principle remains the same. Ideally, the chosen frequency would attenuate within the skin and subcutaneous tissue before directly reaching the receiver yet conduct effectively along the vessel to the receiver. This would greatly enhance the signal-to-noise ratio.

20 Signal input from the sender must consist of brief pulses or "clicks" generated at specific intervals (e.g., 10 to 100 times per second) in order to detect all phases of the pressure cycle. The brevity of the impulse will be important for precision and will guide the choice of acoustic energy to be considered for use in the device. There will likely be a need to focus the ultrasound beam in such a way as to effectively maximize the intravascular acoustic travel distance (the distance that the sound wave actually travels within the blood vessel on its path to the receiving transducer). Such focusing will probably take the form of a simple transducer array, possibly requiring the use of more than one frequency.

Also for the sake of precision, the operational goal of device 10 is for the sending transducer to create a focused shock wave "click," and to clock its transit time within the blood to the receiving transducer. Since sound waves travel in all directions from their point of origin, it would be difficult to know the exact length of the intravascular sound wave path. However, fixing the transducer separation by using rigid housing and using a technique such as Time-Reversal Mirrors should define the wave path well enough to accomplish the desired level of precision. Maximizing and closely defining the length of the sound wave path is a crucial step for the accurate determination of intravascular sound speed. Detection and timing of the first arrival wave would indicate the transit time for the most direct path between transducers. Since sound speed is higher in blood than in the surrounding tissues, then this first arrival wave would be considered to have passed through blood.

Referring to FIG. 2, there is shown the device 10 of the invention in a single transducer variant comprising a transducer 18 applied to the skin of a body part 12 using an acoustic conductive medium such as above described. The single transducer functions as the sender, generating the acoustic input signal and as the receiver, generating the output signal. The single transducer 18 could yield the same data as the two-transducer method, above described. This may be accomplished by measurement of the transit time (the echo) of the acoustic wave to and from the far side of the specific vessel as the wave reflects off the vessel wall interface. Using this method, the angle of the transducer axis to the vessel is critical. The transducer must remain as close to perpendicular as possible to the plane of the vessel in order to eliminate errors caused by blood flow. As this method may not be as precise as the two-transducer method, it may be more useful for trending.

Phase-shift detection could be used as another signal processing technique in both the single and two-transducer methods to detect transit time shifts in vessels, chambers, body cavities and compartments, or airways. Since the velocity of acoustic transmission changes with varying pressure, the phase of the reflected or transmitted wave would shift proportionately with changes in transit time and therefore would also shift with changes in pressure. When using this phase-shift detection technique during vascular system or static

fluid compartment measurement, very high frequencies (most likely within the range of 50 MHz to 7.5 GHz, but not excluding higher or lower frequencies) would be required in order to ensure precision. When analyzing the pulmonary or pleural spaces, lower frequencies (probably ranging from 100 KHz to 1 MHz, but not excluding higher or lower frequencies) would be required.

Such a phase-shift detection technique would not truly utilize the Doppler-effect in its detection of phase shift. Since there is no flow involved within static compartments, then there is no Doppler-effect possible. Within vessels, however, the desire is to cancel out any effect of flow and motion artifact. Therefore, while phase-shift may still be a measurable quantity, the Doppler-effect would not be applicable in either the vascular setting or the static compartment setting.

The single transducer transit time and phase-shift detection methods may be more suitable for measurements of static compartments or hollow organs within which flow is not a significant factor. They may be less suitable for vascular pressure measurements where they cannot easily cancel out noise caused by flow.

IR, RF, and/or Laser technology may also be used in transducer design for the single or two-transducer methods. The arrangement of the sender and receiver transducers would be as in FIGS. 1 and 2. Sensor function could be enhanced with the use of Laser technology with Fiber Bragg Gratings (FBG's) tuned to a specific US frequency. FBG Laser may be especially useful in sensor design due to its capability of sensing high frequencies and its resistance to RF interference.

A third type of arrangement for the transducers utilizes three or more transducers, one sender and two receivers arranged in the order, receiver-sender-receiver, as they lay longitudinally over the vessel. Again, these transducers could be of piezoelectric design or could use any of the other advanced technology above described. The two receiving transducers would clock the US wave front as it passes upstream and downstream from the centrally located sending transducer. The velocity values would be summed in order to cancel out the effect of blood flow and to separate it from the effect produced by

pressure fluctuations. Like the two-transducer technique, this technique--given very specific placement of the transducers and chosen frequencies--would also take advantage of the fact that the attenuation coefficients of biologic tissues differ from that of biologic fluids.

5 However, accuracy would likely not be as precise as with the two-transducer method since the wave paths upstream and downstream do not cross the same section of vessel, and thus cancellation of turbulence-induced signal variations may not be as effective. See FIG. 3.

Each of the sensors 14, 16 and 18 and each of the monitoring devices 10 of the invention illustrated in FIGS. 1-3 are connected to a computer that is programmed with recognition and analysis software. Depending upon the function of the sensor 14, 16 or 18, 10 i.e., whether the sensor is a sender, a receiver, or both, the computer software will differ as to each recognition and analysis computer 22 to receive the signal from its individual sensor 14, 16, 18 and convert the same into a measurement of arterial and venous blood densities and blood flow velocities, blood pressure, pulse rate, vascular resistance, cardiac output, pressure pulse wave velocity, and the like. The display will include both instantaneous 15 measurements and a plot of each measurement versus time.

Scanners 24 are provided to scan each of the computers 22 sequentially from about 10 to about 100 times per second, depending upon the particular clinical application. Each of the scanners would be operatively connected to a display 26 that would display the data from each of the sensors 14, 16, 18 of each of the measurements, in the form of both 20 instantaneous measurements and the historical trends of each measurement. The display would be combined with a selection switch by which each measurement and trend could be selectively displayed.

Attached to each display would be a printer 28 which would print out current vital signs and a continuous record of highest, lowest, and trends of each measurement, as 25 well as trends for each patient and each location of a sensor 14, 16, 18.

Each of the sensors 14, 16, 18, each of the recognition and analysis computers 22, each of the scanners 24, each of the displays 26, and each of the printers 28 are connected to a power source 30.

In the single sensor device 10 illustrated in FIG. 2, the sensor 16 is connected to a single recognition and analysis computer 22 which is connected directly to a display 26 and to a printer 28.

Precise measurement of biologic fluid density is the critical step in ensuring accuracy by way of continuous calibration for the device using any of the above methods. Also, such continuous and precise monitoring of blood density would be extremely useful in the diagnosis and treatment of trauma patients and any other malady involving rapid or profound blood loss or physiologic fluid shifts. See device 100.

Morbid obesity would likely make this device unusable as it would increase signal attenuation and would therefore make readings very difficult. There would be a marked decrease in the signal-to-noise ratio in patients with thick layers of adipose tissue. When working within normal physiologic blood pressure ranges, period calibration of the device using a conventional sphygmomanometer would solve the problem of accuracy in most situations where body habitus interferes with the normal function of the device. However, in the non-obese patient, even in cases where calibration is not possible, such as a profound hypotension or cardiac arrest, accurate readings may be attainable with the device.

Another challenge would be the design of a stable transducer-to-skin interface acoustic conductive medium. The interface must remain fixed in position for a number of hours. It must be comfortable to the patient, and provide reliable ultrasound conduction.

In summary, the vascular application of the device would be capable of accurately and continuously measuring arterial and venous blood pressures, pulse rate, blood density, and blood flow velocity, and it would be capable of calculating peripheral vascular resistance. When the venous system and interstitial space are monitored, the state of hydration can be assessed. When applied to the chest, then pulmonary, central venous, pleural space and cardiac monitoring may also be possible. The device may have many other uses, including the measurement of compartment, ocular, intra-abdominal, intracranial, and specific organ pressures. In addition, the device could be mated to other

more conventional equipment, e.g., measuring oximetry and temperature.

Device 100

Another version of the new and improved noninvasive blood density measurement device 100 is a simpler form of device 10 of the invention for the purpose of supplying in vivo blood density information for medical monitoring and research. The function of device 100 is the same as that of device 10, except that ultra-precision is not required. As with device 10, the goal with device 100 is the noninvasive in vivo measurement of blood density. However, it will not have the necessary precision to detect the minute density fluctuations which represent pulse pressure. Therefore the device requires somewhat less sophistication.

The primary goal of monitoring blood density is to detect fluid shifts within the body. Also, because hematocrit is the main contributor to the density of whole blood, then both device 10 and device 100 are continuous noninvasive hematocrit monitors. They could, therefore, both be used to monitor multiple parameters in critically ill or injured patients or be used to spot check patients for blood disorders.

Within the practice of nephrology, the monitoring of blood density during dialysis is well known to be important as it is used to predict and preempt sudden onset of hypotension. However, the relevance of blood density values and trends as they relate to the status of critically ill or injured and potentially unstable "critical" patients is not well known. Under the current state of the art in blood density measurement, comprehensive research on the clinical relevance of blood density is not possible. Device 100 is needed so that such clinical relevance, or lack thereof, can be discovered.

Currently the state of the art in blood density measurement is practiced using only extracorporeal methods. One method uses frequent blood sampling and subsequent laboratory analysis. Another less precise method uses a continuous optical device during hemodialysis which clamps onto the dialysis tubing and measures the concentration of the extracorporeal blood. Continuous blood density monitoring is currently unavailable for patients who are not undergoing hemodialysis. Frequent blood sampling, although precise,

is labor intensive, expensive, and impractical. There is a need for a tool such as device 100 which measures blood density conveniently, continuously, noninvasively, and in vivo. In addition, device 100 may be capable of providing continuous data relating to arterial and venous blood flow velocities, extravascular fluid stores, and analogs of vascular resistance and cardiac output.

This description of device 100 is also an addendum to the description of device 10. Most of the technical aspects of device 10 are identical to that of device 100, and therefore, the text of this description applies fully to that of device 10. FIGS. 4 and 5 illustrate one possible form of device 100 and device 10 of the invention. Although the basic function of the two devices is almost identical, the goals of precision and clinical application differ and would dictate certain technical variations.

Physiological Basis for Measurement of Blood Density in Critical Patients

During severe physiological stresses there are significant alterations in blood density as the blood becomes more concentrated or more dilute. These alterations occur as a result of transcompartmental fluid shifts that, in turn, are caused by physiologic compensations in for form of osmotic or hydrostatic effects. Significant fluid shifts--and thus dynamic changes in blood density--occur during shock from any cause including hemorrhage, sepsis, spinal cord injury, toxins, and cardiogenic causes. Less significant, but still noteworthy, are fluid shifts and blood density changes that occur during more ordinary clinical situations such as orthostasis (1), dehydration and rehydration, various pharmacological therapies, and weightlessness. Therefore, the measurement of blood density and its trends may thus become an important tool for ruling out certain causes of syncope and dizziness.

When the condition of low intravascular volume or pressure occurs, physiologic compensations are triggered in an attempt to maintain blood volume and thereby blood flow to the vital organs. Under these conditions the vascular system osmotically draws fluid into the blood from the extravascular space. This results in dilution of the blood and a drop in blood density (hemodilution). For example, hemorrhage results in

rapid fluid movement from the extravascular to the intravascular space and thereby causes hemodilution. (2) The vascular system is, in effect, "borrowing" fluid from the tissues in order to preserve blood volume and flow.

5 Similarly, an infusion of IV fluids will initially cause hemodilution and a drop in blood density. However, the dilution from IV fluids will not persist if the blood volume and osmotic and hydrostatic pressures remain adequate, because the fluid will eventually migrate from the blood to the extravascular space (if it is not first lost through renal excretion or other insensible losses). The vascular system thus gives back fluid that it may have once "borrowed" from the tissues, and the blood density or concentration will
10 drift back toward a more normal range.

Certain catastrophic vascular effects are triggered by prolonged or severe shock, sepsis, burns, crush injuries, and toxins. The result of these effects is capillary damage and leak. This leaking causes fluid to shift from the blood to the extravascular space, and thus results in a blood volume decrease accompanied by a blood density increase (hemoconcentration). Since diuretics and blood transfusions effectively cause
15 hemoconcentration, and IV fluids cause hemodilution, then device 100 could also become a useful tool in the monitoring and management these types of therapeutic interventions.

The clinical course for severely ill or injured patients is typically very dynamic. As the disease process takes its course, the physician then responds with
20 aggressive treatment using surgical techniques, vasoactive drugs, IV fluids, and blood products. Multiple events take place in rapid sequence, and each has its own effect upon blood density. In such dynamic situations, the interpretation of blood density values and trends would be complex. Clinical studies must be done in order to define the parameters for use of device 100.

25 Since blood density is already known to be an important indicator to observe during hemodialysis, it is reasonable to assume that there is also a relationship between the clinical course experienced by the critical patient and the magnitude and rapidity of the changes in blood density. It is likewise reasonable to assume that there are physiological

limits to blood density and that high and low extremes are not compatible with life. Therefore, blood density monitoring may be as important in the management of any critical patient as it is in the management of a hemodialysis patient.

5 The density of blood is determined by multiple factors, the most influential of which are the hematocrit and serum protein level. Other determining factors are pressure, temperatures, and dissolved sugars, salts, and gases. Since device 100 is not designed for ultra-precision as is device 10, the blood pressure contribution to density values will be negligible. For purposes of simplicity during earthbound research, pressure would be assumed to be fixed at one atmosphere. Also, since it has a significant effect upon density, a
10 calibration or correction for temperature must be accomplished.

The device would be useful in any medical setting where care is provided for critical patients. This would include such settings as emergency departments, intensive care units, surgical or post-operative areas, burn units, hemodialysis units, military mash units, and battlefield settings. It would also be useful in aerospace research settings. There are
15 significant transcompartmental fluid shifts that occur in the zero gravity environment. (3, 4)

In order to ultimately find its niche among the tools of clinical medicine, the device must initially serve the purpose of research tool. To date it appears that there has been very little research done and in the area of blood density and its correlation to the clinical status of critical patients. However, the few studies that have surfaced do seem to
20 indicate that such monitoring would probably be useful, provided that convenient method of measurement is available. There is currently no existing device for monitoring blood density in vivo and noninvasively on a continuous basis.

Device Function--Another Version

25 The function of device 100 depends upon in vivo sound speed measurement within blood. Its basic function is identical to that of device 10, but with less required precision. Acoustic transit time (time-of-flight) is measured using the "pitch-catch" method between proximal and distal transducers in both upstream and downstream directions simultaneously. Another option would to replace one transducer with a reflector. The

remaining transducer would act as both sender and receiver, and would clock total time-of-flight. Either device would be applied to the body wherever the best arterial and venous signal can be obtained. These time-of-flight measurements would be then be used to calculate acoustic velocities upstream and downstream. Readings would be taken from both
5 arterial and venous blood and then the data from each or averaged data from both would be fed into a microprocessor where it would be converted to blood density and flow values.

When using the time-of-flight method to obtain blood density readings, the effect of blood flow velocity upon time-of-flight must be negated. Although the condition of "static" blood is not possible under most in vivo circumstances, a correction can be made
10 for the effect of flow upon the measurements. BY using the upstream and downstream velocity values, a calculated "static equivalent" acoustic velocity can be obtained. The effect of flow is thus cancelled out mathematically by dividing the sum of the upstream and downstream acoustic velocities by two. The result is the acoustic velocity equivalent as if it were measured within static blood.

15 In practical terms it may be very difficult to separate the arterial and venous signals since, in the circulatory system; the arteries and veins are usually paired and located in close proximity to one another. The signal would thus be essentially already averaged along with the portion of the signal attributable to capillary blood.

Based upon the UNESCO equation for sound speed in water, this resulting
20 "static equivalent" acoustic velocity value has a direct mathematical correlation with blood density as discussed in the description of device 10. The UNESCO equation--which was developed for the study of sound speed in seawater--can be used to substantiate this method, since blood, like seawater, is simply water with certain substances in solution or suspension.

Blood flow velocity would be calculated by subtracting the upstream from
25 the downstream acoustic velocity and dividing by 2. Both venous and arterial flow velocities can be calculated in this fashion. This time-of-flight method of blood flow velocity determination differs from that of the Doppler method, since its operation depends upon sound-speed measurements and not phase-shift data.

Since the device senses blood flow in both directions, it would be able to differentiate venous from arterial flow. In terms of practical function, the fact that it is sensing blood flow assures that the device is indeed reading the density within intravascular fluid and not within extravascular fluid.

5 Interestingly, device 100 may also be capable of providing a measurement of acoustic velocity within the extravascular space. This would be useful in monitoring the body's stores of extravascular fluid, i.e., hydration status. Sound speed should change proportionately with the fluid "saturation" of the extravascular tissue.

10 Another method of assessing the dynamic status of the extravascular fluid would be to monitor the difference between arterial and venous blood density values. This may present a challenge if the arterial venous blood density measurements can not be distinguished one from the other, but the data obtained from this method would contain relevant information relating to the movement of fluid into and out of the extravascular space. For example, when the arterial blood density is found to be higher than the venous
15 blood density, the conclusion might be made that physiologic compensation is underway and that fluid is moving from the extravascular space into the blood, such as might be seen during blood loss. This differential arterial-venous blood density value would probably be detectable prior to any significant alteration in whole blood density and would serve as a very sensitive and contemporaneous real time gauge of intravascular-extravascular fluid
20 movement.

 By applying existing state of the art methods of measure, this device could also sense pulse-wave velocity by clocking the pulse-wave as it passes by the two transducers. Pulse-wave velocity is the speed of the arterial pressure wave as it propagates from the heart to the peripheral tissues. It can be used to estimate cardiac output when
25 adjusted for patient age. An analog of cardiac output could most likely be calculated from mean arterial blood flow and pulse-wave velocity. An analog of vascular resistance could also theoretically be calculated if mean arterial and venous pressures and blood flow are known. The actual analog values of cardiac output and vascular resistance obtained in this manner would be useful only for trending. (5)

Another already existing method of measuring pulse-wave velocity involves mating the device with an electrocardiogram (EKG) electrode and measuring the time from the QRS impulse to the arrival of the pulse-wave at the device. Also, contour analysis of the pulse pressure wave is a method currently being used to estimate cardiac output. These
5 methods seem to be gaining some validity within the research literature as being reliable for trend monitoring of cardiac output. (6)

Like device 10, device 100 would digitally display the instantaneous arterial and venous blood density and blood flow velocities, the analogs of cardiac output and vascular resistance, and their trend lines as well as rate of change.

10 The acoustic frequency range to be used would vary with the desired separation distance between transducers. Both are yet to be determined. As with device 10, the electronics required would include a device driver 20 that controls each transducer by triggering impulses at a rate between 10 Hz and 100 Hz. Each transducer would act as both
15 sender and receiver and would be connected to a signal processing computers 22 that would note time-of-flight for each impulse and then calculate the dimensions and location of the vessels and arterial and venous blood density and flow velocities. The receivers would also send pulse-wave velocity data to the computers 22 for signal processing and calculation of
20 vascular resistance and cardiac output analogs. Scanners 24 would collect data from the computers and transmit it to the display 26 and printer 28. A power source 50 would be connected to all components.

25 The housing for the transducers (FIG. 4), which would most likely be constructed from medical grade epoxy or silastic, would fix the distance between the two transducers and set the proper angle to the skin in order to create the most optimal signal for processing. The requirements for housing style might differ depending upon the anatomic location to be monitored. For use on the arm, for example, the housing must be as flat as is
practical and secured in some fashion. Testing must yet be performed in order to find the most optimal transducer separation, angle, and frequencies, as well as the best type of acoustic conductive medium, arm band style, etc.

There would possibly be a need to tune (power, transducer wavelength, transducer triggering frequency, and beam spread or scatter) the ultrasound beam in such a way as to effectively maximize the intravascular acoustic travel distance (the distance that the sound wave actually travels within the blood vessel on its path to the receiving
5 transducer). Such tuning might take the form of a transducer array possibly requiring the use of more than one frequency.

As with device 10, and for the sake of precision, the operational goal of device 100 is for the sending transducer to create a shock wave "click," and to clock its transit time within the blood to the receiving transducer. Since sound waves travel in all
10 directions from their point of origin, it would be difficult to know the exact length of the intravascular sound wave path. However, fixing the transducer separation by using rigid housing and using a technique such as Time-Reversal Mirrors should define the wave path well enough to accomplish the desired level of precision. Maximizing and closely defining the length of the sound wave path would be a crucial step for the accurate determination of
15 intravascular sound speed. Detection and timing of the first arrival wave would indicate the transit time for the most direct path between transducers. Since sound speed is higher in blood than in the surrounding tissues, then this first arrival wave would be considered to have passed through blood.

Therefore, both sending and receiving transducers may need to be tuned
20 (focused or defocused) to maximize the path within the blood. Tuning may need to be individualized for each patient and for each anatomic location. The induced intravascular "click" would emanate in all directions from its point of origin within the vessel. Much of the resulting wave energy would then travel through the blood (arteries, veins, and capillaries) and be detected by the receiving transducer. The effect of this tuned shock-wave
25 technique would be to maximize the intravascular travel distance of the acoustic wave. It would also improve signal-to-noise ratio for the time-of-flight impulse.

The remainder of the wave energy would reflect and/or scatter and would ultimately also be detected by the receivers. The data collected from the reflections would reveal the status of the extravascular fluid balance, and would also be used to determine the

size and location and the selected vessel. This data would in turn be fed into the signal processors and could be used to guide the tuning of the ultrasound beam. By applying signal processing techniques, the true intravascular signal would be separated from the signals resulting from reflections and scatter.

5 For device 10 this technique of tuned input and detection would likewise be applied for the purpose of signal enhancement and precision, even though input frequencies and transducer types might differ.

 The type of transducer to be used in device 100 is also yet to be determined. Common piezoceramic transducers may work well, but in order to assure the proper brevity
10 of the input impulse "click", other types of transducers may be required, including but not limited to, polymer, piezo, laser, infrared, radio frequency, Fiber-Bragg laser receivers, and hybrid transducers.

Device Function--Still Another Version of Device 100

 Although sound velocity measurements would ideally be made
15 longitudinally through a vessel, in practical terms this might be very difficult to do non-invasively. Sound waves prefer to travel along straight paths. Therefore the most practical body location chosen may involve the acoustic wave crossing a vessel perpendicularly. If high enough frequencies are used (1 to 20 MHz), then the desired precision might still be accomplished. The vessels adjacent to the external ear may be amendable to such a
20 monitoring method. Other locations such as the perioral and post-auricular arteries might also be used.

 A specific example is the superficial temporal vessels, located just anterior to the tragus of the external ear. In this case the vessel may be monitored by placing the sending transducer against the anterior wall of the external ear canal just behind the tragus.
25 The receiving transducer would then be placed against the skin anterior and superior to the tragus, positioning the vessel between the two transducers. The sender would emit its impulse directly towards the receiver across the vessel. Continuous time-of-flight measurements would be continuously corrected for temperature changes and converted into

blood density values. If the separation between transducers can be maximized, and if frequencies used are high enough (500 KHz to 100 MHz), then desired precision might be accomplished. See FIG. 5. Temperature correction may be accomplished by incorporating a temperature probe into the device just adjacent to the transducer or with the use of a dual-
5 mode oscillator crystal, which has the characteristic of self-temperature-sensing.

In order to maintain accuracy of sound velocity readings and thus blood density measurements, the device would incorporate a temperature probe and also electronics for continuously monitoring the mechanical separation between transducers. Since movements such as chewing and talking may change the separation of the
10 transducers, the device could instantaneously adjust for the change and recalculate sound speed based upon the new distance. In all practicality, the separation between the transducers or transducer and reflector should be fixed by using a rigid housing or include a monitoring mechanism for measuring changes in the separation distance between the transducers or reflector. This would apply to both device 10 and device 100. Also, with
15 either device, it may be relatively easy to incorporate an oximeter. The application of a small array at the receiver may provide vessel diameter information and thus an analog of pulse pressure.

In summary, device 100 may provide the following continuous data from a stable platform overlying a vessel near the ear: [0109] 1. Blood density [0110] 2.
20 Temperature [0111] 3. Oximetry [0112] 4. Pulse rate [0113] 5. Pulse pressure analog

Another device 120 of the invention is an intravascular catheter that contains sensors for in situ measurements of multiple whole blood physiologic and hemodynamic parameters. It would be a unique and useful diagnostic tool that would facilitate rapid decision-making and optimization of medical management and resuscitation of patients
25 suffering from the most challenging and life-threatening medical conditions. The instantaneous monitoring by the application of the invention would provide a means by which to immediately assess the effectiveness of fluid and blood administration as well as pharmaceutical or surgical interventions. Currently there exists a significant lag-time between the initial recognition of a problem, such as sudden hypotension, and the obtaining

of lab results that may or may not confirm clinical suspicions of the problem cause(s).

5 The physiologic and hemodynamic data obtained with the use of device 120 would allow the clinician to more quickly differentiate the causes of hypotension from any cause or combination of causes. Intravascular monitoring would provide information useful
10 in determining the cause of shock, e.g., sepsis, blood loss, and autonomic malfunction such as that caused by spinal cord injury. For the clinician, knowing the level of vascular resistance and vascular fullness would also improve the ability not only to differentiate the causes of abnormal vital signs, but also to determine the best course of treatment in each circumstance. Such treatment may include infusion of saline, blood, both saline and blood,
15 or pressor medications; the performance of specific surgical inventions, appropriate airway management, or fracture stabilization; or, in some cases, simply the administration of pain medications. Continuous monitoring of this broad range of physiologic and hemodynamic parameters would also provide immediate feedback on the effectiveness of the above interventions.

15 Primarily, the device is intended for peripheral vascular (venous or arterial) use in prehospital, emergency, surgical, post-surgical, burn unit, and ICU environments. The invention may be useful in any other medical patient or research environment where it might be desirable to measure and/or trend the above stated physiologic and hemodynamic values. These include but are not limited to military, aerospace, and subsurface marine
20 environments. Other clinical or research applications may include the trending of any biologic fluid within any body space, whether it be peripheral or central vascular or fluid filled body cavity. Examples of confined body cavities would include the urinary bladder, gallbladder, intra-abdominal, brain ventricles or spinal fluid. The device could possibly be used to monitor the status of the above parameters within extremity fascial compartments or
25 post-op plastic surgery skin flaps. It may be especially useful to also monitor pH or lactic acid level within a compartment where there is potential muscle necrosis to determine the need for and improve the timeliness of rapid surgical intervention. In addition to vascular or compartment pressure readings, the catheter could potentially be used to measure the pressure in gas-filled structures such as pulmonary airways and bowel lumen. It would be

useful in the clinician's office for routine on-the-spot laboratory analysis.

When the catheter device is placed intraarterially, systolic, diastolic and mean blood pressures, pulse pressure, pulse rate, and the incorporated physiologic parameters would be displayed continuously. This type of information is routinely used in evaluating critical care patients. In addition, local blood flow velocity and calculated local vascular resistance (LVR) would also be displayed continuously. Ideally the clinician would want to know the level of total systemic vascular resistance (SVR) which relates to total sympathetic vascular tone. But SVR cannot be obtained from a peripheral catheter. SVR, which is commonly calculated in physiology research, is an important factor in determining the workload of the heart and how the vascular system is acclimating to various insults, such as trauma or infection. Although one cannot determine cardiac workload from LVR, it is theorized that LVR trends would parallel SVR and therefore be useful for observing changes in cardiac workload and sympathetic tone. LVR cannot be measured by any blood test and is not currently being measured for critical care resuscitation purposes in any clinical realm.

Since blood density is being precisely monitored, vascular volume can be determined by injecting a small volume of IV fluid (saline) and observing the change in blood density. Vascular volume is then calculated by the common dilution formula, $BV = V_i \cdot \rho_i / \Delta \rho$, where BV is blood volume, V_i is the volume of saline injected, ρ_i is blood density and $\Delta \rho$ is the change in blood density observed as a result of the given fluid injection. Cardiac output can therefore also be calculated by the formula $CO = BV / T$, where CO is cardiac output, BV is the above calculated blood volume, and T is the time that it takes for the change in blood density to occur after administering a given volume of saline (the time that it takes for the heart to circulate the saline throughout the vascular system one time). Previously, information about vascular tone, vascular volume, and cardiac output has been confined to the realm of medical research and unavailable for routine use in clinical medicine.

Venous monitoring with the present invention would yield the same valuable blood density data as with arterial monitoring. Device 120 would also supply venous

5 physiologic and hemodynamic parameters. In some circumstances, it may be valuable to perform trending of venous physiologic data and hemodynamic data. Venous placement of the catheter would not require special expertise and could be initiated by paramedics in the prehospital environment. Like the arterial catheter, the venous catheter would yield useful data continuously.

Standard arterial pressure monitors, because of the hydraulic transducer, can be clumsy due to the tubing and pressure bag. They require time consuming calibration. They do not provide information on blood concentration, blood flow velocity, temperature, blood gases, pH, oximetry or lactic acid level. Device 120's pressure sensor could be quickly calibrated to atmospheric pressure prior to insertion and thereafter would continuously self-calibrate for temperature changes. It would not require calibration for blood concentration or blood flow readings.

A. Blood Concentration and Hematocrit Measurement by Acoustic Methods:

15 It is known that sound speed in whole blood is determined by total protein concentration.^{sup.11}, the concentration of ions, and the temperature.^{sup.12}. The majority of protein in whole blood resides within the hemoglobin of the red blood cells (RBC's).^{sup.10}, 11. Therefore, not only can sound speed be used to very precisely measure blood density, it can also be used to measure the relative number and hemoglobin content of the RBC's.

20 The function of the device 120's blood concentration monitor depends upon the measurement of several properties of whole blood acoustic propagation. These include ultrasound velocity, attenuation, and backscatter measurements.

1) Ultrasound Velocity: By measuring high frequency sound wave time-of-flight, velocity can be calculated very precisely.^{sup.9}. Therefore, sound velocity in whole blood can be used to accurately measure and trend blood density..^{sup.11, 12}

25 The speed of sound in any liquid is also influenced by temperature.^{sup.13}, 16. Therefore, if blood density is to be measured by the sound-speed technique, then it is imperative that temperature be taken into account. The primary determining factors for

blood density are the total blood protein content and salinity. Within the human physiologic range, however, changes in salinity do not significantly affect sound speed.^{sup.11, 13.}

Whole blood consists of particles (cells, platelets, and insoluble plasma proteins) suspended within a water solution containing primarily salt ions, sugar molecules, and soluble proteins. The particles in suspension do not necessarily possess the same density as the solution itself. Therefore, the velocity of sound across a sample of whole blood is determined by the sum of the velocities of the blood components within the path of the sound wave.^{sup.11}

Most blood protein resides within the red blood cells in the form of the iron containing protein hemoglobin. As a result, changes in sound velocity are directly proportional to changes in the concentration of hemoglobin within the sound wave path.^{sup.10, 11} Velocity measurement is, therefore, an acceptable method of total hemoglobin estimation.^{sup.7, 11, 12} Since the hemoglobin (Hgb) resides within the red blood cells (RBC's), then sound speed is also proportional to hematocrit (Hct), the percentage of whole blood consisting of RBC's.^{sup.10} For the purposes of the design of device 120, Hgb and Hct are so closely linked in terms of their relationship to sound speed that they will be considered one and the same and will be referred to heretofore as H/H.

When serum protein levels are unusually high or low, however, an error in H/H estimation may be produced in the sound speed method.^{sup.11} For example, a high serum protein level would result in overestimation of H/H, and a low serum protein level would result in underestimation of H/H. Nevertheless, methods exist for very precise measurement of sound speed.^{sup.9} and, within the normal human range of H/H.^{sup.11}, sound speed has high overall correlation to H/H. In the very low H/H range, however, anomalies in serum protein level produce proportionately larger errors in H/H measurement by the sound speed method. Therefore, in order to create a device that is accurate in all H/H ranges, it would be desirable to primarily use sound speed for H/H measurement and, to correct the results obtained in the lower range of H/H.

Others have shown that sound speed.^{sup.11}, sound attenuation.^{sup.15}, and

backscatter amplitude.sup.14, 15 each have their own individual relationship to H/H within certain ranges of H/H. Because each individual parameter seems to possess a different level of accuracy within different ranges of H/H, it can be theorized that each parameter might be used to correct the measurement results of the other parameters. In the work for the above
5 referenced patent, averaging of the parameters was used to achieve modest improvement in the accuracy of H/H measurement. It is an object of the current invention to enhance device accuracy by developing specific mathematical algorithms that better describe the influence of each parameter upon the instrument's accuracy.

2) The Relationship Between the Accuracy of the Sound Speed Measurement
10 of H/H and the Serum Protein Content:

An in vitro study of random anonymous whole blood samples (n=30) to determine the correlation of hematocrit with sound speed, correlation was found to be high (R=0.93) in the overall population. Best fit was performed in this population of whole blood samples, and it was found by regression analysis that the relationship between sound speed
15 c and Hct can be described as follows: $Hct=1.0135(c-1520)+8.8874$ By further regression analysis (R=0.85), it was found that the percent of error in Hct measurement produced by variations in serum protein level (SP) can be described by the following equation: $\% \text{ error} = -30.354 \ln^*(HCT/SP)+47.47$

3) Continuous Precision Sound Speed Measurement:

20 The intravascular device would continuously measure acoustic transit times in order to calculate sound speed in whole blood, and thereby measure whole blood density. By continuously measuring transit times and minute shifts in transit times in rapid sequence (10 to 1000 Hz), such measurements, if made with precision, would result in accurate, reliable, and continuous blood density and H/H data. FIG. 1 illustrates the sound speed
25 sensor as a single transducer-reflector pair with the reflector fixed at a specific distance, e.g., 5 mm. The transducer acts as both sender and receiver and is connected to a power source, recognition and analysis hardware and software, display, and printer.

The particular hardware that runs the sound speed sensor will depend upon

available high fidelity equipment. An example of available equipment is that developed by Dr. Craig Hartley PhD, which is capable of detecting transit time of an ultrasound wave by detection of 1.degree. of phase change.^{sup.9} Using a 20 MHz ultrasound frequency, the method has been shown to be capable of detecting a 139 psec increment change in the time of sound wave arrival. Assuming average sound velocity in the human body to be 1540 m/s, the time increment of 139 psec time increment translates to a velocity increment of 0.0329 m/s between fixed transducers. From the above referenced NPC in vitro study, it was discovered that a sound velocity increment of 0.0329 m/s translates into a hematocrit increment of 0.0333%. This level of precision would be excessive for the purposes of blood density measurement. However, such precision could potentially be used in making pressure measurements (see the below description of a novel method of pressure measurement). Sound speed changes that occur as a result of pressure changes are extremely minute, and would not alter measurements done for the purpose of hematocrit monitoring.

Temperature has a significant effect upon sound speed in liquid.^{sup.13}

Device 120 will include a probe which will allow for continuous calibration for temperature changes. A change in temperature of 1.degree. Celsius produces an error of 7.5 nanoseconds in time-of-flight across a sound wave path 10 millimeters in length. Therefore the conceptualized multiparameter catheter must have appropriate temperature compensation. This will most likely take the form of an off-the-shelf precision temperature probe embedded in the catheter tip, such as a thermistor or other miniature sensor. An alternative and unique method of precision temperature measurement utilizes an ultrasound technique called Dual-mode Oscillation. The actual method used will depend upon its ease of incorporation into the catheter and its accuracy and precision. Measurement of the temperature to within ± 0.1 .degree. Celsius would probably be adequate for purposes of measuring H/H. It would provide a resolution of $\pm 0.28\%$ in hematocrit determination.

4) Attenuation: Whole blood protein, whether contained within cells or suspended in the plasma, absorbs sound. Therefore, as a sound wave travels through a sample of whole blood, the amplitude of the wave attenuates over a given distance depending upon the quantity of protein through which it passes. Most blood protein resides

within the hemoglobin molecule. Cell membranes also have significant effect upon attenuation because of their sound absorption and sound wave scattering effect.^{sup.15}. Device accuracy for Hct estimation, therefore, may be enhanced by the mathematical incorporation of attenuation values. This can be accomplished by measuring the amplitude
5 of the received wave at the sound speed measurement transducer.

5) Doppler signal backscatter measurement. A significant proportion of ultrasound wave energy reflects off of cell membranes. The Doppler method applies this physical characteristic of sound to detect movement (flow) of whole blood within vessels, utilizing a change in pitch of the sound reflected off of the cells. When the cells are struck
10 by the sound wave, they reflect and scatter the sound. The amplitude of the reflected Doppler signal is related to the number of cells within the sound field that have reflected the sound waves back to the transducer. Although the Doppler backscatter method may not be as amenable to precision measurement as sound speed, the backscatter coefficient (BSC)
15 may be more representative of the actual number of cells present within the sound path at low Hct levels of <10%.^{sup.14}. Interestingly, it is at such very low Hct levels that sound speed is least accurate. Therefore, measurement of backscatter level may provide a way to mathematically correct for inherent sound speed method errors in H/H estimation that occur secondary to anomalous serum protein levels when hematocrit is <10%. This can be
accomplished using the same transducer as for sound speed measurement.

20 B. Arterial Blood Pressure Measurement

The parameters of systolic, diastolic, and mean blood pressure (and also venous pressure) could be incorporated into device 120 using several methods. Two existing technologies that could easily be incorporated into the catheter are:

1) The most common method currently employed in clinical practice, the
25 traditional hydraulic pressure line with ex-vivo transducer, could easily be used because the catheter will be designed with a port. In this case no special adaptations would have to be made to the catheter.

2) A second type of intravascular pressure monitor involves a miniature solid

state transducer within the tip of the catheter. This type of sensor is used for cardiac catheterizations and vascular research. The intravascular transducer would have the advantage of compactness with no need for the cumbersome hydraulic line and ex-vivo transducer. It could be calibrated prior to insertion. The disadvantage of the intravascular pressure transducer is the fact that position (if it is above or below the level of the heart) will affect the accuracy of the readings. But if the patient remains supine, however, the effect is minimal, producing only about a 2 mmHg change in pressure for every inch of elevation change. Position would not change pulse pressure readings.

3) Two novel methods for blood pressure measurement by sound speed method are:

a) As discussed above in the section on blood density measurement, a novel method for pulse pressure measurement involves precise continuous sound speed measurement. Theoretically, if changes in sound speed could be made with extreme precision (within incremental resolution of less than 2-4 picoseconds), then pulse pressure could be monitored. Due to calibration issues, systolic and diastolic pressures could probably not be measured. According to the UNESCO equation for sound speed in sea water^{sup.13}, there are minute changes in sound speed due to pressure changes. The advantage to using this method is that the data could be obtained using the same sound speed detection transducer(s) used for H/H measurement. A disadvantage to this method is the difficulty in obtaining the required picoseconds precision. Even if such precision could be obtained, it would be a very difficult matter to achieve accurate systolic and diastolic pressure measurements with this technique because of the fact that calibration to zero would be very difficult since the base-line would drift with changes in hematocrit, temperature, salinity, and changes in the elevation of the catheter-tip versus the level of the heart.

The UNESCO equation describes the relationship between acoustic wave velocity and pressure in water. The equation also takes into account other factors that contribute to alterations in sound speed, such as the salinity and the temperature. Although fluids (blood included) are considered incompressible, the equation shows that there should be minute but measurable changes in velocity associated with changes in pressure, even

within the human blood pressure range of 0 to 300 mmHg.

To form theoretical support for the sound speed method of pulse pressure measurement, the space between two hypothetical transducers was assumed to be 2 cm (or 1 cm. between one transducer and a reflector). The UNESCO equation was then used to
5 calculate acoustic velocity at pressure increments of 1 mmHg assuming constant fluid temperature at 37.degree. Celsius, constant salinity at 9 ppm, and variable pressure is expressed in kPa. Calculations using the formula $V=D/T$ indicate that, in order for the device to have precision to within 1 mmHg, it must be capable of detecting shifts in transit time of roughly 2-4 picoseconds. Trending of the pressure within $\pm .5$ mmHg could be
10 achieved by the detection of shifts of approximately 20 picoseconds across a sound path of 2 cm.

The method can be accomplished using either two transducers or one transducer with a reflector. When using two transducers, one must account for blood flow velocity (which ranges from approximately 0.2-1.0 m/s) and its effect upon time-of-flight
15 between the transducers. The preferable method, therefore, would be to utilize a single transducer-reflector pair. This method would have the advantage of automatically eliminating the effect of flow and of doubling the length of the flight path (and thus doubling precision) without increasing the length of catheter.

According to the UNESCO equation, there is a 19.68 picoseconds change in
20 the transit time across a 2 centimeter distance for every 10-mmHg change in pressure. The variability of the above mentioned physiologic values, however, may result in a much larger drift in transit times of several hundred nanoseconds of. According to the UNESCO equation, when salinity is fixed at 9 ppm, a change in body temperature of 1 degree Celsius would alter transit time by about 15 nanoseconds (a scale that is roughly three magnitudes
25 greater than transit time shifts resulting from incremental changes in pressure). Similarly, with temperature fixed at 37.degree. Celsius, alterations in salinity of only 0.1 ppm would result in a change in transit time of about 0.85 nanoseconds. These values were calculated using velocity data obtained from the UNESCO equation at the National Physical Laboratories (NPL) interactive website.^{sup.16} and using the previously noted common

equation, $V=D/T$. Such large-scale changes in blood density would of course occur over a period of minutes to hours and not milliseconds and therefore would not affect momentary pulse-pressure readings.

5 The best method for ultrasound (US) pulse delivery and detection must be determined. Potential devices would include conventional high frequency ceramic piezoelectric US transducers, RF (radio frequency) and Laser Optical-acoustic US transducers, polymer piezoelectric US transducers, IR (infrared) receivers, and Fiber Bragg Grating (FBG) Laser receivers, not excluding other existing and/or future transducers or sensors which are found to be applicable. All of these devices are referred to herein as
10 "transducers" and/or "sensors." The frequency and amplitude chosen for the input signal, as well as the mechanism of its delivery, will depend upon requirements for patient safety and requirements to achieve proper blood penetration and conduction of the acoustic wave.

This device will likely require a frequency greater than 20 MHz for precision. In reality the attenuation of the signal at the higher frequencies may prohibit
15 achievement of the desired level of resolution. Calculations using the UNESCO equation show that, even at a frequency of 100 MHz and a 2 cm transducer separation, the best resolution that can be achieved using current technology is only $\pm .15$ mmHg. At frequencies higher than 100 MHz, attenuation would most likely prevent practical transducer/reflector separation of more than a centimeter. However, at 20 Mhz frequency,
20 resolution would be more than adequate for trending of blood density and blood flow. Future technologies could potentially arise that would make this method usable for systolic and diastolic blood pressure measurement, and not just for pulse pressure measurement.

Time-of-flight measurement would be made by the most precise method available. This could include such instrumentation as is available for standard
25 sonomicrometry equipment. Phase-shift detection could be the most optimal signal processing technique because of its extreme precision. A sonomicrometer technique developed by Dr. Craig J. Hartley can detect changes in phase of as small as 1 degree of arc.⁹ At 20 MHz this sonomicrometer can detect movement in a mouse carotid artery as minute as 1 micron.^{ref} This translates to a time resolution of 139 picoseconds.

b) Another novel sound speed method that could be used involves the incorporation into the catheter of a small chamber filled with an inert gas. As with the above H/H measurement by sound speed method, sound speed could be measured either by using the two-transducer (pitch catch) technique or utilizing the preferred transducer-reflector pair. Transit time measurements must be performed continuously at a rate of at least 30 cycles per second in order to detect all phases of systole and diastole. The zero pressure could be easily calibrated to atmospheric pressure prior to vascular insertion. Continuous temperature calibration would also be required, but is already being done continuously for the H/H monitor. This method could be more accurate and precise than solid state pressure sensors.

An advantage to using this method may stem from the fact that the sound speed analysis equipment is already incorporated into the system for H/H measurement. Applying this technique would require the addition of another transducer and reflector pair with the same electronics analyzing the signal. Potential disadvantages to this acoustic chamber approach may be that the close proximity of the chamber walls could result in anomalous sound speed readings. A lower frequency (50-500 KHz) transducer would be required for this technique. A potential pitfall could be the difficulty of developing a low frequency transducer that would be physically small enough to fit onto the catheter. Also, gas leakage could potentially limit the useful life of the monitor. If the gas did leak, it would not pose a danger to the patient because the volume of gas would so minute that it would immediately absorb into the blood. The type of gas utilized has yet to be determined and, except for safety reasons, would not be limited to any particular gas. Since instrument precision increases with frequency, the choice of gas used in this device would be dependent upon its ability to conduct higher acoustic frequencies. The particular frequency and gas characteristics are yet to be determined. The gas, of course, must not possess any properties that are toxic to the patient or that would deteriorate the plastic of the catheter itself.

C. Blood Flow Velocity Measurement:

The arterial blood flow velocity parameter would be measured by use of a

standard Doppler probe mounted at or near the tip of the catheter. The best mount position would be chosen in order to detect flow in a location where flow is unaffected by the presence of the catheter itself. It may be possible to obtain Doppler flow values using the same transducer as is used for the blood concentration measurement. The blood flow velocity measurement could be displayed continuously and it would be used to continuously calculate, display, and trend local vascular resistance or local vascular tone.

D. Calculation of Local Vascular Resistance (LVR):

It must be understood that by placing the device 120 multiparameter catheter into a peripheral vessel, total systemic vascular resistance (SVR) can not be obtained. SVR can only be accomplished by monitoring a central vessel. However, for purposes of trending SVR, the monitoring of a peripheral artery could be useful. Trends of LVR may parallel trends for SVR. It is possible to calculate vascular resistance or its inverse, vascular conductance, by using the measured values of blood pressure, flow velocity, and vessel cross-sectional area CSA. The mathematical relationships are as follows: [0153]
 $F=V*CSA$.sub.expressed in ml/min [0154] $LVR=MAP/F$.sub.expressed in mmHg/(ml/min) [0155] $VC=F/MAP$.sub.expressed in (ml/min)/mmHg where F is local blood flow volume in the peripheral artery, V is local blood flow velocity, and CSA is the cross-sectional area of the cannulated vessel, PVR is the local vascular resistance within the cannulated vessel, MAP is mean arterial pressure, and VC is vascular conductance.

The monitoring of these particular vascular system parameters would give the clinician valuable information on the general state of vascular tone. For example, when blood pressure plummets, generally there is compensation by sympathetic and adrenergic mechanisms to increase PVR in order to maintain adequate blood pressure. This is certainly true in the case of hemorrhagic shock, in which case device 120 would show an increasing PVR coupled with a decreasing blood pressure and possibly a decrease in vessel CSA. Conversely, when the vascular volume is restored via blood product and/or IV fluid administration, device 120 would show a returning to normal of the PVR from high levels. In the case of spinal shock, however, device 120 would show that normal compensatory mechanisms are not occurring and that PVR is inappropriately low given the current state of

hypotension.

In reality, accurate intravascular measurement of vessel CSA may be cumbersome. It may be better to employ other techniques for vascular tone calculation. Device 120 could employ the use of pulse wave velocity (PWV) calculation to determine vascular tone. PWV in a region of an artery is mainly related to the elastic properties of the arterial wall of that region. Two techniques have been described by Harada et al that utilize one-point measurement of (PWV) and wave intensity (WI).sup.8. These two methods involve calculating 1) the characteristic impedance of an artery and 2) calculating the stiffness parameter. Interestingly, device 120 is already designed to measure the required input data for these equations including blood density, flow velocity, and pressure. Please see the reference article for the applicable equations.

E. Continuous Arterial Blood Gas Measurement:

An example of an intravascular blood gas monitor that could potentially be incorporated into device 120 is NeoTrend made by Diametrics Medical, Inc. NeoTrend was evaluated in a journal article entitled "Continuous Neonatal Blood Gas Monitoring Using a Multiparameter Intra-arterial Sensor;" by C. Morgan, S. J. Newell, D. A. Ducker, J. Hodgkinson, D. K. White, C. J. Morley, J. M. Church; "Arch Dis Child Fetal Neonatal Ed, March 1999;80:F93-F98

FIG. 6 is a view of the new and improved multiparameter intravascular catheter 110 vital sign measurement device of the invention showing a single sender/receiver transducer 112 paired with a reflector 114. Another potential configuration with two transducers, one sender and one receiver, is not illustrated since the receiver transducer would simply occupy the location of the reflector in FIG. 6. Included are diagrammatic representations of the incorporated probes for measuring sound speed and blood flow 112-114, temperature 116, blood pressure (BP) 118, arterial blood gases (ABG's) 20.

Each of the sensors 12, 14, 16, 18, and 20 illustrated in FIG. 6 is connected to hardware drivers 22, and a computer 24 that is programmed with recognition and analysis

software. Depending upon the function of the sensor 112, 116, 118, or 120, the computer software will differ as to each recognition and analysis computer 124 to receive the signal from its individual sensor 112, 116, 118, and 120, and convert the same into a measurement of blood concentration, hematocrit and/or hemoglobin, blood flow velocity, blood pressure, pulse rate, local vascular resistance, pH, pO₂, pCO₂ and any other data gathered from any other technology incorporated into the device. The display 128 will include both
5 instantaneous measurements and a plot of each measurement versus time as it seems prudent to display for clinical use.

Scanners 126 are provided to scan each of the computers 124 sequentially
10 from about 10 to 1000 times per second, depending upon the particular clinical application. Each of the scanners would be operatively connected to a display 128 that would display the measured data from each of the sensors 112, 116, 118, and 120 in the form of both instantaneous measurements and the historical trends of each parameter. Data derived mathematically, such as local vascular resistance and pulse pressure would likewise be
15 displayed and trended. The display would be combined with selection switches by which each parameter and trend could be selectively displayed.

Attached to each display would be a printer 130 which would be capable of printing current vital parameters and a continuous record of trends and rate of change of each measurement or calculated parameter.

20 Each of the sensors 112, 116, 118, and 120, the hardware drivers 122, each of the recognition and analysis computers 124, each of the scanners 126, each of the displays 128, and each of the printers 130 are connected to a power source 132.

FIG. 7 illustrates a potential configuration for the sound speed sensor with transducer 112 and reflector 114 held apart by stainless steel struts 140. The scale image
25 provides an example of a catheter 110 that is 1 mm diameter and the transducer-reflector separation is 5 mm. The actual dimensions of the catheter may vary according to the particular logistics of construction and function, and are not limited to these dimensions.

FIG. 8 illustrates another potential configuration for the sound speed sensor

with transducer 112 and reflector 114 mounted at opposite ends of a notch cut into the side of the catheter 110.

The particular form(s) that these sound speed measurement devices might assume are not limited and would include any configuration that would allow intravascular measurement of speed of sound in whole blood.

FIG. 9 illustrates a potential configuration of the gas-filled chamber pressure sensor. This particular example shows transducer 134 and reflector 136 mounted in a notch cut into the side of the catheter 110, with a membrane or diaphragm 138 covering and sealing the gas-filled chamber 142. The transducer-reflector separation is 5 mm in this example. The actual dimensions of the chamber, the particular transducer frequency, and type of gas used may vary according to the particular logistics of construction and function. The particular forms that the this sound speed measurement device might assume are not limited and would include any configuration that would allow measurement of the speed of sound in any gas contained within any intravascular device.

The new and improved multiparameter intravascular catheter vital sign measurement device 120 of the invention is a medical device for supplying multiple physiologic and hemodynamic parameter measurements for any clinical medicine, veterinary, military, or research setting where such information is useful to clinicians conducting physical examinations, or monitoring or treating patients or personnel. It would be especially useful in the care of critically ill or injured patients.

When the device is placed intraarterially, it would be capable of accurately and continuously measuring arterial blood pressure, pulse rate, blood density, H/H, temperature, and blood flow velocity without the usual hydraulic arterial-line system, and it would also be capable of trending a calculated local vascular resistance. Vascular volume could be obtained by a common dilution method. When the device is placed intravenously, blood concentration, H/H, and temperature would be continuously monitored.

In addition, device 120 could incorporate any existing or future available intravascular technology for physiologic and hemodynamic measurements which might be

desirable to monitor in the various environments discussed above. Examples of desirable venous or arterial physiologic parameters include, but are not limited to, pO₂, pCO₂, pH, lactic acid levels, electrolytes, PT, PTT. Future advances in technology could bring the eventual incorporation into the catheter of such entities as genetic testing or blood-typing for cross-match for anticipated transfusion. In addition to its value in critical care medicine, the device could have many other uses, including but not limited to use in many types of medical or veterinary research, in clinicians' offices, in military, aerospace, and subsurface marine applications, and in cardiovascular and pharmacological research.

Potentially, any other conventional equipment that can be miniaturized could be mated with the device in order to continuously monitor a multitude of desirable physiologic parameters. The particular existing and available technology that may be incorporated into device 120 will depend upon the amenability of each individual parameter to miniaturization and to its accuracy, precision, licensing and safety restrictions, and compliance to specific regulatory guidelines.

F. Calculation of Total Vascular Hemoglobin Mass:

According to another embodiment, the device 120 can be programmed to determine total vascular hemoglobin mass on an intermittent basis via injection of a small bolus of IV fluid. The usage environment for the device 120 will primarily be the operating room, ICU, emergency department, and military MASH units. Its use is mainly intended for critically ill or injured patients who are suffering from shock or who may have the potential to develop shock from any cause. Additionally, since the instrument has the capability to rapidly measure absolute circulating blood volume, it will also be useful in guiding the management of CHF patients and dehydrated or fluid overloaded patients who are especially fragile due to preexisting renal, cardiac, and pulmonary disease, especially when the need to undergo surgery arises. The device 120 is designed to take the guesswork out of decisions about when to transfuse, how much blood to transfuse, and when to give IV fluids and/or blood vs. pressor agents.

In some embodiments, the device 120 is designed for those particular

patients in which rapid diagnosis is required and those in which it is crucial to maintain hemoglobin and vascular volume within certain limits in order to avoid further stressing already fragile cardiovascular, renal, pulmonary, and/or central nervous systems. These include trauma, sepsis, neurogenic shock, acute renal failure, severe dehydration, major
5 burns, acute respiratory failure with possible volume overload, GI bleeding, and major non-trauma related surgical cases (scheduled or unscheduled) such as open heart surgery, aortic aneurysm, bowel resection, gynecologic, urologic, intra-thoracic or intra-abdominal cancer surgeries, large joint replacement, major open spine surgeries, and major peripheral vascular procedures. The percentage of surgical patients that will require monitoring of the device
10 120 will increase with the age of the patient and degree of preexisting disease. It will also be an important tool in the diagnosis of unexplained hypotension and syncope. The point and purpose of the device 120 is to improve speed of diagnosis and to give guidance to goal directed therapy for these difficult patients, ultimately optimizing care, improving outcomes, and shortening hospital stays, thus limiting iatrogenic complications as well as
15 reducing cost of care.

It is well known to critical care providers that hemoglobin level in an actively hemorrhaging patient is rather meaningless because it does not accurately reflect the overall (whole body) oxygen carrying capacity of the blood. Decisions to transfuse must, therefore, be based on other indicators such as signs and symptoms, hemodynamic
20 parameters, clinical course over time, and test results (including hemoglobin level). Since the device 120 delivers both hemoglobin level and circulating blood volume, as described above, the actual quantity of hemoglobin contained within the circulatory system that is available for oxygen transport can be determined. As a result, a new, more relevant and beneficial hemodynamic parameter, Total Hemoglobin Mass (“THM”), can be introduced.
25 THM is defined as the total amount of hemoglobin contained within the vascular system (typically expressed in grams). Another way to state this is to say that THM represents total blood oxygen carrying capacity. THM is a much more accurate indicator of the entire body’s total oxygen carrying capacity than is the hemoglobin level, which is essentially a simple “spot check” of the hemoglobin concentration. According to some embodiments,
30 the THM could be calculated by the device 120 using the following equation:

$$THM = Hgb \left(\frac{g}{dL} \right) * BV(dL)$$

where *THM* is Total Hemoglobin Mass in grams, *Hgb* is hemoglobin in grams per deciliter, and *BV* is the measured total circulating vascular volume in deciliters. A typical 70kg male patient with normal hemoglobin between 13 and 16 g/dL would have a THM of roughly 600 to 800 grams.

Accordingly, a Total Hemoglobin Mass index (THMi) can be introduced. THMi is defined as THM per kilogram body weight. THM and THMi may be “new” but they are not a foreign concept to physicians who frequently order transfusions and think in terms of how much blood a patient will need. THM and THMi are new tools that will be helpful in determining exactly when and how much blood to transfuse. According to some embodiments, the THMi could be calculated by the device 120 using one of the following equations:

$$THMi = \frac{THM}{Wt(kg)} \quad \text{or} \quad THMi = Hgb \left(\frac{g}{dL} \right) * \frac{BV(dL)}{Wt(kg)}$$

where THMi is the Total Hemoglobin Mass Index in grams per kilogram body weight. Conversely, it follows that when Wt(kg) and BV(dL) are known, then a specific THMi can be applied to help maintain a specific hemoglobin goal:

$$Hgb \left(\frac{g}{dL} \right) = THMi * \frac{Wt(kg)}{BV(dL)}$$

As implied by the latter equation, the caregiver will be able to use specific goal directed infusions of packed RBCs and IV fluids in order to achieve specific hemoglobin and volume goals during resuscitation. If it is a goal to prevent the hemoglobin from dropping below a certain preset level, e.g., 10g/dL, as blood volume is being restored during resuscitation, then THMi can be used to determine the minimum volume of packed RBC's and IV fluids to give at any particular point in time. Since THMi is based upon body weight, and the goal is to return the blood volume back to normal (70mL/kg), the math computes in such a way that a goal of 10g/dl hemoglobin will always equate to a THMi goal

of 7g/dL no matter what the patient weighs. In any patient, therefore, if the THMi is below 7g/kg, then the total body hemoglobin deficiency equals $(7 - THMi) * Wt(kg)$. For example, if the patient weighs 70kg and the THMi is calculated to be 6.3, then the hemoglobin deficiency equals $(7-6.3) \times 70$, or approximately 50 grams. Since a unit of packed RBCs has a hemoglobin level of between 25 and 30g/dL, then a transfusion of 2dL (200mL) of packed RBCs will deliver at minimum of 50 grams and will therefore replenish THMi back to a level of 7g/kg and THM back to 490 grams. Once the THM has been replenished, even if the blood volume were to be restored back to normal with an infusion of normal saline or LR, then the hemoglobin would not be diluted to less than 10g/dL. In most cases, the IV fluids and packed RBCs would be infused simultaneously.

Due to the fact that THM and THMi better characterize total blood oxygen carrying capacity, it can be anticipated that their introduction as new hemodynamic parameters may give rise to the eventual updating of transfusion guidelines which are currently based predominantly upon hemoglobin level.

According to one embodiment, THM could be determined through a rapid injection of a small volume (e.g., 50 to 100mL) of normal saline or Lactated Ringers solution ("LR") in a separate IV site, which allows determination of absolute circulating blood volume. Figure 10 is a graph representing measurement of absolute blood volume from the animal study that was done by Applicant on 9/18/2012. Absolute Circulating Blood Volume is the volume of circulating blood immediately available to the heart for distribution to the central circulation and major organs. It is calculated as the volume of blood into which the indicator (normal saline or lactated ringers) mixes after rapid injection. Data points shown in Figure 10 are displayed every 5 seconds following a rapid bolus injection of Ringers lactate IV solution, in this case, administered via the femoral vein. The graph demonstrates the timing and degree of decrease in blood concentration (dilution) of the circulating intravascular blood volume. The line with diamond indicated data points is the instant data and other line is a 6 point (30 seconds) moving average. It was found that absolute blood volume (ABV) is best calculated using the change in concentration from the initial concentration (C1) to the lowest point of the moving average (C2) by the common equation:

$$ABV=C1*Vi/(C1-C2)$$

Where Vi is the amount of IV fluid injected.

5 It was also found that cardiac output (CO) can be calculated using the time that it takes for the dilute to its first bottom, in this case at 45 seconds after the bolus injection. We will call this point TC3 (time to C3) for reasons of clarity. The equation for this calculation is a simple ratio. Since the definition of CO is the amount of blood circulated in 1 minute (60 seconds), the equation is:

$$CO=ABV*60/TC3$$

10 Prior to the injection, the user will enter the amount of fluid being injected and the patient's weight into the user interface of the device 120, which would be stored in the memory of the device 120. If desired, the hemoglobin goal could be entered into the user interface of the device 120, which would also be stored in memory. After pressing a START button, the user will inject the predetermined volume of fluid over 10-20 seconds.
15 The device 120 will then automatically calculate and display blood volume, cardiac output, and total hemoglobin mass within 60-90 seconds. If the user has entered a predefined hemoglobin goal, the device will also display the minimum volume of packed RBC's that must be transfused in order to meet that hemoglobin goal at that particular point in time.

20 The following is an example of how the device 120 could be used and how THM and THMi might be applied in a trauma resuscitation scenario. Consider an example in which a 70kg male patient with head injury and possible internal injuries arrives at the trauma center having had a single episode of hypotension (BP<90 systolic) which the paramedics have treated with a fluid bolus while en route. The trauma literature indicates that head injured patients do best when hemoglobin level does not drop below 10g/dL. In
25 this case the goal would therefore be to prevent the THMi from dropping below 7.0g/kg and THM from dropping below 490 grams. The caregiver, however, may at first see no indication to order a blood transfusion if the initial hemoglobin level is 12g/dL, even though the patient might have lost a large amount of blood volume from hemorrhage due to yet undetected internal injuries.

In this example, the patient (whose normal blood volume should be approximately 4900mL) has lost 25% of his blood volume due to hidden internal hemorrhage. Using the device 120, the blood volume in this 70kg male can be rapidly measured and found to be 25% below normal, or 3675mL. Knowing the hemoglobin to be 12g/dL and circulating volume to be 3675mL (36.75dL), then THM can be calculated to be 441 grams and the THMi to be 6.3g/kg, both below the goals of 490 grams and 7.0g/dL respectively. In order to prevent the hemoglobin level from dropping below 10g/dL during resuscitation, the patient must therefore be transfused when his hemoglobin level is actually near normal at 12g/dL.

Although the decision to transfuse is always left to the attending physician's best judgment, standard trauma shock resuscitation protocol is to initially refill the vascular space by giving fluid boluses of as much as 30mL/kg. While the fluid is infusing, the patient's response (or lack of response) to the treatment is observed and transfusion is typically ordered based upon the particular physician's intuition and experience. Using the device 120, however, it can easily be predicted that, if the vascular volume is restored by the necessary fluid bolus, then the hemoglobin level will be diluted to the undesirable level of 9g/dL. Furthermore, this scenario assumes that the patient was healthy to begin with and that the bleeding has been controlled or has ceased. The need for immediate transfusion is even more urgent if bleeding is not yet controlled or if the patient has other comorbidities. If indeed all bleeding has been controlled, then a THM of 441 grams and THMi of 6.3g/kg indicate that the patient is now nearly 50 grams short of the goal of 490 grams in terms of total hemoglobin mass (THM). The patient will thus require a transfusion of at least 50 grams of hemoglobin in order to prevent the hemoglobin from dropping below the goal of 10g/dL. Furthermore, since the device 120 provides continuous hemoglobin data, the response to treatment can be assessed in real-time and the circulating volume can be reassessed periodically as indicated by the clinical course of the patient.

The head injured patient may arrive at the trauma center in a hypotensive state with or without internal injuries. Internal bleeding may be suspected but is not yet confirmed or ruled out. Considering the fact that trauma itself and trauma resuscitation is a

very dynamic state, aiming for a hemoglobin level of 10 is rather meaningless and somewhat futile if the circulating blood volume and THM are unknown. To complicate the situation further, the hypotension may be secondary to spinal shock with or without other internal injuries. In the spinal shock patient without internal injuries, rapid fluid infusion may not restore adequate vital signs and may in fact be harmful. In such a case, the device 120 would immediately reveal normal hemoglobin, normal blood volume, normal THM, and normal THMi. Having this information immediately available would allow the caregiver to avoid initial treatment that might be potentially detrimental (albeit still proper according to current guidelines). Having access to such data early in the course of treatment would clarify a choice in favor of more focused therapy such as pressor agents, which would not ordinarily be considered this early in the course of treatment when shock from internal bleeding has not yet been ruled out. The normal readings of the device 120 would also be a clear indication to proceed immediately to the CT scanner as opposed to spending more valuable time contemplating operative intervention or further fluid therapy and/or transfusions for wrongly suspected hemorrhagic shock. The ultimate result would be that the patient's care would be optimized, offering the best chances for survival and improved outcome as well as shortened hospital stay and reduced cost of care. Ultimately, resuscitation guidelines would need to change according to the new information provided by the device 120.

Without a way to accurately measure blood volume, critical treatment decisions made in the early stages of resuscitation are, out of necessity, based upon intuition and experience. The above "multiple-trauma with brain injury" example was chosen because it represents one of most challenging types of cases involving hemodynamic instability and the need for balanced goal directed therapy during resuscitation. Short of giving multiple parallel detailed examples of each type of potential patient, it can be said that the device 120 could similarly be used to optimize the diagnosis and treatment of critically ill patients who are hemodynamically unstable or who are likely to become unstable. In the same way, the device 120 could be used to monitor the above referenced surgical patients who are at risk for sudden changes in blood volume as well as cardiovascular stress from anesthesia and preexisting disease.

Use of the device 120 will reduce the need for frequent blood draws to recheck hemoglobin levels in unstable patients. It is believed to eliminate the need for:

- CVP and pulmonary capillary wedge pressure monitoring.
- Arterial wave form analysis equipment (note* arterial waveform analysis is reliable only in patients who are unconscious and fully ventilator dependent).
- Ultrasound imaging for measurement of the inferior vena cava size (note* this procedure has been found to be operator dependent and reliable only when the vena cava is either very distended or very collapsed).

The device 120 will not eliminate the need for arterial pressure monitoring and in fact may work most optimally when incorporated with an arterial pressure catheter. Noninvasive Cardiac Output Monitoring (NICOM) would be an adjunct to the device 120. The two devices would likely complement each other since NICOM is continuous but not capable of delivering hemoglobin values or blood volume. Continuous noninvasive hemoglobin monitoring is a relatively recent addition to options for hemodynamic monitoring. This oximeter-based technology, however, lacks the precision required for accurate blood volume analysis. It is also known to fail during severe shock when its information would potentially be most essential.

While the invention has been illustrated and described in detail in the drawings and foregoing description, the same is to be considered illustrative and not restrictive in character, it being understood that only selected embodiments have been shown and described and that all changes, equivalents, and modifications that come within the scope of the inventions described herein or defined by the following claims are desired to be protected.

WHAT IS CLAIMED IS:

1. A method of measuring total vascular hemoglobin mass, the method comprising the steps of:

- storing a volume of fluid to be injected using a processor;
- measuring a hemoglobin value in vivo on a substantially continuous basis;
- measuring a total circulating vascular volume based on the volume of fluid to be injected by detecting a change in blood concentration over a period of time upon injection of a fluid into a body;

calculating a total hemoglobin mass based on the measured hemoglobin value and the measured total circulating vascular volume using the following formula:

$$THM = Hgb \left(\frac{g}{dL} \right) * BV(dL)$$

where *THM* is total hemoglobin mass in grams, *Hgb* is the measured hemoglobin value in grams per deciliter, and *BV* is the measured total circulating vascular volume in deciliters; and

displaying the total hemoglobin mass.

2. A method of measuring total vascular hemoglobin mass as recited in claim 1, wherein in the step of measuring the total circulating vascular volume is made by detecting a change in blood concentration after injection of fluid over a period of less than approximate two minutes.

3. The method of measuring total vascular hemoglobin mass as recited in claim 1, further comprising the step of storing a hemoglobin goal.

4. The method of measuring total vascular hemoglobin mass as recited in claim 3, further comprising the step of comparing the calculated total hemoglobin mass with the hemoglobin goal.

5. The method of measuring total vascular hemoglobin mass as recited in claim 4, further comprising the step of determining a minimum volume of packed red blood cells ("RBC's") needed to meet the hemoglobin goal based on the calculated total hemoglobin mass.

6. The method of measuring total vascular hemoglobin mass as recited in claim 1, wherein the fluid injected is: (a) saline; and/or (b) a lactated ringers solution.

7. The method of measuring total vascular hemoglobin mass as recited in claim 1, wherein the total hemoglobin mass is automatically calculated in less than approximately two minutes after injection of fluid into the body.

8. A method of measuring total vascular hemoglobin mass index, the method comprising the steps of:

storing a volume of fluid to be injected and a weight of a patient using a processor;

measuring a hemoglobin value in vivo on a substantially continuous basis;

measuring a total circulating vascular volume based on the volume of fluid to be injected by detecting a change in blood concentration over a period of time upon injection of a fluid into a body;

calculating a total hemoglobin mass index based on the measured hemoglobin value and the measured total circulating vascular volume using the following formula:

$$THMi = Hgb \left(\frac{g}{dL} \right) * \frac{BV(dL)}{Wt(kg)}$$

where THMi is the total hemoglobin mass index in grams per kilogram body weight, *Hgb* is the measured hemoglobin value in grams per deciliter, *BV* is the measured total circulating vascular volume in deciliters, and *Wt* is the weight of the patient.

displaying the total hemoglobin mass.

9. A method of measuring total vascular hemoglobin mass index as recited in claim 8, wherein in the step of measuring the total circulating vascular volume is made by detecting a change in blood concentration after injection of fluid over a period of less than approximate two minutes.

10. The method of measuring total vascular hemoglobin mass index as recited in claim 8, further comprising the step of storing a hemoglobin goal.

11. The method of measuring total vascular hemoglobin mass index as recited in claim 10, further comprising the step of comparing the calculated total hemoglobin mass index with the hemoglobin goal.

12. The method of measuring total vascular hemoglobin mass as recited in claim 11, further comprising the step of determining a minimum volume of packed red blood cells

("RBC's") needed to meet the hemoglobin goal based on the calculated total hemoglobin mass index.

13. The method of measuring total vascular hemoglobin mass index as recited in claim 8, wherein the fluid injected is: (a) saline; and/or (b) a lactated ringers solution.

14. The method of measuring total vascular hemoglobin mass index as recited in claim 1, wherein the total hemoglobin mass index is automatically calculated in less than approximately two minutes after injection of fluid into the body.

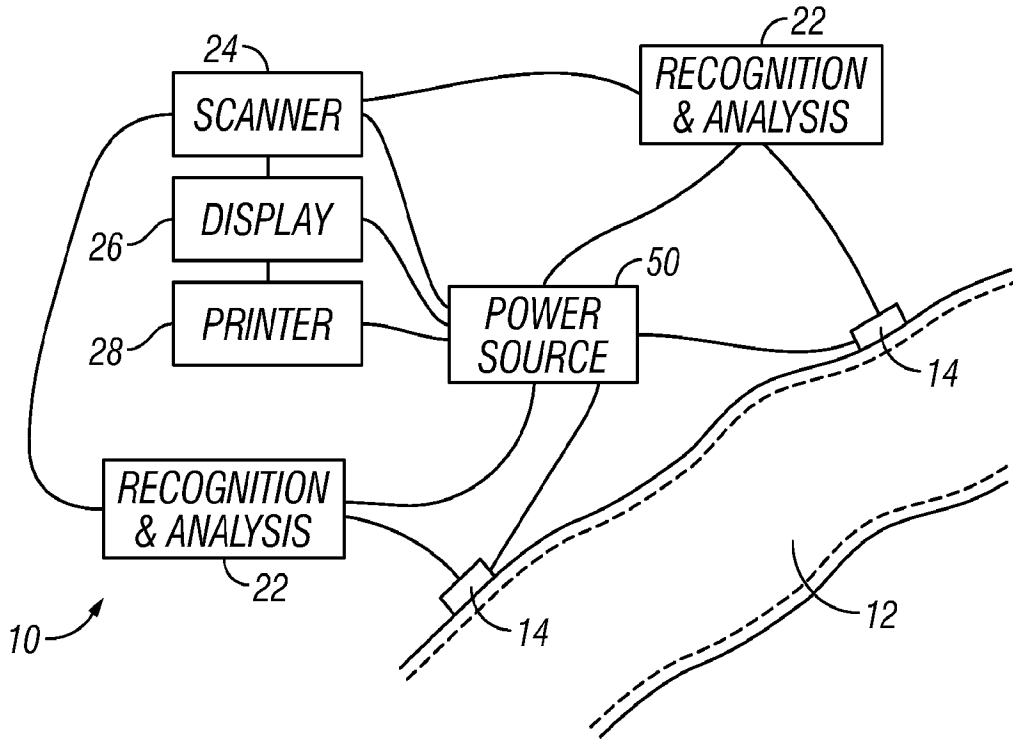

FIG. 1

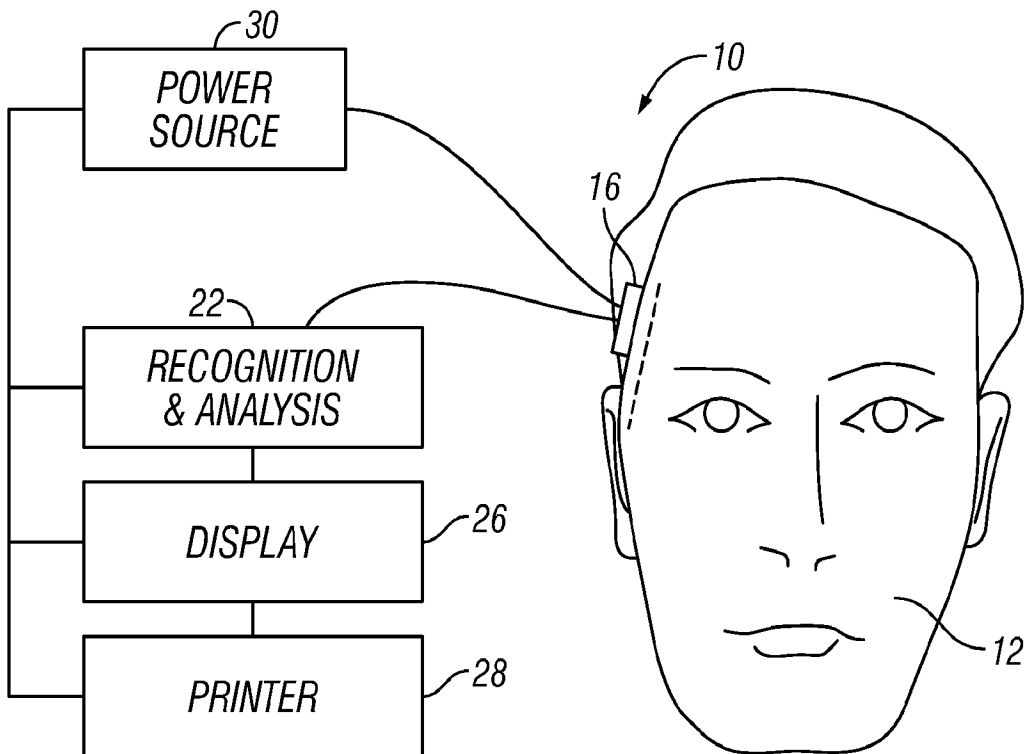

FIG. 2

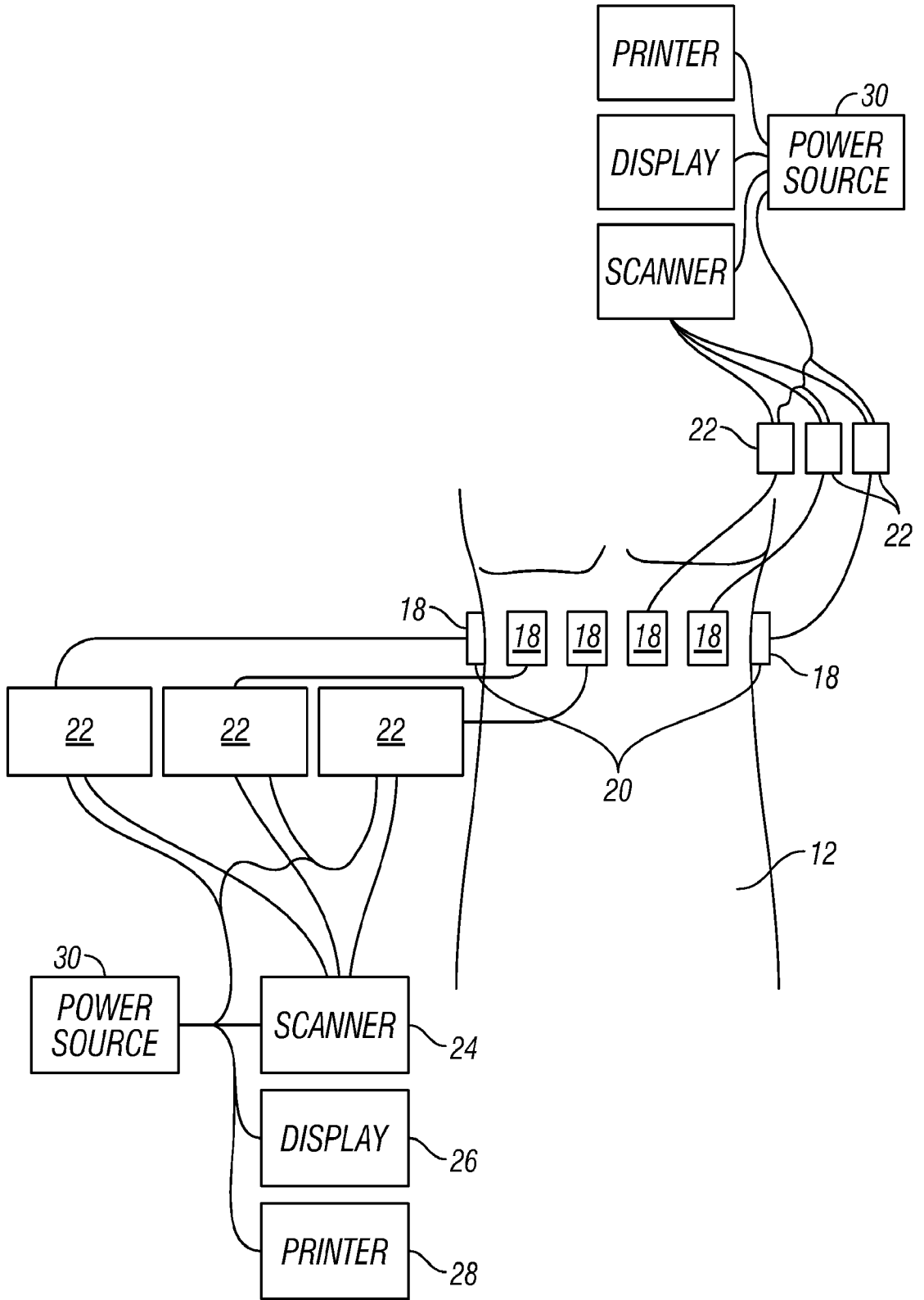

FIG. 3

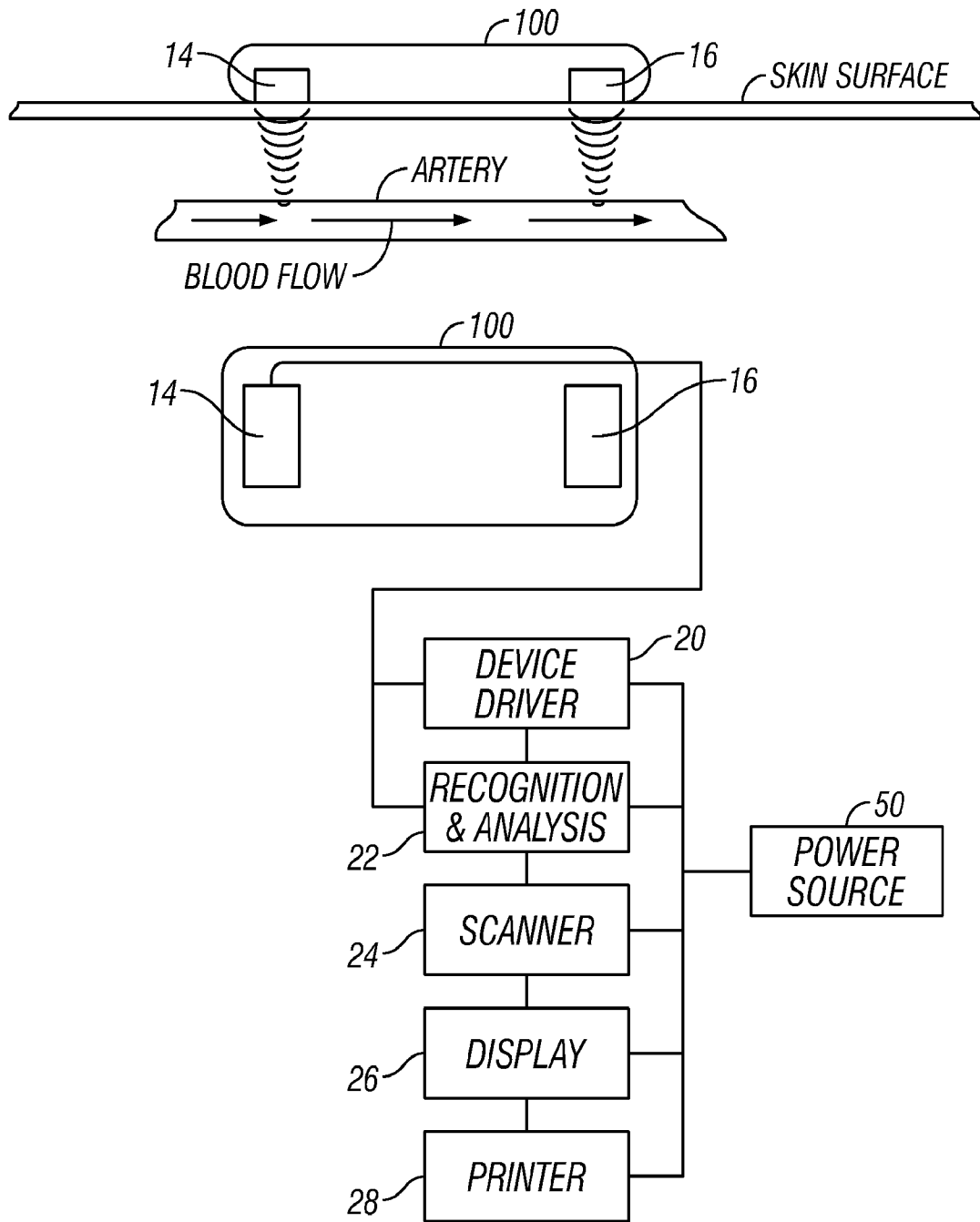
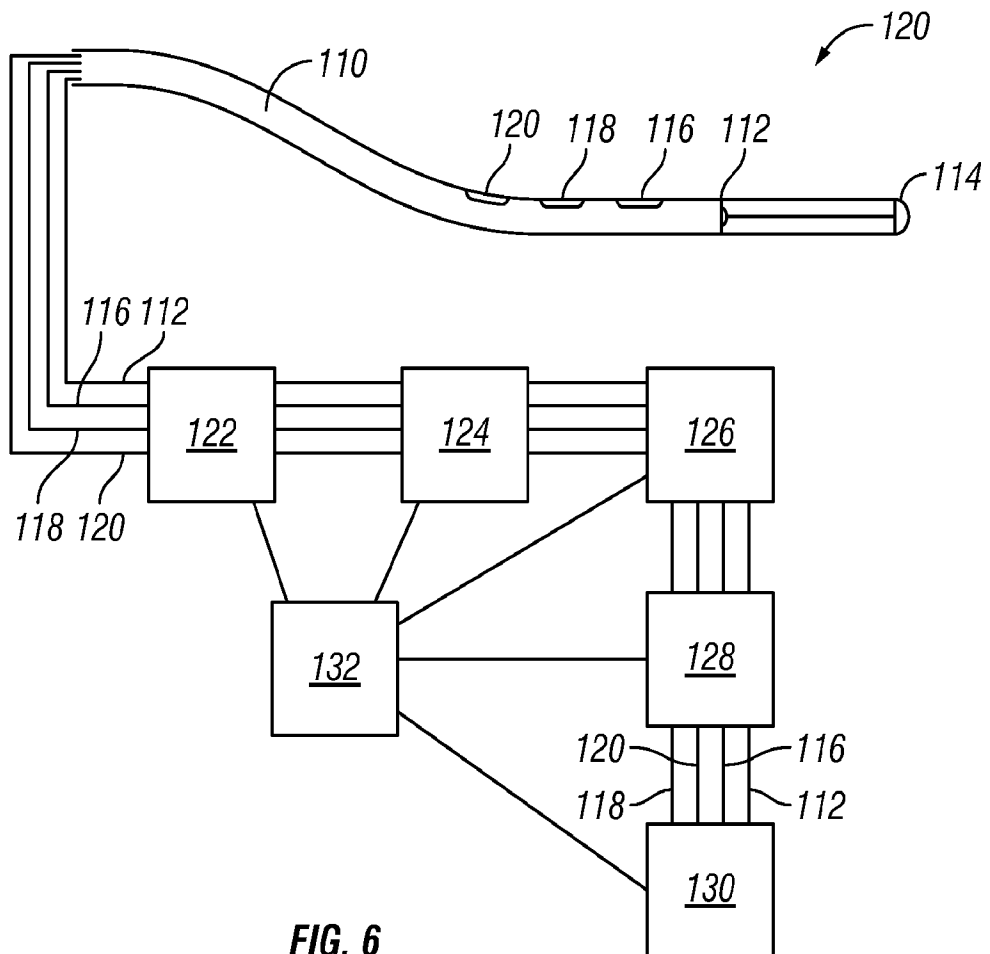
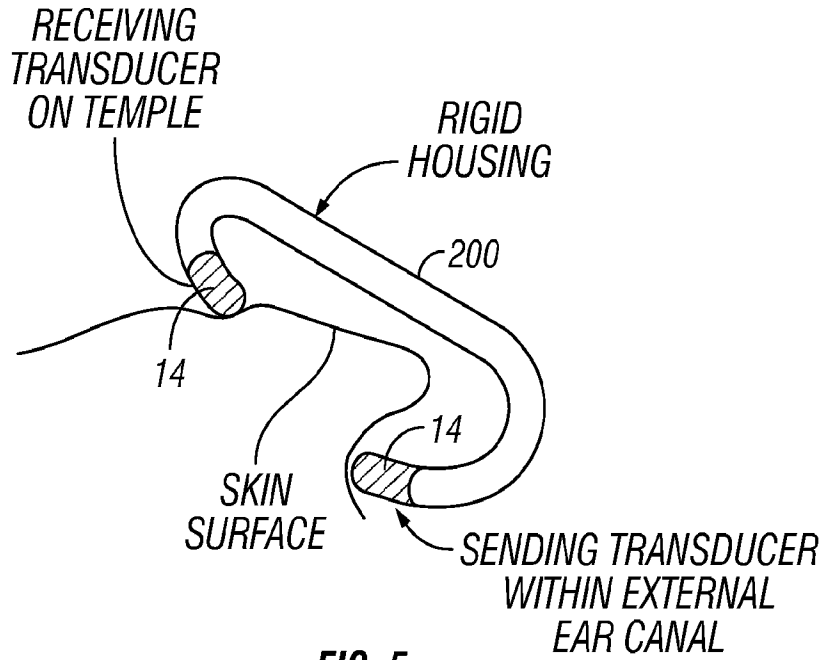

FIG. 4

4/6



5/6

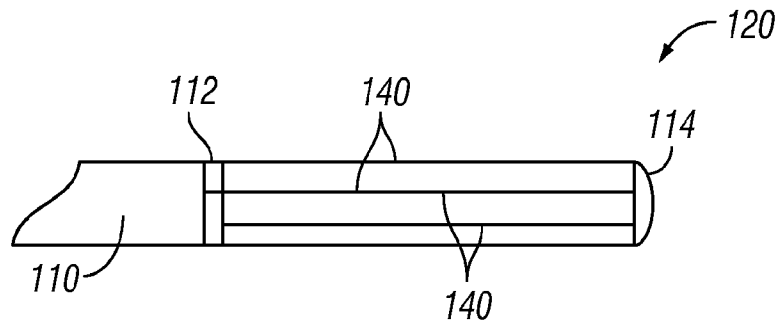

FIG. 7

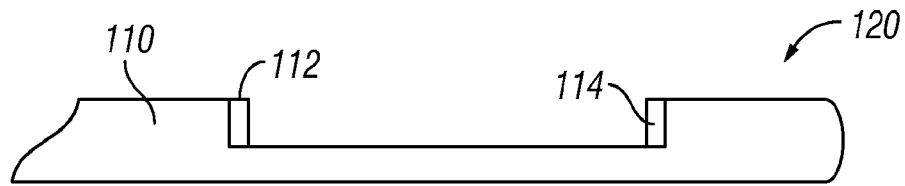

FIG. 8

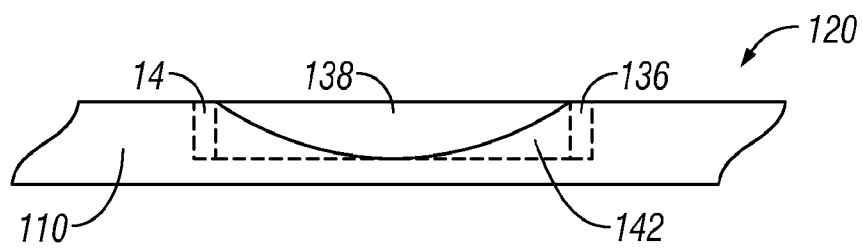

FIG. 9

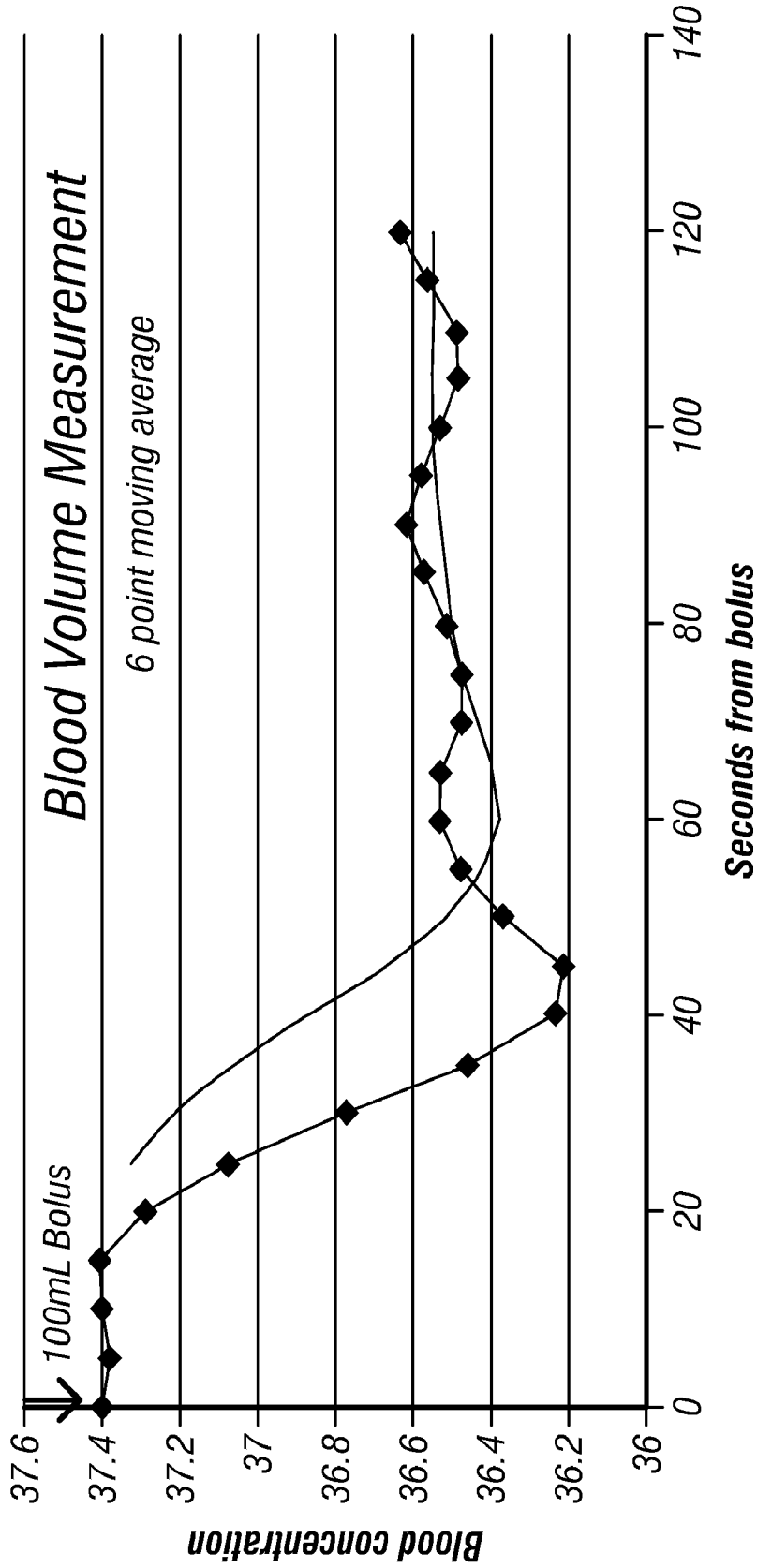

FIG. 10

INTERNATIONAL SEARCH REPORT

International application No.

PCT/US2014/042497

A. CLASSIFICATION OF SUBJECT MATTER IPC(8) - A61B 5/145 (2014.01) CPC - A61B 5/02028 (2014.10) According to International Patent Classification (IPC) or to both national classification and IPC		
B. FIELDS SEARCHED Minimum documentation searched (classification system followed by classification symbols) IPC(8) - A61B 5/00, 5/02, 5/0215, 5/145, 5/1459, 5/151, 8/06; G01N 1/10 (2014.01) CPC - A61B 5/02, 5/02028, 5/021, 5/0215, 5/026, 5/0285, 5/03, 5/14525, 5/14535, 5/14546, 8/06 (2014.10)		
Documentation searched other than minimum documentation to the extent that such documents are included in the fields searched USPC - 436/66, 70; 600/300, 301, 309, 310, 322, 331, 345, 348, 355, 364		
Electronic data base consulted during the international search (name of data base and, where practicable, search terms used) PatBase, Google Patents, Google Scholar, Google		
C. DOCUMENTS CONSIDERED TO BE RELEVANT		
Category*	Citation of document, with indication, where appropriate, of the relevant passages	Relevant to claim No.
Y	US 2009/0270695 A1 (MCEOWEN) 29 October 2009 (29.10.2009) entire document	1-14
Y	US 2004/0054283 A1 (COREY et al) 18 March 2004 (18.03.2004) entire document	1-14
Y	US 2003/0226568 A1 (MCKINLEY et al) 11 December 2003 (11.12.2003) entire document	3-5, 10-12
<input type="checkbox"/> Further documents are listed in the continuation of Box C. <input type="checkbox"/>		
* Special categories of cited documents: "A" document defining the general state of the art which is not considered to be of particular relevance "E" earlier application or patent but published on or after the international filing date "L" document which may throw doubts on priority claim(s) or which is cited to establish the publication date of another citation or other special reason (as specified) "O" document referring to an oral disclosure, use, exhibition or other means "P" document published prior to the international filing date but later than the priority date claimed "T" later document published after the international filing date or priority date and not in conflict with the application but cited to understand the principle or theory underlying the invention "X" document of particular relevance; the claimed invention cannot be considered novel or cannot be considered to involve an inventive step when the document is taken alone "Y" document of particular relevance; the claimed invention cannot be considered to involve an inventive step when the document is combined with one or more other such documents, such combination being obvious to a person skilled in the art "&" document member of the same patent family		
Date of the actual completion of the international search 12 October 2014	Date of mailing of the international search report <div style="font-size: 24pt; font-weight: bold; text-align: center;">04 NOV 2014</div>	
Name and mailing address of the ISA/US Mail Stop PCT, Attn: ISA/US, Commissioner for Patents P.O. Box 1450, Alexandria, Virginia 22313-1450 Facsimile No. 571-273-3201	Authorized officer: Blaine R. Copenheaver PCT Helpdesk: 571-272-4300 PCT OSP: 571-272-7774	