

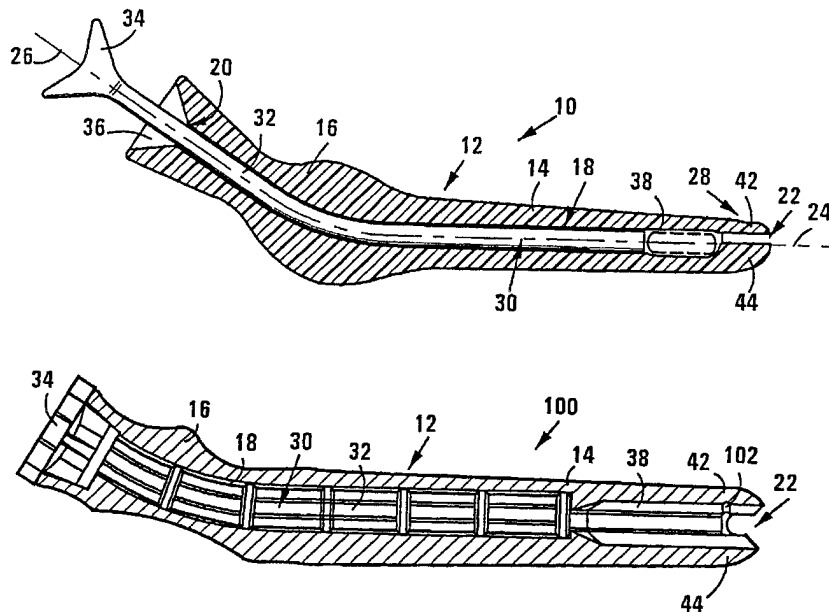

INTERNATIONAL APPLICATION PUBLISHED UNDER THE PATENT COOPERATION TREATY (PCT)

<p>(51) International Patent Classification ⁷ : A61M 37/00, A61F 13/26</p>	<p>A1</p>	<p>(11) International Publication Number: WO 00/66213 (43) International Publication Date: 9 November 2000 (09.11.00)</p>
<p>(21) International Application Number: PCT/IB00/00530 (22) International Filing Date: 26 April 2000 (26.04.00) (30) Priority Data: 99/3006 29 April 1999 (29.04.99) ZA (71)(72) Applicant and Inventor: LAMB, Peter, James, Brian [ZA/ZA]; 12 Clifford Avenue, 1675 Irene (ZA). (74) Agent: VAN DER WALT, Louis, Stephanus; Adams & Adams Pretoria Office, Adams & Adams Place, 1140 Prospect Street, Hatfield, P.O. Box 1014, 0001 Pretoria (ZA).</p>	<p>(81) Designated States: AE, AG, AL, AM, AT, AU, AZ, BA, BB, BG, BR, BY, CA, CH, CN, CR, CU, CZ, DE, DK, DM, DZ, EE, ES, FI, GB, GD, GE, GH, GM, HR, HU, ID, IL, IN, IS, JP, KE, KG, KP, KR, KZ, LC, LK, LR, LS, LT, LU, LV, MA, MD, MG, MK, MN, MW, MX, NO, NZ, PL, PT, RO, RU, SD, SE, SG, SI, SK, SL, TJ, TM, TR, TT, TZ, UA, UG, US, UZ, VN, YU, ZA, ZW, ARIPO patent (GH, GM, KE, LS, MW, SD, SL, SZ, TZ, UG, ZW), Eurasian patent (AM, AZ, BY, KG, KZ, MD, RU, TJ, TM), European patent (AT, BE, CH, CY, DE, DK, ES, FI, FR, GB, GR, IE, IT, LU, MC, NL, PT, SE), OAPI patent (BF, BJ, CF, CG, CI, CM, GA, GN, GW, ML, MR, NE, SN, TD, TG).</p> <p>Published <i>With international search report.</i></p>	

(54) Title: DEVICE FOR DEPOSITING A NON-FLOWABLE OBJECT OR A NON-FLOWABLE MEDICAMENT IN A BODY CAVITY



(57) Abstract

A device (100) for depositing a non-flowable object or a non-flowable medicament in a body cavity includes an elongate body (12) which includes an elongate barrel (14) with a passage (18), configured to receive a non-flowable object or medicament, extending through the body (12). The passage (18) has an outlet (22) at a free end of the barrel (14), a portion of the passage (18) being curved. The device (10) also includes an ejector or plunger (30) which can be displaced along the passage (18) to push a non-flowable object or medicament received in the passage (18) out of the passage (18) through the outlet (22) thereof.

FOR THE PURPOSES OF INFORMATION ONLY

Codes used to identify States party to the PCT on the front pages of pamphlets publishing international applications under the PCT.

AL	Albania	ES	Spain	LS	Lesotho	SI	Slovenia
AM	Armenia	FI	Finland	LT	Lithuania	SK	Slovakia
AT	Austria	FR	France	LU	Luxembourg	SN	Senegal
AU	Australia	GA	Gabon	LV	Latvia	SZ	Swaziland
AZ	Azerbaijan	GB	United Kingdom	MC	Monaco	TD	Chad
BA	Bosnia and Herzegovina	GE	Georgia	MD	Republic of Moldova	TG	Togo
BB	Barbados	GH	Ghana	MG	Madagascar	TJ	Tajikistan
BE	Belgium	GN	Guinea	MK	The former Yugoslav Republic of Macedonia	TM	Turkmenistan
BF	Burkina Faso	GR	Greece			TR	Turkey
BG	Bulgaria	HU	Hungary	ML	Mali	TT	Trinidad and Tobago
BJ	Benin	IE	Ireland	MN	Mongolia	UA	Ukraine
BR	Brazil	IL	Israel	MR	Mauritania	UG	Uganda
BY	Belarus	IS	Iceland	MW	Malawi	US	United States of America
CA	Canada	IT	Italy	MX	Mexico	UZ	Uzbekistan
CF	Central African Republic	JP	Japan	NE	Niger	VN	Viet Nam
CG	Congo	KE	Kenya	NL	Netherlands	YU	Yugoslavia
CH	Switzerland	KG	Kyrgyzstan	NO	Norway	ZW	Zimbabwe
CI	Côte d'Ivoire	KP	Democratic People's Republic of Korea	NZ	New Zealand		
CM	Cameroon			PL	Poland		
CN	China	KR	Republic of Korea	PT	Portugal		
CU	Cuba	KZ	Kazakstan	RO	Romania		
CZ	Czech Republic	LC	Saint Lucia	RU	Russian Federation		
DE	Germany	LI	Liechtenstein	SD	Sudan		
DK	Denmark	LK	Sri Lanka	SE	Sweden		
EE	Estonia	LR	Liberia	SG	Singapore		

DEVICE FOR DEPOSITING A NON-FLOWABLE OBJECT OR A NON-FLOWABLE MEDICAMENT IN A BODY CAVITY

THIS INVENTION relates to a device for depositing a non-flowable object or a non-flowable medicament in a body cavity.

5 Various conventional devices for depositing a non-flowable medicament or object, such as a tablet in body cavities, such as the vagina and rectum, exist. Typically, these conventional devices comprises a blunt, straight, hollow tube or barrel into which a plunger or piston or ejector can be inserted from one end, with a medicament or object chamber being provided at an
10 opposed end. All of the conventional devices suffer from at least some of the following problems:

 The conventional device is of a hard and non-pliable material so there is no bend or give during insertion of the device into a vagina. This rigidity makes vaginal insertion more difficult and painful. Often women do not know
15 that the vagina is angled upwards from its opening and that it is not horizontal. After inserting a leading end of the conventional device through the vaginal opening in the horizontal direction, the leading end collides with the back wall of the vagina, which is painful and causes the user to think that the device has reached the limit of the vagina. The user then deposits the medicament or object
20 at a too shallow depth in the vagina. No stop guard is provided to limit the depth of insertion of the conventional devices into the vagina. If the device is

inserted to the full depth of the vagina and collides with the vaginal vault, considerable pain is caused. This lack of depth control is particularly hazardous in the case of a pregnant woman. Some conventional devices have leading ends which flare outwards which make them even more difficult to insert into a vagina. Conventional devices can only comfortably be inserted into a vagina when the woman is lying on her back with her knees flexed. It is difficult to insert conventional devices which are often difficult to grip and difficult to control when being inserted into a vagina.

It is an object of this invention to provide means which alleviate at least some of these problems.

According to a first aspect of the invention, there is provided a device for depositing a non-flowable object or a non-flowable medicament in a body cavity, the device including

an elongate body which includes an elongate barrel with a passage, configured to receive a non-flowable object or medicament, extending through the body, the passage having an outlet at a free end of the barrel, a portion of the passage being curved; and

an ejector or plunger which can be displaced along the passage to push a non-flowable object or medicament received in the passage out of the passage through the outlet thereof.

A barrel may be penile-shaped at least in cross section.

According to a second aspect of the invention, there is provided a device for depositing a non-flowable object or a non-flowable medicament in a body cavity, the device including

an elongate body which includes an elongate barrel with a passage, configured to receive a non-flowable object or medicament, extending through the body, the passage having an outlet at a free end of the barrel, the barrel being penile-shaped at least in cross section; and

an ejector or plunger which can be displaced along the passage to push a non-flowable object or medicament received in the passage out of the passage through the outlet thereof.

5 In this specification, the term "non-flowable medicament" is intended to include tablets, capsules, suppositories, pills, bougies, or the like.

A portion of the passage of the device according to the second aspect of the invention may be curved. The passage is typically round or circular in cross-section.

10 The passage may have an inlet remote from its outlet. The curved portion of the passage may render a centrally disposed longitudinal axis of the barrel and a centrally disposed axis through the inlet of the passage at an obtuse angle relative to each other. The obtuse angle may be between 170° and 135° . Preferably, the obtuse angle is between 160° and 140° , and most preferably between 155° and 145° , and is thus selected to correct for vaginal inclination.

15 The body of the device may include a gripping portion from which the barrel extends. The inlet of the passage may thus be in the gripping portion, which may be thickened compared to the barrel, thus also functioning in use as a stop formation, limiting the length of the body of the device which may be introduced into a body cavity.

20 The curved portion of the passage is typically located in the gripping portion of the body, so that the portion of the passage in the barrel is typically linear, allowing at least a portion of the barrel to be straight. Preferably, the entire barrel is straight, which is an advantage, since the human vagina is straight and not curved.

25 An outlet end portion of the barrel may have the general shape or may incorporate at least some of the design features of a glans penis. Thus, the

barrel may have a rounded point which flares back like the corona of a glans penis and which in use lifts the opposing vaginal walls apart when the barrel is inserted into a vagina by a wedging action. The roughly triangular cross-section of the barrel, similar to that of a penis, allows the smallest area of contact or friction with a posterior vaginal wall. Side walls of the barrel are thus in use angled away from lateral walls of the vagina, with a relatively broad superior wall of the barrel being stabilized by low pressure contact with the anterior vaginal wall.

The ejector or plunger may have a flexible rod, allowing the rod to bend to follow the curvature of the passage when it is displaced along the passage. The rod may be of a synthetic plastics or polymeric material, such as polypropylene or the like.

The passage may include a medicament or object chamber for receiving the non-flowable medicament or object. The chamber may be spaced from the outlet of the passage, allowing a part of the barrel, above the outlet, and a part of the barrel, below the outlet, to be displaced or forced towards each other when the barrel is being inserted into a body cavity, thus at least partially closing off the outlet whilst the barrel is being inserted into the body cavity and preventing the objet or medicament from scraping against or injuring body tissue material, such as the vaginal mucosa.

At least the barrel may be of a material having a Shore A hardness between 40 and 80, e.g. 70. Thus, the barrel may be of a synthetic plastics or polymeric material, such as silicone rubber, having a suitable hardness. The gripping portion may be of a thermoplastic material, with the barrel and the gripping portion being moulded or fused together. Instead, the barrel and the gripping portion may be fitted together by other means, such as glue or mechanical attachment means or combi moulding, thus advantageously allowing the gripping portion to be of a thermoplastic material which has a lower maximum working temperature than the moulding temperature of the material

of which the barrel is formed, and which may thus be cheaper. In another embodiment of the invention, the gripping portion and the barrel may both be of the same synthetic or polymeric plastics material, e.g. silicone rubber, the body of the device thus being monolithic and integrally moulded. Instead, the body and the ejector or plunger may be manufactured from paper or paper pulp, rendering the device disposable. The material may be selected to be biodegradable or to allow the device to be flushed safely down a toilet.

The barrel may have a length of between 60mm and 100mm, e.g. 70mm and a maximum external diameter of between 10mm and 20mm, e.g. 17mm, when the device is intended for a non-flowable medicament.

The outlet of the passage may be in the form of a slit extending between opposed sides of the barrel and may be located on the longitudinal axis of the barrel.

The body may define gripping surfaces such that the body can be gripped between a thumb, and index finger and a middle finger of one hand of a user. The gripping surfaces may be arranged such that when the body is being held between the three fingers, with the middle finger and the index finger touching the body in respective areas and the body being orientated such that said areas are in the same horizontal plane, the barrel projects upwardly away from said horizontal plane at an angle of between 45 ° and 10 °.

The passage may be shaped and dimensioned to receive a tampon. The barrel may thus include a longitudinally extending slit through which a string of the tampon received in the passage can protrude.

In one embodiment of the invention, the slit may extend from the outlet and may form a right angle at an end of a longitudinally extending portion thereof remote from the outlet to extend transversely across an upper surface

displaceable in flip top fashion. This allows insertion of a solid object such as a tampon into the barrel from above, without having to feed the solid object into the barrel through the outlet.

5 The ejector or plunger may include a thumb grip at a free end of its rod, the gripping portion of the body defining a recess for the thumb grip so that almost all of the ejector or plunger can be received inside the body of the device when the ejector or plunger is pushed as far into the passage as it can go.

The invention will now be described, by way of example, with reference to the accompanying diagrammatic drawings in which

10 Figure 1 is a sectioned side view of an embodiment of a device in accordance with the invention for depositing a non-flowable medicament in a body cavity;

Figure 2 is a top plan view of the device of Figure 1;

Figure 3 is a bottom plan view of the device of Figure 1;

15 Figure 4 is a front end view of the device of Figure 1;

Figure 5 is a rear end view of the device of Figure 1;

Figure 6 is a sectioned side view of another embodiment of a device in accordance with the invention for depositing a non-flowable medicament or a non-flowable object in a body cavity;

20 Figure 7 is a top plan view of the device of Figure 6;

Figure 8 is a bottom plan view of the device of Figure 6;

Figure 9 is a front end view of the device of Figure 6; and

Figure 10 is a rear end view of the device of Figure 6.

25 Referring to Figures 1 to 5 of the drawings, reference numeral 10 generally indicates an embodiment of a device in accordance with the invention for depositing a non-flowable medicament or object in a body cavity, such as a vagina. The device 10 includes an elongate monolithic body 12 which comprises

an elongate barrel 14 and a gripping portion 16 from which the barrel 14 extends.

5 The barrel 14 and the gripping portion 16 are integrally moulded from a synthetic plastics or polymeric material such as a silicone rubber and has a Shore A hardness of about 70. A passage 18 extends through the gripping portion 16 and the barrel 14. The passage 18 has an inlet 20 in the gripping portion 16 and an outlet 22 at a free end of the barrel 14, remote from the gripping portion 16. A portion of the passage 18 between the inlet and the outlet and located in the gripping portion 16, is curved in side view, as can be clearly seen in Figure 1 of the drawings. The passage 18 is round in cross-section.

10 The curved portion of the passage 18 between its inlet 20 and its outlet 22 renders a centrally disposed longitudinal axis 24 of the barrel 14 and a centrally disposed axis 26 through the inlet 20 of the passage 18, at an obtuse angle of 150° relative to each other (see Figure 1), and this angle thus matches the angle of inclination of the vagina of a standing woman relative to the horizontal.

15 The barrel 14 is generally penile shaped and is thus roughly triangular in cross-section, similar to the cross section of a penis. More accurately, a cross-sectional outline of the barrel 14 falls on the outline of a triangle. An outlet end portion 28 of the barrel 14, remote from the gripping portion 16, generally has the shape of a glans penis. A bottom surface of the end portion 28 has a sled-like curve in side view to inhibit abrasion of the posterior vaginal wall in use. The barrel 14 thus has a rounded point which flares back like the corona of a glans penis and which in use lifts and wedges the opposing vaginal walls apart when the barrel 14 is inserted into a vagina.

25 The outlet 22 of the passage 18 is in the form of a slit extending between opposed sides of the barrel 14 and is located in an upper half of the

outlet end portion 28, to avoid scraping vaginal exudate into the outlet 22 during insertion of the barrel 14 into a vagina in use.

5 The device 10 includes a piston or ejector or plunger 30 which can be displaced along the passage 18 and which includes a flexible rod 32 of polypropylene. The rod 32 is thus able to follow the curvature of the passage 18 when the plunger 30 is displaced along the passage 18. The plunger 30 includes an ergonomically designed thumb grip 34 at a free end of the flexible rod 32. As can be clearly seen in Figure 1 of the drawings, the gripping portion 16 of the body 12 defines a recess 36 for the thumb grip 34 so that almost all of the plunger 30 can be received inside the body 12 when the plunger 30 is pushed as far into the passage 18 as it can go.

10 The passage 18 includes or defines a medicament or object chamber 38 (see Figure 1) for receiving the non-flowable medicament or non-flowable object. The chamber 38 is spaced from the outlet 22 of the passage and is in the form of a widening of the passage 18 tailored to receive a tablet or capsule or tampon or the like.

15 Roughened and depressed gripping surfaces 40 are provided on an external top surface and an external bottom surface of the gripping portion 16 of the body 12.

20 The barrel 14 is approximately 70mm long and has a maximum external diameter of about 17mm.

25 The device 10 is particularly, though not necessarily exclusively suitable for depositing a non-flowable medicament, such as a tablet or capsule, in a vagina. In use, the ejector or plunger 30 is withdrawn from the passage 18 at least far enough so that it does not protrude into the chamber 38, as shown in Figure 1 of the drawings, and the non-flowable medicament is placed inside the medicament chamber by inserting it through the outlet 22. The barrel 14 is

then inserted into a body cavity, such as the vagina of a human female until the gripping portion 16 limits the part or length of the body 12 of the device 10 which can be introduced into the vagina. Thus, the gripping portion 16 also functions in use as a stop formation. The gripping portion 16 affords a large comfortable grip for the hand of the person inserting the barrel 14 into the vagina.

As will be appreciated, since the body 12 is of a silicone rubber and thus quite flexible, a part or upper lip 42 of the barrel 14, above the outlet 22, and a part or lower lip 44 of the barrel 14, below the outlet 22 are displaced or forced towards each other whilst the barrel 14 is being inserted into the vagina. Thus, the outlet 22 is closed off whilst the barrel 14 is being inserted into the vagina, inhibiting intrusion of vaginal exudate into the passage 18 through the outlet 22. The flexibility of the lips 42, 44 also allows for easy insertion of the non-flowable medicament into the chamber 38 and prevents abrasion or injury to the vaginal mucosa by a sharp-edged non-flowable medicament, e.g. a vaginal tablet.

By enlarging the barrel 14 and the chamber 38, the device 10 can also easily be adapted for use in inserting a tampon in a vagina. Typically, in such a case, the barrel 14 will include a longitudinally extending slit through which a string of the tampon can protrude.

When the barrel 14 is fully inserted into the vagina, the ejector or plunger 30 is pushed into the body 12 as far as it can go, forcing the non-flowable medicament or solid object out of the chamber 38, through the outlet 22, and thus depositing the non-flowable medicament or object in the vagina. The barrel 14 is then withdrawn from the vagina.

Referring to Figures 6 to 10 of the drawings, reference numeral 100 generally indicates another embodiment of a device in accordance with the invention for depositing a solid object, such as a non-flowable medicament or a

non-flowable object, in a body cavity, such as a vagina. The device 100 is similar to the device 10, and unless otherwise indicated, the same parts or features are indicated by the same reference numerals used in relation to the device 10.

5 The body 12 of the device 100 is of Krayton G 2705 material having a Shore A hardness of 55. The ejector or plunger 30 is of the same material.

10 Unlike the outlet 22 of the device 10, the outlet 22 of the device 100 is located on a central longitudinal axis of the barrel 14 (not shown). Also unlike the device 10, the gripping portion 16 of the body 12 of the device 100 does not define a recess which can accommodate the thumb grip 34. Instead, when the ejector or plunger 30 is inserted fully into the passage 18, the thumb grip 34 abuts an end of the body 12 remote from the outlet 22.

15 The device 100 has a semi-circular 0.5 mm deep groove 102 in the upper lip 42 of the barrel 14. This facilitates bending of the upper lip 42 towards the lower lip 44 during insertion of the barrel 14 into a vagina thereby to close the outlet 22 off whilst the barrel 14 is being inserted into the body cavity. The groove 102 also facilitates the passage of a solid non-flowable object from the chamber 38 out through the outlet 22, by allowing the upper lip
20 42 to move away from the lower lip 44.

25 The device 100 is used in similar fashion to the device 10. It is to be appreciated that, when the body 16 is gripped between a thumb, an index finger and a middle finger of one hand of a user, with the thumb touching the upper gripping surface 40 and the index finger and middle finger touching the lower gripping surface 40, and with areas on the lower surface 40 touched by the middle finger and the index finger being orientated such that they are in the same horizontal plane, the barrel 14 projects upwardly away from the horizontal plane

at an angle of about 30 °. If a woman holds the device 100 such that said areas touched by the middle and index finger are in line at an angle of about 120 ° to the horizontal, which is a natural holding position, the barrel 14 projects upwardly at an angle of about 150 ° relative to the horizontal, which is the angle of inclination of the vagina of a standing woman relative to the horizontal, as hereinbefore mentioned.

The Applicant believes that the device 10, 100 as illustrated, and particularly when intended to deposit a non-flowable medicament such as a capsule or tablet, or a solid object such as a tampon, in a vagina, has the following advantages:

The length of the barrel 14 is not intimidating, but nonetheless provides effective depth of deposition of the non-flowable medicament or the object. The barrel 14 is of a relatively soft, elastic material which is less difficult and painful to insert than the barrel of conventional devices. The material is easier for the fingers to grip securely and the grippability of the device is further improved by the gripping surfaces 40. The generally triangular, penile-like cross-section of the barrel 14 (see Figure 4) is easier and more comfortable to insert into a vagina. Friction against the back vaginal wall is reduced.

The angular arrangement of the barrel 14 relative to the inlet 20 of the passage 18 promotes easier advancement of the barrel 14 up the vagina. There is a built-in correction for the direction or inclination of the vaginal cavity, which causes less damage and discomfort to the user. The barrel 14 can be inserted whilst the user is sitting or standing and the procedure is therefor much easier and more comfortable to accomplish physically and much less an affront to a female's dignity.

The glans penis-like outlet end portion 28 of the barrel 14 of the device 10 is easier and more comfortable to insert than the leading end portions of conventional devices. The shape and location of the outlet 22 of the barrel

14 provides for better hygiene and promotes comfort when the barrel 14 is inserted into the vagina, by eliminating any scraping effect on the back wall of the vagina.

5 The thickened gripping portion 16 ensures automatic depth control when the barrel 14 is inserted into a vagina.

The integrally moulded design of the gripping portion 16 and the barrel 14 provides the device 10, 100 with a degree of flexibility, which enhances comfort and ease when the barrel 14 is inserted into a vagina.

10 The gripping portion 16 provides a large comfortable handle for the device 10. It affords a secure grip and therefor better control of the device 10 during insertion of the barrel 14 into the vagina.

CLAIMS:

1. A device for depositing a non-flowable object or a non-flowable medicament in a body cavity, the device including

5 an elongate body which includes an elongate barrel with a passage, configured to receive a non-flowable object or medicament, extending through the body, the passage having an outlet at a free end of the barrel, a portion of the passage being curved; and

10 an ejector or plunger which can be displaced along the passage to push a non-flowable object or medicament received in the passage out of the passage through the outlet thereof.

2. A device as claimed in claim 1, in which the barrel is penile-shaped at least in cross section.

3. A device for depositing a non-flowable object or a non-flowable medicament in a body cavity, the device including

15 an elongate body which includes an elongate barrel with a passage, configured to receive a non-flowable object or medicament, extending through the body, the passage having an outlet at a free end of the barrel, the barrel being penile-shaped at least in cross section; and

20 an ejector or plunger which can be displaced along the passage to push a non-flowable object or medicament received in the passage out of the passage through the outlet thereof.

4. A device as claimed in claim 3, in which a portion of the passage is curved.

25 5. A device as claimed in claim 1 or claim 2 or claim 4, in which the passage has an inlet remote from its outlet and in which the curved portion of the passage renders a centrally disposed longitudinal axis of the barrel and a

centrally disposed axis through the inlet of the passage at an obtuse angle of between 170 ° and 135 ° relative to each other.

6. A device as claimed in claim 5, in which the obtuse angle is between 160 ° and 140 ° relative to each other.

5 7. A device as claimed in claim 5 or claim 6, in which the body of the device includes a gripping portion from which the barrel extends, the inlet of the passage being in the gripping portion, and the gripping portion being thickened compared to the barrel, the gripping portion thus also functioning in use as a stop formation, limiting the length of the body of the device which may be
10 introduced into a body cavity.

8. A device as claimed in claim 7, in which the curved portion of the passage is located in the gripping portion of the body, and in which the entire barrel is straight.

15 9. A device as claimed in any one of the preceding claims, in which an outlet end portion of the barrel has the general shape, or incorporates at least some of the design features of a glans penis.

10. A device as claimed in any one of the preceding claims, in which the ejector or plunger includes a flexible rod, allowing the rod to bend.

20 11. A device as claimed in any one of the preceding claims, in which the passage includes a medicament or object chamber for receiving the non-flowable medicament or object.

25 12. A device as claimed in claim 11, in which the chamber is spaced from the outlet of the passage, allowing a part of the barrel, above the outlet, and a part of the barrel, below the outlet, to be displaced or forced towards each other when the barrel is being inserted into a body cavity, thus at least partially

closing off the outlet whilst the barrel is being inserted into the body cavity and preventing the object or medicament from scraping against or injuring body tissue material.

5 13. A device as claimed in any one of the preceding claims, in which the barrel includes a longitudinally extending slit through which a string of a tampon received in the passage can protrude, the passage being shaped and dimensioned to receive a tampon.

14. A device as claimed in any one of the preceding claims, in which at least the barrel is of a material having a Shore A hardness between 40 and 80.

10 15. A device as claimed in any one of the claims 1 to 14 inclusive, in which the body and the ejector or plunger are manufactured from paper or paper pulp, rendering the device disposable.

15 16. A device as claimed in any one of the preceding claims, in which the body defines gripping surfaces such that the body can be gripped between a thumb, an index finger and a middle finger of one hand of a user, the gripping surfaces being arranged such that when the body is being held between the three fingers, with the middle finger and the index finger rouching the body in respective areas and the body being orientated such that said areas are in the same horizontal plane, the barrel projects upwardly away from said horizontal
20 plane at an angle of between 45 ° and 10 °.

17. A device as claimed in claim 1 or claim 3, substantially as herein described and illustrated.

18. A new device, substantially as herein described.

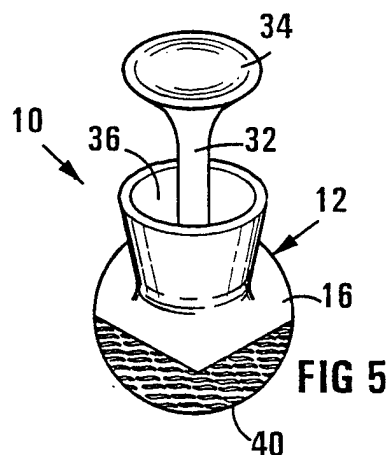
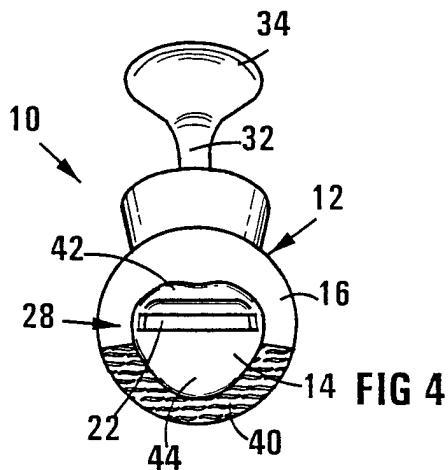
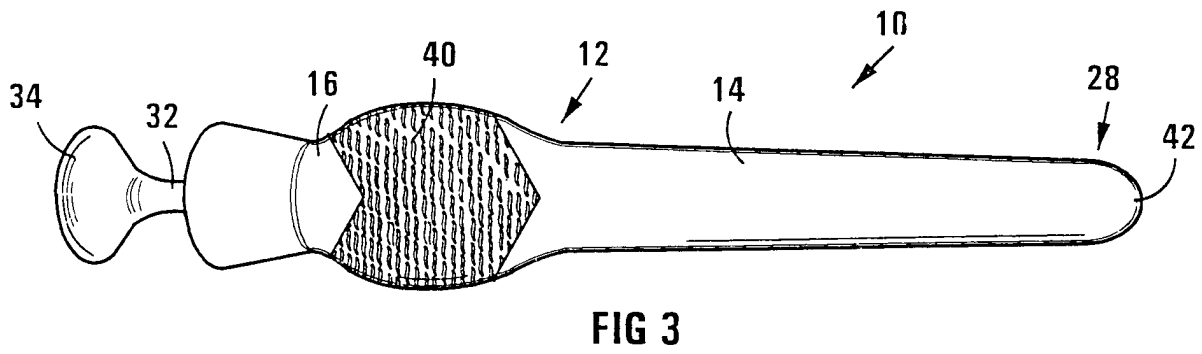
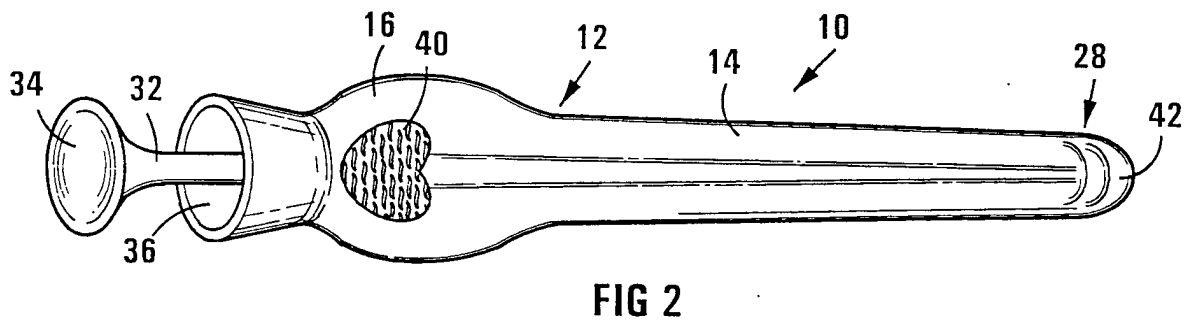
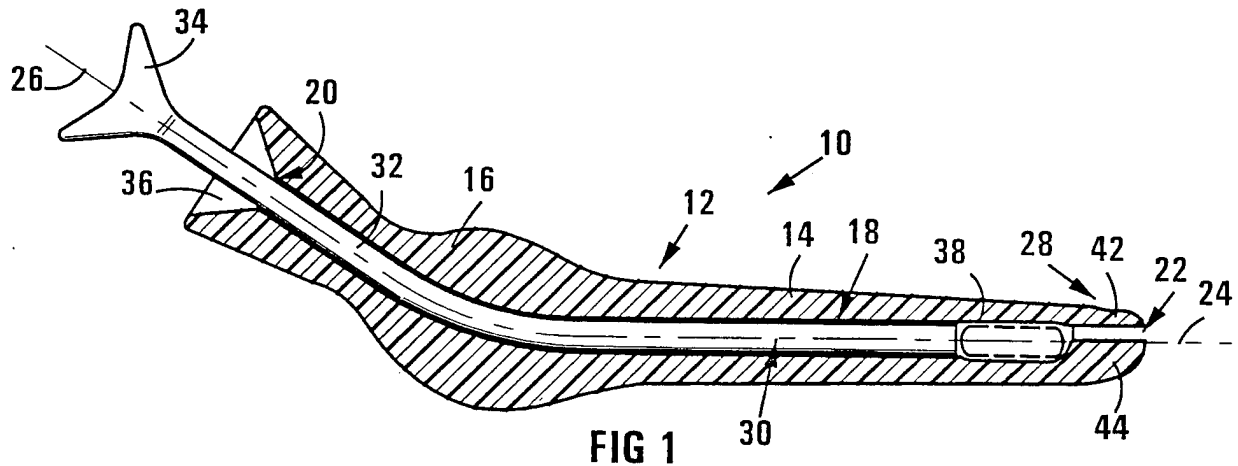

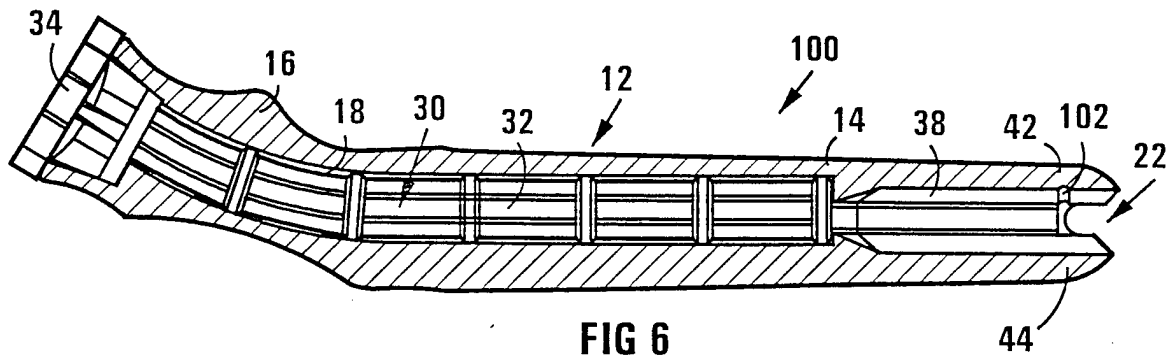

FIG 6

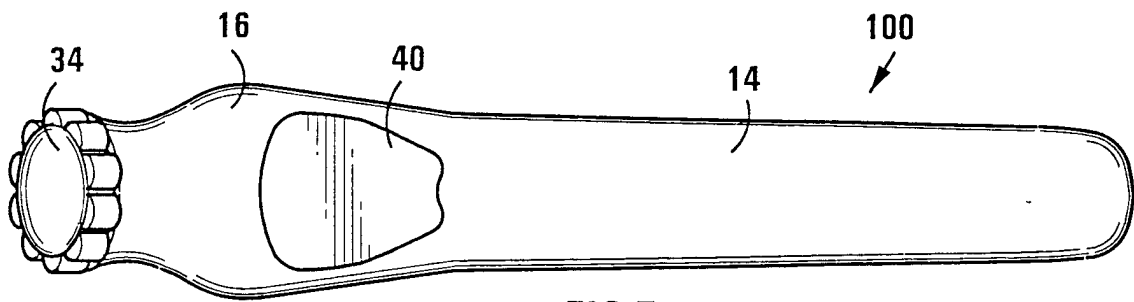

FIG 7

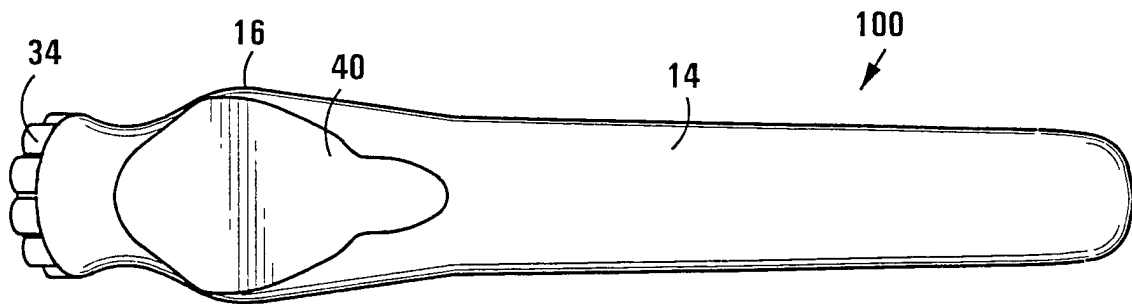

FIG 8

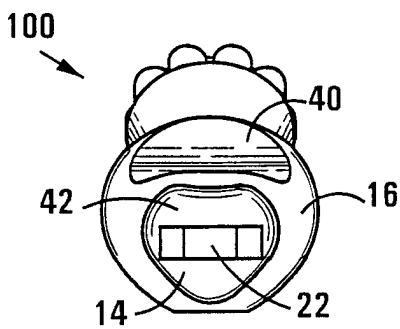

FIG 9

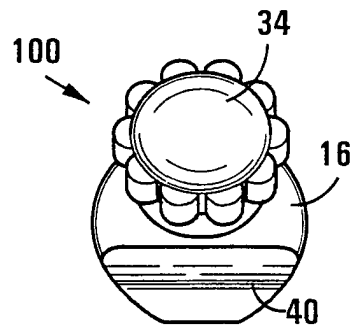

FIG 10

INTERNATIONAL SEARCH REPORT

Int. Patent Application No PCT/IB 00/00530
--

A. CLASSIFICATION OF SUBJECT MATTER IPC 7 A61M37/00 A61F13/26 According to International Patent Classification (IPC) or to both national classification and IPC
--

B. FIELDS SEARCHED Minimum documentation searched (classification system followed by classification symbols) IPC 7 A61M A61F Documentation searched other than minimum documentation to the extent that such documents are included in the fields searched
--

Electronic data base consulted during the international search (name of data base and, where practical, search terms used) EPO-Internal
--

C. DOCUMENTS CONSIDERED TO BE RELEVANT		
Category *	Citation of document, with indication, where appropriate, of the relevant passages	Relevant to claim No.
X	DE 522 404 C (H. E. HELLWIG) 8 April 1931 (1931-04-08) the whole document	1, 10, 11, 13, 16
Y	---	4-7
X	GB 2 033 754 A (KAO CORP) 29 May 1980 (1980-05-29) page 3, line 89 - line 106 figures 5, 13, 14, 20	3, 9, 11
Y	---	4-7
A	---	2, 14, 15
A	US 4 769 011 A (SWANIGER JAMES R) 6 September 1988 (1988-09-06) figure 1	8, 11
	---	-/--

<input checked="" type="checkbox"/> Further documents are listed in the continuation of box C.	<input checked="" type="checkbox"/> Patent family members are listed in annex.
--	--

* Special categories of cited documents : *A* document defining the general state of the art which is not considered to be of particular relevance *E* earlier document but published on or after the international filing date *L* document which may throw doubts on priority claim(s) or which is cited to establish the publication date of another citation or other special reason (as specified) *O* document referring to an oral disclosure, use, exhibition or other means *P* document published prior to the international filing date but later than the priority date claimed	*T* later document published after the international filing date or priority date and not in conflict with the application but cited to understand the principle or theory underlying the invention *X* document of particular relevance; the claimed invention cannot be considered novel or cannot be considered to involve an inventive step when the document is taken alone *Y* document of particular relevance; the claimed invention cannot be considered to involve an inventive step when the document is combined with one or more other such documents, such combination being obvious to a person skilled in the art. *&* document member of the same patent family
--	---

Date of the actual completion of the international search 12 July 2000	Date of mailing of the international search report 19/07/2000
--	---

Name and mailing address of the ISA European Patent Office, P.B. 5818 Patentlaan 2 NL - 2280 HV Rijswijk Tel. (+31-70) 340-2040, Tx. 31 651 epo nl, Fax: (+31-70) 340-3016	Authorized officer Sedy, R
--	--

INTERNATIONAL SEARCH REPORT

International Application No
PCT/IB 00/00530

C.(Continuation) DOCUMENTS CONSIDERED TO BE RELEVANT		
Category *	Citation of document, with indication, where appropriate, of the relevant passages	Relevant to claim No.
A	US 5 314 464 A (EASTMAN WILLIAM J ET AL) 24 May 1994 (1994-05-24) figure 1 <div style="text-align: center; margin-top: 10px;">-----</div>	9

INTERNATIONAL SEARCH REPORT

Information on patent family members

International Application No

PCT/IB 00/00530

Patent document cited in search report	Publication date	Patent family member(s)	Publication date
DE 522404	C	NONE	
GB 2033754	A	29-05-1980	
		JP 55047852 A	05-04-1980
		JP 57004258 B	25-01-1982
		JP 55063644 A	13-05-1980
		JP 57004259 B	25-01-1982
		AU 5141279 A	17-04-1980
		BE 879157 A	01-02-1980
		DE 2940022 A	30-04-1980
		FR 2437827 A	30-04-1980
US 4769011	A	06-09-1988	
		NONE	
US 5314464	A	24-05-1994	
		AU 672998 B	24-10-1996
		AU 4851693 A	26-04-1994
		CA 2144526 A	14-04-1994
		DE 69328256 D	04-05-2000
		EP 0662799 A	19-07-1995
		JP 2703115 B	26-01-1998
		JP 8500755 T	30-01-1996
		WO 9407405 A	14-04-1994