



US011575218B2

(12) **United States Patent**
Diop et al.

(10) **Patent No.:** **US 11,575,218 B2**

(45) **Date of Patent:** **Feb. 7, 2023**

(54) **CABLE SPLICE HAVING INTERLOCKING JAW MEMBERS**

(71) Applicant: **Hubbell Incorporated**, Shelton, CT (US)

(72) Inventors: **Seydou Diop**, Birmingham, AL (US); **Adrian Beau Candelaria**, Alabaster, AL (US)

(73) Assignee: **Hubbell Incorporated**, Shelton, CT (US)

(*) Notice: Subject to any disclaimer, the term of this patent is extended or adjusted under 35 U.S.C. 154(b) by 3 days.

(21) Appl. No.: **17/204,497**

(22) Filed: **Mar. 17, 2021**

(65) **Prior Publication Data**

US 2021/0296798 A1 Sep. 23, 2021

Related U.S. Application Data

(60) Provisional application No. 62/991,825, filed on Mar. 19, 2020.

(51) **Int. Cl.**
H01R 4/48 (2006.01)
H01R 4/52 (2006.01)
H01R 11/09 (2006.01)

(52) **U.S. Cl.**
CPC **H01R 4/48** (2013.01); **H01R 4/52** (2013.01); **H01R 11/09** (2013.01)

(58) **Field of Classification Search**
CPC H01R 4/52; H01R 11/09; H01R 4/4872; H01R 4/5083

See application file for complete search history.

(56) **References Cited**

U.S. PATENT DOCUMENTS

4,744,622 A	5/1988	Cherry et al.	
5,683,273 A	11/1997	Garver et al.	
7,219,399 B2	5/2007	Tamm et al.	
8,674,230 B2 *	3/2014	Hoxha	H01R 11/28 174/79
9,502,791 B2 *	11/2016	Diop	H01R 4/4872
10,411,369 B2	9/2019	Diop et al.	
10,665,966 B2	5/2020	Diop et al.	
2014/0273575 A1	9/2014	O'Sullivan	
2015/0107875 A1	4/2015	Diop et al.	
2017/0271789 A1 *	9/2017	Diop	H01R 4/52

OTHER PUBLICATIONS

PCT/US2021/022762 International Search Report and Written Opinion dated Jun. 8, 2021 (15 pages).

* cited by examiner

Primary Examiner — Ross N Gushi

(74) *Attorney, Agent, or Firm* — Michael Best & Friedrich LLP

(57) **ABSTRACT**

A cable splice includes a casing having a central portion and a first end including a first aperture. The casing defines an interior cavity. A jaw assembly is positioned in the interior cavity and moveable between a loading position and a terminated position for engaging a conductor. A biasing member biases the jaw assembly toward the terminated position. The jaw assembly includes a jaw member having a jaw body, a curvilinear projection extending from the jaw body and a curvilinear groove extending into the jaw body. The projection and groove are aligned with one another and configured to mate with a respective groove and projection of an adjacent jaw member.

19 Claims, 20 Drawing Sheets

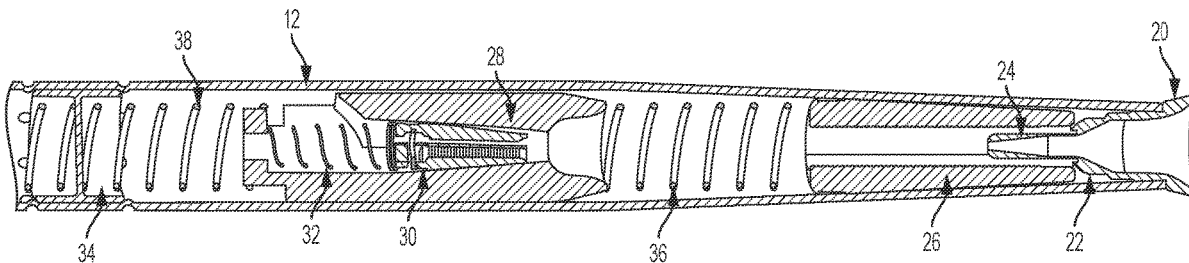

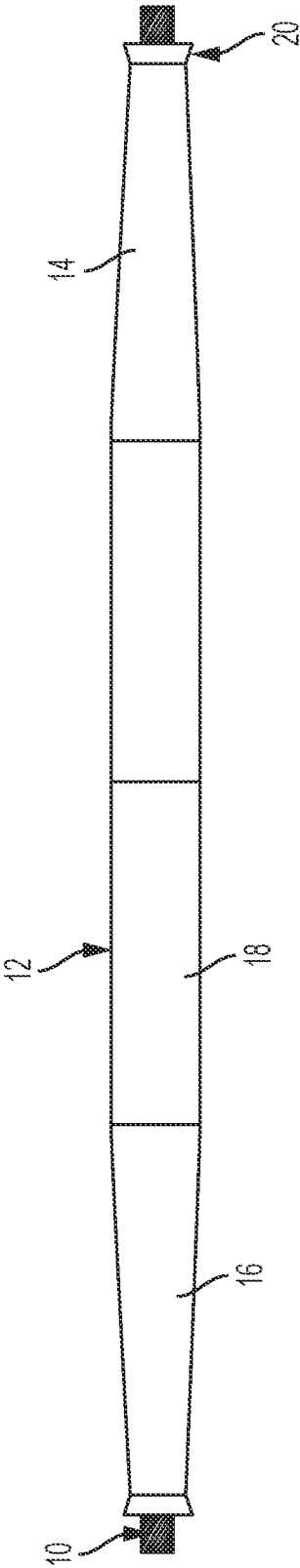

FIG. 1

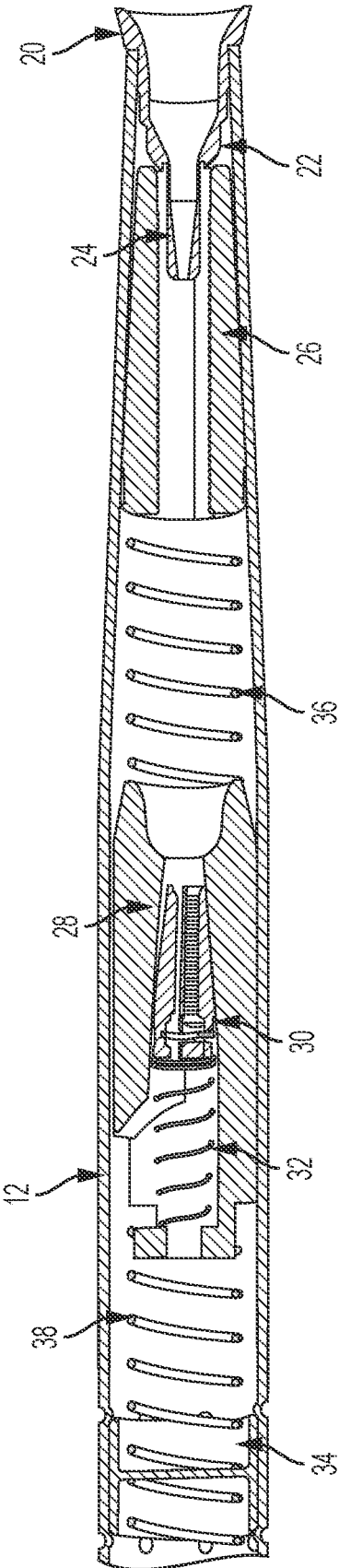

FIG. 2

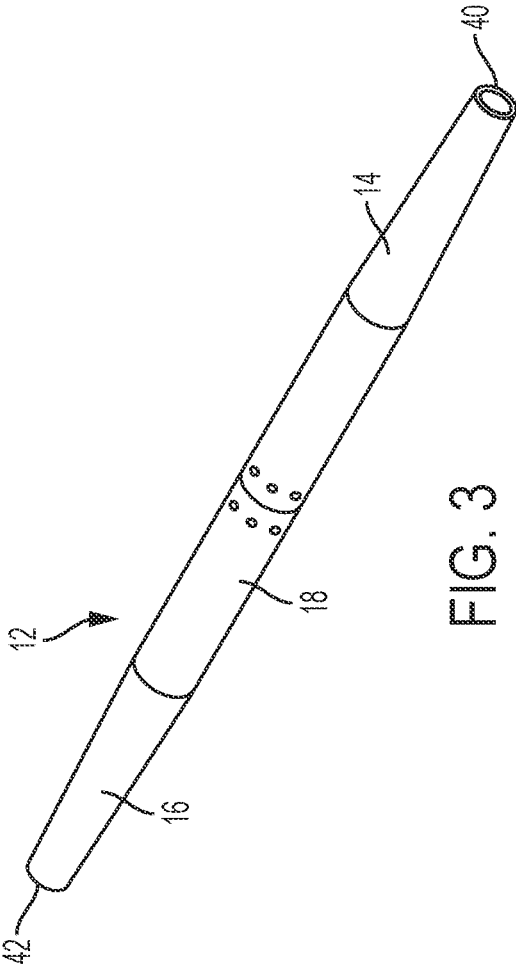

FIG. 3

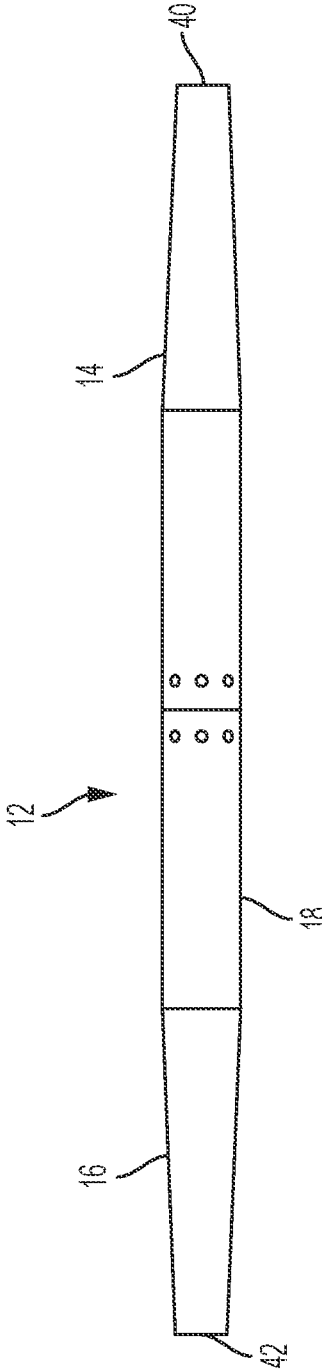

FIG. 4

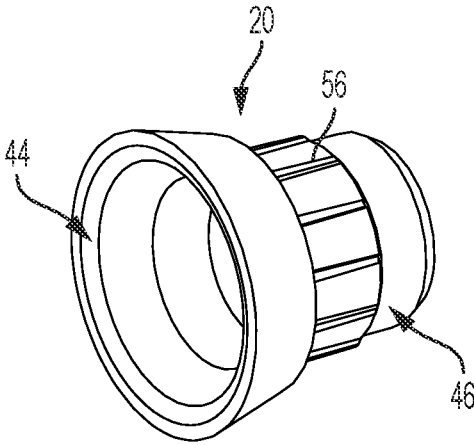

FIG. 5

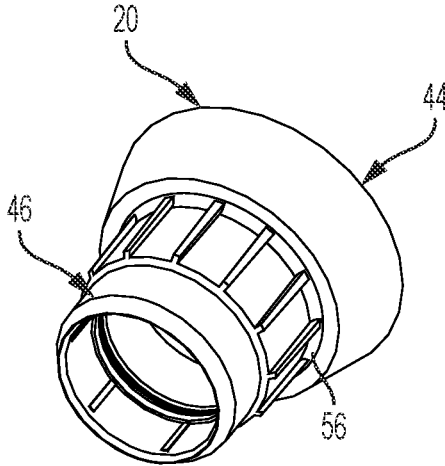

FIG. 6

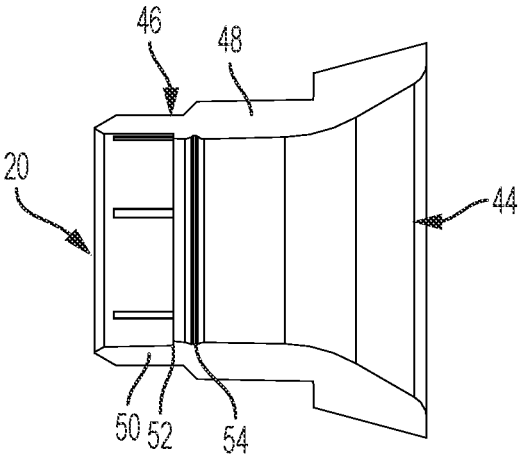

FIG. 7

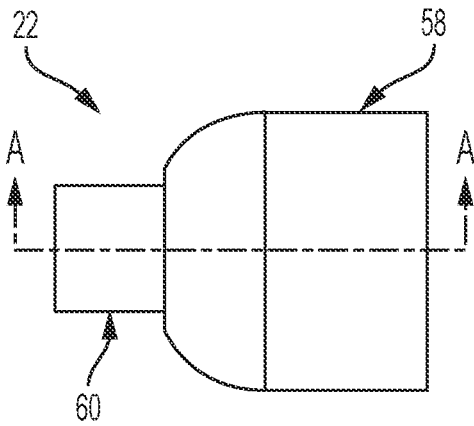

FIG. 8

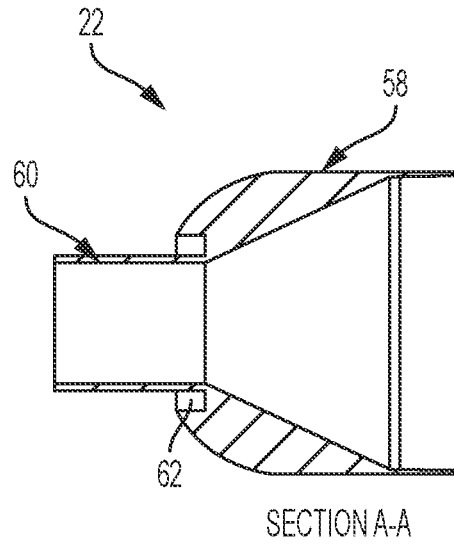

FIG. 9

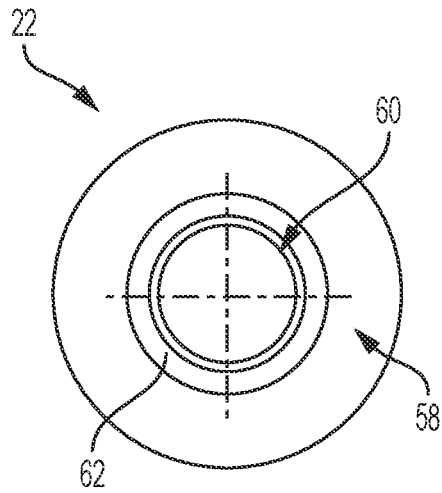

FIG. 10

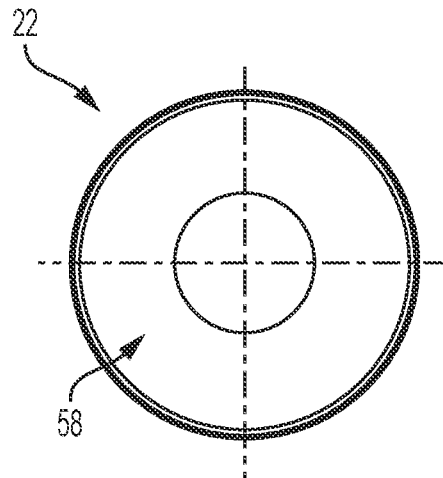

FIG. 11

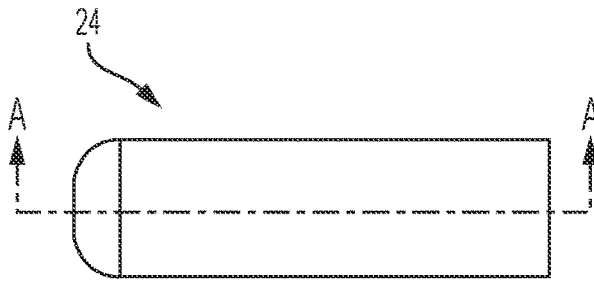

FIG. 12

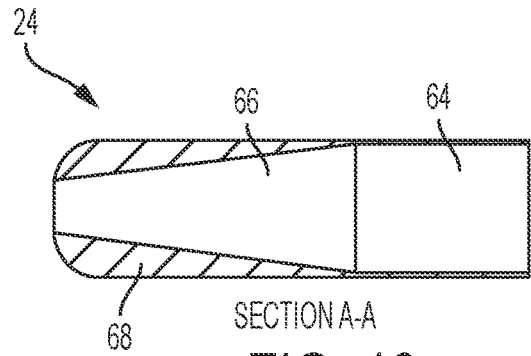

FIG. 13

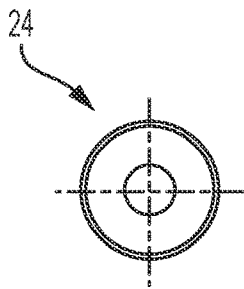

FIG. 14

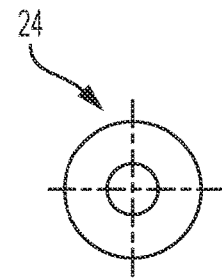

FIG. 15

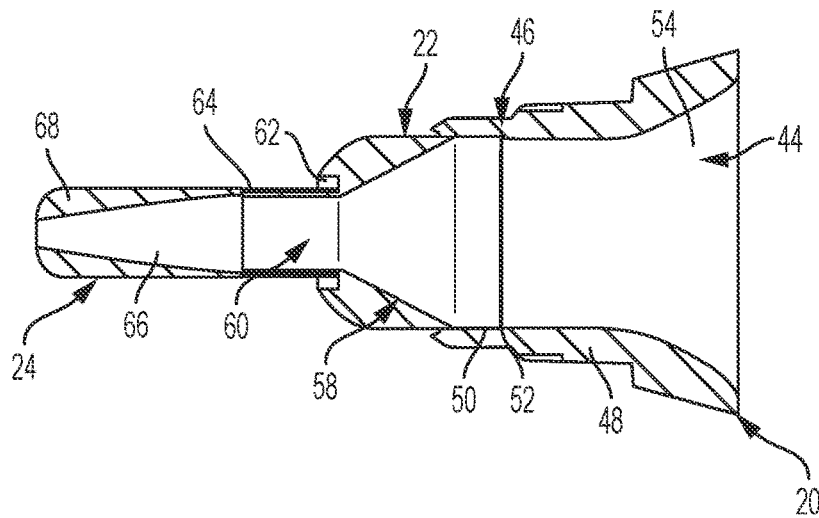

FIG. 16

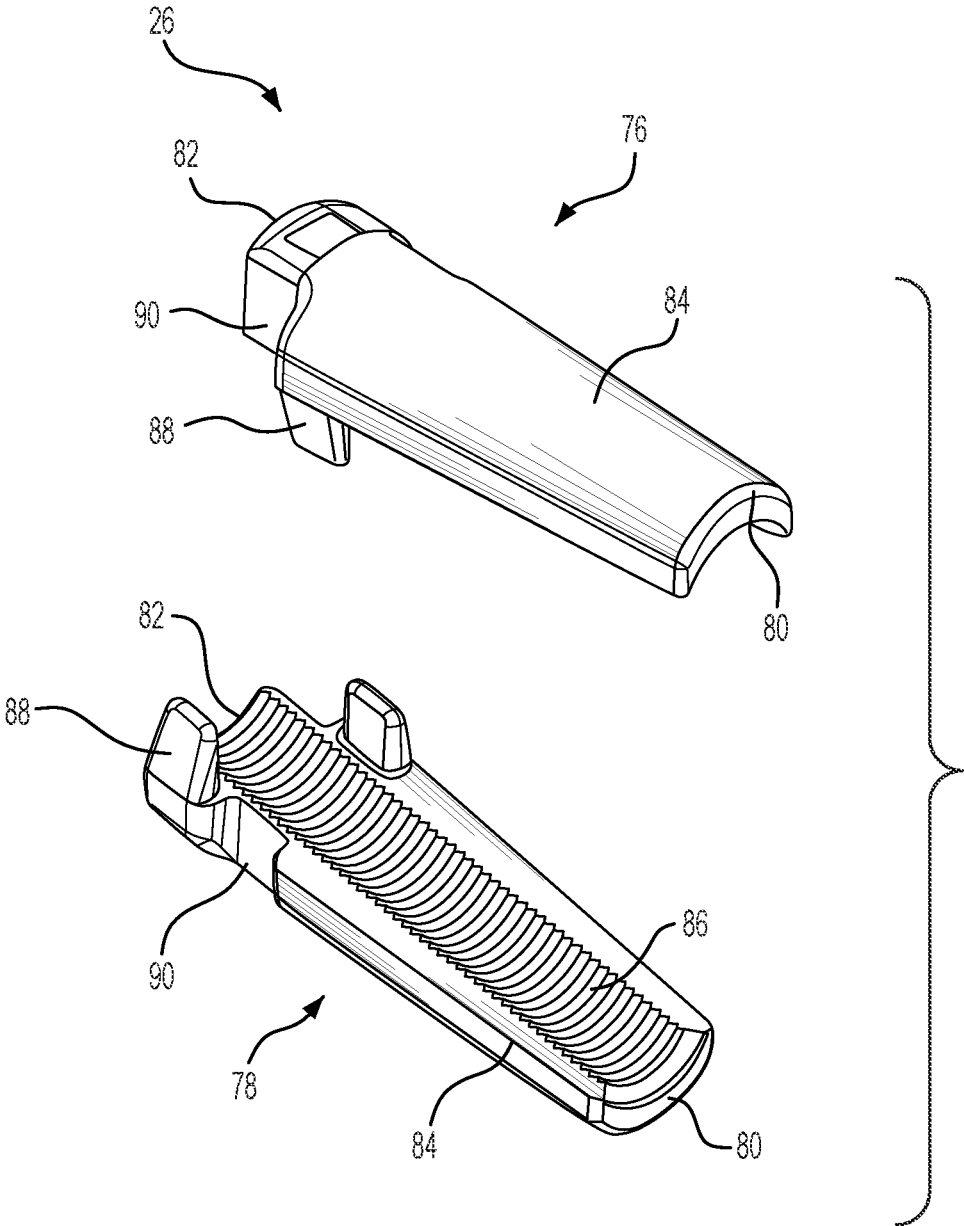

FIG. 17

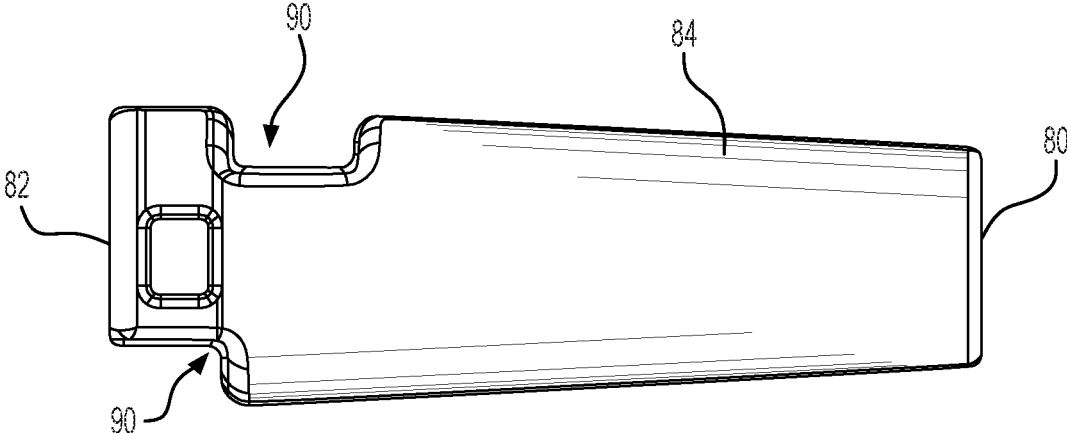

FIG. 18

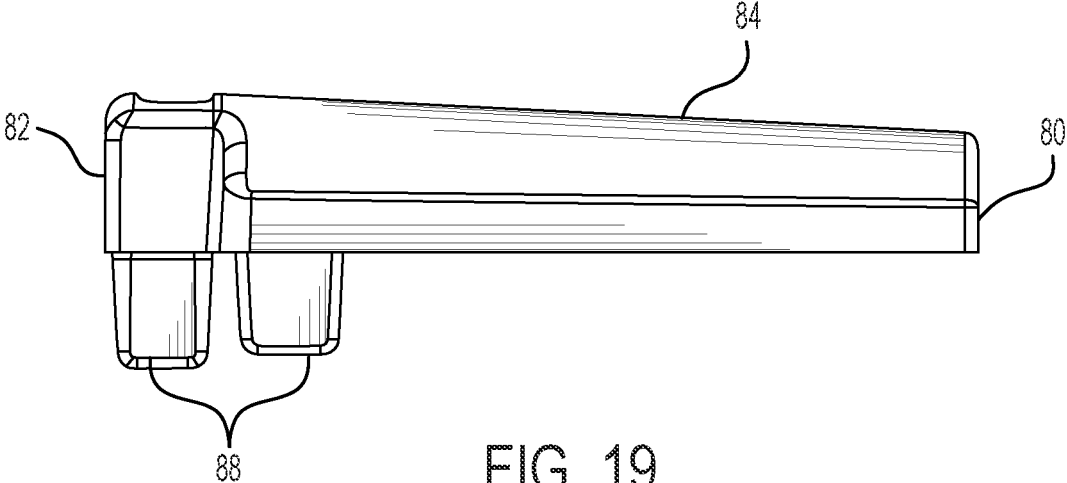

FIG. 19

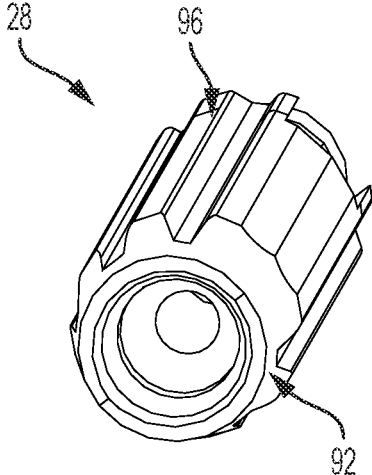

FIG. 20

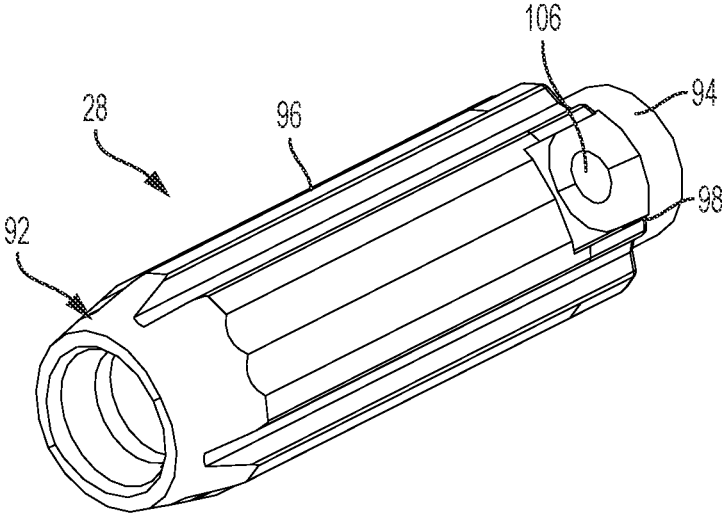

FIG. 21

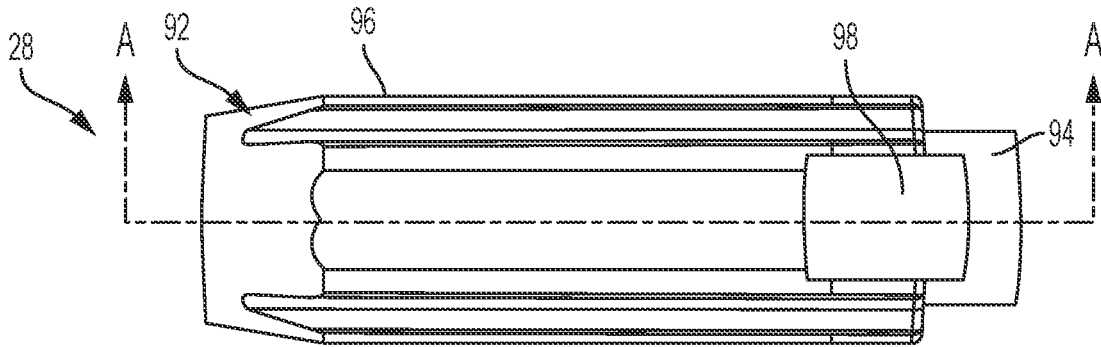

FIG. 22

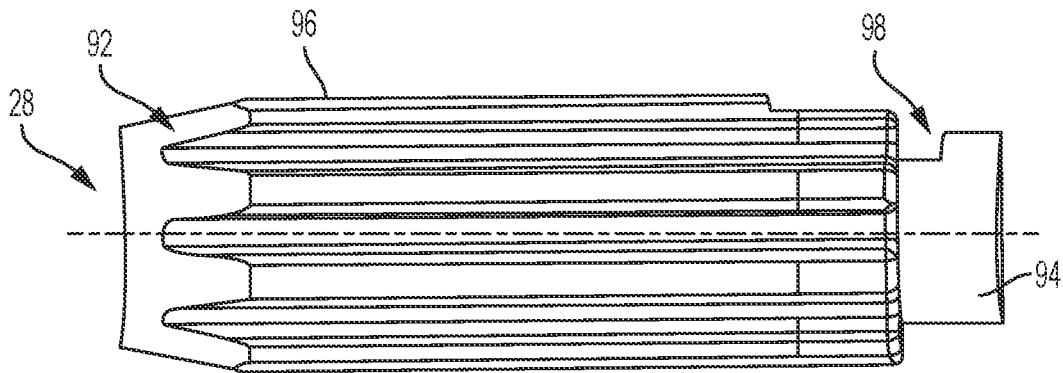

FIG. 23

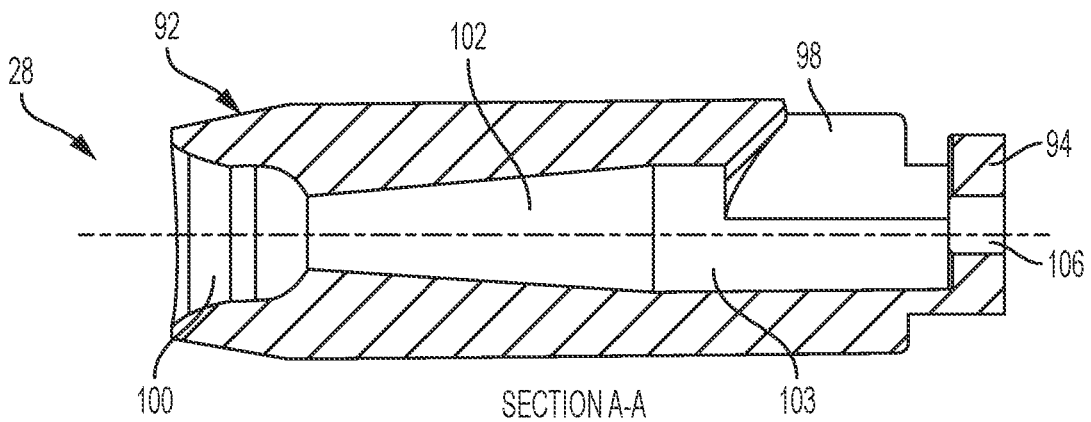

FIG. 24

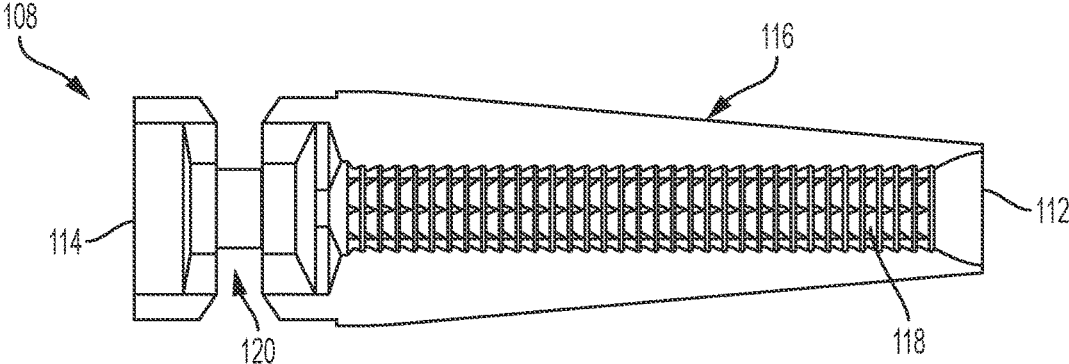

FIG. 25

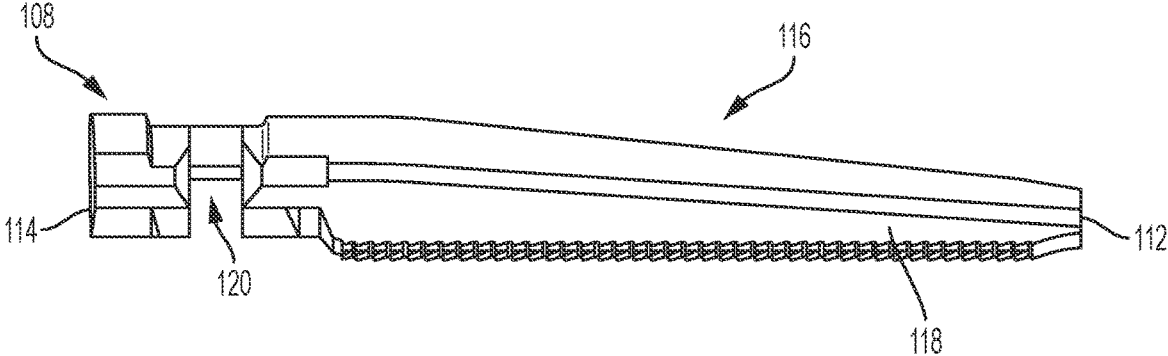

FIG. 26

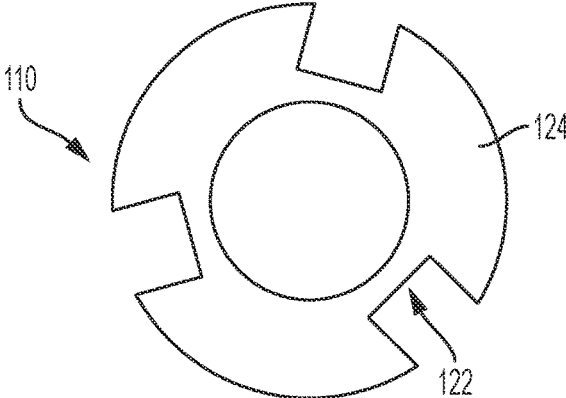

FIG. 27

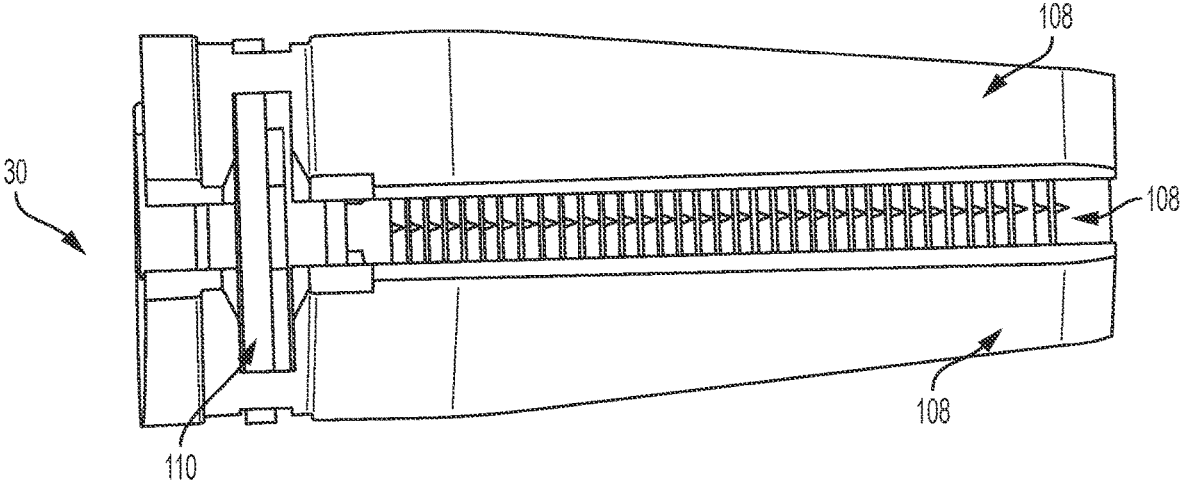

FIG. 28

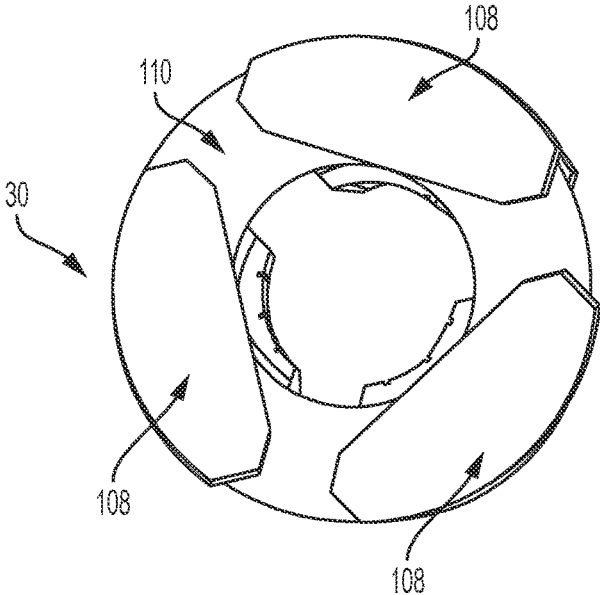

FIG. 29

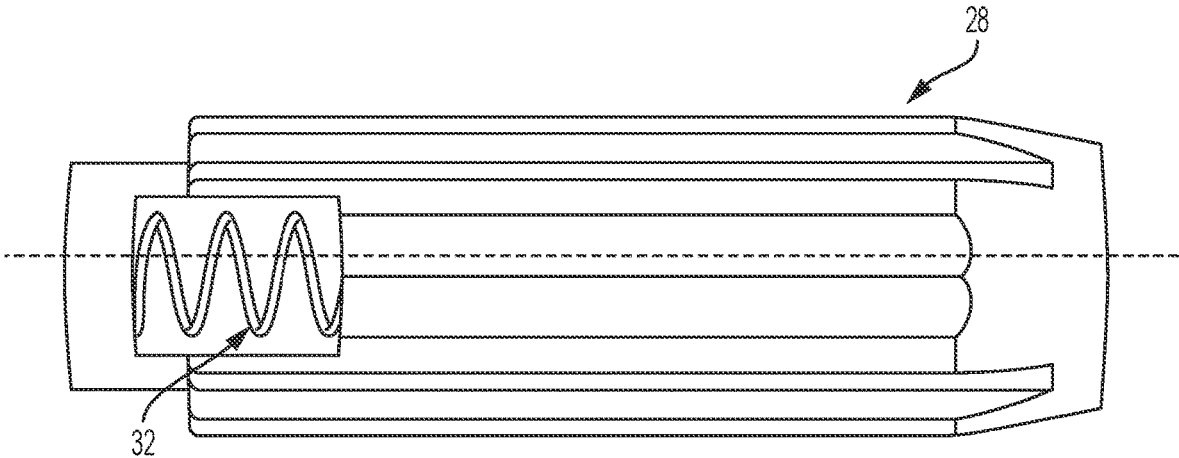

FIG. 30

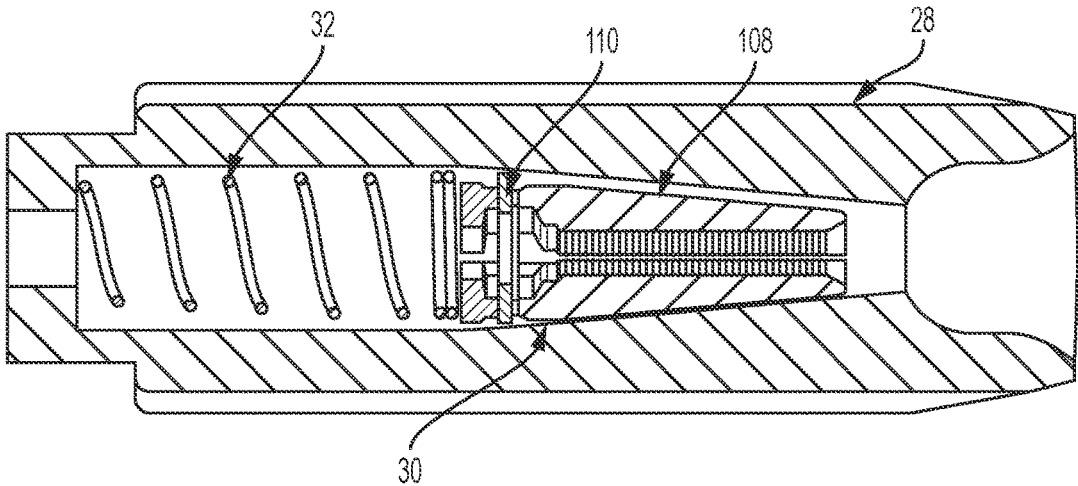

FIG. 31

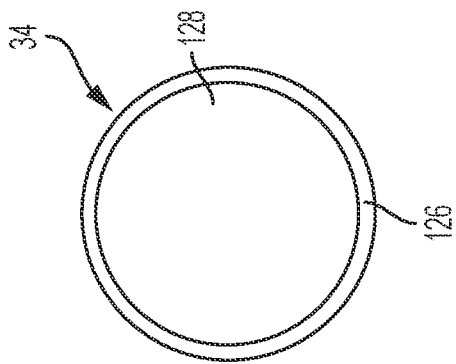

FIG. 32

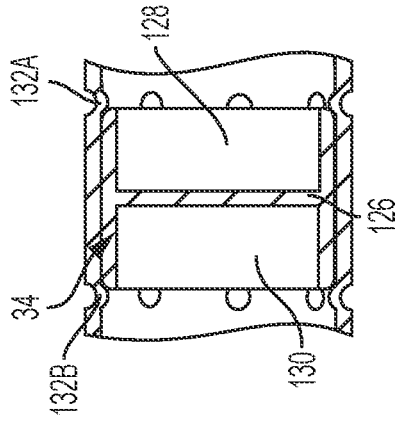

FIG. 33

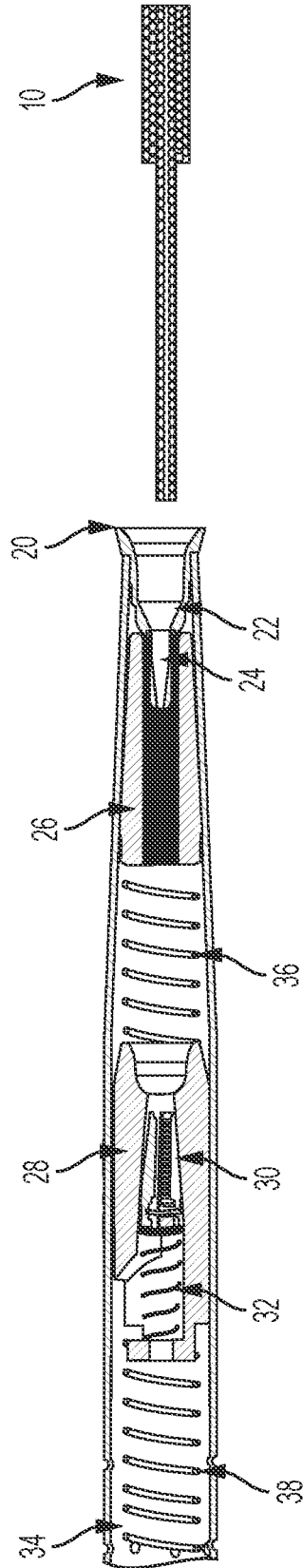

FIG. 34

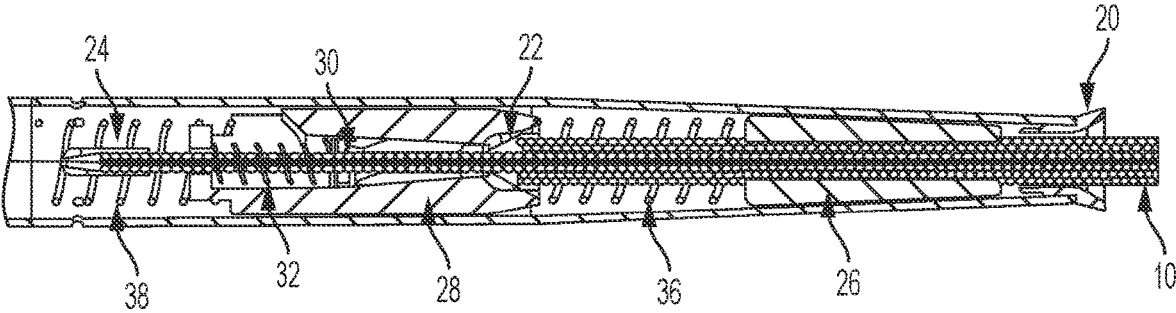

FIG. 35

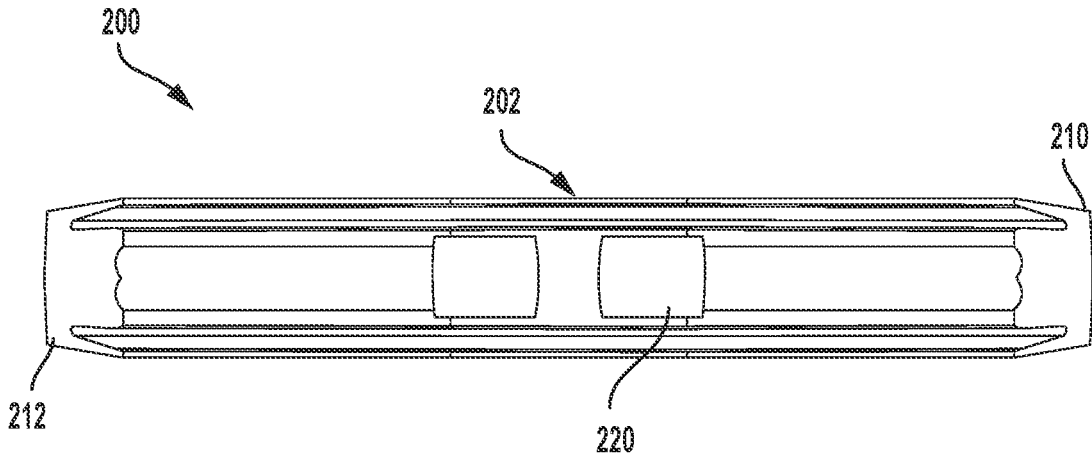

FIG. 36

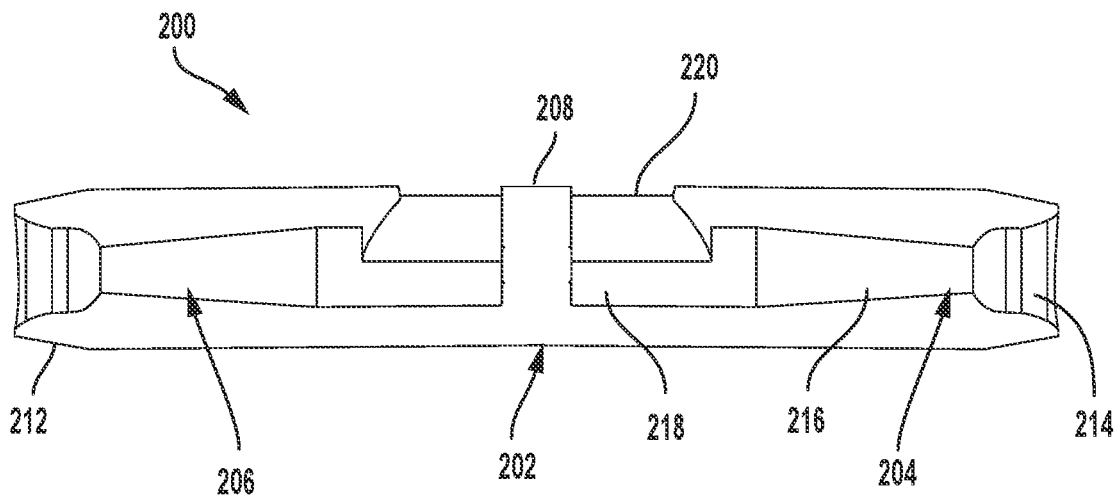

FIG. 37

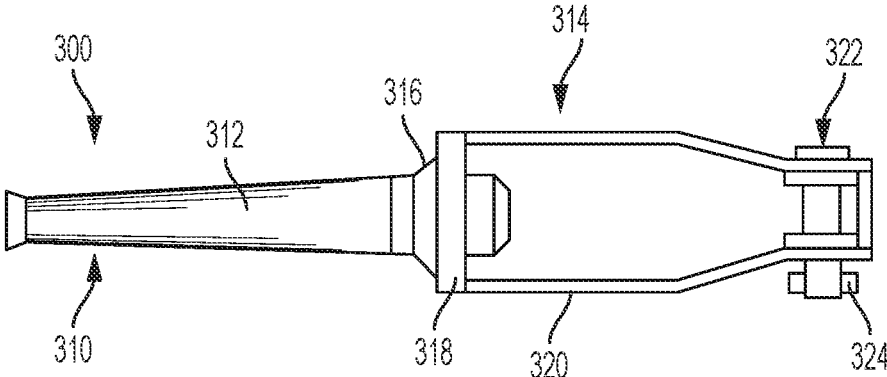

FIG. 38

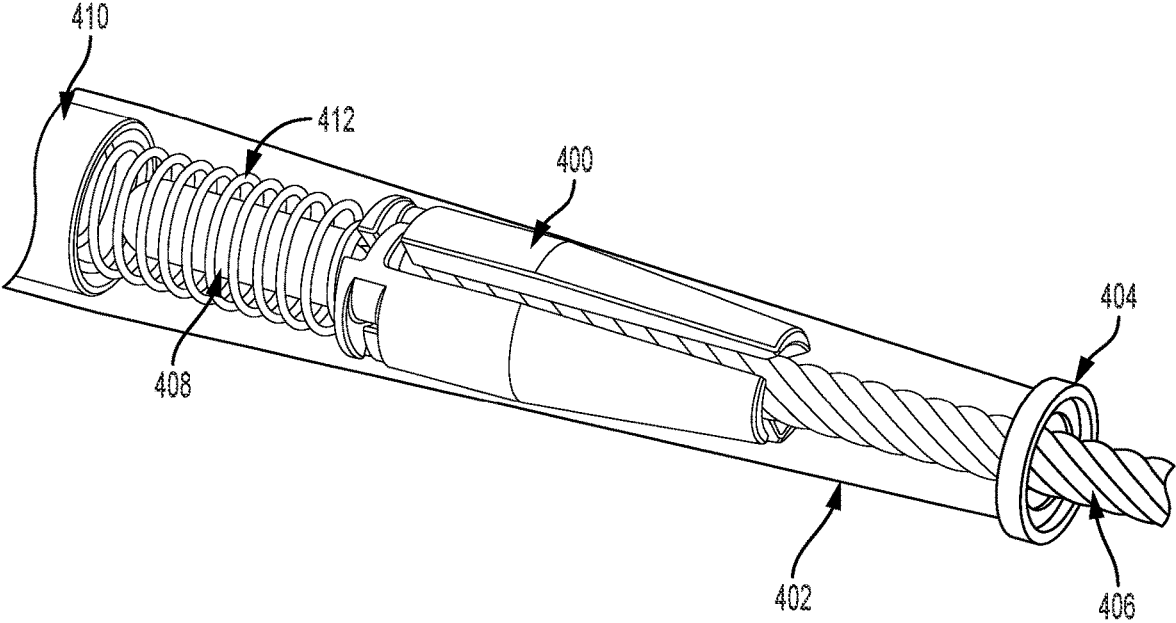

FIG. 39

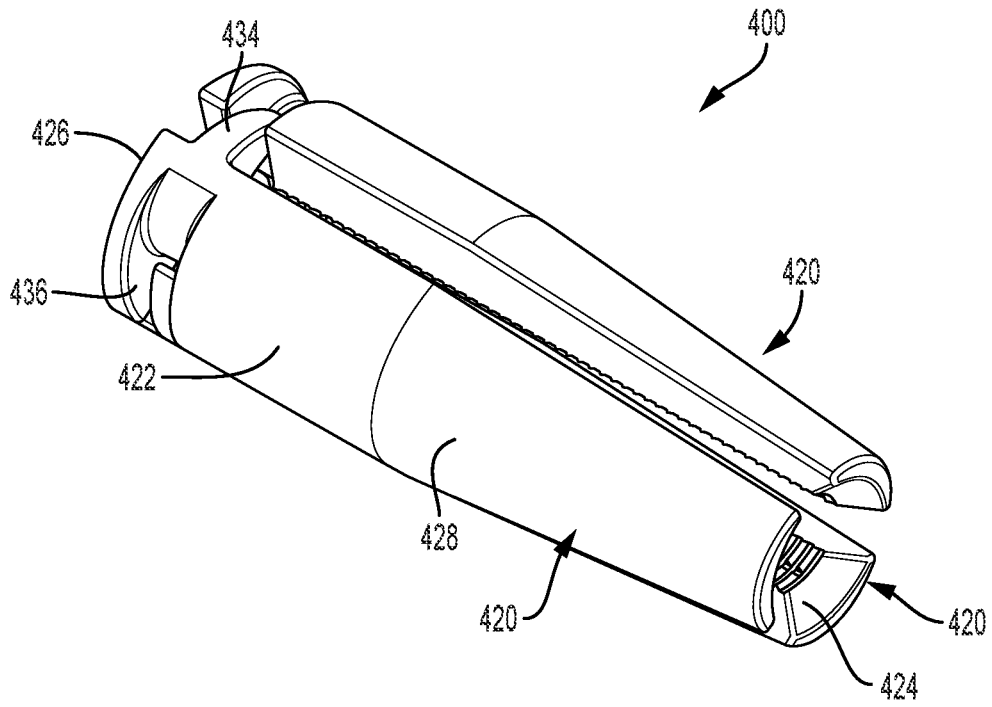

FIG. 40

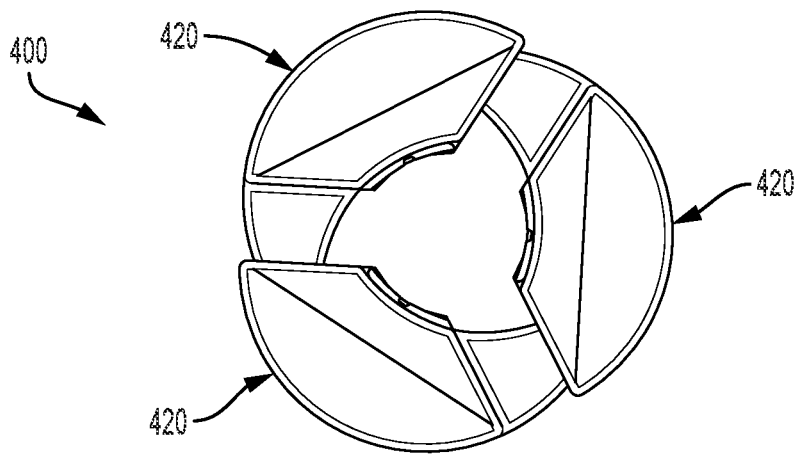

FIG. 41

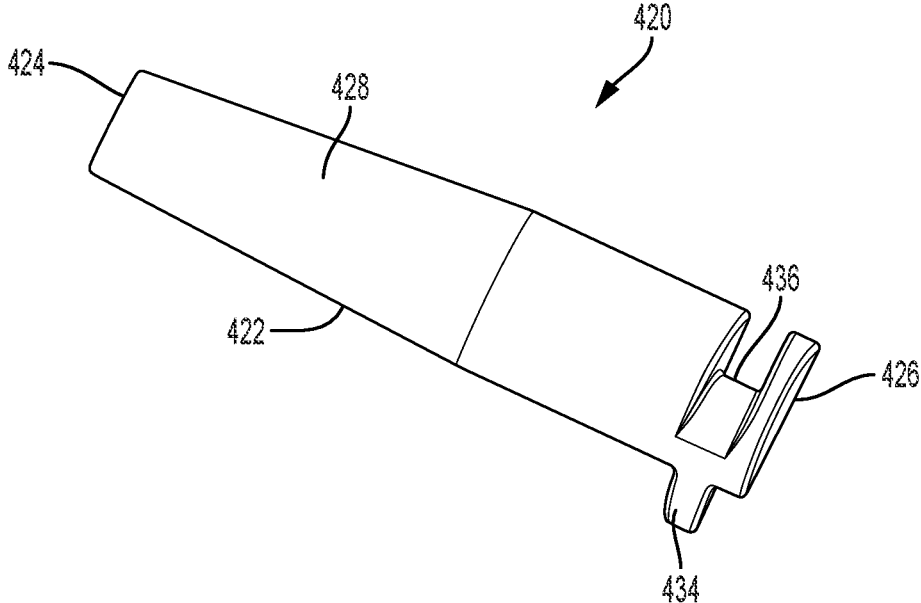

FIG. 42

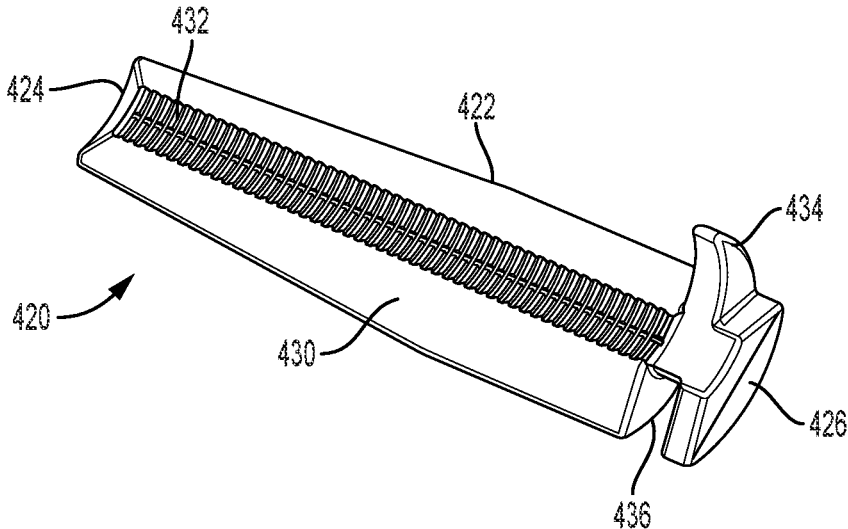

FIG. 43

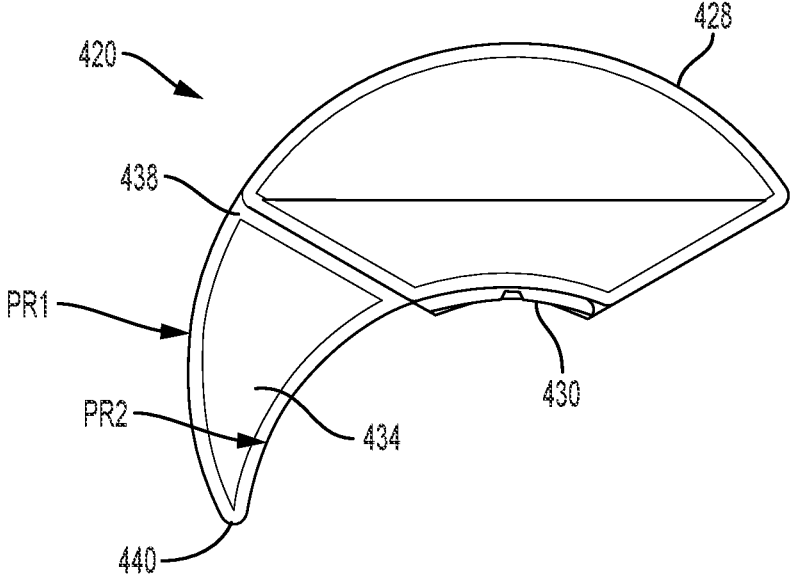

FIG. 44

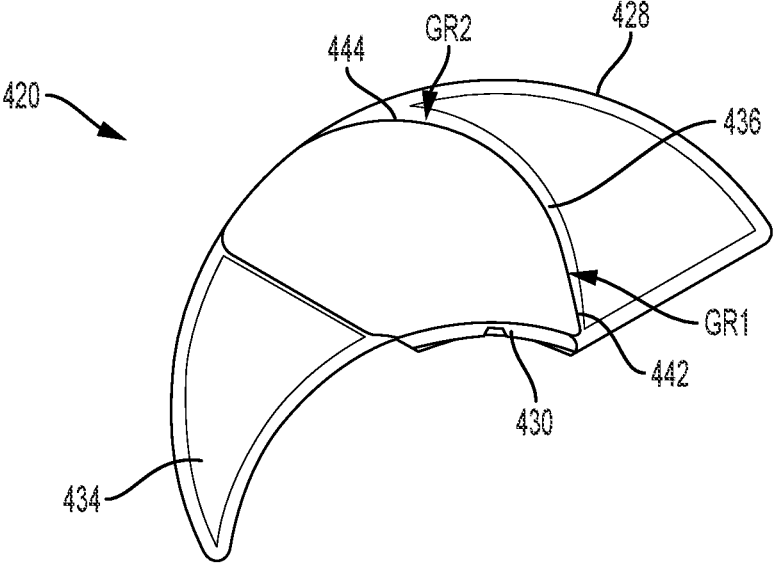

FIG. 45

1

CABLE SPLICE HAVING INTERLOCKING JAW MEMBERS

RELATED APPLICATION(S)

This application claims priority to U.S. Provisional Application Ser. No. 62/991,825, filed Mar. 19, 2020, the disclosure of which is incorporated herein by reference in its entirety and to which priority is claimed.

FIELD

The invention relates to splices for connecting first and second utility transmission line cables.

BACKGROUND

Splicing connectors may be used to join a variety of electrical conductors, including high-voltage power lines. Some splicing connectors allow a user to simply input two different conductors into the connector. Such splicing connectors, commonly referred to as automatic splices, may be used by utility linemen to quickly connect lengths of suspended cables during installation or repair of downed power lines.

An automatic splice typically includes a housing having an opening on each axial end for receiving cables. After the cables are inserted, the housing includes clamps for maintaining the cables in a relative position. The automatic splice is then capable of conducting electricity from one cable to the other. Seating the cables properly in the housing is important to ensure a secure and lasting connection. This seating is especially true in exposed cables undergoing stress from different directions, such as from wind, ice, galloping or additional loading that may occur in regular use.

Utility linemen use automatic splices in normal or emergency power restoration situations, under a variety situations and environmental conditions. Applying significant force to insert the cables or knowing if the cable has been fully inserted may be difficult for the lineman. Automatic splices typically have non-transparent casings or housings, making visual inspection of the cables positioning impossible. If a cable is not properly or fully inserted, the retaining clamps will not function as intended. Failure of a spliced connection can release live cables, risking dangerous conditions to people and property, especially in the instance of live power lines.

SUMMARY

According to various aspects, a cable splice includes a casing having a central portion and a first end including a first aperture. The casing defines an interior cavity. A jaw assembly is positioned in the interior cavity and moveable between a loading position and a terminated position for engaging a conductor. A biasing member biases the jaw assembly toward the terminated position. The jaw assembly includes a jaw member having a jaw body, a curvilinear projection extending from the jaw body and a curvilinear groove extending into the jaw body. The projection and groove are aligned with one another and configured to mate with a respective groove and projection of an adjacent jaw member.

According to various aspects, a cable splice includes a casing having a central portion and a first end including a first aperture. The casing defines an interior cavity. A first jaw is positioned in the interior cavity and moveable

2

between a loading position and a terminated position. The first jaw has a first protrusion and a first groove. A second jaw is positioned in the interior cavity and moveable between the loading position and the terminated position.

The second jaw has a second protrusion and a second groove. A third jaw is positioned in the interior cavity and moveable between the loading position and the terminated position. The third jaw has a third protrusion and a third groove. The first, second, and third jaws are positioned so that the each of the projections is mated with a respective groove.

According to certain aspects, a jaw for a utility line cable splice includes a jaw body having a front surface, a rear surface, a curved body outer surface, and a curved body inner surface. The jaw body is configured to be positioned inside of a swaged casing. A projection extends from the jaw body. The projection includes a base, a point, a curved projection outer surface, and a curved projection inner surface. A groove extends into the jaw body. The groove includes an inner end and an outer end. The groove includes a first radius of curvature and a second radius of curvature. The first radius of curvature is not equal to the second radius of curvature.

BRIEF DESCRIPTION OF THE DRAWINGS

The aspects and features of various exemplary embodiments will be more apparent from the description of those exemplary embodiments taken with reference to the accompanying drawings, in which:

FIG. 1 is a side view of an exemplary splice with inserted cables.

FIG. 2 is a sectional view of the splice of FIG. 1 without the inserted cables.

FIG. 3 is a perspective view of an exemplary casing.

FIG. 4 is sectional view of the casing of FIG. 3.

FIG. 5 is a front perspective view of an exemplary guide.

FIG. 6 is a rear perspective view of FIG. 5.

FIG. 7 is a side, sectional view of the guide of FIG. 5.

FIG. 8 is a side view of an exemplary escort cup.

FIG. 9 is a sectional view of FIG. 8.

FIG. 10 is a rear view of FIG. 8.

FIG. 11 is a front view of FIG. 8.

FIG. 12 is a side view of an exemplary pilot cup.

FIG. 13 is a sectional view of FIG. 12.

FIG. 14 is a front view of FIG. 12.

FIG. 15 is a rear view of FIG. 12.

FIG. 16 is a sectional view of the exemplary guide, escort cup, and pilot cup.

FIG. 17 is an exploded perspective view of an exemplary jaw assembly.

FIG. 18 is a top view of the jaw member of FIG. 17.

FIG. 19 is a side view of the jaw member of FIG. 17.

FIG. 20 is front perspective view of an exemplary carrier.

FIG. 21 is side perspective view of FIG. 20.

FIG. 22 is a top view of FIG. 20.

FIG. 23 is a side view of FIG. 20.

FIG. 24 is a sectional view of FIG. 23.

FIG. 25 is a bottom view of an exemplary jaw member of the second jaw assembly.

FIG. 26 is a side view of FIG. 25.

FIG. 27 is front view of an exemplary retainer of the second jaw assembly.

FIG. 28 is a side view of the exemplary second jaw assembly.

FIG. 29 is a front view of FIG. 28.

3

FIG. 30 is a top view of the exemplary carrier and second jaw assembly.

FIG. 31 is a sectional view of FIG. 30.

FIG. 32 is a front view of an exemplary center stop.

FIG. 33 is a sectional view of the center stop in the casing.

FIG. 34 is a sectional view of the exemplary splice prior to cable insertion.

FIG. 35 is a sectional view of the exemplary splice after the cable has been fully inserted.

FIG. 36 is a top view of a dual chamber carrier.

FIG. 37 is a sectional view of the dual chamber carrier of FIG. 36.

FIG. 38 is a side view of an exemplary embodiment of a dead-end splice.

FIG. 39 is a partial view of a cable splice having another embodiment of a jaw assembly.

FIG. 40 is a perspective view of the jaw assembly of FIG. 39.

FIG. 41 is a rear view of FIG. 40.

FIG. 42 is top perspective view of a jaw member of FIG. 40.

FIG. 43 is a bottom perspective view of FIG. 42.

FIG. 44 is a rear view of FIG. 42.

FIG. 45 is a sectional view of FIG. 44 showing the groove.

DETAILED DESCRIPTION OF EXEMPLARY EMBODIMENTS

Various exemplary embodiments are directed to a cable splice for use with multi-strand cables 10. Multi-strand cables 10 can include an outer layer that surrounds an inner layer. In an exemplary embodiment, the outer layer is made from a first material, for example aluminum strands, while the inner layer is made of a second material, for example steel strands.

In accordance with an exemplary embodiment, a splice includes a casing 12 having a first side and a second side with each side having a set of components. The casing 12 includes a substantially tubular body having a first casing end 14 and a second casing end 16, at least a portion of which tapers to the respective end of the casing 12. The casing surrounds an internal cavity that can be divided into a first chamber, a second chamber, and a central region. The components in the second chamber may be identical to the first. Certain embodiments, however, may utilize different components in the second chamber. The present invention may also be utilized as a dead-end type connector that has only a single chamber. Although the drawings depict the first and second chambers having identical components, only the components of the first chamber may be discussed in certain instances for brevity.

In an example embodiment, the components can include: a guide assembly having a guide 20, an escort cup 22, and a pilot cup 24; a first clamp in the form of a first jaw assembly 26; a carrier assembly having a carrier 28, a second clamp in the form of a second jaw assembly 30, and a biasing member 32; and a center stop 34. A biasing member 36 is positioned between the carrier assembly and the first jaw assembly 26 and another biasing member 38 is positioned between the center stop 34 and the carrier assembly.

FIGS. 3 and 4 show an exemplary casing 12 having a swaged, tubular body, although a variety of shapes may be used having any number of straight or curved sides. The casing 12 includes a first casing aperture 40 and a second casing aperture 42. The first and second casing apertures 40, 42 may include a chamfered or beveled edge to allow for

4

easy installation of additional components. The first casing end 14 tapers from the central region 18 to the first casing aperture 40, forming a first frusto-conical member defining the first chamber. The second casing end similarly tapers from the central region 18 to the second casing aperture 42, forming a second frusto-conical member defining the second chamber. Various components are housed in the first and second chambers as discussed below. Only the components of the first chamber may be discussed in certain instances for brevity.

The guide 20 can be positioned so that it has a portion positioned outside of the casing 12 and a portion extending into the casing 12 through the first casing aperture 40. The guide 20 receives and guides a cable 10 being inserted into the splice. The guide 20 helps prevent strands of the cable from splaying, allowing a quick, easy, and clean insertion of a length of cable. In certain embodiments, the guide 20 can be configured to exit the casing to show that one or more of the jaws are properly engaged with a conductor. An example of such a guide 20 is disclosed in U.S. Pat. No. 10,498,052, the disclosure of which is incorporated herein by reference.

As best shown in FIGS. 5-7, the guide 20 includes a receiving end 44 having a funnel-shaped body surrounding an aperture and a cylindrical shaft 46 extending from the receiving end 44. The receiving end 44 is positioned outside of the casing 12, while the shaft 46 extends into the first chamber. In alternative exemplary embodiments, the receiving end 44 and the shaft 46 are positioned either partly or entirely, in the first chamber. The guide 20 can also act as a visual indicator that displays information to a user. For example, the receiving end 44 and/or shaft 46 can include a colored portion, with the color being indicative of a type of conductor used for the splice.

The receiving end 44 may be a variety of shapes and sizes, depending on relevant factors such as the cable shape and size. The interior surface of guide 20 can include one or more curvilinear transitions between the outer edge of the receiving end 44 and the shaft 46. In an exemplary embodiment where there is more than one curved transition, the transitions can have a different radius of curvature. For example a transition proximate the outer edge can have a first radius of curvature while a transition proximate the shaft 46 can have a second radius of curvature that is larger than the first radius of curvature.

The shaft 46 has a first inner surface defining a first section 48 with a first diameter and a second inner surface defining a second section 50 with a second diameter. The diameter of the first section 48 is less than the diameter of the second section 50, forming a ledge 52 at the transition between the two. The first section 48 includes a groove 54. The outer surface of the shaft 46 includes one or more ribs 56. The ribs 56 engage the inner casing surface providing a secure fit between the casing 12 and the guide 20, assisting in retaining the guide 20 in position and preventing unwanted movement relative to the casing 12.

An exemplary embodiment of an escort cup 22 is shown in FIGS. 8-11. The escort cup 22 is positioned behind the guide 20 to receive the conductor 10 as it is inserted into the casing 12. The escort cup 22 can be either connected to, adjacent to, or spaced laterally from the guide 20. After a cable is inserted into and passes through the guide 20, it enters the escort cup 22 to travel through the first jaw assembly 26. At least a portion of the escort cup 22 can be initially positioned in the first jaw assembly 26.

The escort cup 22 includes a front end 58 having an opening for receiving a cable and a rear shaft 60. The front end 58 has a substantially cylindrical outer surface and an

inner surface having a tapered section forming a frusto-conical region. The tapered section allows for proper engagement of different sized conductors. A groove 62 is formed around the rear shaft. The rear shaft 60 is hollow with a substantially cylindrical configuration. The escort cup 22 helps to keep the outer strands of the cable 10 from splaying.

An exemplary embodiment of a pilot cup 24 is shown in FIGS. 12-15. The pilot cup 24 is positioned behind the guide 20 and the escort cup 22 to receive the conductor 10 as it is inserted into the casing 12. The pilot cup 24 can be either connected to, adjacent to, or spaced laterally from the escort cup 22. After a cable 10, or a portion thereof, is inserted into and passes through the guide 20 and the escort cup 22, it enters the pilot cup 24 to travel through the first jaw assembly 26. At least a portion of the pilot cup 24 can be initially positioned in the first jaw assembly 26.

According to the exemplary embodiment, the pilot cup 22 has a cylindrical outer surface with an open first end having a first diameter and an open second end having a second diameter less than the first diameter. In alternative embodiments, a variety of shapes, sizes, and configurations may be used. The pilot cup 24 has a first inner surface surrounding a first chamber 64 with a first diameter proximate to the first end and a tapered second inner surface surrounding a second chamber 66 with a varying diameter proximate to the second end. The tapered second chamber 66 allows for proper engagement of different sized conductors. The diameter of the first chamber 64 is greater than the diameter of the second chamber 66, resulting in the pilot cup 24 having a thicker, inner rear wall 68. When the pilot cup 24 is positioned in the first jaw assembly 26, the thicker rear wall 68 provides additional support against the force exerted by the first jaw assembly 26 on the pilot cup 24, helping to prevent the pilot cup 24 from becoming crushed, deformed, or dislodged. The pilot cup 24 helps to keep the inner strands of the cable 10 from splaying.

As best shown in FIG. 16, in an initial or loading position, the guide 20, the escort cup 22, and the pilot cup 24 are connected to form a guide assembly. The escort cup 22 is initially positioned at least partially inside of the second section of the guide 20, with a front end of the escort cup engaging the ledge 52. The rear shaft 60 of the escort cup 22 is at least partially positioned inside of the pilot cup 24 so that a portion of the pilot cup 24 is received in the outer groove 62. As a cable 10 is inserted, the escort cup 22 and pilot cup 24 disengage from the guide 20, traveling through the first jaw assembly 26. In some embodiments, the position and spacing of the guide 20, escort cup 22, and the pilot cup 24 can be varied.

The first jaw assembly 26 is positioned between the guide assembly and the first outer biasing member 36. As best shown in FIGS. 17-19, the first jaw assembly 26 includes an upper jaw member 76 and a lower jaw member 78. Though two jaw members 76, 78 are shown in this exemplary embodiment, one jaw member or more than two jaw members may also be used. Certain embodiments may utilize other cable retainers, instead of, or in combination with, the jaw members 76, 78, as would be understood by one of ordinary skill in the art.

The upper jaw member 76 and the lower jaw member 78 are substantially identical as shown in FIG. 17, and the same reference numbers will be used for like parts in describing the jaw members 76, 78. The jaw members 76, 78 have a front jaw surface 80, a rear jaw surface 82, and a jaw body 84 extending therebetween. The jaw body 84 has an arcuate outer surface and an inner surface. At least a portion of the

jaw body 84 has a semi-funnel-shape, tapering towards the front jaw surface 80. This taper is similar to or corresponds to the taper of the inner casing surface, allowing the jaw members 76, 78 to slide within the first chamber. At least a portion of the jaw body 84 inner surface contains a series of teeth 86. The teeth 86 may have any shape, pitch, length, width, or spacing. In the exemplary embodiment, the teeth 86 extend from the inner surface at an angle towards the rear jaw surface 82.

The jaw members 76, 78 include one or more radially extending projections 88 and one or more corresponding openings 90. The projections 88 and openings 90 may have a variety of sizes or shapes. The projections 88 and openings 90 are staggered, so that a single part may be used for the upper jaw member 76 and the lower jaw member 78. When placed together, the projections 88 from the upper jaw member 76 will mate with the openings 90 of the lower jaw member 78 and vice versa. This mating relationship couples the upper jaw member 76 to the lower jaw member 78 to prevent one jaw member from moving axially relative to the other jaw, ensuring substantially uniform axial movement between the jaw members 76, 78. The projections 88 extend radially inwardly and have a length preventing disengagement as the jaw members 76, 78 are moved radially away from one another by being pushed towards the central region 18, but also prevents the projections 88 from interfering with movement of the jaw members 76, 78 as they are biased towards the first casing end 16 by extending through the openings 90 and contacting the inner casing surface 42.

According to an exemplary embodiment, the biasing member 36 has a first end for contacting the rear jaw surface 82 and a second end for contacting the carrier 28. In the exemplary embodiment shown, the biasing member 36 is a coil spring, although the biasing member 20 can be other devices or materials. The outer diameter, wire diameter, pitch, length and material type of the spring may be varied depending on the application.

FIGS. 20-24 show an exemplary embodiment of the carrier 28. The carrier 28 has a body surrounding an interior with a front section facing the first aperture 40 and a second end facing the center stop 34. The body has a substantially tubular configuration with a nose 92, a back wall 94, and one or more ridges 96. A window 98 is formed near the back wall 94.

In an exemplary embodiment, the interior includes a first region 100, a second region 102, and a third region 103. The first region 100 includes an opening 100 for receiving the escort cup 22. Although a bell-shaped opening is shown, the configuration of the open can vary, for example to accommodate escort cups 22 having different sizes and shapes. The second region 102 has a frusto-conical shape that widens from the first region 100 to the third region 103. The third region 103 has a substantially cylindrical configuration and is in communication with the window 98. An aperture 106 is provided in the back wall 94.

The second jaw assembly 30 is positioned in the interior of the carrier 28. In an exemplary embodiment, the second jaw assembly 30 includes three jaw members 108 and a retainer 110. The jaw members 108 have a front jaw surface 112, a rear jaw surface 114, and a jaw body 116 extending therebetween. The jaw body 116 has an arcuate outer surface and an inner surface. At least a portion of the jaw body 116 angles or tapers towards the front jaw surface 112, allowing the jaw member 108 to move or slide within the carrier 28. At least a portion of the jaw body 116 inner surface contains a series of teeth 118. The teeth 118 may have any shape, pitch, length, width, or spacing. First and second slots 120

are formed in the jaw body 116 to receive the retainer 110. The retainer 110 has three slots 122 configured to mate with the slots 120 in the jaw member 108 and three curved sections 124 having an outer edge that substantially aligns with the outer edge of the jaw body 116 to give the assembly a substantially circular configuration as shown in FIG. 29. As shown in FIGS. 30 and 31, the second jaw assembly 30 and the inner biasing member 32 are positioned in the interior of the carrier 28. The second jaw assembly 30 and the biasing member 32 can be loaded into the carrier 28 through the carrier window 98.

FIGS. 32 and 33 show an exemplary embodiment of a center stop 34. The center stop 34 has a center wall 126, a first opening 128, and a second opening 130. The first opening 128 receives a second end of the second outer biasing member 38 and at least partially encloses a portion of the biasing member 38. The partial enclosure helps maintain the biasing member 38 in place, preventing it from becoming dislodged and failing to exert proper biasing force in the correct direction. According to various exemplary embodiments, the center stop 34 is substantially cylindrical having corresponding cylindrical first and second openings 128, 130, although any shape, or combination of shapes, of center stop 34 and first and second openings 128, 130 may be used. The center stop 34 is held in position in the central chamber by a first and second set of dimples 132A, 132B.

In an alternative embodiment, the carrier 28 can be a dual chamber carrier 200 that includes a first side having the configuration shown in FIGS. 30 and 31 and a second side having a substantially identical opposite facing configuration. In this embodiment, the center stop 34 and the biasing members 38 can be removed. The first and second sides of the dual chamber can be separated by a single back wall 94 or other structure. In an exemplary embodiment, the structure separating the first and second sides can be configured to interface with the first and second set of dimples 132A, 132B to hold the carrier in place. An example of the dual chamber carrier is shown in FIGS. 36 and 37.

For example, the dual chamber carrier 200 has a body 202 surrounding a first interior 204 and a second interior 206. The first interior 204 and the second interior 206 are separated by a center wall 208. The center wall 208 can be closed as shown in FIG. 38 or include a through opening as shown in FIG. 24. The body 202 has a substantially tubular configuration with a first nose 210 facing the first aperture 40 and a second nose 212 facing the second aperture 42.

The first interior 204 includes a first region 214, a second region 216, and a third region 218. The first region 214 includes an opening for receiving the escort cup 22. Although a bell-shaped opening is shown, the configuration of the open can vary, for example to accommodate escort cups 22 having different sizes and shapes. The second region 216 has a frusto-conical shape that widens from the first region 214 to the third region 218. The third region 218 has a substantially cylindrical configuration and is in communication with a window 220. The second interior 206 has an opposite configuration. A second jaw assembly 30 is positioned in the first interior 204 and the second interior 206 as with the single chamber carrier 28 described above.

FIG. 34 shows an exemplary embodiment of the splice in the initial, or loading, position. The guide 20 extends into the casing 12, the escort cup 22 is positioned in the guide 22, and the pilot cup 24 is connected to the escort cup 22. A portion of the pilot cup 24 and the escort cup 22 are positioned in the first jaw assembly 26, for example between the upper and lower jaw members 76, 78. The position of the escort cup 22 and the pilot cup 24 prevents the upper jaw member 76 and

the lower jaw member 78 from moving closer together and prevents them from moving towards the first aperture 40, holding the jaw assembly 26 open to receive a cable 10. In this position the jaw assembly 26 compresses the biasing member 36 in a loading position.

With the automatic splice in the initial, or loading, position, a first cable 10 and a second cable 10 may be loaded into respective ends of the casing 12. In an exemplary embodiment, a portion of the outer layer of the cable is stripped to expose the inner layer. The guide 20 receiving end 44 acts to contain the strands of the cable 10 and guide them into and through the respective first casing aperture 40.

During insertion the inner layer of cables 10 pass through the escort cup 22 and into the pilot cup 24. The inner layer of the cable 10 engages the pilot cup 24 and the outer layer of the cable 10 engages the escort cup 22. Both the escort cup 22 and pilot cup 24 have tapered interior portions to engage different sized cables 10.

After the cable 10 fully engages the pilot cup 24, the exertion of axial pressure by a user pushes the pilot cup 24, the escort cup 22, and the cable 10 through the first jaw assembly 26. After the escort cup 22 and the pilot cup 24 clear the first jaw assembly 26, the biasing member 36 will push the jaw assembly 26 toward the first aperture 40 to engage the outer layer of the cable 10. As the first jaw assembly 26 moves forward, the tapered jaw body 84 slides along the tapered inner casing surface, forcing the upper jaw 76 and the lower jaw 78 radially closer to one another. The cable 10 may still be able to move toward the center of the splice, with the first jaw members 26 having angled teeth 86 allowing the cable 10 to slide along the teeth 86 toward the center of the splice but resisting movement in the opposite direction.

Because the pilot cup 24 is already positioned in the first jaw assembly 26, the user need not exert substantial force to open the jaw assembly 26 or load the biasing member 36. The rounded outer edge also helps to move the escort cup 22 through the first jaw assembly 26. Moreover, the clamping of the escort cup 22 and pilot cup 24 in the first jaw assembly 26 helps prevent dislodgement and also prevent any splayed ends of the cable 10 from interfering with the jaw assembly 26 or the biasing member 36 that would adversely affect the connection made by the splice.

Further insertion causes the cable 10 and the pilot cup 24 to enter the carrier 28. The escort cup 22 is received in the opening in the first region 100 of the carrier 28. The pilot cup 22 and the cable 10 pass through the second jaw assembly 30 causing the second jaw assembly to engage the inner layer of the cable. The cable 10 can either terminate in the carrier 28 or the pilot cup 24 and cable 10 can pass through the back wall 94 and the aperture 106 depending on the cable length. The pilot cup 24 can initially move the second jaw assembly 30 in the carrier, expanding the second jaw assembly 30 until a certain point is reached where the pilot cup 24 will pass through the jaw members 108 and the retainer 110.

In an alternative embodiment, the guide 20, escort cup 22, and the pilot cup 24 can be removed from the casing 12 prior to inserting the cable 10. Because certain cables have a tendency to splay a significant amount, the cables can be inserted at least partially into the guide 20 and then the outer layer can be removed to expose the inner layer. After the cable is properly retained, i.e. after sliding the escort cup 22 over the outer strands and the pilot cup 24 over the inner strands, the guide 20, escort cup 22, and pilot cup 24 can be inserted back into the casing 12 along with the cable 10.

As best shown in FIG. 38, the configuration of the splice may also be used in a dead-end connector 300. The dead-end

connector 300 includes half of an automatic splice 310 having a casing 312. Although not shown, the dead-end splice 310 can include any combination of the internal components of the splice discussed herein. The closed end of the dead-end connector 300 can be considered the central portion. The casing 312 is attached to a dead-end connector 314. In this exemplary embodiment a clevis-type dead-end connector is used, although other types of connectors may be used as would be understood by one of ordinary skill in the art. The dead-end connector 314 includes a retaining washer 316, a yoke 318, and a bail 320. A clevis pin 322 is secured to the bail 320 and retained by a cotter pin 324.

FIGS. 39-45 show an exemplary embodiment of a jaw assembly 400 that can be used as one, or both, of the jaw assemblies described above. FIG. 39 shows the jaw assembly 400 positioned in a casing 402 (half of the splice is shown). An indicator 404 is positioned on the end of the casing 402. The indicator 404 can be color coded to provide information to a user, such as the type of conductor that is spliced. A conductor 406 is inserted into the casing 402 and a pilot cup 408 is connected to the end of the conductor 406. A center stop 410 is positioned in the casing 402. A biasing member 412 is positioned between the center stop 410 and the jaw assembly 400. The biasing member 412 biases the jaw assembly 400 toward the end of the casing 402. As noted above, the jaw assembly 400 can also be configured to operate in the carriers 28, 200 discussed above.

The jaw members 420 are substantially identical as best shown in FIGS. 40 and 41, and the same reference numbers will be used for like parts in describing the jaw members 420. Though three jaw members 420 are shown in this exemplary embodiment, other amounts of jaw members 420 can also be used.

As best shown in FIGS. 42 and 43, the jaw members 420 have a jaw body 422, with a front jaw surface 424 and a rear jaw surface 426. The jaw body 422 has an arcuate outer surface 428 and an arcuate inner surface 430, relative to the casing 402. At least a portion of the jaw body 422 tapers towards the front jaw surface 424. This taper is similar to or corresponds to the taper of the inner casing surface or inner carrier surface, allowing the jaw members 420 to slide within the first chamber or the carrier as required. At least a portion of the jaw body 422 inner surface 430 contains a series of teeth 432. The teeth 432 may have any shape, pitch, length, width, or spacing. In the exemplary embodiment, the teeth 432 extend from the inner surface 430 at an angle towards the rear jaw surface 426.

The jaw members 420 include a projection 434 extending from the jaw body 422 and a groove 436 extending into the jaw body 422. In certain embodiments, the projection 434 and groove 436 can have a circumferential or spiral configuration. The projection 434 and groove 436 may have a variety of sizes or shapes. The projection 434 and groove 436 are aligned, so that a single part may be used for the jaw members 420. When placed together, the projections 434 will mate with the grooves 436. This mating relationship couples the jaw members 420 to prevent one jaw member 420 from moving axially relative to the other jaw member 420, ensuring substantially uniform axial movement between the jaw members 420. The position and configuration of the projections 434 and grooves 436 can result in three jaw members substantially covering the entire circumference of an associated cable, taking into account for gaps or spaces between the jaw members. When used inside of a carrier 28, 200 as described above, the use of the jaw assembly 400 can remove the need for a retainer 110 to couple the jaws together.

FIG. 44 shows a rear portion of the jaw member 420 and an example of the projection 434. The projection 434 includes a base 438 positioned at or near the jaw body 422 and a point 440 positioned separate from the jaw body 422. An outer surface of the projection 434 has a first radius of curvature PR1 and an inner surface of the projection 434 has a second radius of curvature PR2. The first radius of curvature PR1 can be different from the second radius of curvature PR2. The first radius of curvature PR1 can be equal to or substantially the same as the curvature of the outer surface 428 of the jaw body 422.

FIG. 45 best shows an example of the groove 436. The groove 436 includes an inner end 442 positioned at or near the inner surface 430 of the jaw body 422 and an outer end 444 positioned at or near the outer surface 428 of the jaw body 422. The groove 436 can have a varying curvature between the inner end and the outer end. For example, the groove can have a first radius of curvature GR1 near the inner end and a second radius of curvature GR2 near the outer end. In the illustrated example, the first radius of curvature GR1 is greater than the second radius of curvature GR2. The first and second groove curvatures GR1, GR2 are shown for reference, as the illustrated groove 436 contains more than two curvatures. In some embodiments, one curvature, two curvatures, or more than three different curvatures can be used. The curvature of the groove can also vary infinitely from the inner end 442 to the outer end 444. In the illustrated embodiment, the curvature of the groove 436 varies to match the curvature of the outer surface 428 of the jaw body 422.

Any of the features described herein can also be utilized with other types of splices. For example, the features described herein can be utilized with a corrosion resistant splice as described in U.S. Pat. No. 7,799,996, the disclosure of which is herein incorporated by reference in its entirety.

The foregoing detailed description of the certain exemplary embodiments has been provided for the purpose of explaining the principles of the invention and its practical application, thereby enabling others skilled in the art to understand the invention for various embodiments and with various modifications as are suited to the particular use contemplated. This description is not necessarily intended to be exhaustive or to limit the invention to the exemplary embodiments disclosed. Any of the embodiments and/or elements disclosed herein may be combined with one another to form various additional embodiments not specifically disclosed. Accordingly, additional embodiments are possible and are intended to be encompassed within this specification and the scope of the appended claims. The specification describes specific examples to accomplish a more general goal that may be accomplished in another way.

As used in this application, the terms “front,” “rear,” “upper,” “lower,” “upwardly,” “downwardly,” and other orientational descriptors are intended to facilitate the description of the exemplary embodiments of the present invention, and are not intended to limit the structure of the exemplary embodiments of the present invention to any particular position or orientation. Terms of degree, such as “substantially” or “approximately” are understood by those of ordinary skill to refer to reasonable ranges outside of the given value, for example, general tolerances associated with manufacturing, assembly, and use of the described embodiments.

11

What is claimed:

- 1. A cable splice comprising:
 - a casing having a central portion and a first end including a first aperture, wherein the casing defines an interior cavity;
 - a jaw assembly positioned in the interior cavity and moveable between a loading position and a terminated position for engaging a conductor; and
 - a biasing member biasing the jaw assembly toward the terminated position,

wherein the jaw assembly includes a jaw member having a jaw body, a curvilinear projection extending from the jaw body and a curvilinear groove extending into the jaw body, the projection and groove aligned with one another and configured to mate with a respective groove and projection of an adjacent jaw member, and wherein the projection has a spiral configuration and the groove has a spiral configuration.

- 2. The cable splice of claim 1, wherein the jaw assembly includes a second jaw member and a third jaw member.

- 3. The cable splice of claim 1, wherein the groove includes a first radius of curvature and a second radius of curvature, and wherein the first radius of curvature is different than the second radius of curvature.

- 4. The cable splice of claim 3, wherein the groove includes an inner end positioned near an inner surface of the jaw body and an outer end positioned near an outer surface of the jaw body, the first radius of curvature positioned at the inner end and the second radius of curvature positioned at the outer end.

- 5. The cable splice of claim 1, wherein a curvature of the groove varies to match an outer surface of the jaw body.

- 6. The cable splice of claim 1, wherein the projection includes a base and point, and wherein the projection tapers from the base to the point.

- 7. The cable splice of claim 1, wherein the projection includes an outer surface having a first radius of curvature and an inner surface having a second radius of curvature.

- 8. The cable splice of claim 1, wherein the jaw assembly is positioned inside of a carrier.

- 9. The cable splice of claim 8, wherein the carrier includes a first chamber and a second chamber.

- 10. A cable splice comprising:
 - a casing having a central portion and a first end including a first aperture, wherein the casing defines an interior cavity;
 - a first jaw positioned in the interior cavity and moveable between a loading position and a terminated position, the first jaw having a first protrusion and a first groove;
 - a second jaw positioned in the interior cavity and moveable between the loading position and the terminated position, the second jaw having a second protrusion and a second groove; and

12

- a third jaw positioned in the interior cavity and moveable between the loading position and the terminated position, the third jaw having a third protrusion and a third groove,

wherein the first, second, and third jaws are positioned so that the each of the projections is mated with a respective groove and wherein each of the projections includes a base and point, and wherein each of the projections tapers from the base to the point.

- 11. The cable splice of claim 10, wherein each of the projections has a spiral configuration and each of the grooves has a spiral configuration.

- 12. The cable splice of claim 10, wherein the first groove includes a first radius of curvature and a second radius of curvature, and wherein the first radius of curvature is different than the second radius of curvature.

- 13. The cable splice of claim 10, wherein the first jaw has a first jaw body and a curvature of the first groove varies to match an outer surface of the first jaw body.

- 14. The cable splice of claim 10, wherein the first projection includes an outer surface having a first radius of curvature and an inner surface having a second radius of curvature, and wherein the first radius of curvature is different than the second radius of curvature.

- 15. The cable splice of claim 10, wherein the first jaw, second jaw, and third jaw are positioned inside of a carrier.

- 16. The cable splice of claim 15, wherein the carrier includes a first chamber and a second chamber.

- 17. A jaw for a utility line cable splice comprising:
 - a jaw body having a front surface, a rear surface, a curved body outer surface, and a curved body inner surface, the jaw body configured to be positioned inside of a swaged casing;

a projection extending from the jaw body, the projection including a base, a point, a curved projection outer surface, and a curved projection inner surface; and

a groove extending into the jaw body, the groove including an inner end and an outer end, wherein the groove includes a first radius of curvature and a second radius of curvature, and wherein the first radius of curvature is not equal to the second radius of curvature,

wherein the projection has a spiral configuration and tapers from the base to the point.

- 18. The jaw of claim 17, wherein a curvature of the groove varies to match an outer surface of the jaw body.

- 19. The jaw of claim 17, wherein the projection includes a base and point, and wherein the projection tapers from the base to the point.

* * * * *