

[54] **THRUST BEARING ARRANGEMENT FOR A DEADSHAFT MOUNTED GRINDER WHEELHEAD**

3,247,621 4/1966 Aller51/168
 3,301,613 1/1967 De Claire308/122 X

[75] Inventors: Merle E. Ryan, William D. Stremel, both of Dayton, Ohio

[73] Assignee: The Bendix Corporation, Southfield, Mich.

[22] Filed: June 24, 1971

[21] Appl. No.: 156,277

[52] U.S. Cl.51/168, 308/160

[51] Int. Cl.B24b 41/00

[58] Field of Search.....51/168; 308/DIG. 5, 308/160, 122

FOREIGN PATENTS OR APPLICATIONS

955,510 4/1964 Great Britain.....308/122
 639,293 6/1950 Great Britain.....308/122

Primary Examiner—James L. Jones, Jr.

Attorney—John R. Benefiel, Plante, Hartz, Smith & Thompson

[57] **ABSTRACT**

A thrust bearing arrangement is disclosed for a grinder wheelhead of the type that is rotatably mounted on a fixed central shaft, and comprises locating the thrust surfaces on a separate portion of the housing proximate the grinding wheel rather than on the fixed central shaft in order to minimize errors due to thermal expansion of the fixed central shaft.

[56] **References Cited**

UNITED STATES PATENTS

2,735,240 2/1956 Fries et al.....51/106 MH

6 Claims, 2 Drawing Figures

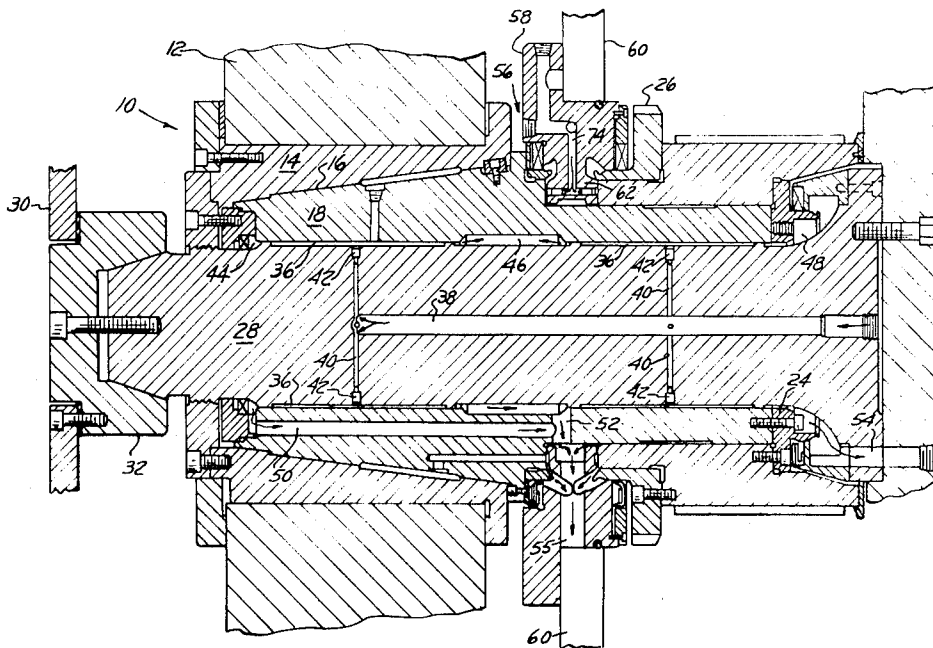

FIG. 1

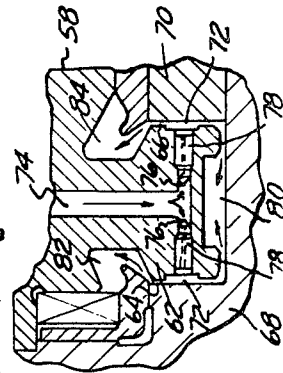
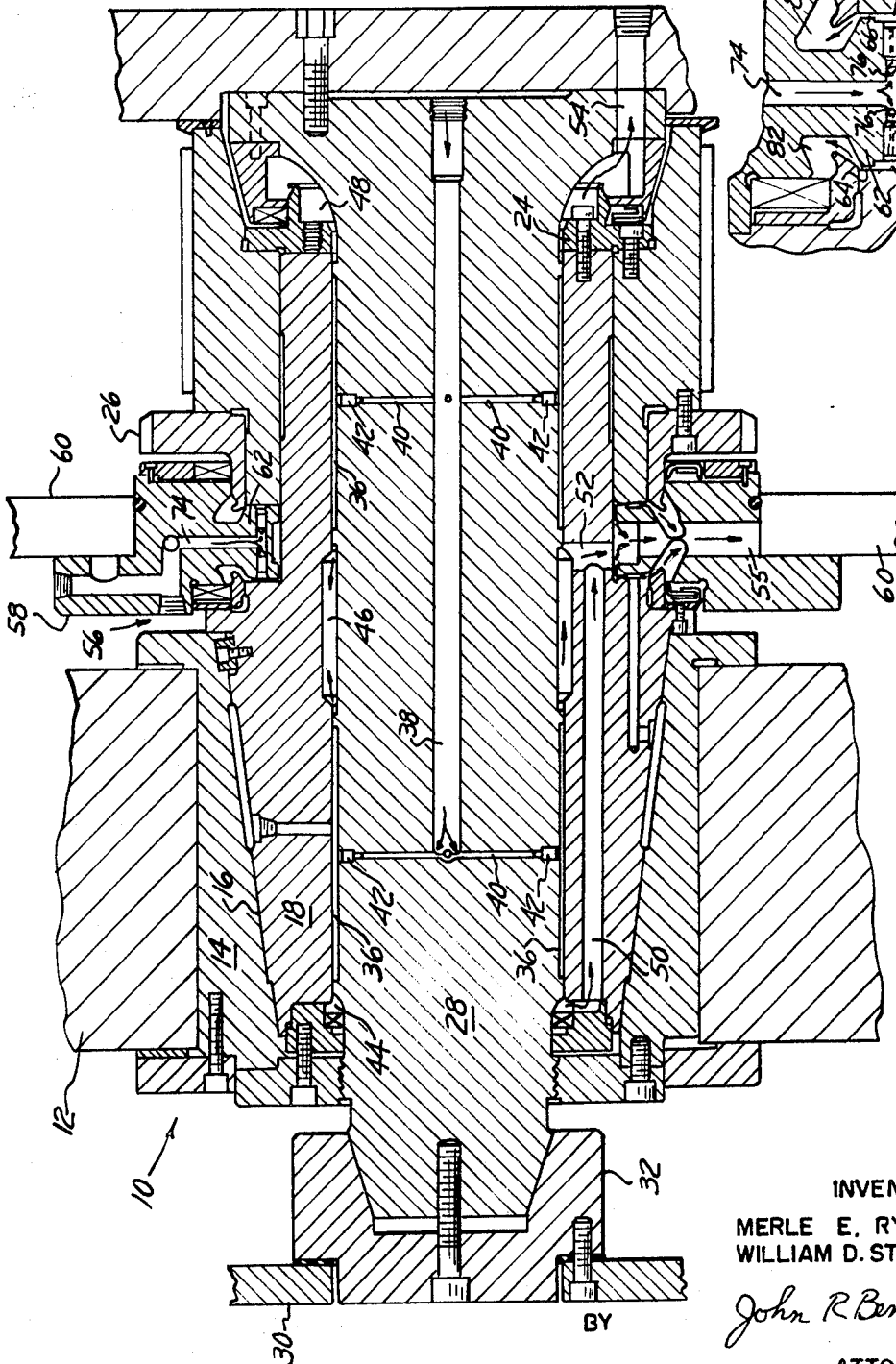

FIG. 2

INVENTORS
MERLE E. RYAN
WILLIAM D. STREMEL

John R. Benefield

ATTORNEY

THRUST BEARING ARRANGEMENT FOR A DEADSHAFT MOUNTED GRINDER WHEELHEAD

BACKGROUND OF THE INVENTION

The use of a "deadshaft" mounting of grinder wheelheads in which a fixed central shaft is used to mount the grinding wheelhead as described in U.S. Pat. No. 3,247,621 assigned to the assignee of the present application has led to many advantages, chiefly the elimination of cantilevering or overhang mounting of the wheelhead hub and the resultant excessive deflection thereof without rendering removal of the grinding wheel excessively time consuming. In addition, the "deadshaft" design allows placement of the radial bearings directly under the load for the most efficient loading thereof.

In this arrangement, the thrusting surfaces were located proximate the wheel as per the conventional practice which dictates minimizing thermal growth by placing the thrusting surfaces as close as possible to the wheel.

However, in the deadshaft design, such close placement did not eliminate excessive thermal growth and accompanying errors and/or excessive duration of warm-up periods. It has been found that the length of the fixed central shaft as well as its proximity to the radial bearings and the heat produced therein will cause relatively great movement of the thrusting surfaces relative to the remainder of the housing, the base mounted crush rolls and workpiece mounting spindle, with which the grinding wheel must be located with great precision for high accuracy form grinding processes.

Therefore, it is an object of the present invention to provide a thrust bearing arrangement for a deadshaft mounted grinding wheelhead which does not produce excessive errors and/or require unduly long warm-up periods.

SUMMARY OF THE INVENTION

These and other objects which will become apparent upon a reading of the following specification and claims is accomplished by locating the thrusting surfaces on a relatively short housing structure remotely from the fixed central shaft and the radial bearings mounted therein and adjacent the grinding wheel.

BRIEF DESCRIPTION OF THE DRAWINGS

FIG. 1 is a view of a grinding wheel and mounting arrangement in longitudinal section.

FIG. 2 is a detailed view of a portion of the thrust bearings shown in FIG. 1.

DETAILED DESCRIPTION

In the following detailed description certain specific terminology will be utilized for the sake of clarity and specific embodiments will be described in order to provide a complete understanding of the invention, but it is to be understood that the invention is not so limited and may be practiced in a variety of forms and embodiments.

Referring to the drawings, and particularly FIG. 1, the wheelhead assembly 10 is depicted including a grinding wheel 12 mounted on a hub 14 in turn pressed onto tapered surface 16 of a hollow driving shaft 18 by means of a collar 20 so as to provide a firm driving connection therebetween.

Hollow drive shaft 18 has a drive pulley 22 fixed to its other end by means of a retainer 24 so as to provide a driving engagement with a belt drive (not shown) to rotate the grinding wheel 12 during grinding operations.

A bull gear 26 is also fixed to the hollow shaft 18 to provide a driving surface for a slow speed drive (not shown) to rotate the grinding wheel 12 during crush dressing operations.

The hollow shaft 18 is supported radially by means of a fixed central shaft 28, supported at one end on door structure 30 and tapered cap 32, bolted to both elements, and at the other end by housing structure 34 bolted thereto.

The hollow shaft 18 is supported on the fixed central shaft 28 by means of a hydrostatic bearing arrangement including a pair of series of circumferentially spaced pockets 36 formed in the fixed central shaft 28 and supplied with a fluid from a source (not shown) via central passage 38, radial passage 40, and orifices 42. Fluid passing out of the pockets 36 past the clearances between the fixed central shaft 28 and the hollow drive shaft 18 is collected in annular spaces 44, 46, and 48 and passes into return passages 50, 52, and 54 to be returned to the sump (not shown) via passage 55. The fluid contained in these pockets provides a low friction support for rotating of the wheelhead assembly 10 thereon as is well known in the art.

The hollow drive shaft 18 is positioned against axial loads by means of a separate thrust bearing arrangement 56 according to the present invention.

This arrangement includes a thrust ring member 58 fixed to housing structure 60 so as to be securely supported against lateral loads.

The thrust ring 58 includes an annular portion 62 (FIG. 2) disposed extending around the exterior of hollow drive shaft 18 between a pair of thrust surfaces 64, 66 of the wheelhead assembly 10 formed by shoulders 68, 70 on the hollow drive shaft 18 and hub 22, respectively.

A series of circumferentially spaced pockets 72 are formed in the annular portion 62 facing the thrust surfaces 64, 66 and are supplied with fluid via radial passage 74 and a series of axial passages 76 containing metering orifices 78. Flow past clearances between the annular portion 62 and other thrust surfaces 64, 66 is collected in annular spaces 80, 82 and 84 in turn collected in passage 55 for return to the sump (not shown).

As the thrust surfaces are disposed proximate the wheel 12, a minimal length of the drive shaft 18 is subject to thermal expansion which results in axial displacement of the grinding wheel 12 relative to the thrust bearing 56.

Furthermore, the fixed thrust absorbing structure itself, i.e., the thrust ring 58, is of relatively narrow dimension so that thermal expansion thereof also is minimal.

Finally, the thrust bearing arrangement 56 is remotely located with respect to the radial bearings so that the effect of heat buildup therein on the thrust bearing arrangement is minimized.

Accordingly, the advantages of a "deadshaft" design are realized by the use of the present invention without entailing the penalty of thermal growth errors and/or excessive warm-up periods.

Many variations are of course possible within the scope of the invention. For example, while the use of

hydrostatic bearings is highly advantageous in this context it would of course be possible to utilize mechanical bearings as described in the aforesaid U.S. patent.

What is claimed is:

- 1. A grinding wheel mounting arrangement comprising:
 - a grinding wheel;
 - a hollow drive shaft connected to said grinding wheel;
 - a fixed central shaft disposed within said drive shaft; bearing means rotationally supporting said drive shaft on said fixed central shaft;
 - thrust bearing means including a fixed thrust member disposed around the exterior of said drive shaft proximate to said grinding wheel and cooperating with thrust surfaces on said drive shaft to restrain axial movement thereof.
- 2. The arrangement of claim 1 wherein said thrust member includes an annular portion extending radially between a pair of shoulders fixed to said drive shaft.

3. The arrangement of claim 1 wherein said fixed central shaft is fixed at both ends.

4. A mounting arrangement for a member to be rotated comprising:

- a hollow drive shaft connected to said member;
- a fixed central shaft disposed within said drive shaft; bearing means rotationally supporting said drive shaft on said fixed central shaft;
- thrust bearing means including a fixed thrust member disposed around the exterior of said drive shaft adjacent said member and cooperating with thrust surfaces on said drive shaft to restrain axial movement thereof.

5. The arrangement of claim 4 wherein said thrust member includes an annular portion extending radially between a pair of shoulders fixed to said drive shaft.

6. The arrangement of claim 4 wherein said member is a grinding wheel.

* * * * *

25

30

35

40

45

50

55

60

65