



- (51) International Patent Classification:  
A61B 17/04 (2006.01)
- (21) International Application Number:  
PCT/US2013/039711
- (22) International Filing Date:  
6 May 2013 (06.05.2013)
- (25) Filing Language: English
- (26) Publication Language: English
- (30) Priority Data:  
61/642,681 4 May 2012 (04.05.2012) US
- (71) Applicant: **SI-BONE INC.** [US/US]; 3055 Olin Avenue, Suite 2200, San Jose, CA 95128 (US).
- (72) Inventors: **MAULDIN, Richard, Garret**; 3055 Olin Avenue, Suite 2200, San Jose, CA 95128 (US). **YERBY, Scott, A.**; 3055 Olin Avenue, Suite 2200, San Jose, CA 95128 (US). **REILEY, Mark**; 3055 Olin Avenue, Suite 2200, San Jose, CA 95128 (US). **SCHNEIDER, Bret**; 3055 Olin Avenue, Suite 2200, San Jose, CA 95128 (US).
- (74) Agents: **CHU, Winston, S.** et al.; Shay Glenn LLP, 2755 Campus Drive, Suite 210, San Mateo, CA 94403 (US).
- (81) Designated States (unless otherwise indicated, for every kind of national protection available): AE, AG, AL, AM,

AO, AT, AU, AZ, BA, BB, BG, BH, BN, BR, BW, BY, BZ, CA, CH, CL, CN, CO, CR, CU, CZ, DE, DK, DM, DO, DZ, EC, EE, EG, ES, FI, GB, GD, GE, GH, GM, GT, HN, HR, HU, ID, IL, IN, IS, JP, KE, KG, KM, KN, KP, KR, KZ, LA, LC, LK, LR, LS, LT, LU, LY, MA, MD, ME, MG, MK, MN, MW, MX, MY, MZ, NA, NG, NI, NO, NZ, OM, PA, PE, PG, PH, PL, PT, QA, RO, RS, RU, RW, SC, SD, SE, SG, SK, SL, SM, ST, SV, SY, TH, TJ, TM, TN, TR, TT, TZ, UA, UG, US, UZ, VC, VN, ZA, ZM, ZW.

- (84) Designated States (unless otherwise indicated, for every kind of regional protection available): ARIPO (BW, GH, GM, KE, LR, LS, MW, MZ, NA, RW, SD, SL, SZ, TZ, UG, ZM, ZW), Eurasian (AM, AZ, BY, KG, KZ, RU, TJ, TM), European (AL, AT, BE, BG, CH, CY, CZ, DE, DK, EE, ES, FI, FR, GB, GR, HR, HU, IE, IS, IT, LT, LU, LV, MC, MK, MT, NL, NO, PL, PT, RO, RS, SE, SI, SK, SM, TR), OAPI (BF, BJ, CF, CG, CI, CM, GA, GN, GQ, GW, ML, MR, NE, SN, TD, TG).

**Published:**

- with international search report (Art. 21(3))
- before the expiration of the time limit for amending the claims and to be republished in the event of receipt of amendments (Rule 48.2(h))

(54) Title: FENESTRATED IMPLANT

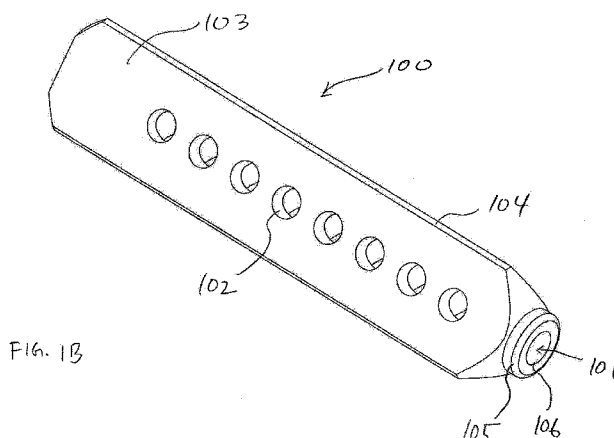

(57) Abstract: The present invention relates generally to implants used in medical procedures such as bone fixation or fusion. More specifically, this application relates to fenestrated implants used bone fixation or fusion.



**FENESTRATED IMPLANT****CROSS REFERENCE TO RELATED APPLICATIONS**

5 [0001] This application claims priority to U.S. Provisional Application No. 61/642,681, titled "FENESTRATED IMPLANT" and filed May 4, 2012, which is herein incorporated by reference in its entirety for all purposes.

**INCORPORATION BY REFERENCE**

10 [0002] All publications and patent applications mentioned in this specification are herein incorporated by reference to the same extent as if each individual publication or patent application was specifically and individually indicated to be incorporated by reference. For example, this application incorporates by reference in their entireties U.S. Patent Publication No. 2011/0087294 and U.S. Patent Publication No. 2011/0118785.

15 **FIELD**

[0003] This application relates generally to implants used in medical procedures such as bone fixation or fusion. More specifically, this application relates to fenestrated implants used in bone fixation or fusion.

20 **BACKGROUND**

[0004] Many types of hardware are available both for the fixation of bones that are fractured and for the fixation of bones that are to be fused (arthrodesed).

25 [0005] For example, the human hip girdle is made up of three large bones joined by three relatively immobile joints. One of the bones is called the sacrum and it lies at the bottom of the lumbar spine, where it connects with the L5 vertebra. The other two bones are commonly called "hip bones" and are technically referred to as the right ilium and the left ilium. The sacrum connects with both hip bones at the sacroiliac joint (in shorthand, the SI-Joint).

30 [0006] The SI-Joint functions in the transmission of forces from the spine to the lower extremities, and vice-versa. The SI-Joint has been described as a pain generator for up to 22% of lower back pain.

[0007] To relieve pain generated from the SI Joint, sacroiliac joint fusion is typically indicated as surgical treatment, e.g., for degenerative sacroiliitis, inflammatory sacroiliitis, iatrogenic instability of the sacroiliac joint, osteitis condensans ilii, or traumatic fracture dislocation of the pelvis. Currently, screws and screws with plates are used for sacro-iliac fusion.

[0008] In order to promote bone growth into the implant and enhance fusion of the implant with the bone, pockets or channels can be created in the implant that promote bone growth into the implant. However, these pockets or channels may weaken the structural integrity of the implant, which can also be required to bear large stresses. Therefore, it would be desirable to provide an implant with pockets or channels to promote bone growth while substantially maintaining the structural integrity of the implant.

### SUMMARY OF THE DISCLOSURE

[0009] The present invention relates generally to implants used in medical procedures such as bone fixation or fusion. More specifically, this application relates to fenestrated implants used in bone fixation or fusion.

[00010] In some embodiments, an implant for bone fixation is provided. The implant can include an elongate body having a longitudinal axis and a rectilinear cross section transverse to the longitudinal axis, a plurality of faces, a plurality of apices joining the plurality of faces, a central lumen extending along the longitudinal axis of the elongate body, and a plurality of holes with openings on the plurality of faces, wherein the holes are in fluid communication with the central lumen.

[00011] In some embodiments, the holes are circular. In some embodiments, the holes are oval. In some embodiments, the holes are arranged in a single longitudinal row on each face. In some embodiments, the holes are arranged in a plurality of longitudinal rows on each face.

[00012] In some embodiments, the elongate body is coated with a biologic aid.

[00013] In some embodiments, the holes have a diameter that is about equal to the diameter of the central lumen. In some embodiments, the holes have a diameter than is between about 0.2 to 0.5 of the width of the faces.

[00014] In some embodiments, an implant for bone fixation is provided. The implant can include an elongate body having a longitudinal axis and a rectilinear cross section transverse to the longitudinal axis, a plurality of faces, a plurality of apices joining the plurality of faces, a central lumen extending along the longitudinal axis of the elongate body, and a plurality of side pockets extending along a portion of each of the plurality of faces, wherein the side pockets have a depth that does not extend to the central lumen.

[00015] In some embodiments, each of the plurality of faces has only one side pocket. In some embodiments, each of the side pockets is centered on each of the faces. In some embodiments, the side pockets have a width that is between about 0.2 to 0.8 of the width of the faces and a length that is between about 0.5 to 0.9 of the length of the faces.

[00016] In some embodiments, the implant further includes a plurality of holes located within the side pockets, wherein the holes are in fluid communication with the central lumen.

[00017] In some embodiments, an implant for bone fixation is provided. The implant can include an elongate body having a longitudinal axis and a rectilinear cross section transverse to the longitudinal axis, a plurality of faces, a plurality of apices joining the plurality of faces, and a central lumen extending along the longitudinal axis of the elongate body, wherein each one of the plurality of apices includes a groove that extends along the length of the apex.

[00018] In some embodiments, an implant for bone fixation is provided. The implant can include an elongate body having a longitudinal axis and a rectilinear cross section transverse to the longitudinal axis, a plurality of faces, a plurality of apices joining the plurality of faces, and a central lumen extending along the longitudinal axis of the elongate body, wherein each one of the plurality of apices includes a plurality of pockets located at discrete points along the length of each apex.

[00019] In some embodiments, an implant for bone fixation is provided. The implant can include an elongate body having a longitudinal axis, a distal end, a proximal end, and a rectilinear cross section transverse to the longitudinal axis, a plurality of faces, each face formed from a wall with a thickness between about 2 to 3 mm in thickness, and a plurality of fenestrations disposed on each face.

[00020] In some embodiments, the distal end of the elongate body is formed into one or more cutting edges.

[00021] In some embodiments, the rectilinear cross section has three sides. In some embodiments, the rectilinear cross section has four sides.

[00022] In some embodiments, the fenestrations are located on a distal portion of the elongate body that is configured to be implanted within the sacrum of a patient while the proximal portion of the elongate body that is configured to be implanted within the ilium is free from fenestrations.

[00023] In some embodiments, the fenestrations are arranged in a staggered pattern.

[00024] In some embodiments, the implant further includes a cap on the proximal end of the elongate body, the cap having a hole sized to receive a guide pin.

[00025] In some embodiments, the elongate body has an inner surface and an outer surface that are porous. In some embodiments, the elongate body has an inner surface and an outer surface that are roughened. In some embodiments, the elongate body has an inner surface and an outer surface that are plasma coated. In some embodiments, the elongate body has an inner surface and an outer surface that are coated with a biologic aid. In some embodiments, the biologic aid is a bone morphogenetic protein.

## BRIEF DESCRIPTION OF THE DRAWINGS

[00026] The novel features of the invention are set forth with particularity in the claims that follow. A better understanding of the features and advantages of the present invention will be  
5 obtained by reference to the following detailed description that sets forth illustrative embodiments, in which the principles of the invention are utilized, and the accompanying drawings of which:

[00027] FIGS. 1A-1V illustrate various embodiments of implant structures with different fenestrations.

10 [00028] FIGS. 2A-2D are side section views of the formation of a broached bore in bone according to one embodiment of the invention.

[00029] FIGS. 2E and 2F illustrate the assembly of a soft tissue protector system for placement over a guide wire.

15 [00030] FIGS. 3 and 4 are, respectively, anterior and posterior anatomic views of the human hip girdle comprising the sacrum and the hip bones (the right ilium, and the left ilium), the sacrum being connected with both hip bones at the sacroiliac joint (in shorthand, the SI-Joint).

[00031] FIGS. 5 to 7A and 7B are anatomic views showing, respectively, a pre-implanted perspective, implanted perspective, implanted anterior view, and implanted cranio-caudal section view, the implantation of three implant structures for the fixation of the SI-Joint using a lateral  
20 approach through the ilium, the SI-Joint, and into the sacrum.

[00032] FIGS. 8A and 8B illustrate another embodiment of an implant structure with fenestrations.

[00033] FIGS. 9A and 9B illustrate yet another embodiment of an implant structure with fenestrations.

25

## DETAILED DESCRIPTION

[00034] Elongated, stem-like implant structures 20 like that shown in FIG. 1A make possible the fixation of the SI-Joint (shown in anterior and posterior views, respectively, in FIGS. 3 and  
30 4) in a minimally invasive manner. These implant structures 20 can be effectively implanted through the use of a lateral surgical approach. The procedure is desirably aided by conventional lateral and/or anterior-posterior (A-P) visualization techniques, e.g., using X-ray image intensifiers such as a C-arms or fluoroscopes to produce a live image feed that is displayed on a TV screen.

[00035] In some embodiments, the implant structures 20 can include pockets, pathways, cavities, openings, fenestrations, channels and/or recesses that allow bone graft materials to be incorporated into the implant structure. These bone graft materials can promote bone growth into and/or around the implant structure, which can reduce the time it takes for the implant structure to be stably integrated with the bone. Bone graft materials can be applied to and/or injected into the implant structure before implantation or applied after implantation by injection of the bone graft material into a proximal cannula or other conduit. In some embodiments, the surfaces of the implant structure 20 can be roughened or textured to promote bone growth and adherence of the bone graft materials. The internal and/or external surfaces can be roughened or textured by mechanical means or can be spray coated with a roughening material.

[00036] The bone graft materials can be a liquid, gel, slurry, paste, powder or other form, and can include a biologic aid that can promote and/or enhance bony ingrowth, tissue repair, and/or reduce inflammation, infection and pain. For example, the biologic aid can include growth factors, such as bone morphogenetic proteins (BMPs), hydroxyapatite in, for example, a liquid or slurry carrier, demineralized bone, morselized autograft or allograft bone, medications to reduce inflammation, infection or pain such as analgesics, antibiotics and steroids. In some embodiments, the growth factors can be human recombinant growth factors, such as hr-BMP-2 and/or hr-BMP-7, or any other human recombinant form of BMP, for example. The carrier for the biologic aid can be a liquid or gel such as saline or a collagen gel, for example. The biologic aid can also be encapsulated or incorporated in a controlled released formulation so that the biologic aid is released to the patient at the implant site over a longer duration. For example, the controlled release formulation can be configured to release the biologic aid over the course of days or weeks or months, and can be configured to release the biologic aid over the estimated time it would take for the implant site to heal. The amount of biologic aid delivered to the implant structure can be controlled using a variety of techniques, such as controlling or varying the amount of coating material applied to the implant and/or controlling or varying the amount of biologic aid incorporated into the coating material. In some embodiments, it may be important to control the amount of biologic aid delivered because excessive use of certain biologic aids can result in negative effects such as radicular pain, for example.

[00037] In general, any pockets, pathways, cavities, openings, fenestrations, channels and/or recesses in the implant structure may weaken its structural strength, including for example the bending and shear strengths. The following examples of implant structures are variations of the solid triangular implant structure 20 of FIG. 1A, which has a single central, longitudinally oriented lumen or cannula for receiving a guide wire or guide pin. The relative bending and shear strengths can be compared to the cannulated but otherwise solid implant structure 20 of

FIG. 1A, which can be assigned a bending strength of 1.00 and a shear strength of 1.00. The relative bending and shear strengths can be modified or optimized for structural strength and ability to promote bone grafting by varying the size, number, spacing, location, orientation, and shape of the pockets, pathways, cavities, openings, fenestrations, channels and/or recesses.

5 Although the embodiments illustrated herein show triangular implant structures, implant structures with different rectilinear shapes, such as rectangular or square, can be used or substituted for the triangular implant structures.

[00038] FIGS. 1B-D illustrate an embodiment of a triangular implant structure 100 having a central lumen 101 and a series of holes 102 on each face 103 of the implant structure 100 that  
10 reach and provide access to the central lumen 101. The holes 102 can be centered on the face 103 and extend inwardly at an angle that is substantially perpendicular or normal to the face 103 of the implant structure 100. In some embodiments, each apex 104 can be beveled or rounded. In some embodiments, the distal end 105 of the implant structure 100 can be tapered to facilitate implantation into the bone. In some embodiments, the diameter of the holes 102 can be equal to  
15 or substantially equal to the diameter of the central lumen 101. In other embodiments, the diameter of the holes 102 can be greater than or less than the diameter of the central lumen 101. In some embodiments, the implant structure 100 illustrated in FIGS. 1B-D has a relative bending strength of about 0.82 and a relative shear strength of about 0.66. In some embodiments, to inject or load the implant structure 100 with bone graft materials, the distal hole 106 of the  
20 central lumen 101 can be blocked or sealed so that flow of the bone graft materials fills the central lumen 101 and exits the side holes 102.

[00039] In some embodiments, the holes 102 can have a diameter ( $D_1$ ) that is about 0.3 of width ( $W_1$ ) of the face 103 of the implant structure 100. In some embodiments, the holes 102 can have a diameter that is greater than about 0.3 of the width of the face 103 of the implant  
25 structure 100. In some embodiments, the holes 102 can have a diameter that is less than about 0.3 of the width of the face 103 of the implant structure 100. In some embodiments, the holes 102 can have a diameter that is between about 0.2 to about 0.5 of the width of the face 103 of the implant structure. In some embodiments, the holes 102 can be separated from adjacent holes 102 by about 2/3 of the hole diameter, where separation distance ( $S_1$ ) is measured by the distance  
30 between the circumference of the holes 102. In some embodiments, the holes 102 can be separated from adjacent holes 102 by less than about 2/3 of the hole diameter. In some embodiments, the holes 102 can be separated from adjacent holes 102 by greater than about 2/3 of the hole diameter. In some embodiments, the holes 102 can be separated from adjacent holes 102 by about 0.5 to about 2 times, or about 0.5 to about 1 times the hole 102 diameter. In some  
35 embodiments, the relative bending strength can be at least about 0.5, 0.6, 0.7, 0.8 or 0.9. In some

embodiments, the relative bending strength can be between about 0.5 to 0.9. In some embodiments, the relative shear strength can be at least about 0.5, 0.6, 0.7, 0.8 or 0.9. In some embodiments, the relative shear strength can be between about 0.5 to 0.9.

[00040] FIGS. 1E-G illustrate another embodiment of an implant structure 110 having a central lumen 111 and a series of slots 112 on each face 113 of the implant structure 110 that reach and provide access to the central lumen 111. The slots 112 can be centered on the face 113 and extend inwardly at an angle that is substantially perpendicular or normal to the face 113 of the implant structure 110. In some embodiments, each apex 114 can be beveled or rounded. In some embodiments, the distal end 115 of the implant structure 110 can be tapered to facilitate implantation into the bone. In some embodiments, the width of the slots can be equal to or substantially equal to the diameter of the central lumen 111. In other embodiments, the width of the slots can be greater than or less than the diameter of the central lumen 111. In some embodiments, the implant structure 110 illustrated in FIGS. 1E-G has a relative bending strength of about 0.82 and a relative shear strength of about 0.66. In some embodiments, to inject or load the implant structure 110 with bone graft materials, the distal hole 116 of the central lumen 111 can be blocked or sealed so that flow of the bone graft materials fills and exits the slots 112.

[00041] In some embodiments, the slots 112 can have a width (W3) that is about 0.3 of width (W2) of the face 113 of the implant structure 110. In some embodiments, the slots 112 can have a width that is greater than about 0.3 of the width of the face 113 of the implant structure 110. In some embodiments, the slots 112 can have a width that is less than about 0.3 of the width of the face 113 of the implant structure 110. In some embodiments, the slots 112 can have a width that is between about 0.2 to about 0.6 of the width of the face 113 of the implant structure 110. In some embodiments, the slots 112 can have a length (L3) that is about 0.15 the length (L2) of the face 113. In some embodiments, the slots 112 can have a length that is less than about 0.15 the length of the face 113. In some embodiments, the slots 112 can have a length that is greater than about 0.15 the length of the face 113. In some embodiments, the slots 112 can have a length that is between about 0.1 to 0.4, or about 0.1 to 0.25 the length of the face 113. In some embodiments, the slots 112 are separated (S2) from adjacent slots 112 by about 2/3 the width of the slot 112. In some embodiments, the slots 112 are separated from adjacent slots 112 by greater than about 2/3 the width of the slot 112. In some embodiments, the slots 112 are separated from adjacent slots 112 by less than about 2/3 the width of the slot 112. In some embodiments, the slots 112 can be separated from adjacent slots 112 by about 0.5 to about 2 times, or about 0.5 to about 1 times the slot 112 width. In some embodiments, the relative bending strength can be at least about 0.5, 0.6, 0.7, 0.8 or 0.9. In some embodiments, the relative bending strength can be between about 0.5 to 0.9. In some embodiments, the relative shear



strength can be at least about 0.5, 0.6, 0.7, 0.8 or 0.9. In some embodiments, the relative shear strength can be between about 0.5 to 0.9.

5 [00042] FIGS. 1H-J illustrate another embodiment of an implant structure 120 having a central lumen 121 and a side pocket 122 on each face 123 of the implant structure 120. The side pocket 122 can be a depression, cavity, groove or slot centered on the face 123 having a width, length and depth. In some embodiments, the side pocket 122 is relatively shallow so that it does not extend to the central lumen 121. In some embodiments, each apex 124 can be beveled or rounded. In some embodiments, the distal end 125 of the implant structure 120 can be tapered to facilitate implantation into the bone. In some embodiments, the implant structure 120 illustrated  
10 in FIGS. 1H-J has a relative bending strength of about 0.77 and a relative shear strength of about 0.72. In some embodiments, to load the implant structure 120 with bone graft materials, the bone graft material is applied to the side pockets 122 before implantation. In other embodiments, the bone graft material is applied during implantation, as further described in U.S. Patent Application 61/609,043 titled Tissue Dilator and Protector, which is hereby incorporated  
15 by reference in its entirety and can be applied to the other implants.

[00043] In some embodiments, the side pocket 122 can have a width (W4) that is about 0.5 of width (W5) of the face 123 of the implant structure 120. In some embodiments, the side pocket 122 can have a width that is greater than about 0.5 of the width of the face 123 of the implant structure 120. In some embodiments, the side pocket 122 can have a width that is less than about  
20 0.5 of the width of the face 123 of the implant structure 120. In some embodiments, the side pocket 122 can have a width that is between about 0.2 to about 0.8 of the width of the face 123 of the implant structure 120. In some embodiments, the side pocket 122 can have a length (L4) that is about 0.75 the length (L5) of the face 123. In some embodiments, the side pocket 122 can have a length that is less than about 0.75 the length of the face 123. In some embodiments, the side pocket 122 can have a length that is greater than about 0.75 the length of the face 123. In  
25 some embodiments, the side pocket 122 can have a length that is between about 0.5 to 0.9 of the length of the face 123. In some embodiments, the side pocket 122 can have a depth between about 0.2 mm and 5 mm, or between about 0.2 mm and 2 mm, or between about 0.2 and 1 mm. In some embodiments, the side pocket 122 can have a depth between about 0.25 mm, 0.5 mm,  
30 0.75 mm, 1 mm or 2 mm. In some embodiments, the relative bending strength can be at least about 0.5, 0.6, 0.7, 0.8 or 0.9. In some embodiments, the relative bending strength can be between about 0.5 to 0.9. In some embodiments, the relative shear strength can be at least about 0.5, 0.6, 0.7, 0.8 or 0.9. In some embodiments, the relative shear strength can be between about 0.5 to 0.9.

[00044] FIGS. 1K-M illustrate another embodiment of an implant structure 130 having a central lumen 131, a side pocket 132 on each face 133 of the implant structure 130, and a plurality of holes 134 located within the side pocket 132. The side pocket 132 in the embodiment illustrated in FIGS. 1K-M can be the same as or be similar to the side pocket 122 previously described above and illustrated in FIGS. 1H-J. Likewise, the holes 134 illustrated in FIGS. 1K-M can be the same as or be similar to the holes 102 previously described above and illustrated in FIGS. 1B-D. In some embodiments, as illustrated in FIGS. 1K-M, the holes 134 have a diameter that is less than the diameter of the central lumen 131. In other embodiments, the holes 134 have a diameter than is equal to or greater than the diameter of the central lumen 131. In some embodiments, each apex 135 can be beveled or rounded. In some embodiments, the distal end 136 of the implant structure 130 can be tapered to facilitate implantation into the bone. In some embodiments, the implant structure 130 illustrated in FIGS. 1K-M has a relative bending strength of about 0.74 and a relative shear strength of about 0.62. In some embodiments, to load the implant structure 130 with bone graft materials, the bone graft material is injected and/or applied to the side pockets 132 and holes 134 before implantation. In other embodiments, the bone graft materials can be injected into the central lumen 131, which can have a distal opening 137 that is blocked off or plugged so that the bone graft materials fill the central lumen 131 and exit out the holes 134 which are in fluid communication with the central lumen 131. As the bone graft materials exit the holes 134, the bone graft material can coat and fill both the holes 134 and the side pocket 132. This injection process can be done before implantation, during implantation, or after implantation.

[00045] In some embodiments, the side pocket 132 shown in FIGS. 1K-M has the same or similar dimensions as the side pocket 122 shown in FIGS. 1H-J and described above. In some embodiments, the holes 134 can have a diameter ( $D_2$ ) that is about 0.4 of the width ( $W_6$ ) of the side pocket 132. In some embodiments, the holes 134 can have a diameter that is greater than or less than about 0.4 times the width of the side pocket 132. In some embodiments, the holes 134 can be separated ( $S_3$ ) by about 1.5 times the diameter of the holes 134. In some embodiments, the holes 134 can be separated by greater than or less than about 1.5 times the diameter of the holes 134. In some embodiments, the relative bending strength can be at least about 0.5, 0.6, 0.7, 0.8 or 0.9. In some embodiments, the relative bending strength can be between about 0.5 to 0.9. In some embodiments, the relative shear strength can be at least about 0.5, 0.6, 0.7, 0.8 or 0.9. In some embodiments, the relative shear strength can be between about 0.5 to 0.9.

[00046] FIGS. 1N-P illustrate another embodiment of an implant structure 140 having a central lumen 141 and a plurality of peripheral lumens 142 surrounding the central lumen 141. The peripheral lumens 142 can be oriented longitudinally and can be located between the central

lumen 141 and each apex 143. As illustrated, the implant structure 140 is triangular and has three apices 143 and three peripheral lumens 142 that surround the central lumen 141. In some embodiments, both the central lumen 141 and the peripheral lumens 142 can extend throughout the longitudinal length of the implant structure 140. In other embodiments, the peripheral lumens 142 do not extend throughout the length of the implant structure 140, and instead, the peripheral lumens 142 terminate prior to the distal end 144 of the implant structure 140. In addition, a plurality of side holes 145 can be included in the implant structure 140. Each peripheral lumen 142 can be intersected by a plurality of side holes 145, where each side hole 145 extends between two faces 146 of the implant structure with a side hole opening 147 on each of the two faces 146. The side holes 145 can extend transversely through the implant structure 140 at an angle of about 60 degrees from the surfaces of the faces 146. In some embodiments, each apex 143 can be beveled or rounded. In some embodiments, the distal end 144 of the implant structure 140 can be tapered to facilitate implantation into the bone. In some embodiments, the implant structure 140 illustrated in FIGS. 1N-P has a relative bending strength of about 0.63 and a relative shear strength of about 0.66. In some embodiments, to load the implant structure 140 with bone graft materials, the bone graft material is injected into the peripheral lumens 142, where the bone graft material fills up the peripheral lumens and exits the side holes 145. Injection of the bone graft material can take place before, during, or after implantation. In some embodiments where the peripheral lumens 142 extend completely through the implant structure 140, the distal ends of the peripheral lumens 142 can be blocked or plugged before injection of the bone graft material.

[00047] In some embodiments, the peripheral lumens 142 have a diameter (D3) of about 0.2 times the width (W7) of the faces 146 of the implant structure. In some embodiments, the peripheral lumens 142 have a diameter greater than or less than about 0.2 times the width of the faces 146 of the implant structure. In some embodiments, the peripheral lumens 142 can have a smaller diameter than the central lumen 141. In other embodiments, the peripheral lumens 142 can have an equal or larger diameter than the central lumen 141. In some embodiments, the side holes 145 have a diameter (D4) equal or substantially equal to the diameter of the peripheral lumens 142. In other embodiments, the side holes 145 have a diameter less than or greater than the diameters of the peripheral lumens 142. In some embodiments, the relative bending strength can be at least about 0.5, 0.6, 0.7, 0.8 or 0.9. In some embodiments, the relative bending strength can be between about 0.5 to 0.9. In some embodiments, the relative shear strength can be at least about 0.5, 0.6, 0.7, 0.8 or 0.9. In some embodiments, the relative shear strength can be between about 0.5 to 0.9.

[00048] FIGS. 1Q-S illustrate another embodiment of an implant structure 150 having a central lumen 151. Each apex 152 can be beveled or rounded and can have a plurality of pockets or cavities 153 located at discrete points along the length of the apex 152. These pockets 153 extend from the apex 152 and towards the central lumen 151, but do not reach the central lumen 151. In some embodiments, the pockets 153 have a curved cutout shape, which can correspond in shape to a portion of a cylinder. In some embodiments, the distal end 154 of the implant structure 140 can be tapered to facilitate implantation into the bone. In some embodiments, the implant structure 150 illustrated in FIGS. 1Q-S has a relative bending strength of about 0.89 and a relative shear strength of about 0.86. In some embodiments, to load the implant structure 150 with bone graft materials, the bone graft material is applied externally to the implant structure 150 either before or during implantation. In addition to receiving the bone graft materials, the pockets 153 also function to eliminate or reduce a corner haloing effect.

[00049] In some embodiments, the pockets 153 can have a length (L6) or diameter of about 0.06 of the length (L7) of the apex 152. In some embodiments, the pockets 153 can have a length or diameter greater than or less than about 0.06 of the length of the apex 152. In some embodiments, the pockets 153 can be separated (S4) from adjacent pockets 153 by about 2/3 of the pocket length or diameter. In some embodiments, the pockets 153 can be separated from adjacent pockets 153 by greater than or less than about 2/3 of the hole diameter. In some embodiments, the relative bending strength can be at least about 0.5, 0.6, 0.7, 0.8 or 0.9. In some embodiments, the relative bending strength can be between about 0.5 to 0.95. In some embodiments, the relative shear strength can be at least about 0.5, 0.6, 0.7, 0.8 or 0.9. In some embodiments, the relative shear strength can be between about 0.5 to 0.95.

[00050] FIG. 1T-V illustrate another embodiment of an implant structure 160 having a central lumen 161. Each apex 162 has a groove 163 that extends along the length of the apex 162. In some embodiments, the distal end 164 of the implant structure 160 can be tapered to facilitate implantation into the bone. In some embodiments, the implant structure 160 illustrated in FIGS. 1T-V has a relative bending strength of about 0.87 and a relative shear strength of about 0.88. In some embodiments, to load the implant structure 160 with bone graft materials, the bone graft material is applied externally to the implant structure 160 either before or during implantation. In addition to receiving the bone graft materials, the grooves 163 also function to eliminate or reduce a corner haloing effect.

[00051] In some embodiments, the grooves 163 can be circular shaped cutouts running along the apex 162 having a diameter (D5) of about 0.25 of the width of the face 165 and an arc length of about 0.28 of the width of the face 165. In some embodiments, the grooves 163 can have a diameter of greater or less than about 0.25 of the width of the face 165. In some embodiments,

the grooves 163 can have an arc length of greater than or less than about 0.28 of the width of the face 165.

[00052] In one embodiment of a lateral approach (see FIGS. 5, 6, and 7A/B), one or more implant structures 20 are introduced laterally through the ilium, the SI-Joint, and into the sacrum.

5 This path and resulting placement of the implant structures 20 are best shown in FIGS. 6 and 7A/B. In the illustrated embodiment, three implant structures 20 are placed in this manner. Also in the illustrated embodiment, the implant structures 20 are rectilinear in cross section and triangular in this case, but it should be appreciated that implant structures 20 of other cross sections can be used. In addition, any of the implant structures disclosed above can be used in  
10 the implantation procedures herein.

[00053] Before undertaking a lateral implantation procedure, the physician identifies the SI-Joint segments that are to be fixated or fused (arthrodesed) using, e.g., the Fortin finger test, thigh thrust, FABER, Gaenslen's, compression, distraction, and diagnostic SI Joint injection.

[00054] Aided by lateral, inlet, and outlet C-arm views, and with the patient lying in a prone  
15 position, the physician aligns the greater sciatic notches and then the alae (using lateral visualization) to provide a true lateral position. A 3 cm incision is made starting aligned with the posterior cortex of the sacral canal, followed by blunt tissue separation to the ilium. From the lateral view, the guide pin 38 (with sleeve (not shown)) (e.g., a Steinmann Pin) is started resting on the ilium at a position inferior to the sacrum end plate and just anterior to the sacral canal. In  
20 the outlet view, the guide pin 38 should be parallel to the sacrum end plate at a shallow angle anterior (e.g., 15 to 20 degrees off horizontal, as FIG. 7B shows). In a lateral view, the guide pin 38 should be posterior to the sacrum anterior wall. In the inlet view, the guide pin 38 should not violate the sacral foramina. This corresponds generally to the sequence shown diagrammatically in FIGS. 2A and 2B. A soft tissue protector (not shown) is desirably slipped over the guide pin  
25 38 and firmly against the ilium before removing the guide pin sleeve (not shown).

[00055] Over the guide pin 38 (and through the soft tissue protector), the pilot bore 42 is drilled in the manner previously described, as is diagrammatically shown in FIG. 2C. The pilot bore 42 extends through the ilium, through the SI-Joint, and into the sacrum. The drill bit 40 is then removed.

30 [00056] The shaped broach 44 is tapped into the pilot bore 42 over the guide pin 38 (and through the soft tissue protector) to create a broached bore 48 with the desired profile for the implant structure 20, which, in the illustrated embodiment, is triangular. This generally corresponds to the sequence shown diagrammatically in FIG. 2D. The triangular profile of the broached bore 48 is also shown in FIG. 5.

**[00057]** FIGS. 2E and 2F illustrate an embodiment of the assembly of a soft tissue protector or dilator or delivery sleeve 200 with a drill sleeve 202, a guide pin sleeve 204 and a handle 206. In some embodiments, the drill sleeve 202 and guide pin sleeve 204 can be inserted within the soft tissue protector 200 to form a soft tissue protector assembly 210 that can slide over the guide pin 208 until bony contact is achieved. The soft tissue protector 200 can be any one of the soft tissue protectors or dilators or delivery sleeves disclosed herein. In some embodiments, an expandable dilator or delivery sleeve 200 as disclosed herein can be used in place of a conventional soft tissue dilator. In the case of the expandable dilator, in some embodiments, the expandable dilator can be slid over the guide pin and then expanded before the drill sleeve 202 and/or guide pin sleeve 204 are inserted within the expandable dilator. In other embodiments, insertion of the drill sleeve 202 and/or guide pin sleeve 204 within the expandable dilator can be used to expand the expandable dilator.

**[00058]** In some embodiments, a dilator can be used to open a channel through the tissue prior to sliding the soft tissue protector assembly 210 over the guide pin. The dilator(s) can be placed over the guide pin, using for example a plurality of sequentially larger dilators or using an expandable dilator. After the channel has been formed through the tissue, the dilator(s) can be removed and the soft tissue protector assembly can be slid over the guide pin. In some embodiments, the expandable dilator can serve as a soft tissue protector after being expanded. For example, after expansion the drill sleeve and guide pin sleeve can be inserted into the expandable dilator.

**[00059]** As shown in FIGS. 5 and 6, a triangular implant structure 20 can be now tapped through the soft tissue protector over the guide pin 38 through the ilium, across the SI-Joint, and into the sacrum, until the proximal end of the implant structure 20 is flush against the lateral wall of the ilium (see also FIGS. 7A and 7B). The guide pin 38 and soft tissue protector are withdrawn, leaving the implant structure 20 residing in the broached passageway, flush with the lateral wall of the ilium (see FIG. 7A and 7B). In the illustrated embodiment, two additional implant structures 20 are implanted in this manner, as FIG. 6 best shows. In other embodiments, the proximal ends of the implant structures 20 are left proud of the lateral wall of the ilium, such that they extend 1, 2, 3 or 4 mm outside of the ilium. This ensures that the implants 1020 engage the hard cortical portion of the ilium rather than just the softer cancellous portion, through which they might migrate if there was no structural support from hard cortical bone. The hard cortical bone can also bear the loads or forces typically exerted on the bone by the implant 1020.

**[00060]** The implant structures 20 are sized according to the local anatomy. For the SI-Joint, representative implant structures 20 can range in size, depending upon the local anatomy, from about 35 mm to about 70 mm in length, and about a 7 mm inscribed diameter (i.e. a triangle

having a height of about 10.5 mm and a base of about 12 mm). The morphology of the local structures can be generally understood by medical professionals using textbooks of human skeletal anatomy along with their knowledge of the site and its disease or injury. The physician is also able to ascertain the dimensions of the implant structure 20 based upon prior analysis of the morphology of the targeted bone using, for example, plain film x-ray, fluoroscopic x-ray, or MRI or CT scanning.

**[00061]** Using a lateral approach, one or more implant structures 20 can be individually inserted in a minimally invasive fashion across the SI-Joint, as has been described. Conventional tissue access tools, obturators, cannulas, and/or drills can be used for this purpose. Alternatively, the novel tissue access tools described above and in co-pending U.S. Application No. 61/609,043, titled "TISSUE DILATOR AND PROTECTOR" and filed March 9, 2012, can also be used. No joint preparation, removal of cartilage, or scraping are required before formation of the insertion path or insertion of the implant structures 20, so a minimally invasive insertion path sized approximately at or about the maximum outer diameter of the implant structures 20 can be formed.

**[00062]** The implant structures 20 can obviate the need for autologous bone graft material, additional screws and/or rods, hollow modular anchorage screws, cannulated compression screws, threaded cages within the joint, or fracture fixation screws. Still, in the physician's discretion, bone graft material and other fixation instrumentation can be used in combination with the implant structures 20.

**[00063]** In a representative procedure, one to six, or perhaps up to eight, implant structures 20 can be used, depending on the size of the patient and the size of the implant structures 20. After installation, the patient would be advised to prevent or reduce loading of the SI-Joint while fusion occurs. This could be about a six to twelve week period or more, depending on the health of the patient and his or her adherence to post-op protocol.

**[00064]** The implant structures 20 make possible surgical techniques that are less invasive than traditional open surgery with no extensive soft tissue stripping. The lateral approach to the SI-Joint provides a straightforward surgical approach that complements the minimally invasive surgical techniques. The profile and design of the implant structures 20 minimize or reduce rotation and micromotion. Rigid implant structures 20 made from titanium alloy provide immediate post-op SI Joint stability. A bony in-growth region 24 comprising a porous plasma spray coating with irregular surfaces supports stable bone fixation/fusion. The implant structures 20 and surgical approaches make possible the placement of larger fusion surface areas designed to maximize post-surgical weight bearing capacity and provide a biomechanically rigorous implant designed specifically to stabilize the heavily loaded SI-Joint.

[00065] In some embodiments, as illustrated in FIGS. 8A and 8B, the implant structure 800 can have a rectilinear cross-sectional profile formed from a plurality of walls 802 having a thickness of approximately 2 to 3 mm, or 1 to 5 mm, or less than approximately 5, 4, 3, or 2 mm. In some embodiments, the rectilinear cross-sectional profile can be triangular, square or  
5 rectangular. In some embodiments, the implant structure 800 can have a substantially rectilinear cross-sectional profile formed by a plurality of apices that are joined together by a plurality of walls. The thin walled implant structure 800 can be advanced through the bone with little to no bony preparation. For example, in some embodiments, the implant structure 800 can be driven into the bone without first forming a bore that is shaped like the implant structure 800. In some  
10 embodiments, the distal end 804 of the implant structure 800 can be sharpened and/or have cutting edges like a chisel to facilitate the cutting of bone as the implant structure 800 is advanced. In some embodiments, an osteotome can be used to cut the bone before the implant structure 800 is inserted into the bone. For example, an osteotome as described in U.S. Provisional Application 61/800,966, titled "SYSTEMS AND METHODS FOR REMOVING  
15 AN IMPLANT" and filed on March 15, 2013, which is herein incorporated by reference in its entirety for all purposes, can be adapted to pre-cut the bone to facilitate insertion of the implant structure 800 without forming a complete bore. In some embodiments, a bore can be formed as described above, and the implant structure 800 can then be inserted into the bore.

[00066] In some embodiments, as illustrated in FIGS. 8A and 8B, the distal portion of the  
20 plurality of walls 802 forming the implant structure 800 can have fenestrations 806. For example, the distal portion of the implant structure 800 that is configured to be embedded in the sacrum or second bone segment can be fenestrated, while the proximal portion of the implant structure 800 that is configured to be embedded in the ilium or first bone segment can be free from fenestrations. In other embodiments, the proximal portion of the implant structure 800 can  
25 be fenestrated while the distal portion of the implant structure 800 can be free from fenestration. In other embodiments, as illustrated in FIGS. 9A and 9B and the other embodiments described herein, the fenestrations can be distributed across the entire face of each wall or side of the implant structure. In some embodiments, the concentration or number of fenestrations can be higher in one portion of the implant structure than the other.

[00067] In some embodiments, as illustrated in FIGS. 8A and 8B, the fenestrations 806 can be  
30 oval or circular shaped or curvilinear, such that the fenestrations 806 do not have corners. In some embodiments, the fenestrations 806 can be staggered, arranged randomly, or otherwise distributed in a non-aligned pattern across each wall 802. For example, in some embodiments, each longitudinal row of fenestrations can be staggered or offset from adjacent longitudinal rows  
35 of fenestrations. In some embodiments, the fenestrations can alternatively or additionally be



staggered along the longitudinal axis of the implant structure 800. This non-aligned arrangement of fenestrations can provide the implant structure with improved structural strength.

[00068] In some embodiments, the implant structure 800 can be sized as any other implant structure described herein. In some embodiments, the implant structure 800 can be sized so that  
5 the implant structure 800 has walls that inscribe a circle with a diameter of about 8 mm, or between about 4 and 12 mm, as illustrated in FIG. 8B. In some embodiments, the implant structure 800 can be sized so that the wall inscribe a circle with a diameter equal to or about equal to the diameter of a guide pin. In some embodiments, the implant structure 800 can have a proximal end 808 having a cap 810 with a circular opening 812 that allows passage of a guide  
10 pin.

[00069] In some embodiments, as illustrated in FIGS. 9A and 9B, the implant structure 900 can be similar to the embodiment described in FIG. 8A and 8B except that the fenestrations 902 are evenly distributed across the faces of the implant structure. FIG. 9B illustrates bone growing within and/or through the fenestrations 902 and lumen of the implant structure 900. In some  
15 embodiments, the bone illustrated within the lumen of the implant structure 900 may be native bone that remains after the implant structure 900 is advanced into the bone, i.e. a self-grafting implant. In some embodiments, the lumen of the implant structure 900 illustrated in FIGS. 9A and 9B, as well as the other implant structures described herein, can be filled with bone material and/or a biologic aid such as morselized bone, allograft bone, autograft bone, hydroxyapatite,  
20 bone morphogenetic protein and the like to promote bony ingrowth within the implant structure 900. This can be appropriate when the implant structure 900 is inserted into a bore such that after implantation, the lumen of the implant structure 900 is empty or substantially empty and can be filled with bone growth promoting materials. In addition, as described above, the interior surface and/or the outer surface of the implant structure can be roughened and/or coated, using a  
25 plasma coating process for example, to provide a porous or roughened surface.

[00070] The terms “about” and “approximately” and the like can mean within 10, 20, or 30 % of the stated value or range.

[00071] Variations and modifications of the devices and methods disclosed herein will be readily apparent to persons skilled in the art. As such, it should be understood that the foregoing  
30 detailed description and the accompanying illustrations, are made for purposes of clarity and understanding, and are not intended to limit the scope of the invention, which is defined by the claims appended hereto. Any feature described in any one embodiment described herein can be combined with any other feature of any of the other embodiments whether preferred or not.

[00072] It is understood that the examples and embodiments described herein are for  
35 illustrative purposes only and that various modifications or changes in light thereof will be

suggested to persons skilled in the art and are to be included within the spirit and purview of this application and scope of the appended claims. All publications, patents, and patent applications cited herein are hereby incorporated by reference for all purposes.

**CLAIMS**

What is claimed is:

1. An implant for bone fixation, the implant comprising:  
5 an elongate body having a longitudinal axis and a rectilinear cross section transverse to the longitudinal axis, a plurality of faces, a plurality of apices joining the plurality of faces, a central lumen extending along the longitudinal axis of the elongate body, and a plurality of holes with openings on the plurality of faces, wherein the holes are in fluid communication with the central lumen.
- 10 2. The implant of claim 1, wherein the holes are circular.
3. The implant of claim 1, wherein the holes are oval.
- 15 4. The implant of claim 1, wherein the holes are arranged in a single longitudinal row on each face.
5. The implant of claim 1, wherein the holes are arranged in a plurality of longitudinal rows on each face.
- 20 6. The implant of claim 1, wherein the elongate body is coated with a biologic aid.
7. The implant of claim 1, wherein the holes have a diameter that is about equal to the diameter of the central lumen.
- 25 8. The implant of claim 1, wherein the holes have a diameter than is between about 0.2 to 0.5 of the width of the faces.
9. An implant for bone fixation, the implant comprising:  
30 an elongate body having a longitudinal axis and a rectilinear cross section transverse to the longitudinal axis, a plurality of faces, a plurality of apices joining the plurality of faces, a central lumen extending along the longitudinal axis of the elongate body, and a plurality of side pockets extending along a portion of each of the plurality of faces, wherein the side pockets have a depth that does not extend to the central lumen.

35

10. The implant of claim 9, wherein each of the plurality of faces has only one side pocket.
11. The implant of claim 9, wherein each of the side pockets is centered on each of the faces.
- 5 12. The implant of claim 9, wherein the side pockets have a width that is between about 0.2 to 0.8 of the width of the faces and a length that is between about 0.5 to 0.9 of the length of the faces.
- 10 13. The implant of claim 9, further comprising a plurality of holes located within the side pockets, wherein the holes are in fluid communication with the central lumen.
14. An implant for bone fixation, the implant comprising:  
an elongate body having a longitudinal axis and a rectilinear cross section transverse to the longitudinal axis, a plurality of faces, a plurality of apices joining the plurality of faces, and  
15 a central lumen extending along the longitudinal axis of the elongate body, wherein each one of the plurality of apices includes a groove that extends along the length of the apex.
15. An implant for bone fixation, the implant comprising:  
an elongate body having a longitudinal axis and a rectilinear cross section transverse to  
20 the longitudinal axis, a plurality of faces, a plurality of apices joining the plurality of faces, and a central lumen extending along the longitudinal axis of the elongate body, wherein each one of the plurality of apices includes a plurality of pockets located at discrete points along the length of each apex.
- 25 16. An implant for bone fixation, the implant comprising:  
an elongate body having a longitudinal axis, a distal end, a proximal end, and a rectilinear cross section transverse to the longitudinal axis, a plurality of faces, each face formed from a wall with a thickness between about 2 to 3 mm in thickness, and a plurality of fenestrations disposed on each face.
- 30 17. The implant of claim 16, wherein the distal end of the elongate body is formed into one or more cutting edges.
18. The implant of claim 16, wherein the rectilinear cross section has three sides.
- 35

19. The implant of claim 16, wherein the rectilinear cross section has four sides.
20. The implant of claim 16, wherein the fenestrations are located on a distal portion of the elongate body that is configured to be implanted within the sacrum of a patient while the proximal portion of the elongate body that is configured to be implanted within the ilium is free from fenestrations.
21. The implant of claim 16, wherein the fenestrations are arranged in a staggered pattern.
22. The implant of claim 16, further comprising a cap on the proximal end of the elongate body, the cap having a hole sized to receive a guide pin.
23. The implant of claim 16, wherein the elongate body has an inner surface and an outer surface that are porous.
24. The implant of claim 16, wherein the elongate body has an inner surface and an outer surface that are roughened.
25. The implant of claim 16, wherein the elongate body has an inner surface and an outer surface that are plasma coated.
26. The implant of claim 16, wherein the elongate body has an inner surface and an outer surface that are coated with a biologic aid.
27. The implant of claim 26, wherein the biologic aid is a bone morphogenetic protein.

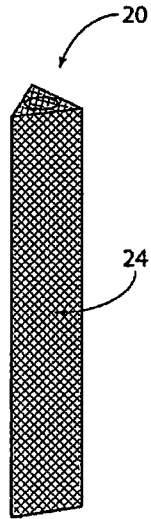

FIG. 1A

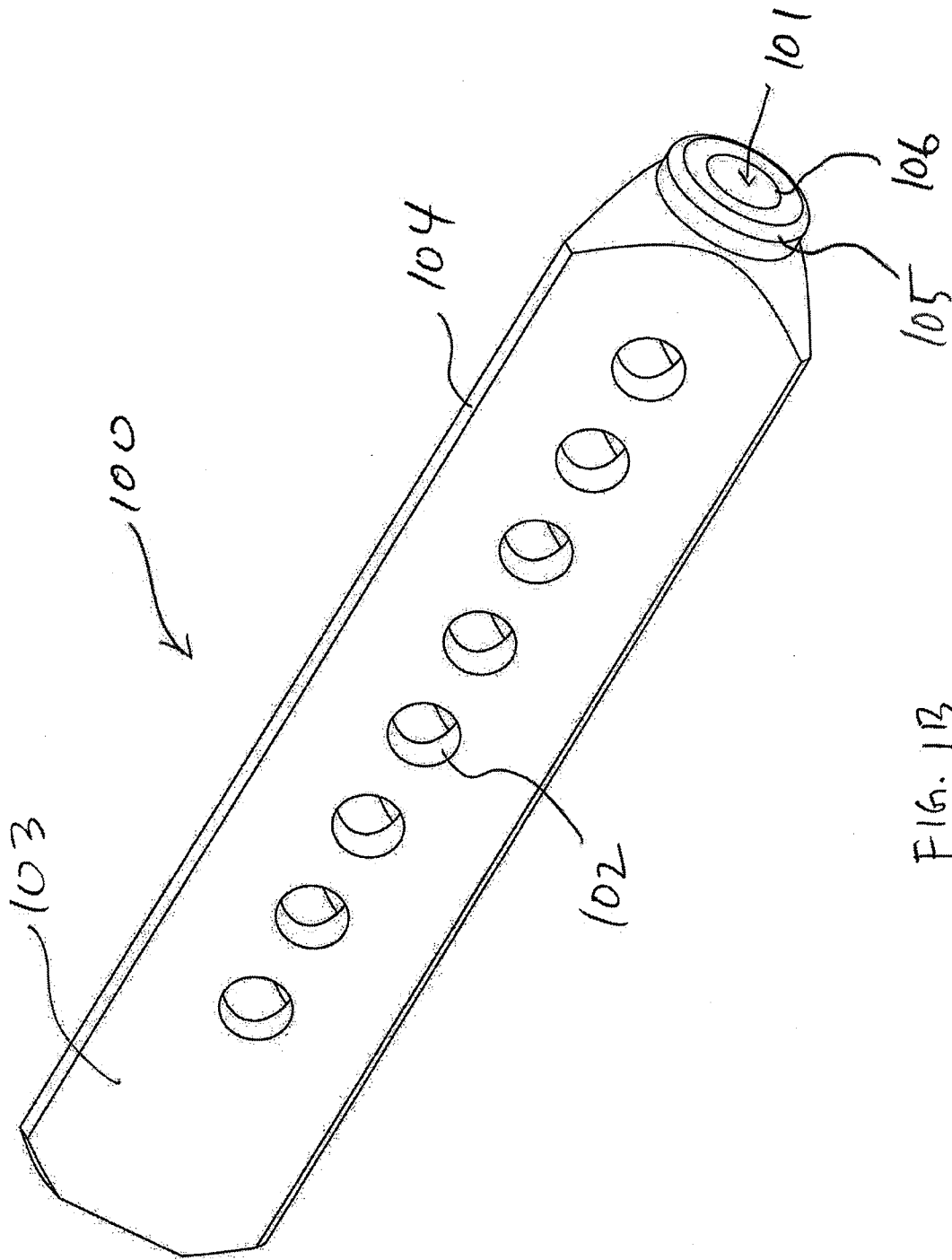

FIG. 1B

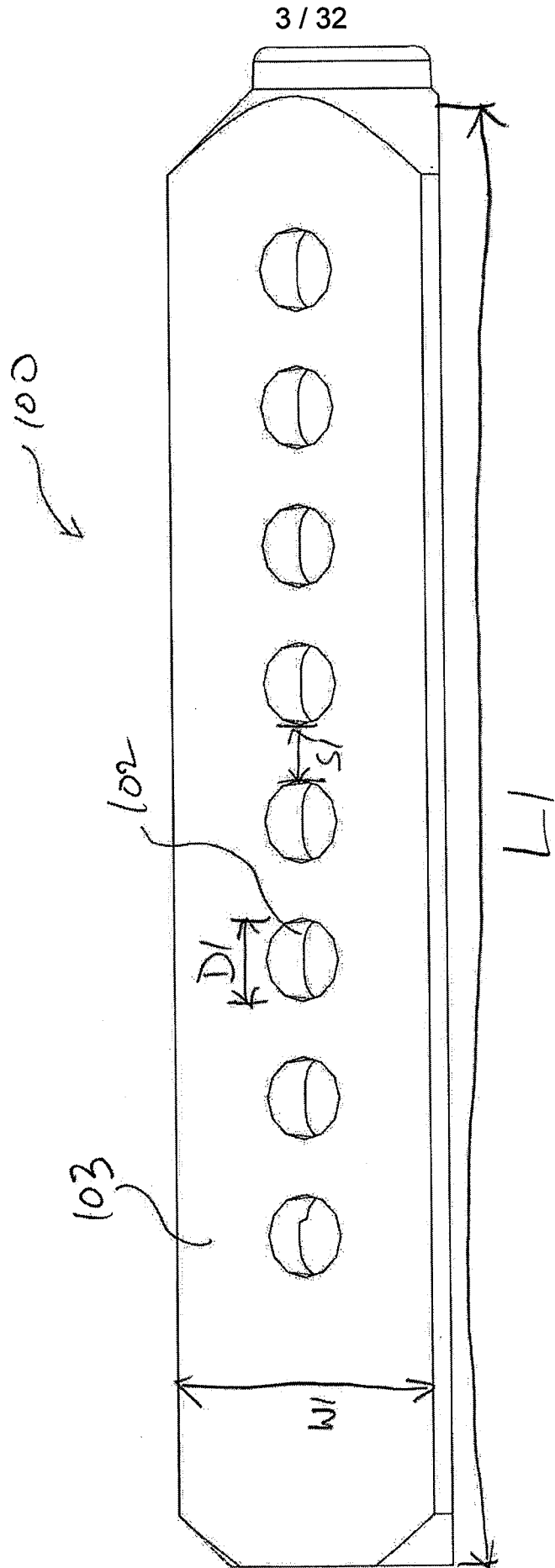

FIG. 1C



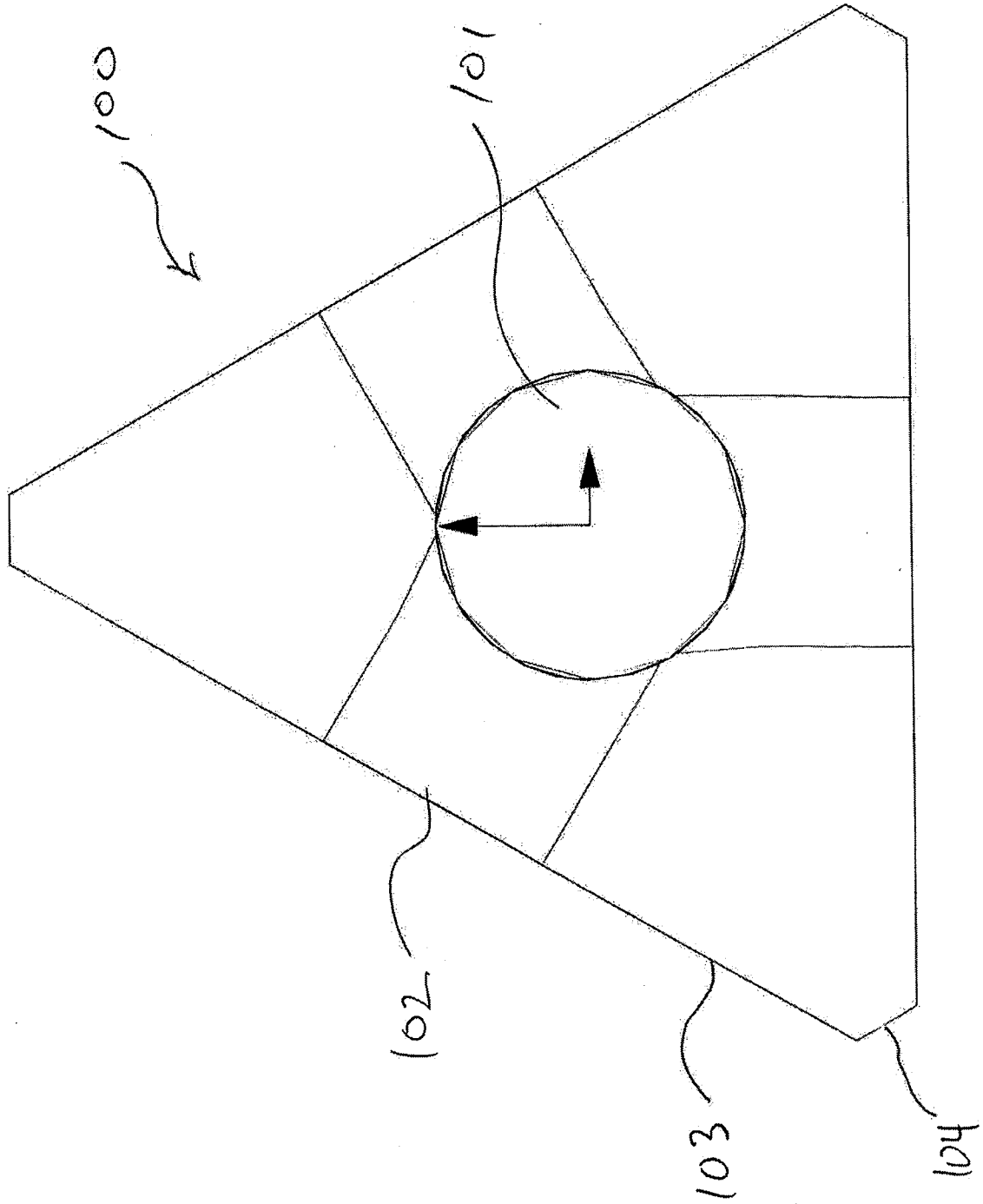

FIG. 1D

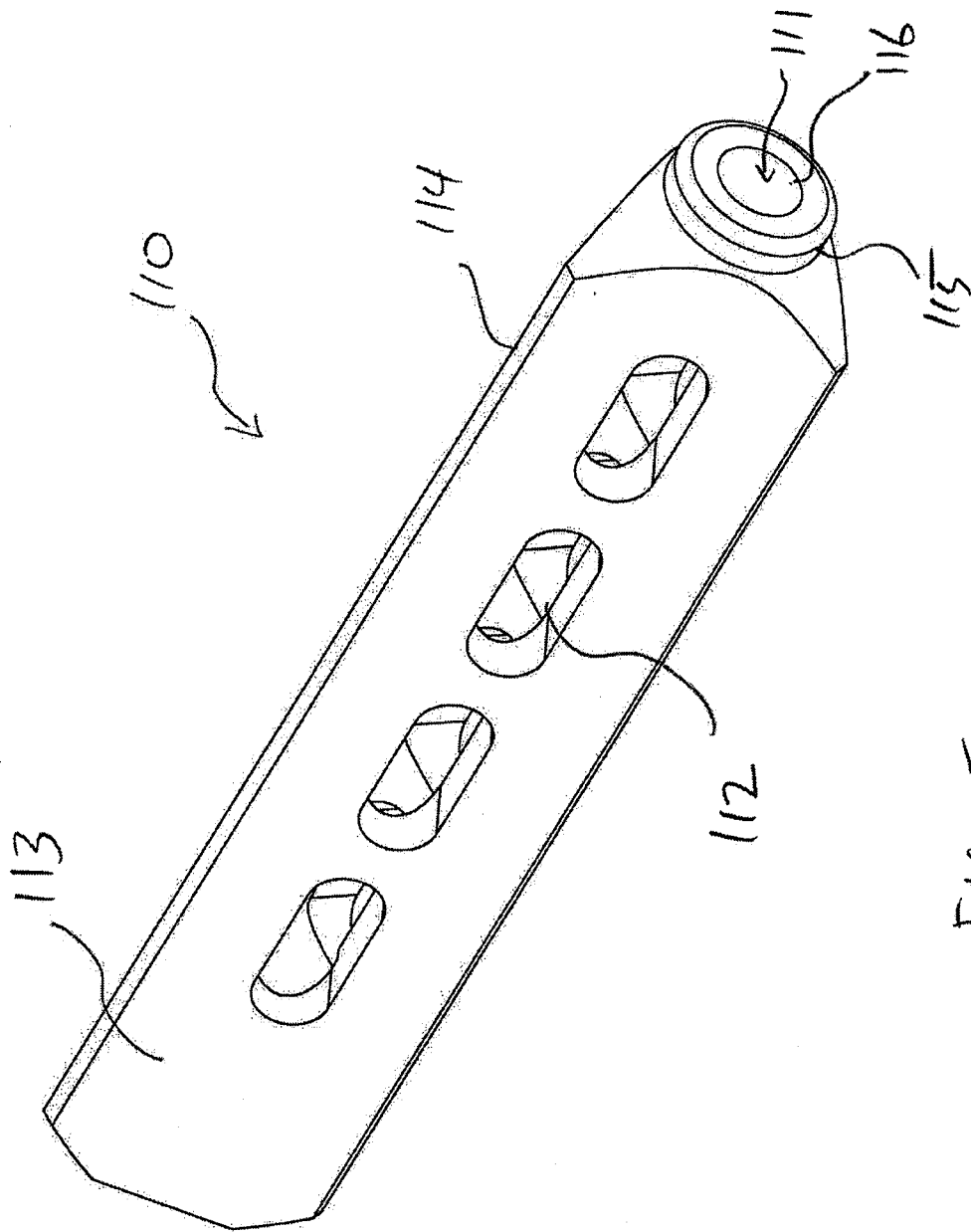

FIG. 1E

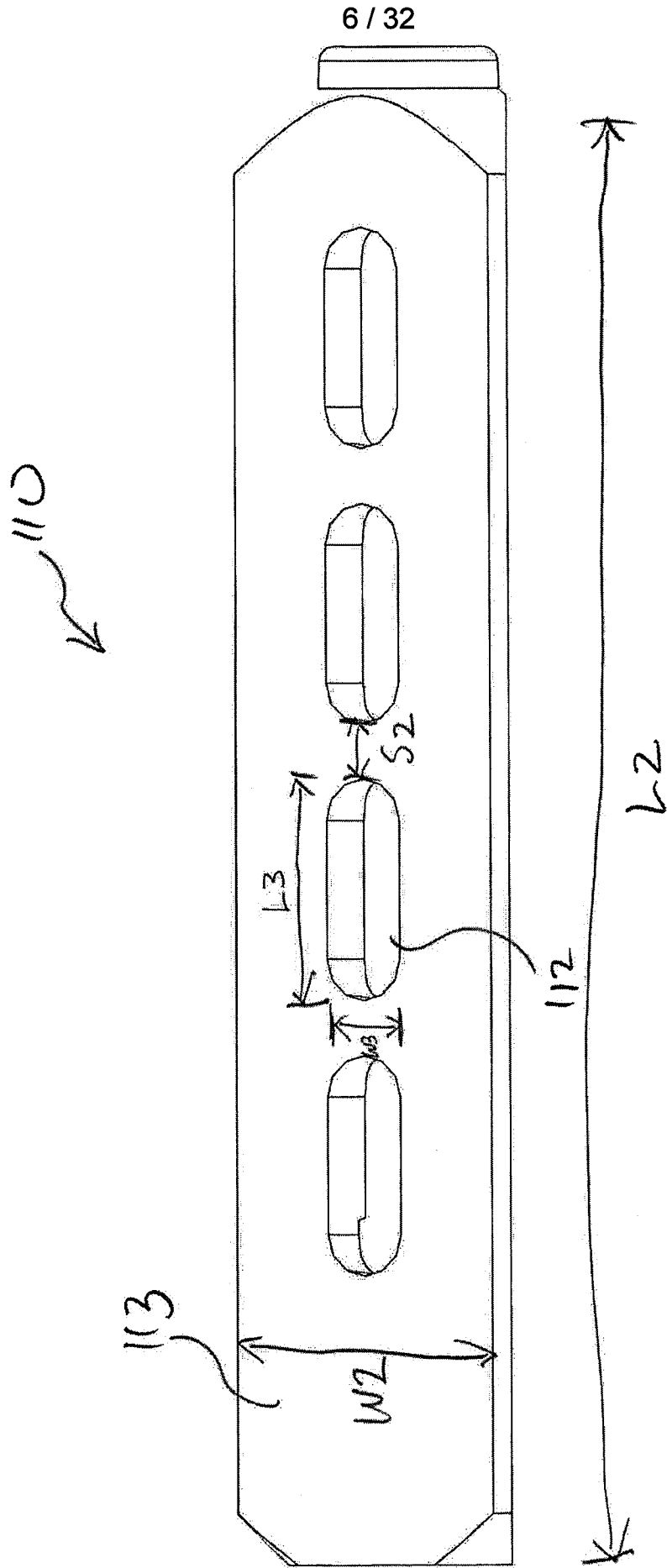

FIG. 1F

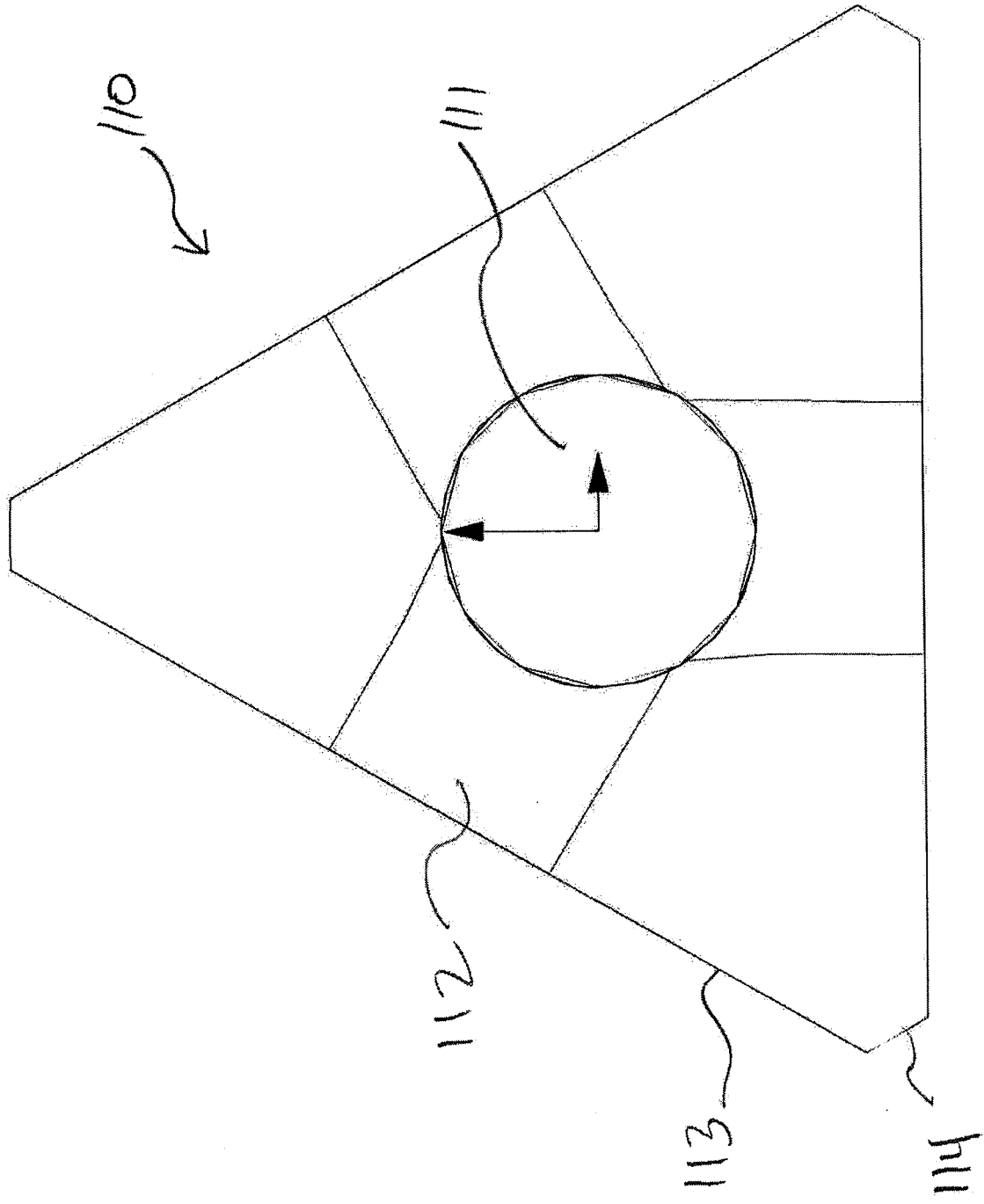

FIG. 16

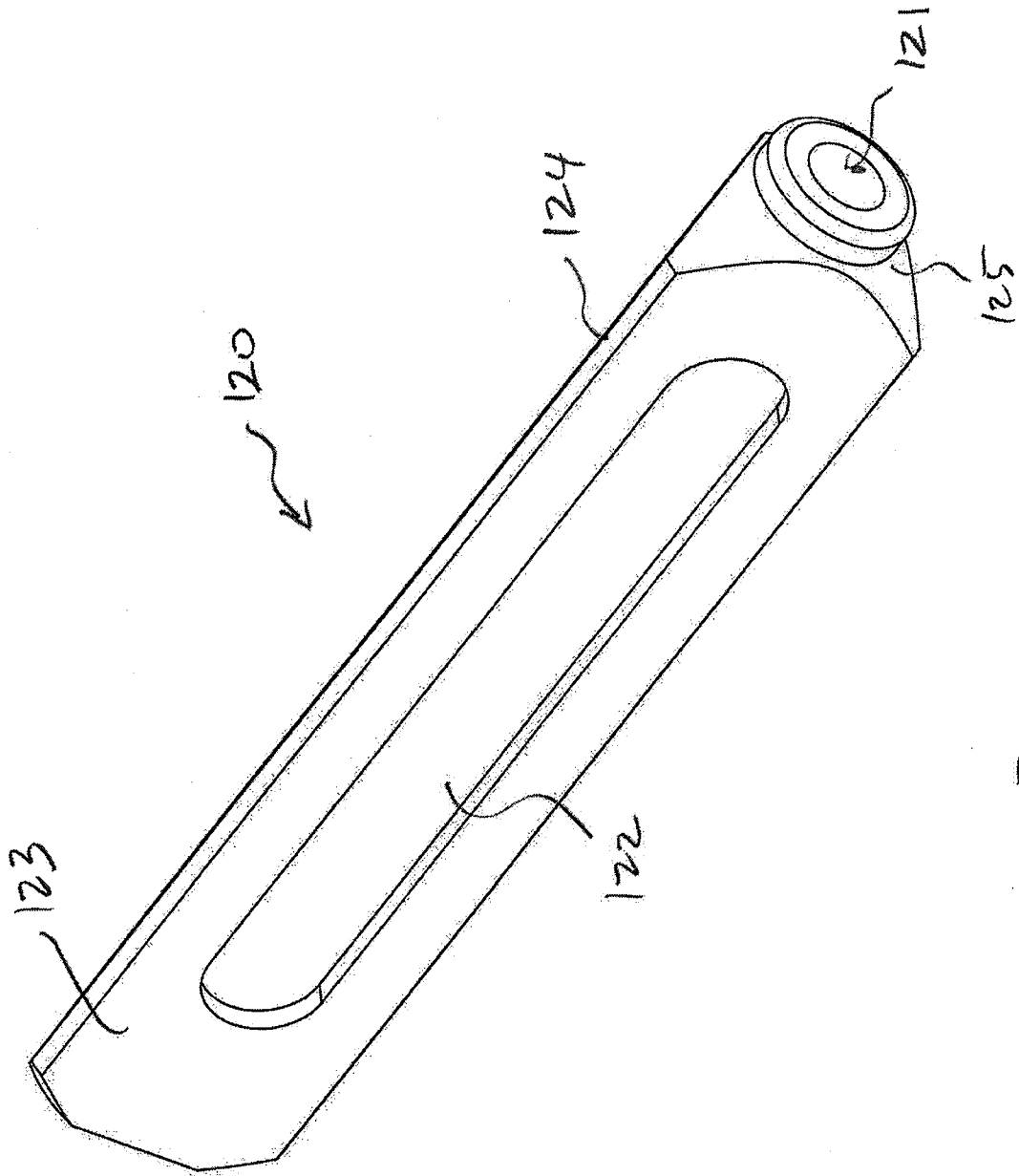

FIG. 1H

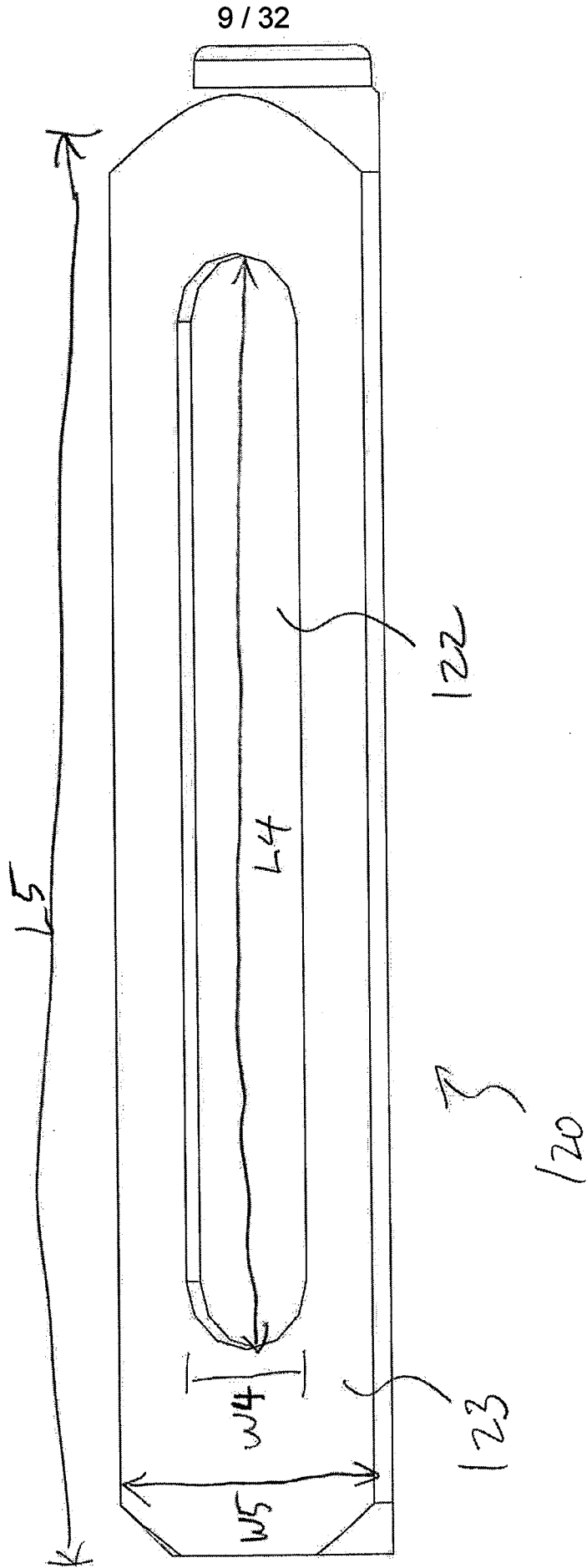

FIG. 11

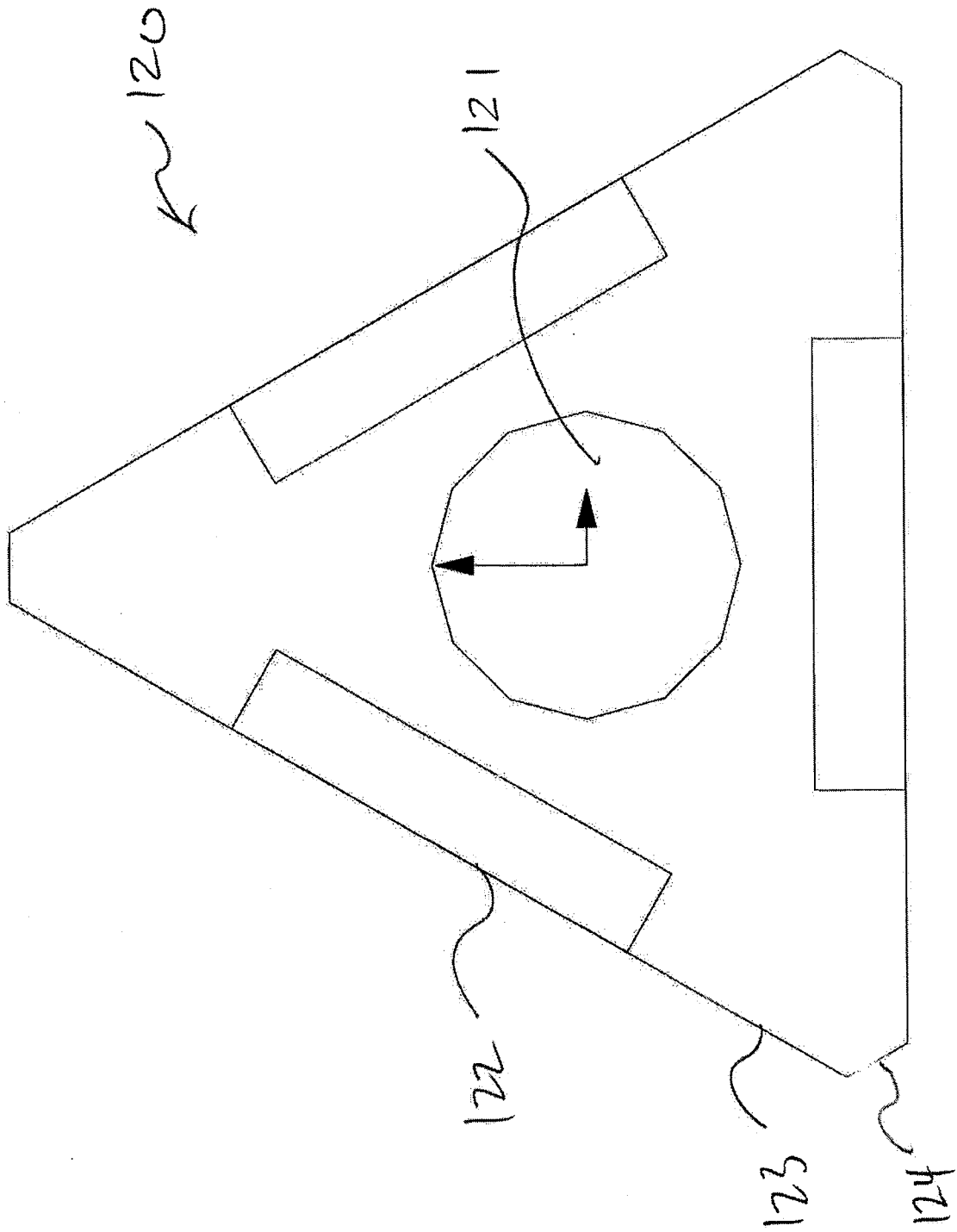

FIG. 1J

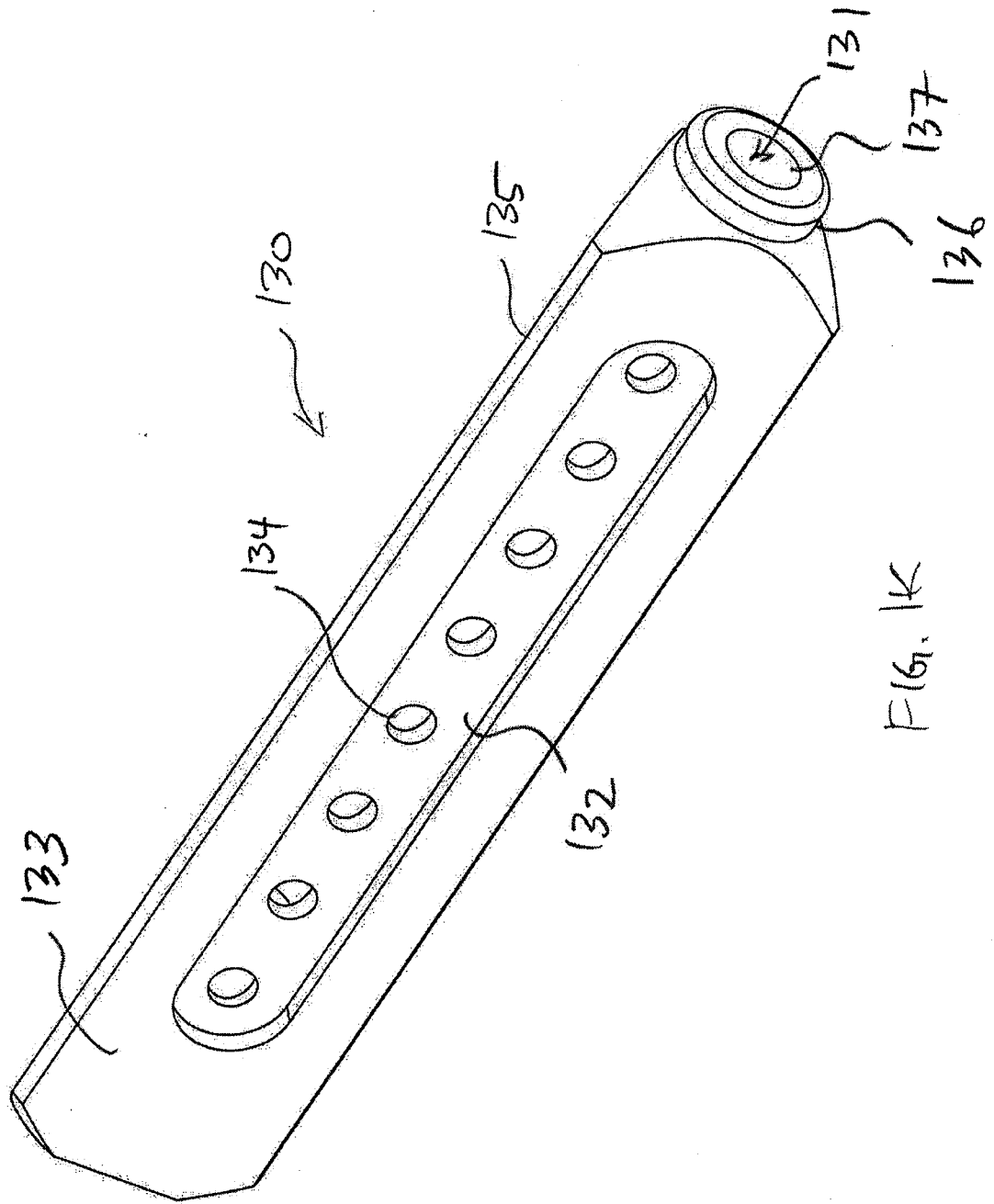

FIG. 1K



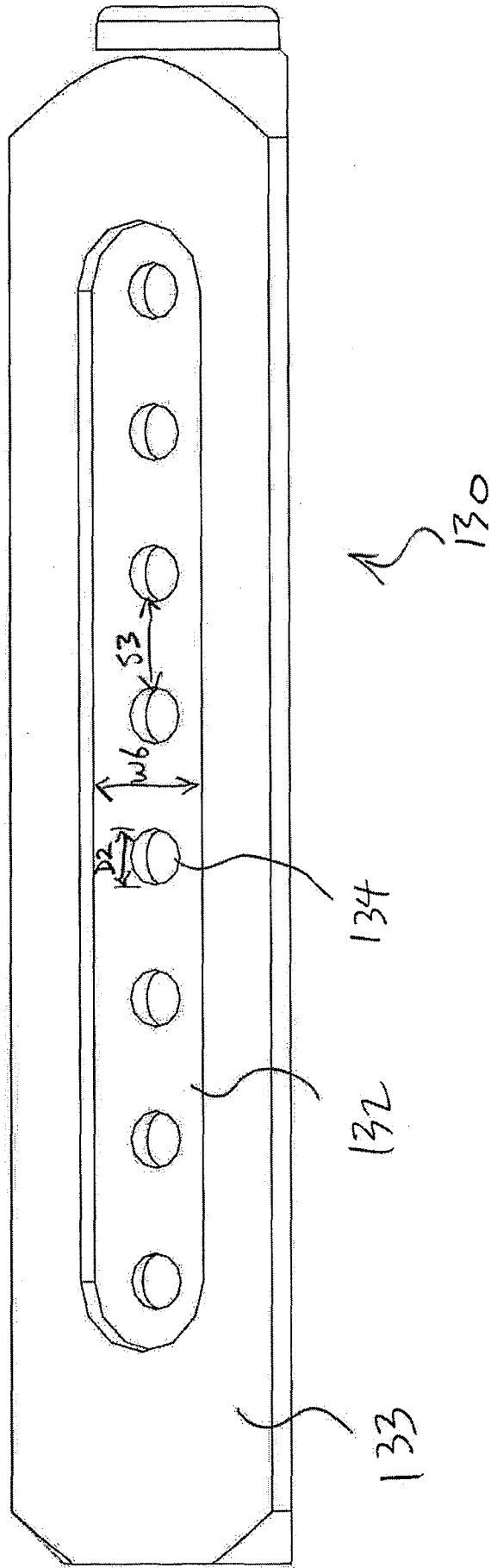
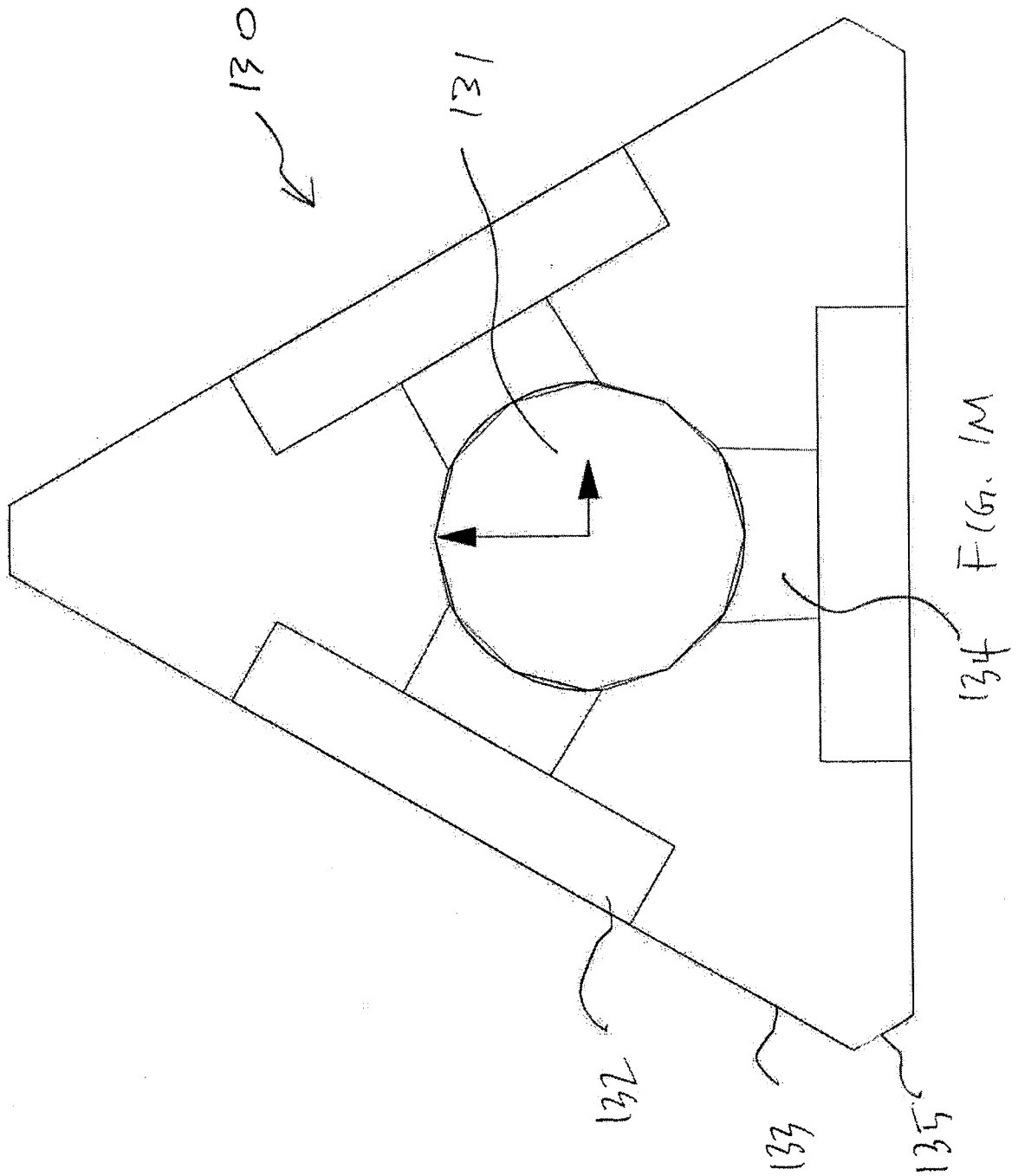
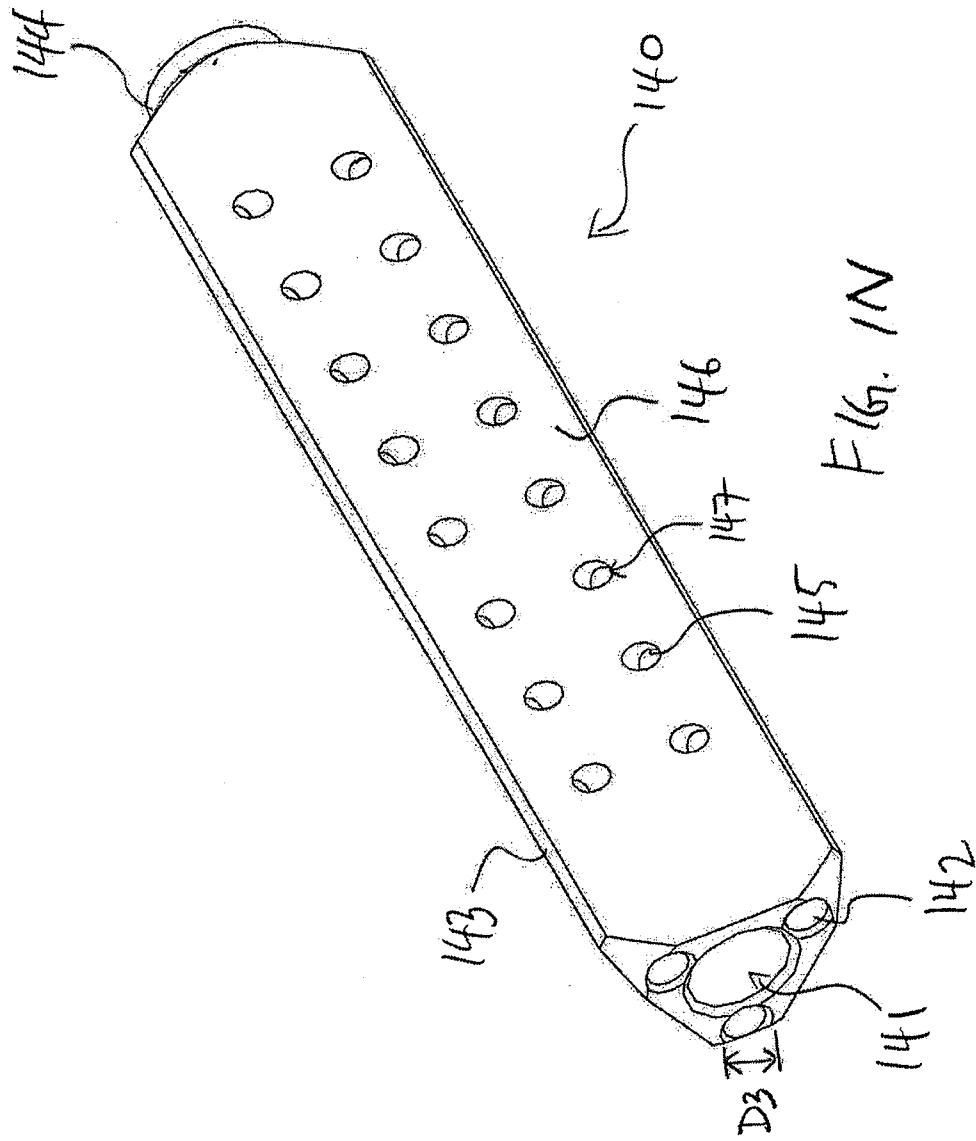

FIG. 1L



134 FIG. 1M



15 / 32

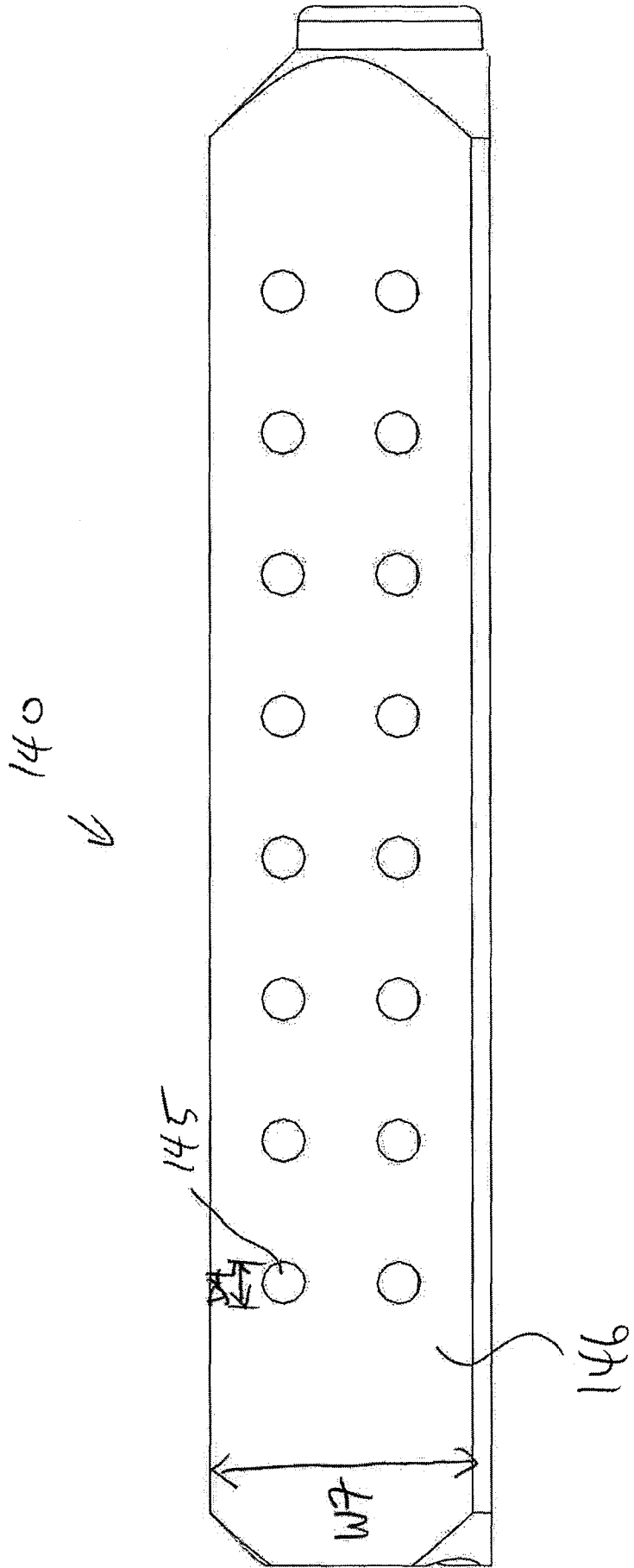
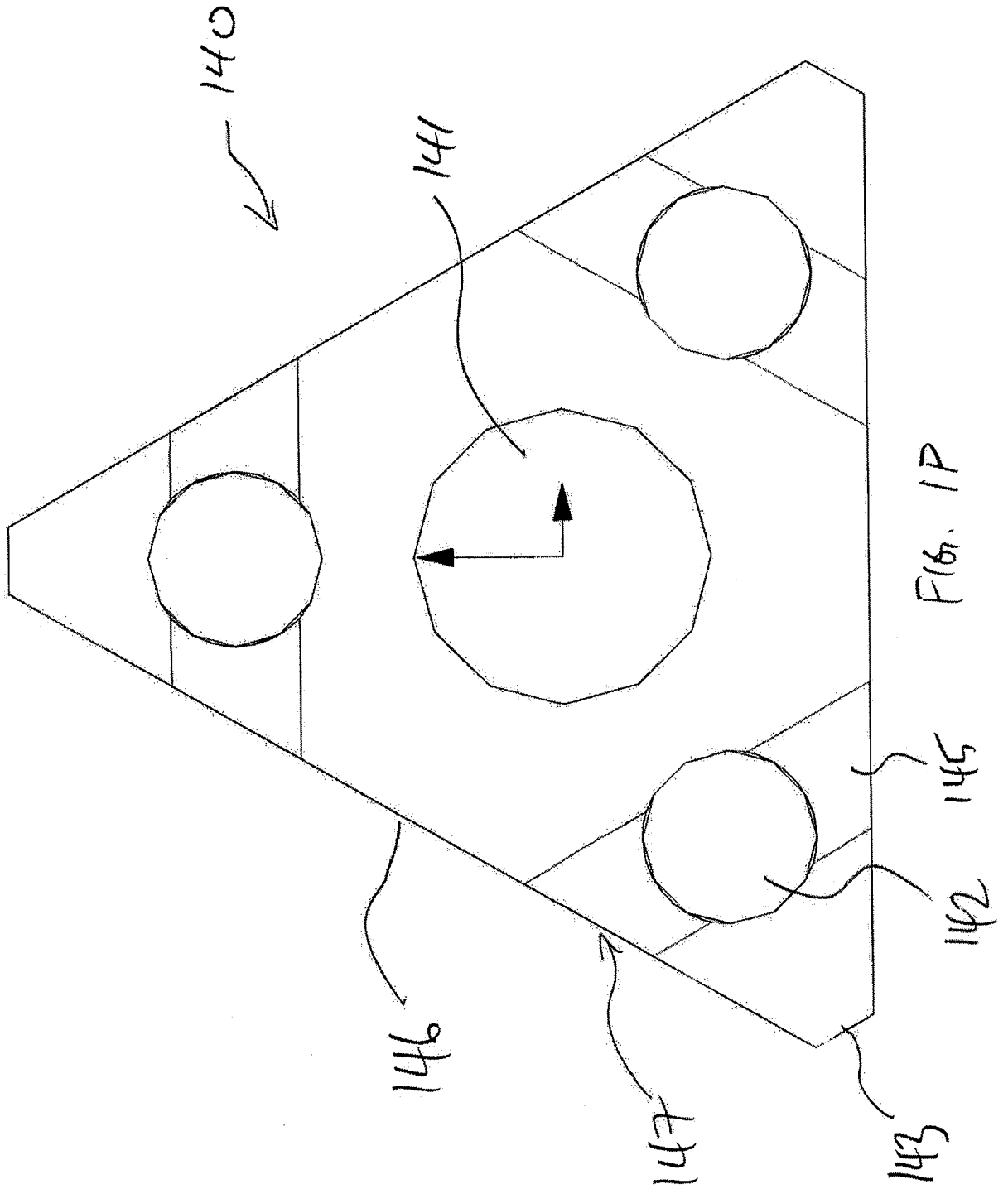

FIG. 10



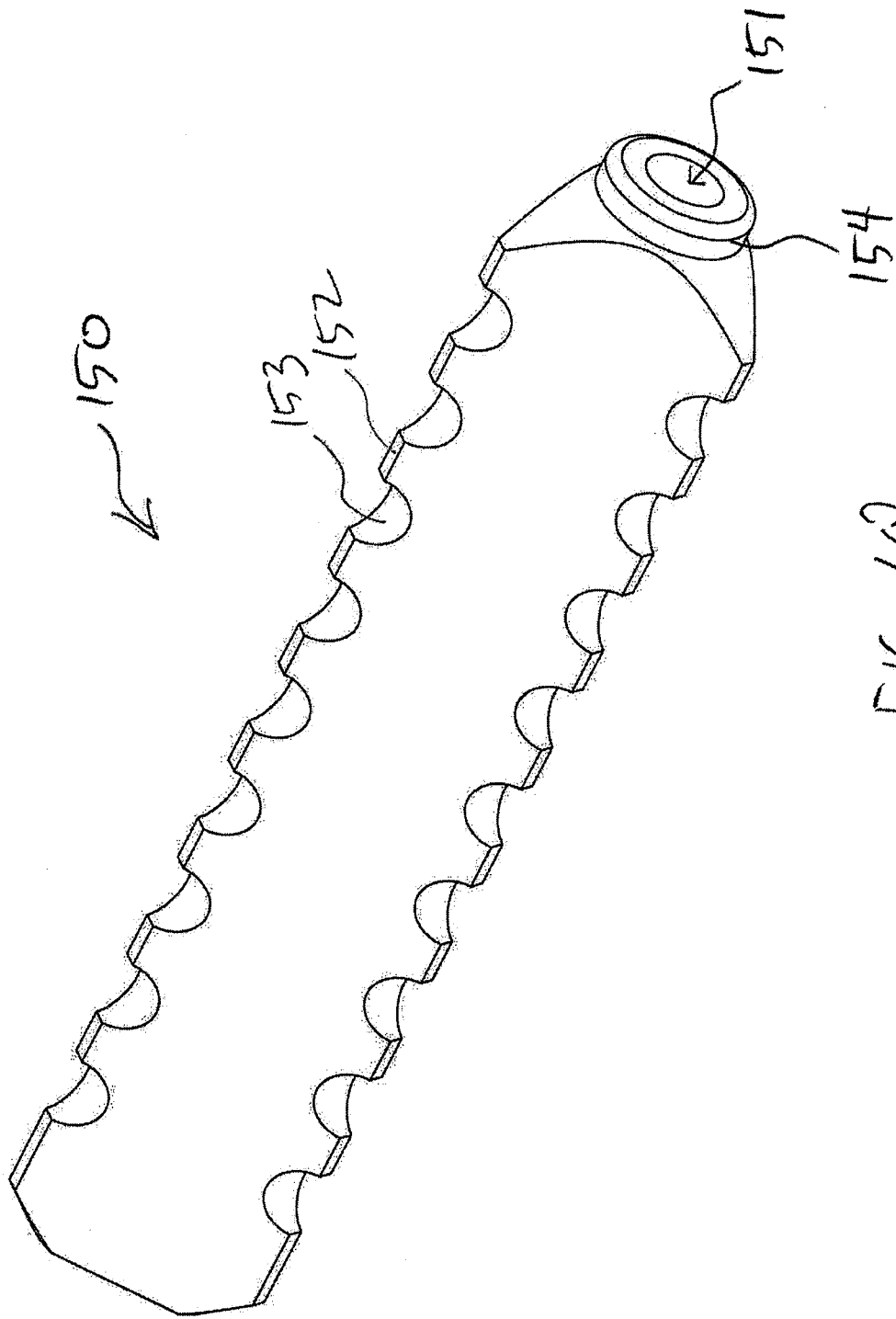

FIG. 10

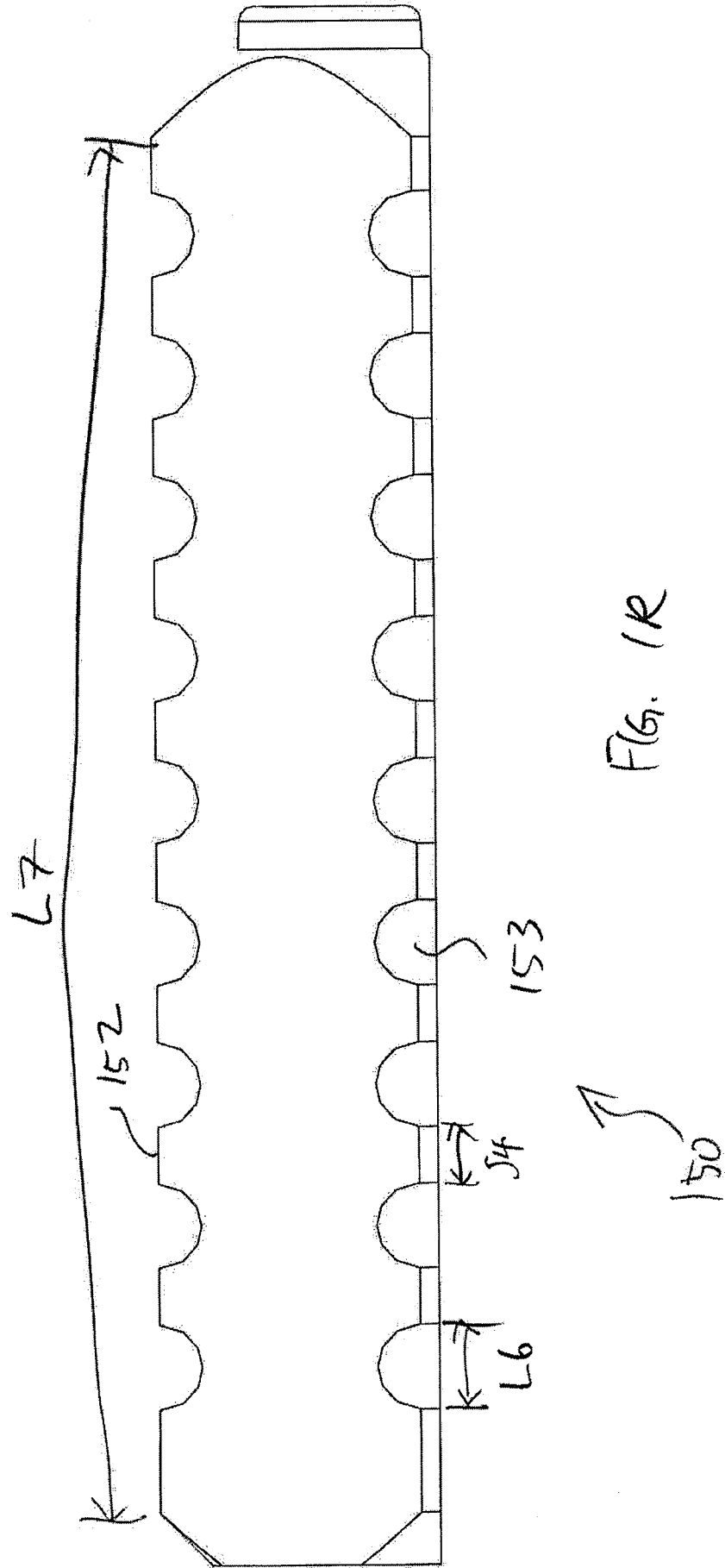

FIG. 1R

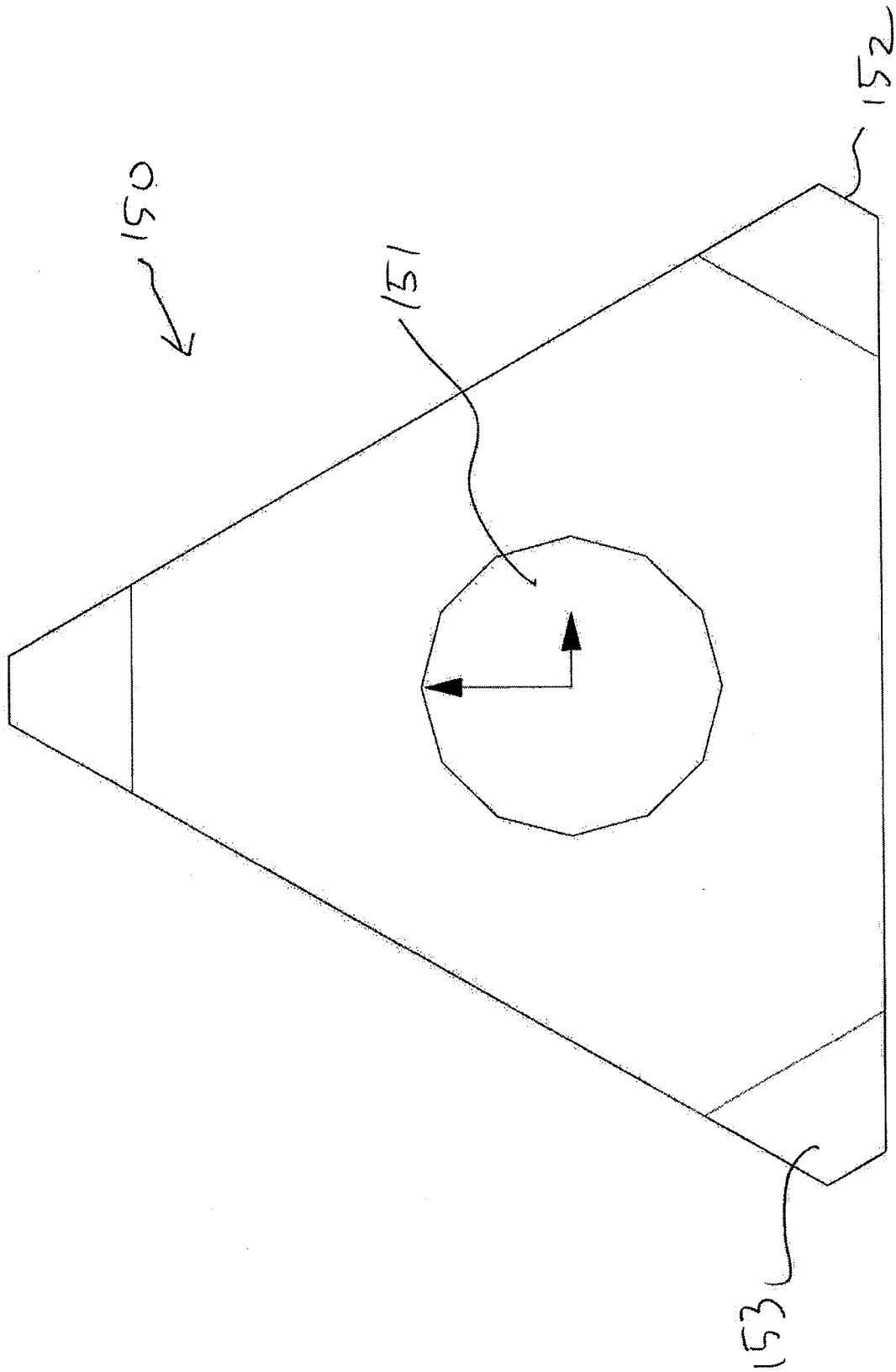

Fig. 15



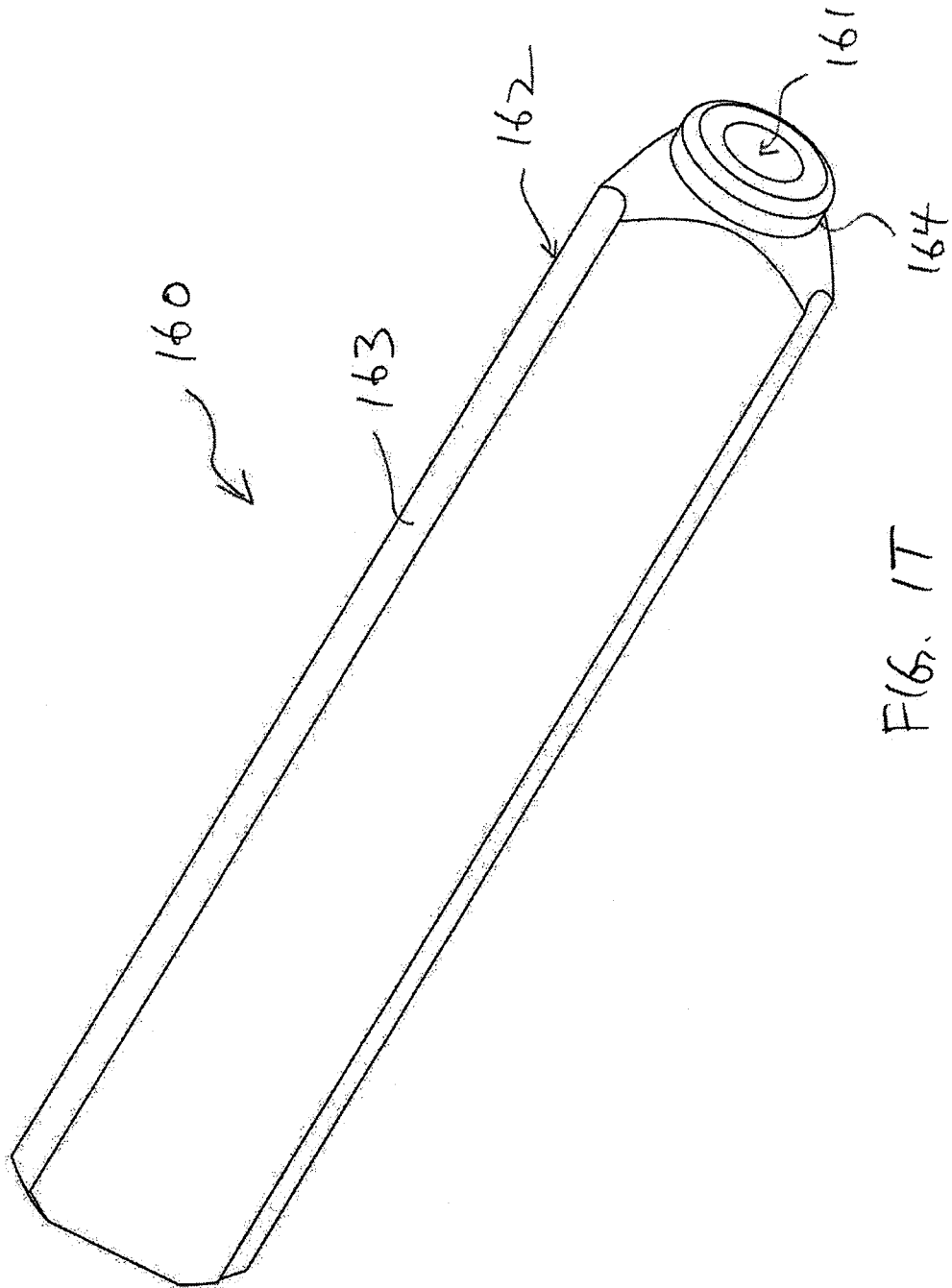

FIG. 17

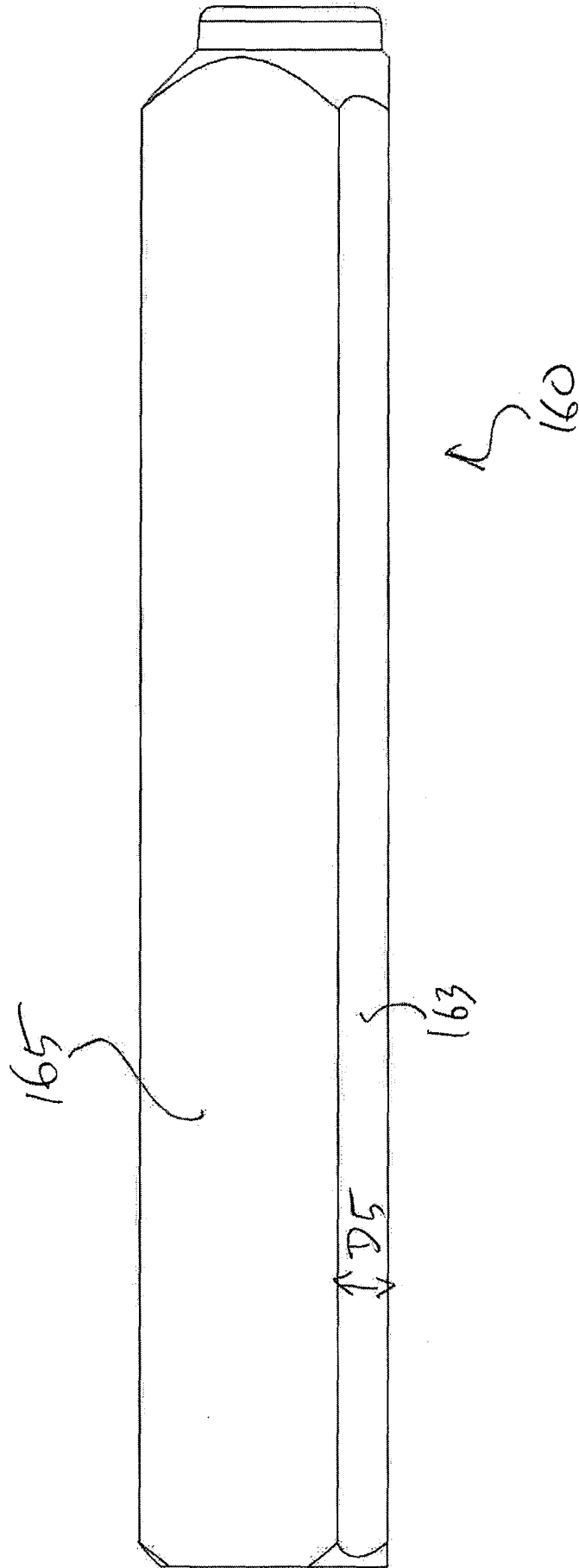

FIG. 1U

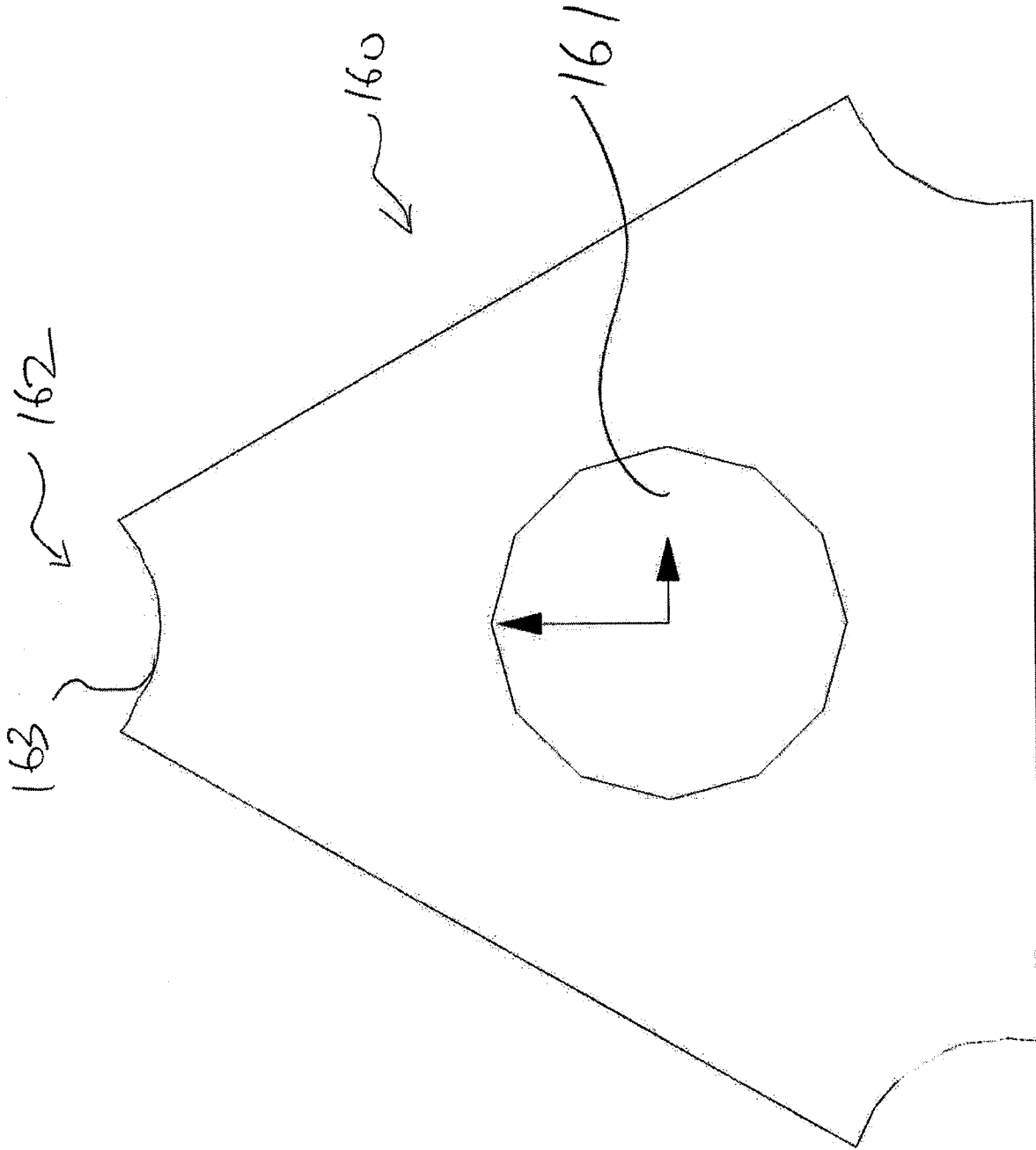

Fig. 1V

FIG. 2A

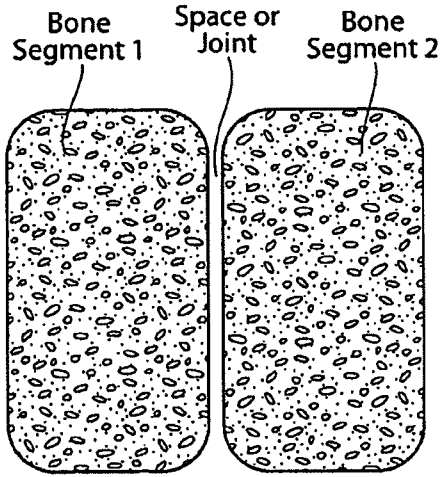

FIG. 2B

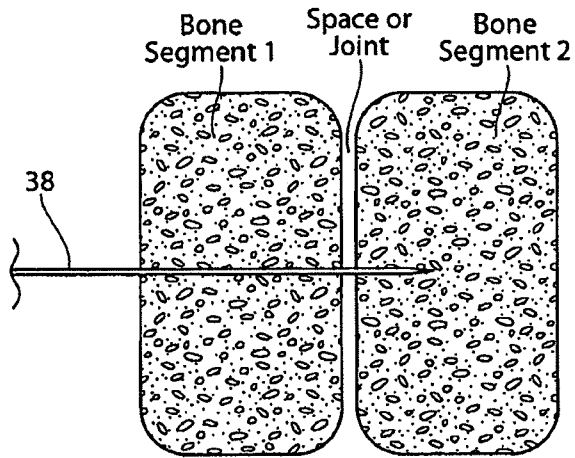

FIG. 2C

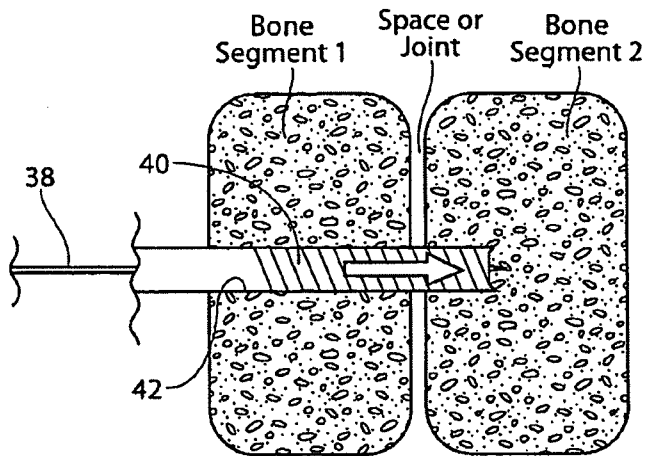
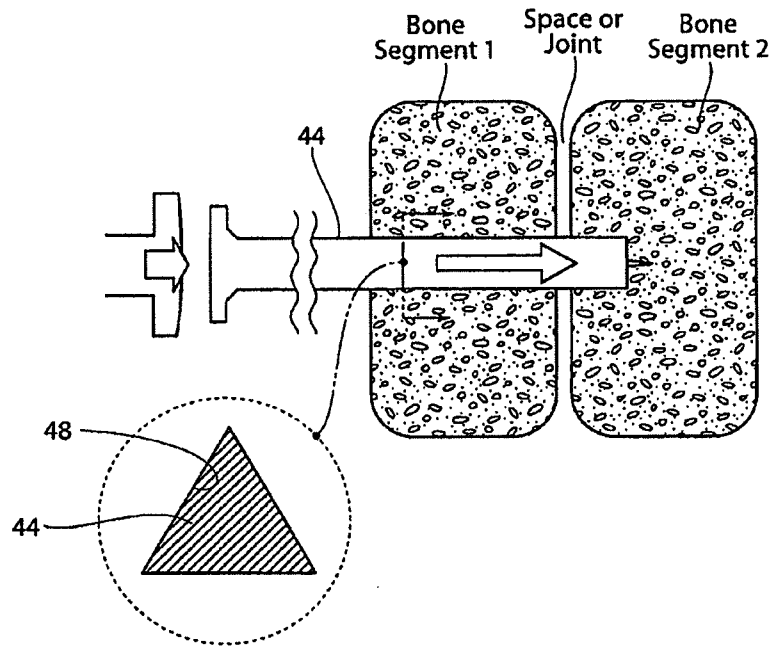

FIG. 2D



# Placement of Soft Tissue Protector and/or Dilator

Optionally slide dilator(s) over pin.

- Assemble Soft Tissue Protector, or expandable dilator or delivery sleeve, Drill Sleeve and Pin Sleeve together  
Remove dilator(s) if appropriate.
- Slide bony contact is

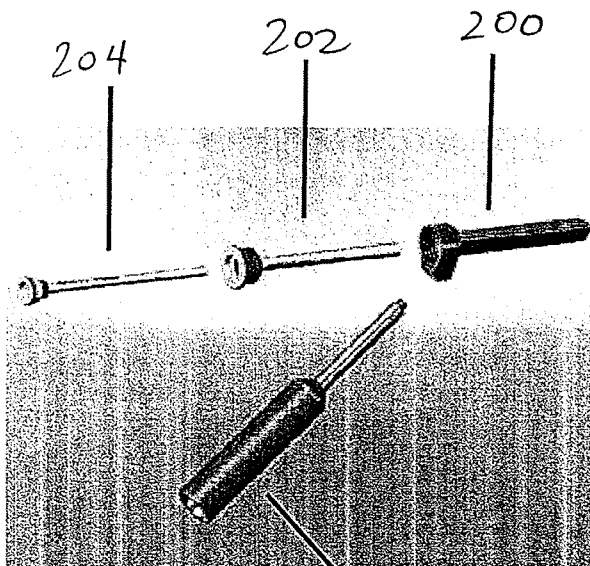

FIG. 2E

206

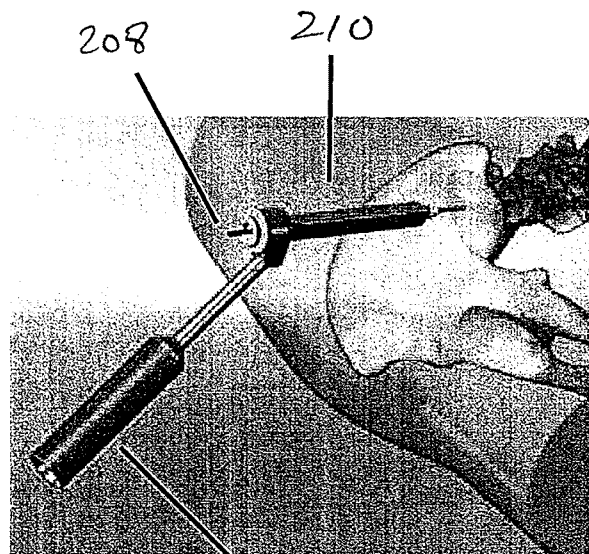

FIG. 2F

206

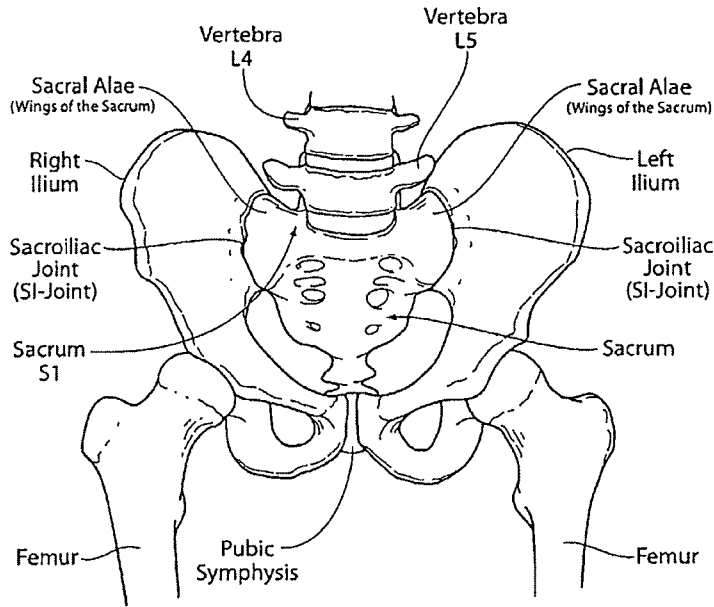

FIG. 3  
(Anterior)

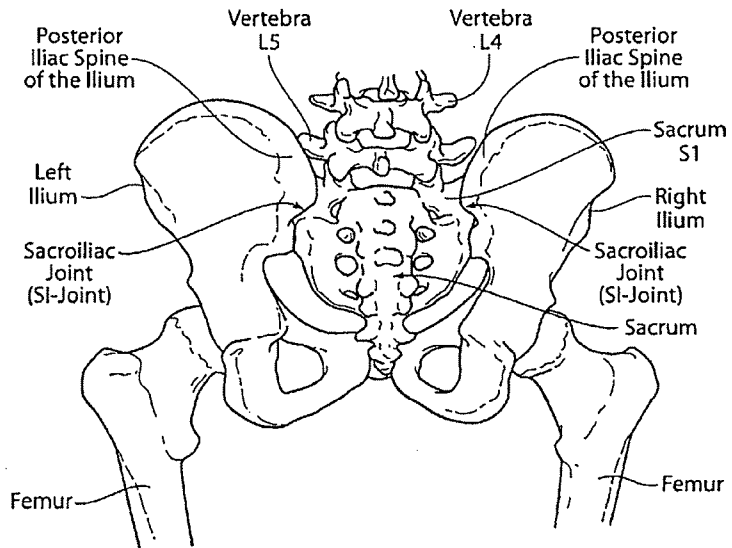

FIG. 4  
(Posterior)

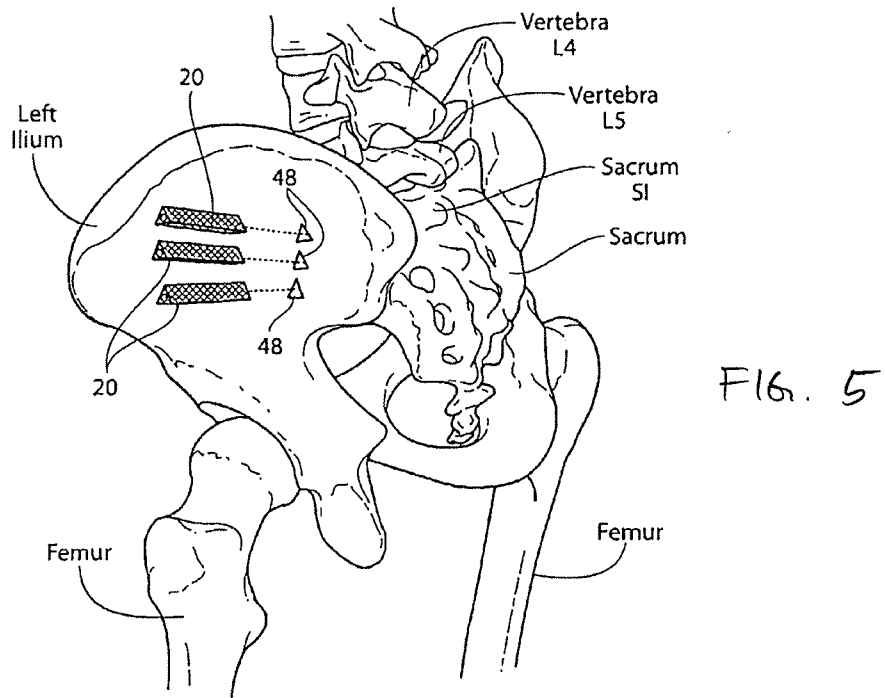

FIG. 5

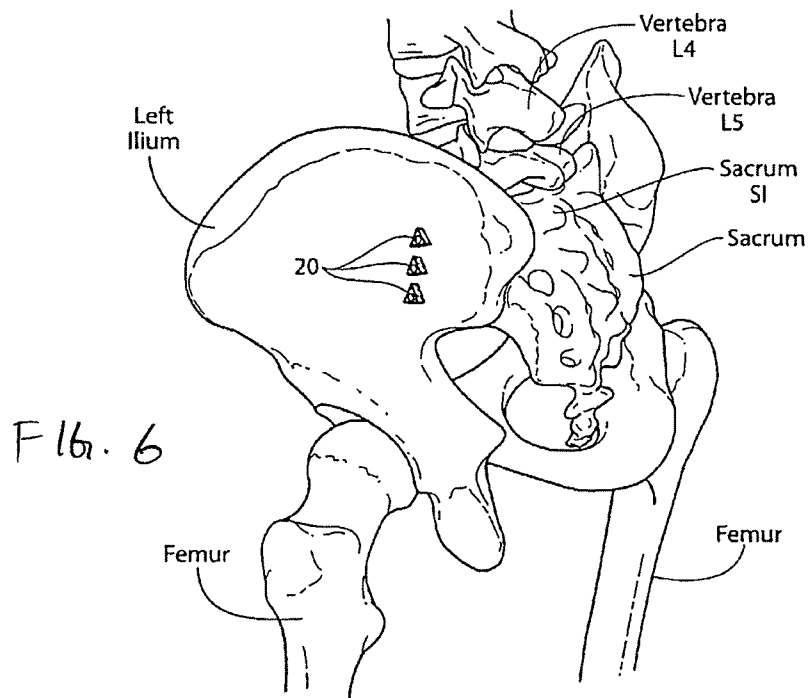

FIG. 6



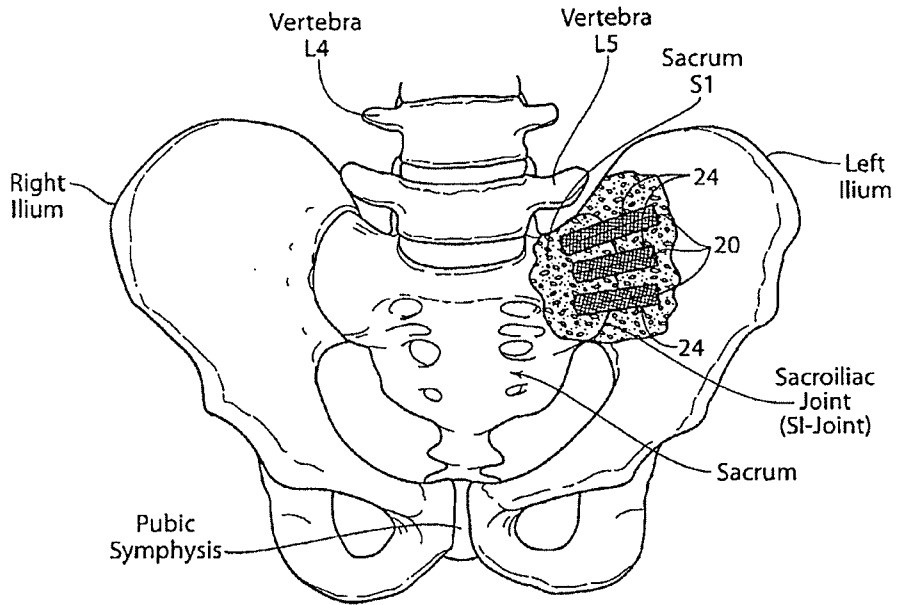

FIG. 7A

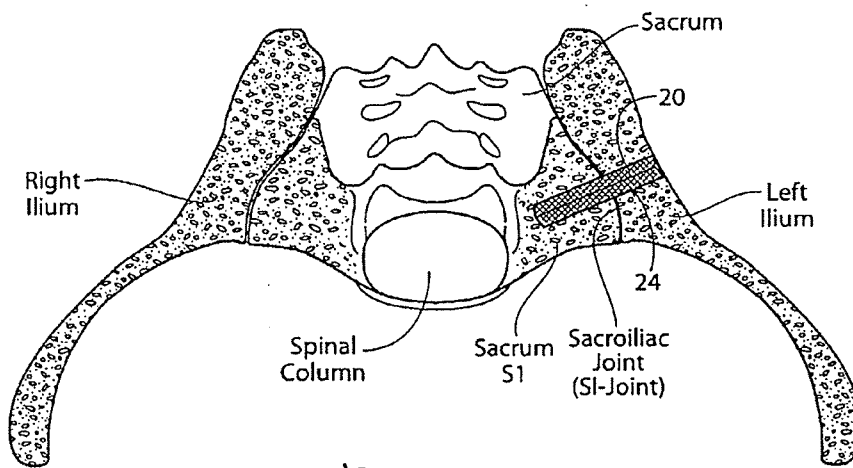

FIG. 7B

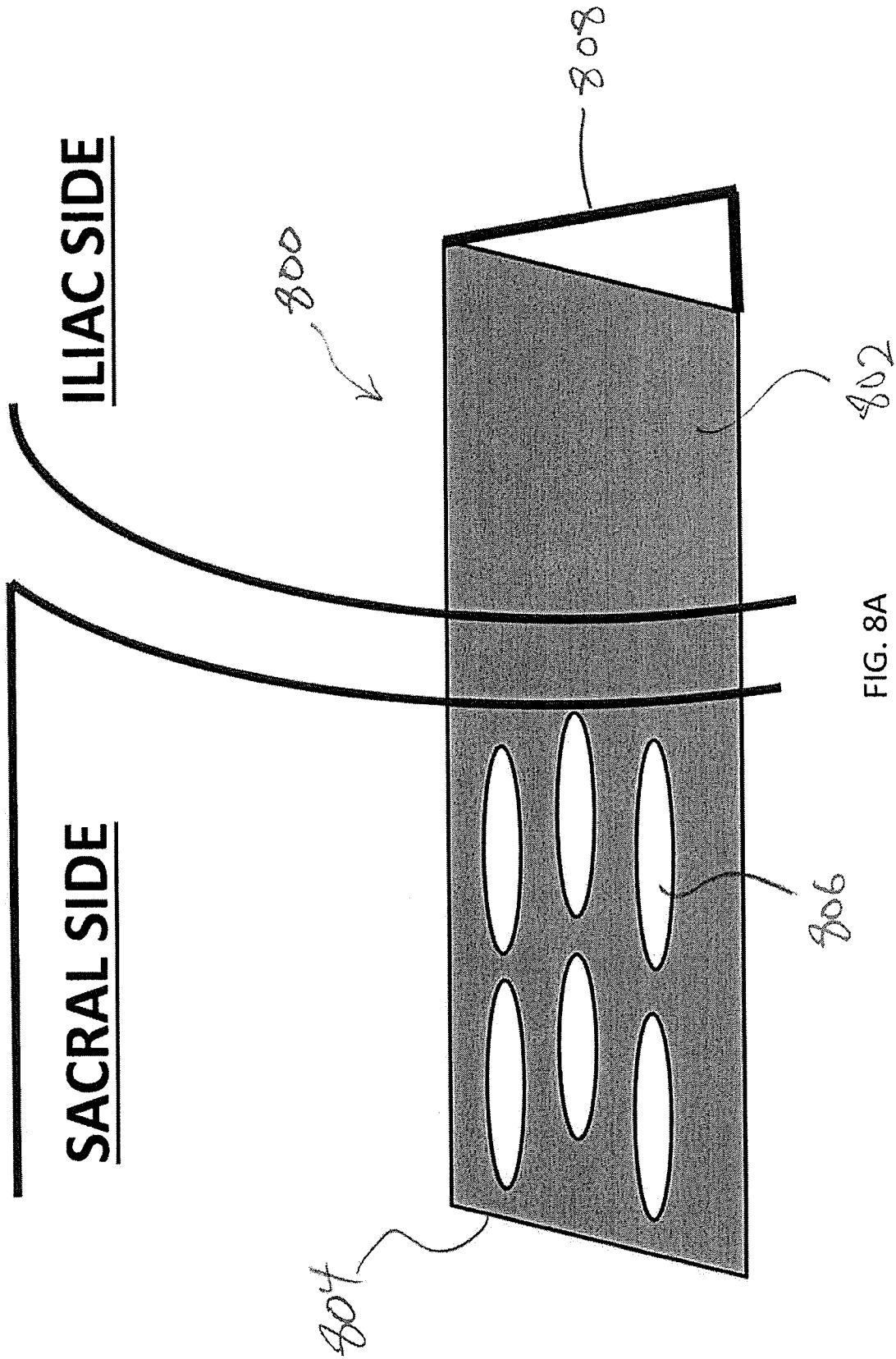

FIG. 8A

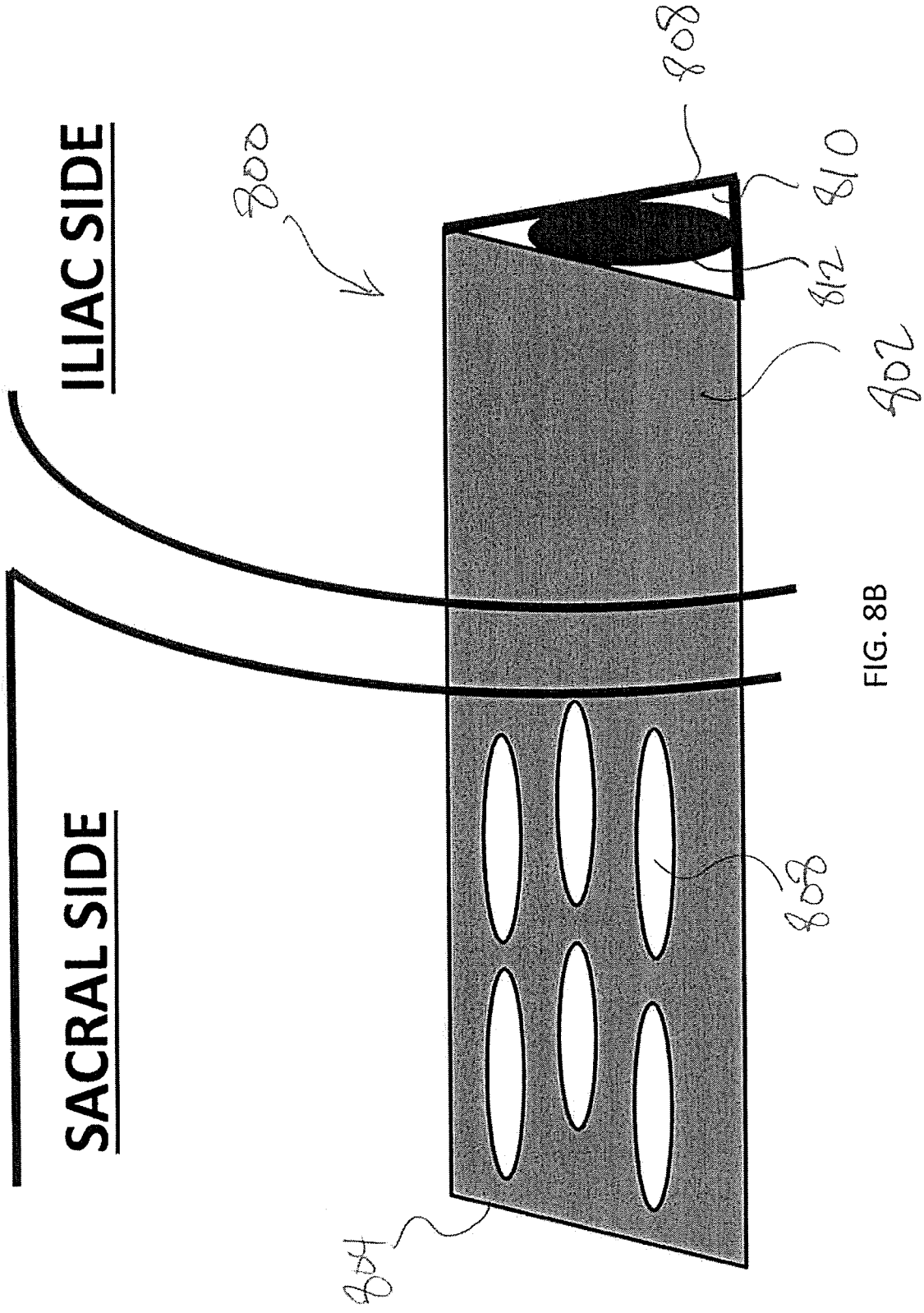

FIG. 8B

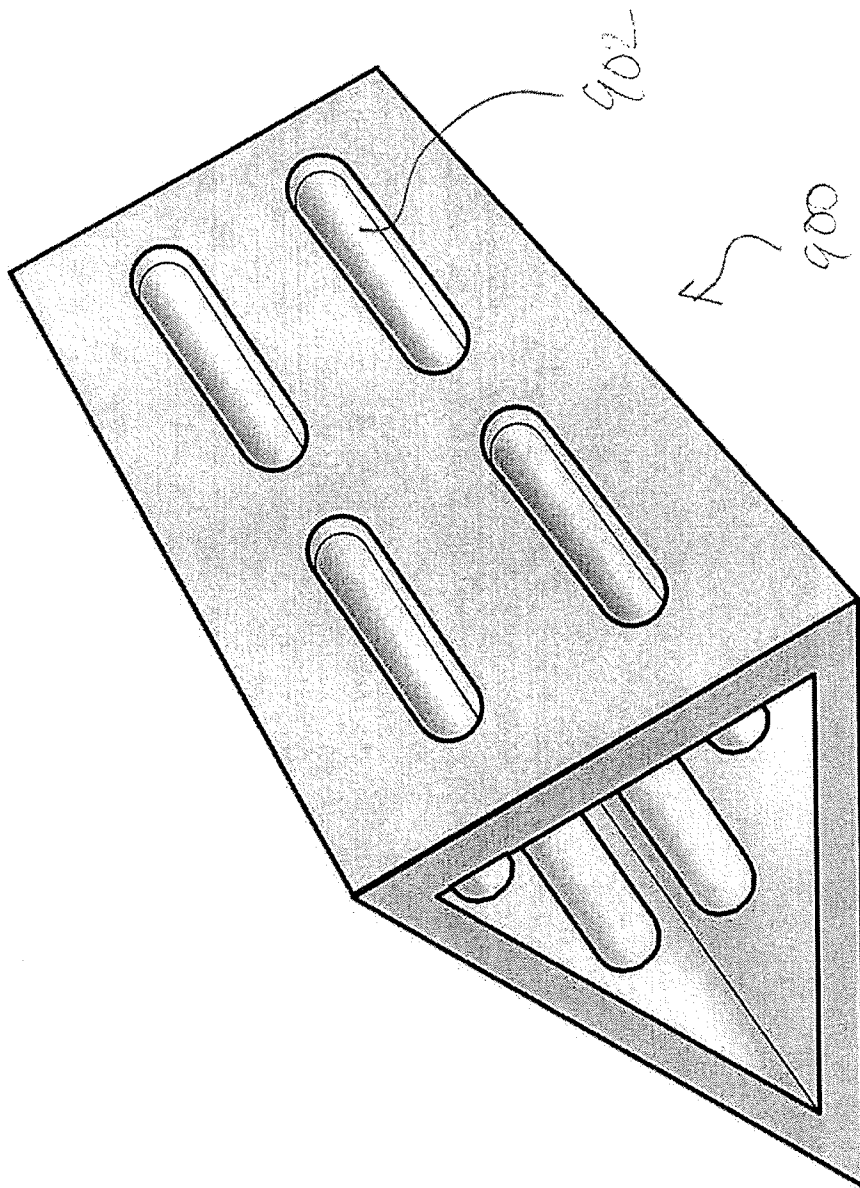

FIG. 9A

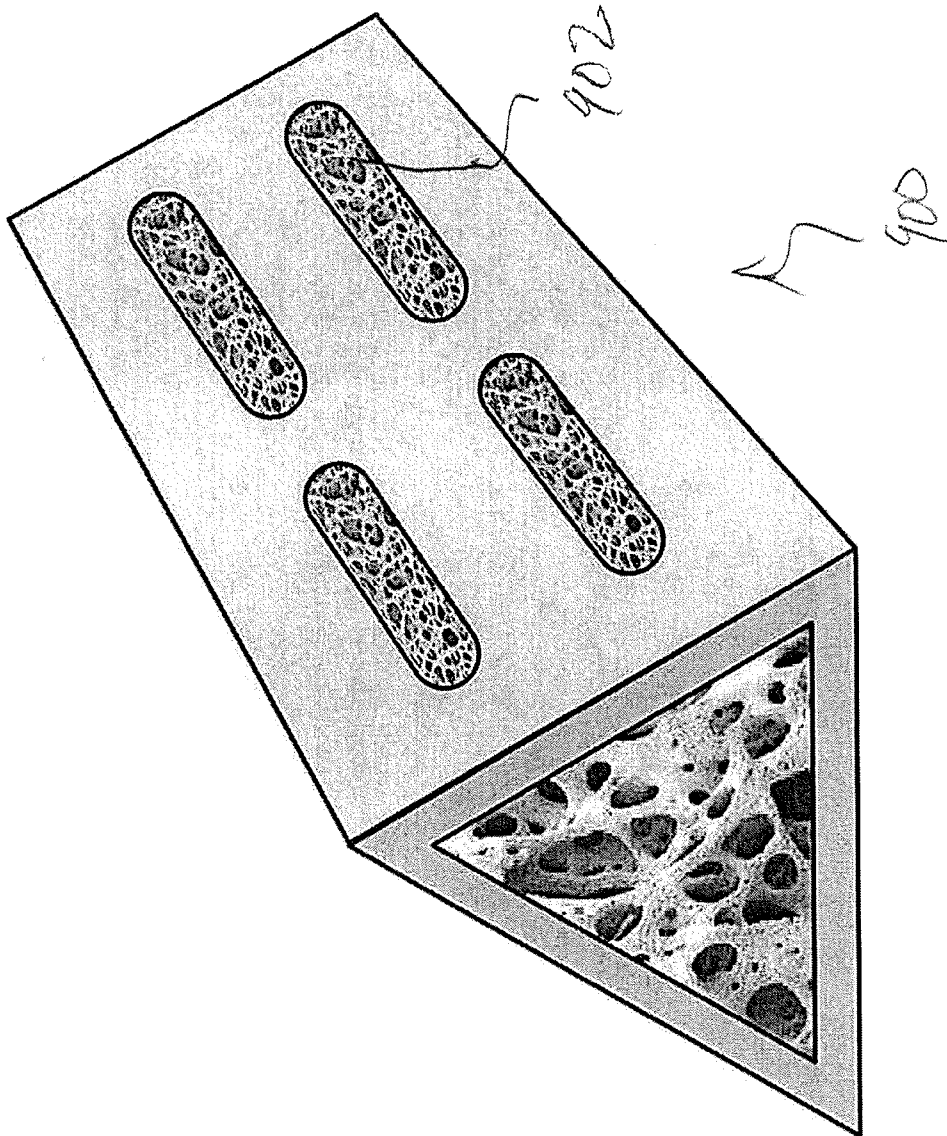

FIG. 9B

**INTERNATIONAL SEARCH REPORT**

International application No.  
PCT/US13/39711

<b>A. CLASSIFICATION OF SUBJECT MATTER</b>				
IPC(8) - A61B 17/04 (2013.01) USPC - 606/301, 300, 60, 53 According to International Patent Classification (IPC) or to both national classification and IPC				
<b>B. FIELDS SEARCHED</b>				
Minimum documentation searched (classification system followed by classification symbols) IPC(8): A61B 17/04 (2013.01) USPC: 606/301, 300, 60, 53				
Documentation searched other than minimum documentation to the extent that such documents are included in the fields searched				
Electronic data base consulted during the international search (name of data base and, where practicable, search terms used) MicroPatent (US-G, US-A, EP-A, EP-B, WO, JP-bib, DE-C,B, DE-A, DE-T, DE-U, GB-A, FR-A); DialogPRO; Google; Google Scholar; Medline/PubMed: bone, femur, tibia, humerus, ulna, patella, fibula, elongated, longitudinal, tubular, rectilinear, linear, straight, unbending, uncurving, faces, multifaceted, apex, apices, lumen, central canal, central channel, fenestrated, holes, fluid, liquid, fluid-filled				
<b>C. DOCUMENTS CONSIDERED TO BE RELEVANT</b>				
Category*	Citation of document, with indication, where appropriate, of the relevant passages	Relevant to claim No.		
Y	US 2011/0087296 A1 (REILEY, MA et al.) April 14, 2011; figures 2, 4, 6, 31, 32, 33; paragraphs, [0033], [0048], [0074], [0075], [0077], [0096]; claim 15	1-8		
Y	US 5593409 A (MICHELSON, GK) January 14, 1997; figures 11, 23, 29-34, 36-38, 41, 42; column 10, lines 6-8, 13-14, 33-39; column 11, line 13; column 13, lines 4-13; column 14, lines 17-20, 51-53; claim 7	1-8		
Y	US 4904261 A (DOVE, J et al.) February 27, 1990; figures 1, 2	8		
<input type="checkbox"/> Further documents are listed in the continuation of Box C. <input type="checkbox"/>				
<table border="0" style="width:100%;"> <tr> <td style="width:50%; vertical-align: top;">                 * Special categories of cited documents:                  "A" document defining the general state of the art which is not considered to be of particular relevance                  "E" earlier application or patent but published on or after the international filing date                  "L" document which may throw doubts on priority claim(s) or which is cited to establish the publication date of another citation or other special reason (as specified)                  "O" document referring to an oral disclosure, use, exhibition or other means                  "P" document published prior to the international filing date but later than the priority date claimed             </td> <td style="width:50%; vertical-align: top;">                 "T" later document published after the international filing date or priority date and not in conflict with the application but cited to understand the principle or theory underlying the invention                  "X" document of particular relevance; the claimed invention cannot be considered novel or cannot be considered to involve an inventive step when the document is taken alone                  "Y" document of particular relevance; the claimed invention cannot be considered to involve an inventive step when the document is combined with one or more other such documents, such combination being obvious to a person skilled in the art                  "&amp;" document member of the same patent family             </td> </tr> </table>			* Special categories of cited documents: "A" document defining the general state of the art which is not considered to be of particular relevance "E" earlier application or patent but published on or after the international filing date "L" document which may throw doubts on priority claim(s) or which is cited to establish the publication date of another citation or other special reason (as specified) "O" document referring to an oral disclosure, use, exhibition or other means "P" document published prior to the international filing date but later than the priority date claimed	"T" later document published after the international filing date or priority date and not in conflict with the application but cited to understand the principle or theory underlying the invention "X" document of particular relevance; the claimed invention cannot be considered novel or cannot be considered to involve an inventive step when the document is taken alone "Y" document of particular relevance; the claimed invention cannot be considered to involve an inventive step when the document is combined with one or more other such documents, such combination being obvious to a person skilled in the art "&" document member of the same patent family
* Special categories of cited documents: "A" document defining the general state of the art which is not considered to be of particular relevance "E" earlier application or patent but published on or after the international filing date "L" document which may throw doubts on priority claim(s) or which is cited to establish the publication date of another citation or other special reason (as specified) "O" document referring to an oral disclosure, use, exhibition or other means "P" document published prior to the international filing date but later than the priority date claimed	"T" later document published after the international filing date or priority date and not in conflict with the application but cited to understand the principle or theory underlying the invention "X" document of particular relevance; the claimed invention cannot be considered novel or cannot be considered to involve an inventive step when the document is taken alone "Y" document of particular relevance; the claimed invention cannot be considered to involve an inventive step when the document is combined with one or more other such documents, such combination being obvious to a person skilled in the art "&" document member of the same patent family			
Date of the actual completion of the international search 24 September 2013 (24.09.2013)		Date of mailing of the international search report <b>27 SEP 2013</b>		
Name and mailing address of the ISA/US Mail Stop PCT, Attn: ISA/US, Commissioner for Patents P.O. Box 1450, Alexandria, Virginia 22313-1450 Facsimile No. 571-273-3201		Authorized officer:  Shane Thomas  PCT Helpdesk: 571-272-4300 PCT OSP: 571-272-7774		

INTERNATIONAL SEARCH REPORT

International application No.

PCT/US13/39711

**Box No. II Observations where certain claims were found unsearchable (Continuation of item 2 of first sheet)**

This international search report has not been established in respect of certain claims under Article 17(2)(a) for the following reasons:

1.  Claims Nos.:  
because they relate to subject matter not required to be searched by this Authority, namely:
  
2.  Claims Nos.:  
because they relate to parts of the international application that do not comply with the prescribed requirements to such an extent that no meaningful international search can be carried out, specifically:
  
3.  Claims Nos.:  
because they are dependent claims and are not drafted in accordance with the second and third sentences of Rule 6.4(a).

**Box No. III Observations where unity of invention is lacking (Continuation of item 3 of first sheet)**

This International Searching Authority found multiple inventions in this international application, as follows:

Group I: Claims 1-8 are directed toward an implant for bone fixation, the implant comprising: an elongate body having a longitudinal axis and a rectilinear cross section transverse to the longitudinal axis, a plurality of faces, a plurality of apices joining the plurality of faces, a central lumen extending along the longitudinal axis of the elongate body, and a plurality of holes with openings on the plurality of faces, wherein the holes are in fluid communication with the central lumen.

Group II: Claims 9-13 are directed toward an implant for bone fixation, the implant comprising: an elongate body having a longitudinal axis and a rectilinear cross section transverse to the longitudinal axis, a plurality of faces, a plurality of apices joining the plurality of faces, a central lumen extending along the longitudinal axis of the elongate body, and a plurality of side pockets extending along a portion of each of the plurality of faces, wherein the side pockets have a depth that does not extend to the central lumen.

\*\*\*See Supplemental Sheet Below\*\*\*

1.  As all required additional search fees were timely paid by the applicant, this international search report covers all searchable claims.
2.  As all searchable claims could be searched without effort justifying additional fees, this Authority did not invite payment of additional fees.
3.  As only some of the required additional search fees were timely paid by the applicant, this international search report covers only those claims for which fees were paid, specifically claims Nos.:
  
4.  No required additional search fees were timely paid by the applicant. Consequently, this international search report is restricted to the invention first mentioned in the claims; it is covered by claims Nos.:  
1-8

**Remark on Protest**

- The additional search fees were accompanied by the applicant's protest and, where applicable, the payment of a protest fee.
- The additional search fees were accompanied by the applicant's protest but the applicable protest fee was not paid within the time limit specified in the invitation.
- No protest accompanied the payment of additional search fees.

## INTERNATIONAL SEARCH REPORT

International application No.

PCT/US13/39711

\*\*\*Continuation of Box No. III - Observations where unity of invention is lacking:\*\*\*

Group III: Claim 14 is directed toward an implant for bone fixation, the implant comprising: an elongate body having a longitudinal axis and a rectilinear cross section transverse to the longitudinal axis, a plurality of faces, a plurality of apèxes joining the plurality of faces, and a central lumen extending along the longitudinal axis of the elongate body, wherein each one of the plurality of apèxes includes a groove that extends along the length of the apex.

Group IV: Claim 15 are directed toward An implant for bone fixation, the implant comprising: an elongate body having a longitudinal axis and a rectilinear cross section transverse to the longitudinal axis, a plurality of faces, a plurality of apèxes joining the plurality of faces, and a central lumen extending along the longitudinal axis of the elongate body, wherein each one of the plurality of apèxes includes a plurality of pockets located at discrete points along the length of each apex.

Group V: Claims 16-27 are directed toward an implant for bone fixation, the implant comprising: an elongate body having a longitudinal axis, a distal end, a proximal end, and a rectilinear cross section transverse to the longitudinal axis, a plurality of faces, each face formed from a wall with a thickness between about 2 to 3 mm in thickness, and a plurality of fenestrations disposed on each face.

The inventions listed as Groups I-V do not relate to a single general inventive concept under PCT Rule 13.1 because, under PCT Rule 13.2, they lack the same or corresponding special technical features for the following reasons: the special technical features of Group I include a plurality of holes with openings on the plurality of faces, wherein the holes are in fluid communication with the central lumen, which are not present in Groups II-V; the special technical features of Group II include a plurality of side pockets extending along a portion of each of the plurality of faces, wherein the side pockets have a depth that does not extend to the central lumen, which are not present in Groups I and III-V; the special technical features of Group III include wherein each one of the plurality of apèxes includes a groove that extends along the length of the apex, which are not present in Groups I-II and IV-V; the special technical features of Group IV include wherein each one of the plurality of apèxes includes a plurality of pockets located at discrete points along the length of each apex, which are not present in Groups I-III and V; the special technical features of Group V include an elongate body having a distal end and a proximal end, each face formed from a wall with a thickness between about 2 to 3 mm in thickness, and a plurality of fenestrations disposed on each face, which are not present in Groups I-IV

The common technical features of Groups I-IV are an implant for bone fixation, the implant comprising: an elongate body having a longitudinal axis and a rectilinear cross section transverse to the longitudinal axis, a plurality of faces, a plurality of apèxes joining the plurality of faces, and a central lumen extending along the longitudinal axis of the elongate body. However, these technical features are disclosed by US 2011/0066190 A1 to Schaller, et al. (hereinafter 'Schaller'). Schaller discloses an implant for bone fixation (device for treating a bone that is coupled to a bone stabilization implant; abstract; claim 1), the implant comprising: an elongate body having a longitudinal axis and a rectilinear cross section transverse to the longitudinal axis device 102 includes elongated body 112 which has a longitudinal axis and a rectilinear cross section transverse to the longitudinal axis; figure 1; paragraph [0013]), a plurality of faces (plate 104 has two (plurality) faces on either side; figure 1; paragraph [0013]), a plurality of apèxes joining the plurality of faces (corners connecting opposing faces of plate 104 serve as apèxes; figure 1), and a central lumen extending along the longitudinal axis of the elongate body (elongated body 112 includes a lumen 118 extending therethrough; figure 1; paragraph [0014]).

Since these common technical features are previously disclosed by the Schaller reference, the common features are not special and so Groups I-IV lack unity.

The common technical features of Groups I-IV and V are an implant for bone fixation, the implant comprising: an elongate body having a longitudinal axis and a rectilinear cross section transverse to the longitudinal axis, a plurality of faces, a plurality of apèxes joining the plurality of faces, and a central lumen extending along the longitudinal axis of the elongate body. However, these technical features are disclosed by US 2011/0066190 A1 to Schaller, et al. (hereinafter 'Schaller'). Schaller discloses an implant for bone fixation (device for treating a bone that is coupled to a bone stabilization implant; abstract; claim 1), the implant comprising: an elongate body having a longitudinal axis and a rectilinear cross section transverse to the longitudinal axis (device 102 includes elongated body 112 which has a longitudinal axis and a rectilinear cross section transverse to the longitudinal axis; figure 1; paragraph [0013]), a plurality of faces (plate 104 has two (plurality) faces on either side; figure 1; paragraph [0013]).

Since these common technical features are previously disclosed by the Schaller reference, the common features are not special and so Groups I-IV and V lack unity.