



(86) **Date de dépôt PCT/PCT Filing Date:** 2015/04/23
 (87) **Date publication PCT/PCT Publication Date:** 2015/12/17
 (85) **Entrée phase nationale/National Entry:** 2016/12/06
 (86) **N° demande PCT/PCT Application No.:** US 2015/027247
 (87) **N° publication PCT/PCT Publication No.:** 2015/191169
 (30) **Priorité/Priority:** 2014/06/12 (US62/011,231)

(51) **Cl.Int./Int.Cl. F01D 25/24** (2006.01),
F01D 11/08 (2006.01), **F01D 9/02** (2006.01)
 (71) **Demandeur/Applicant:**
GENERAL ELECTRIC COMPANY, US
 (72) **Inventeurs/Inventors:**
SHAPIRO, JASON DAVID, US;
SCHILLING, JAN CHRISTOPHER, US;
FRANKS, MICHAEL JOHN, US
 (74) **Agent:** CRAIG WILSON AND COMPANY

(54) **Titre : ENSEMBLE DE SUSPENSION DE CARENAGE**
 (54) **Title: SHROUD HANGER ASSEMBLY**

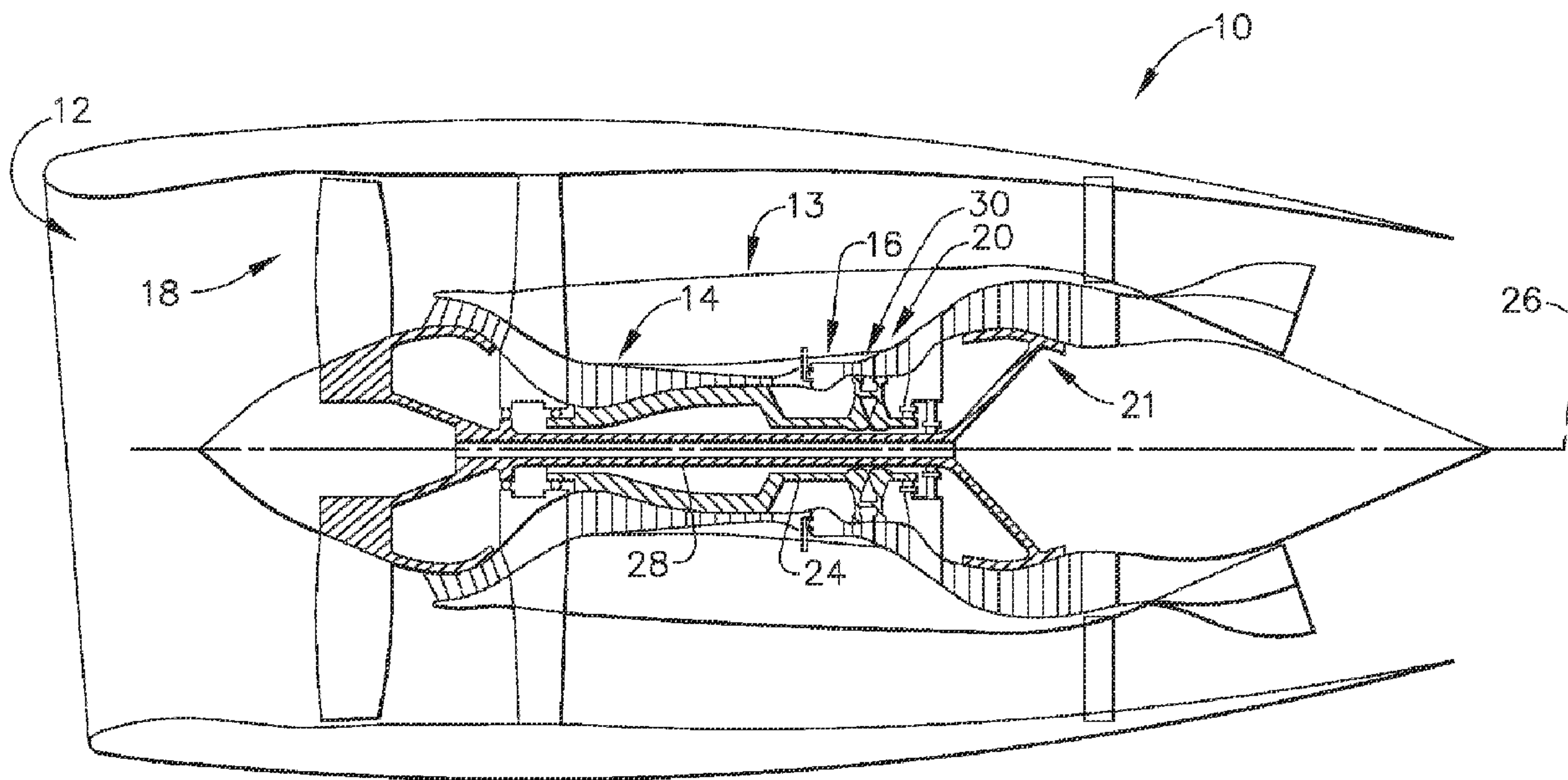

FIG. 1

(57) **Abrégé/Abstract:**

A shroud hanger assembly (30) or shroud assembly is provided for dimensionally incompatible components wherein the assembly includes a multi-piece hanger (32), for example having a forward hanger portion (34) and a rearward hanger portion (36). A cavity (46) is formed between the parts; wherein a shroud (50) may be positioned which is formed of a low coefficient of thermal expansion material. The hanger (32) and shroud (50) may be formed of the same material or differing materials in order to better match the thermal growth between the hanger and the shroud. When the shroud (50) is positioned within the hanger opening or cavity (46), one of the forward (34) and rearward hanger (36) portions may be press fit or otherwise connected into the other of the forward (34) and rearward (36) hanger portion.

(12) INTERNATIONAL APPLICATION PUBLISHED UNDER THE PATENT COOPERATION TREATY (PCT)

CORRECTED VERSION

(19) World Intellectual Property
Organization
International Bureau



WIPO | PCT



(10) International Publication Number
WO 2015/191169 A8

(43) International Publication Date
17 December 2015 (17.12.2015)

(51) International Patent Classification:
F01D 25/24 (2006.01)

(21) International Application Number:
PCT/US2015/027247

(22) International Filing Date:
23 April 2015 (23.04.2015)

(25) Filing Language: English

(26) Publication Language: English

(30) Priority Data:
62/011,231 12 June 2014 (12.06.2014) US

(71) Applicant: **GENERAL ELECTRIC COMPANY**
[US/US]; 1 River Road, Schenectady, NY 12345 (US).

(72) Inventors: **SHAPIRO, Jason, David**; 1000 Western Ave,
Lynn, MA 01910-0002 (US). **SCHILLING, Jan, Chris-**
topher; One Neumann Way, Evendale, OH 45215-1988
(US). **FRANKS, Michael, John**; One Neumann Way, Cin-
cinnati, OH 45215-1988 (US).

(74) Agents: **OVERBECK, Brian, P.** et al.; General Electric
Company, Global Patent Operation, 3135 Easton Turnpike,
Fairfield, CT 06828 (US).

(81) Designated States (*unless otherwise indicated, for every
kind of national protection available*): AE, AG, AL, AM,
AO, AT, AU, AZ, BA, BB, BG, BH, BN, BR, BW, BY,

BZ, CA, CH, CL, CN, CO, CR, CU, CZ, DE, DK, DM,
DO, DZ, EC, EE, EG, ES, FI, GB, GD, GE, GH, GM, GT,
HN, HR, HU, ID, IL, IN, IR, IS, JP, KE, KG, KN, KP, KR,
KZ, LA, LC, LK, LR, LS, LU, LY, MA, MD, ME, MG,
MK, MN, MW, MX, MY, MZ, NA, NG, NI, NO, NZ, OM,
PA, PE, PG, PH, PL, PT, QA, RO, RS, RU, RW, SA, SC,
SD, SE, SG, SK, SL, SM, ST, SV, SY, TH, TJ, TM, TN,
TR, TT, TZ, UA, UG, US, UZ, VC, VN, ZA, ZM, ZW.

(84) Designated States (*unless otherwise indicated, for every
kind of regional protection available*): ARIPO (BW, GH,
GM, KE, LR, LS, MW, MZ, NA, RW, SD, SL, ST, SZ,
TZ, UG, ZM, ZW), Eurasian (AM, AZ, BY, KG, KZ, RU,
TJ, TM), European (AL, AT, BE, BG, CH, CY, CZ, DE,
DK, EE, ES, FI, FR, GB, GR, HR, HU, IE, IS, IT, LT, LU,
LV, MC, MK, MT, NL, NO, PL, PT, RO, RS, SE, SI, SK,
SM, TR), OAPI (BF, BJ, CF, CG, CI, CM, GA, GN, GQ,
GW, KM, ML, MR, NE, SN, TD, TG).

Published:

— with international search report (Art. 21(3))

(48) Date of publication of this corrected version:
24 November 2016

(15) Information about Correction:
see Notice of 24 November 2016

(54) Title: SHROUD HANGER ASSEMBLY

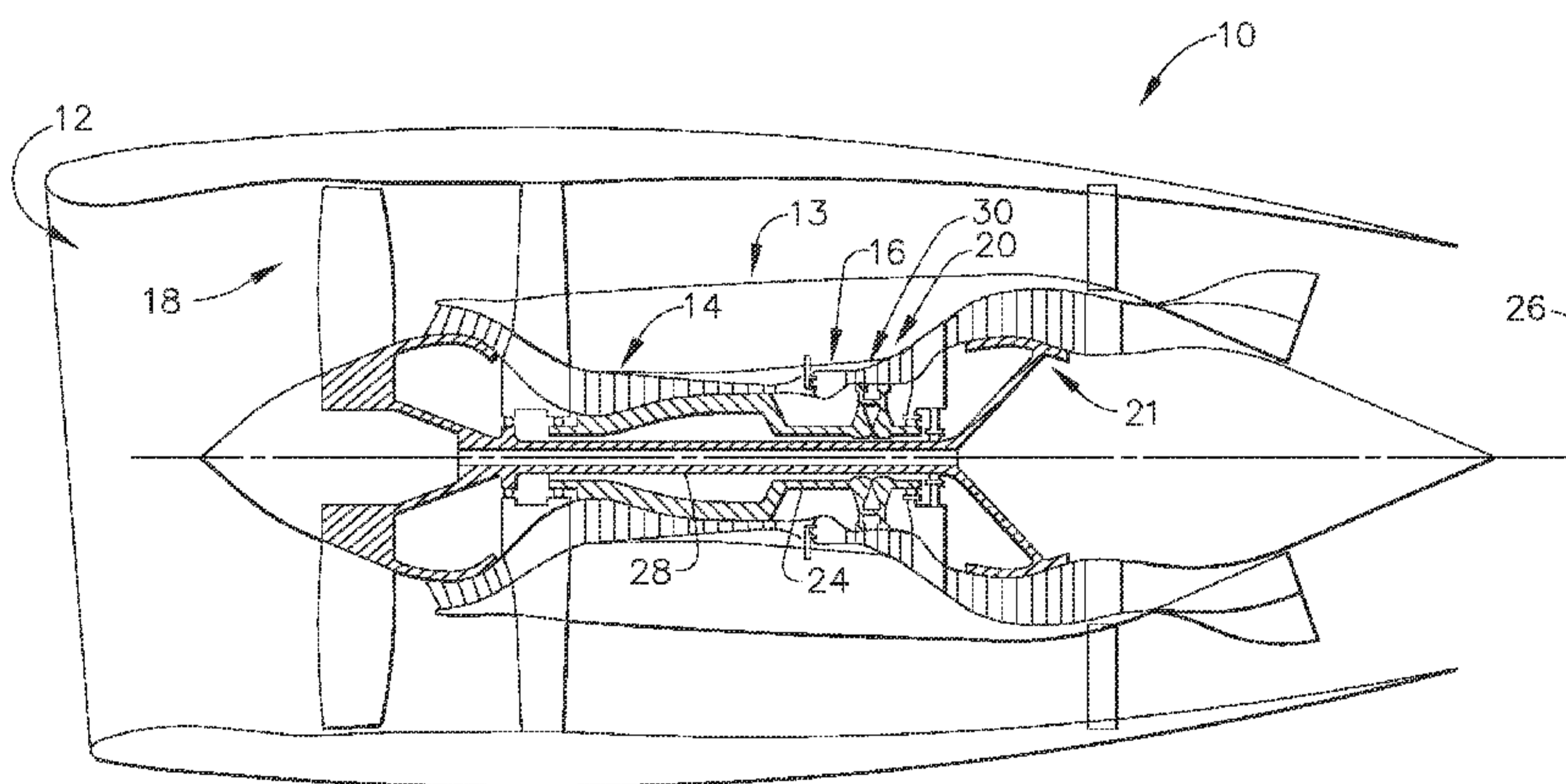

FIG. 1

(57) Abstract: A shroud hanger assembly (30) or shroud assembly is provided for dimensionally incompatible components wherein the assembly includes a multi-piece hanger (32), for example having a forward hanger portion (34) and a rearward hanger portion (36). A cavity (46) is formed between the parts; wherein a shroud (50) may be positioned which is formed of a low coefficient of thermal expansion material. The hanger (32) and shroud (50) may be formed of the same material or differing materials in order to better match the thermal growth between the hanger and the shroud. When the shroud (50) is positioned within the hanger opening or cavity (46), one of the forward (34) and rearward hanger (36) portions may be press fit or otherwise connected into the other of the forward (34) and rearward (36) hanger portion.

SHROUD HANGER ASSEMBLY

STATEMENT REGARDING FEDERALLY SPONSORED RESEARCH

[0001] None.

CROSS-REFERENCE TO RELATED DOCUMENTS

[0002] The present application claims priority to U.S. Provisional Patent Application Serial No. 62/011231 titled "Shroud Hanger Assembly" of Jason David Shapiro, et.al., filed on 12 June 2014, the disclosure of which is incorporated by reference herein.

TECHNICAL FIELD

[0003] The present embodiments relate to a shroud hanger assembly for use in a gas turbine engine. More specifically, present embodiments relate to, without limitation, a shroud hanger assembly including features to improve retaining of a shroud therein.

BACKGROUND

[0004] A gas turbine engine includes a turbomachinery core having a high pressure compressor, combustor, and high pressure turbine ("HPT") in serial flow relationship. The core is operable in a known manner to generate a primary gas flow. The high pressure turbine includes annular arrays ("rows") of stationary vanes or nozzles that direct the gases exiting the combustor into rotating blades or buckets. Collectively one row of nozzles and one row of blades make up a "stage". Typically two or more stages are used in serial flow relationship. These components operate in an extremely high temperature environment, and must be cooled by air flow to ensure adequate service life.

[0005] Due to operating temperatures within the primary flowpath of the gas turbine engine, it is desirable to utilize materials that have high temperature capability and do not require large amounts of cooling air. The higher operating temperatures within the engine improve the engine cycle thermal efficiency if the air used to cool the flowpath parts can be reduced. For example, to operate efficiently in such strenuous temperature and pressure conditions, composite materials have been suggested due to their superior temperature capability over metallic materials. In particular, ceramic matrix composites (CMC) materials are an ideal material for high temperature flowpath

applications. Although CMC materials have higher temperature capability, they have a lower coefficient of thermal expansion than the metallic alloys which are used to support the CMC components and create sealing surfaces to the CMC components. Sealing is extremely important in order to retain the advantage that CMC materials have of reduced cooling air.

[0006] One desirable use for the higher temperature material (CMC) is a turbine shroud. However, various problems are known to exist with the supporting metallic hardware (shroud hanger). For example, some assemblies utilize a one-piece hanger construction that is deflected apart during the insertion of the shroud into a cavity of the shroud hanger. This interference at assembly is required to maintain sealing throughout the engine cycle and, is due to the difference in coefficient of expansion of the metallic hanger and the CMC shroud. However, this mechanical deflection may cause bending or even yielding of the hanger arms during positioning of the shroud which is undesirable and may cause premature deformation and leakage at high temperature. Therefore, it would be desirable to have an assembly which is more easily assembled and will not cause yielding of the hanger.

[0007] It would be desirable to overcome the thermal differences and provide a hanger and shroud which is more easily assembled. It would also be desirable to reduce hanger and shroud stress caused by the thermal differences while maintaining sealing between the two parts; therefore it is also further desirable to better thermally match the metallic support to the composite shroud.

[0008] The information included in this Background section of the specification, including any references cited herein and any description or discussion thereof, is included for technical reference purposes only and is not to be regarded subject matter by which the scope of the invention is to be bound.

SUMMARY

[0009] A shroud hanger assembly or shroud assembly is provided for dimensionally incompatible components such as those which are press or frictionally fit to engage one another. The assembly includes a multi-piece hanger, for example having a forward hanger portion and a rearward hanger portion. A cavity is formed between the parts wherein a shroud may be positioned which is formed of a low coefficient of thermal expansion material. The hanger and shroud may be formed of the same material or differing materials in order to better match the thermal growth

between the hanger and the shroud. When the shroud is positioned within the hanger opening or cavity, one of the forward and rearward hanger portions may be press fit or otherwise connected into the other of the forward and rearward hanger portion.

[0010] According to some embodiments, a shroud hanger assembly for dimensionally incompatible components comprises a multi-piece shroud hanger formed of a first material, the shroud hanger having a forward hanger portion and a rearward hanger portion. A shroud may be formed of a low coefficient of thermal expansion second material, the shroud disposed between the forward hanger portion and the rearward hanger portion, wherein at least one of the forward hanger portion and the rearward hanger portion apply an axial interference force on the shroud.

[0011] This Summary is provided to introduce a selection of concepts in a simplified form that are further described below in the Detailed Description. This Summary is not intended to identify key features or essential features of the claimed subject matter, nor is it intended to be used to limit the scope of the claimed subject matter. All of the above outlined features are to be understood as exemplary only and many more features and objectives of the structures and methods may be gleaned from the disclosure herein. A more extensive presentation of features, details, utilities, and advantages of the present invention is provided in the following written description of various embodiments of the invention, illustrated in the accompanying drawings, and defined in the appended claims. Therefore, no limiting interpretation of the summary is to be understood without further reading of the entire specification, claims and drawings included herewith.

BRIEF DESCRIPTION OF THE ILLUSTRATIONS

[0012] The above-mentioned and other features and advantages of these embodiments, and the manner of attaining them, will become more apparent and the embodiments will be better understood by reference to the following description taken in conjunction with the accompanying drawings, wherein:

[0013] FIG. 1 side section view of an exemplary gas turbine engine;

[0014] FIG. 2 is an end section view of an exemplary shroud hanger assembly;

[0015] FIG. 3 is a lower perspective view of a multi-piece hanger;

[0016] FIG. 4 is a lower perspective view of an exemplary multi-piece hanger from an alternate angle;

- [0017] FIG. 5 is an exploded perspective view of the exemplary shroud hanger assembly;
- [0018] FIG. 6 is a perspective view of an alternate embodiment of a shroud hanger assembly;
- [0019] FIG. 7 is an exploded perspective view of the assembly of FIG. 6;
- [0020] FIG. 8 is a side section view of a further embodiment of a multi-piece hanger; and,
- [0021] FIG. 9 is a side section view of still a further embodiment of a multi-piece hanger.

DETAILED DESCRIPTION

[0022] It is to be understood that the depicted embodiments are not limited in application to the details of construction and the arrangement of components set forth in the following description or illustrated in the drawings. The depicted embodiments are capable of other embodiments and of being practiced or of being carried out in various ways. Each example is provided by way of explanation, not limitation of the disclosed embodiments. In fact, it will be apparent to those skilled in the art that various modifications and variations may be made in the present embodiments without departing from the scope or spirit of the disclosure. For instance, features illustrated or described as part of one embodiment may be used with another embodiment to still yield further embodiments. Thus it is intended that

the present disclosure covers such modifications and variations as come within the scope of the appended claims and their equivalents.

[0023] Embodiments of a shroud hanger assembly are depicted in FIGS. 1-9. The hanger assembly includes a one-piece or multi-piece hanger including at least two legs which are formed of a first material. A shroud is positioned within a shroud hanger cavity and the multi-piece hanger may be constructed more easily due to the joiner of the first and second portions in the axial direction to provide an axial interference force on the shroud. The hanger may include at least one cooling cavity in order to inhibit thermal growth of the hanger and maintain clamping force on the shroud.

[0024] Also, it is to be understood that the phraseology and terminology used herein is for the purpose of description and should not be regarded as limiting. The use of “including,” “comprising,” or “having” and variations thereof herein is meant to encompass the items listed thereafter and equivalents thereof as well as additional items. Unless limited otherwise, the terms “connected,” “coupled,” and “mounted,” and variations thereof herein are used broadly and

“connected” and “coupled” and variations thereof are not restricted to physical or mechanical connections or couplings.

[0025] As used herein, the terms “axial” or “axially” refer to a dimension along a longitudinal axis of an engine. The term “forward” used in conjunction with “axial” or “axially” refers to moving in a direction toward the engine inlet, or a component being relatively closer to the engine inlet as compared to another component. The term “aft” used in conjunction with “axial” or “axially” refers to moving in a direction toward the engine nozzle, or a component being relatively closer to the engine nozzle as compared to another component.

[0026] As used herein, the terms “radial” or “radially” refer to a dimension extending between a center longitudinal axis of the engine and an outer engine circumference. The use of the terms “proximal” or “proximally,” either by themselves or in conjunction with the terms “radial” or “radially,” refers to moving in a direction toward the center longitudinal axis, or a component being relatively closer to the center longitudinal axis as compared to another component. The use of the terms “distal” or “distally,” either by themselves or in conjunction with the terms “radial” or “radially,” refers to moving in a direction toward the

outer engine circumference, or a component being relatively closer to the outer engine circumference as compared to another component.

[0027] As used herein, the terms “lateral” or “laterally” refer to a dimension that is perpendicular to both the axial and radial dimensions.

[0028] All directional references (e.g., radial, axial, proximal, distal, upper, lower, upward, downward, left, right, lateral, front, back, top, bottom, above, below, vertical, horizontal, clockwise, counterclockwise) are only used for identification purposes to aid the reader’s understanding of the present invention, and do not create limitations, particularly as to the position, orientation, or use of the invention. Connection references (e.g., attached, coupled, connected, and joined) are to be construed broadly and may include intermediate members between a collection of elements and relative movement between elements unless otherwise indicated. As such, connection references do not necessarily infer that two elements are directly connected and in fixed relation to each other. The exemplary drawings are for purposes of illustration only and the dimensions, positions, order and relative sizes reflected in the drawings attached hereto may vary.

[0029] Referring initially to FIG. 1, a schematic side section view of a gas turbine engine 10 is shown. The function of the turbine is to extract energy from high pressure and

temperature combustion gases and convert the energy into mechanical energy for work. The gas turbine engine 10 has an engine inlet end 12 wherein air enters the core or propulsor 13 which is defined generally by a compressor 14, a combustor 16 and a multi-stage high pressure turbine 20 all located along an engine axis 26. Collectively, the propulsor 13 provides power during operation. The propulsor 13 may be used for aviation, power generation, industrial, marine or the like.

[0030] In operation, air enters through the air inlet end 12 of the engine 10 and moves through at least one stage of compression where the air pressure is increased and directed to the combustor 16. The compressed air is mixed with fuel and burned providing the hot combustion gas which exits the combustor 16 toward the high pressure turbine 20. At the high pressure turbine 20, energy is extracted from the hot combustion gas causing rotation of turbine blades which in turn cause rotation of the shaft 24. The shaft 24 passes toward the front of the engine to continue rotation of the one or more compressor stages 14, a turbofan 18 or inlet fan blades, depending on the turbine design. The turbofan 18 is connected by the

shaft 28 to a low pressure turbine 21 and creates thrust for the turbine engine 10. The low pressure turbine 21 may also be utilized to extract further energy and power additional compressor stages.

[0031] A shroud hanger assembly 30 may be utilized to define a flow path adjacent to rotating parts such as turbine blades 22 (FIG. 2) of turbine 20, 21. The shroud hanger assembly 30 is shown schematically in the schematic FIG. 1 view. The assembly 30 may be disposed at a radially outward stationary end of the turbine 20, 21 above the rotating turbine blades 22 or the blades of the compressor 14.

[0032] Referring now to FIG. 2, an end section view of an exemplary shroud hanger assembly 30 is depicted and depending from an engine casing. The assembly 30 involves dimensionally incompatible components. The phrase “dimensionally incompatible” refers to components which may have an interference fit with one another and which may have thermal growth rates of differing amounts or coefficients of differing values. The assembly 30 includes a multi-piece hanger 32 having a first portion 34 and a second portion 36 which define the hanger 32. The hanger 32 includes first and second tabs 38, 40 which are utilized to connect the assembly 30 to an engine casing. The hanger 32 extends circumferentially about the engine axis 26 such that a plurality of segments are positioned together to define an entire circumferential assembly about the engine. Extending between the first tab and the second tab 38, 40 is a hanger ceiling or web 42 which extends between the first hanger portion 34 and the second or rearward hanger portion 36. The hanger ceiling 42 may be linear, curvilinear or may be defined by more than one linear segment. Depending from the tabs 38, 40 are legs 39, 37. The legs 39, 37 may or may not define parts of the first portion 34 and the second portion 36. The first tab 38 and leg 39 extend above a chordal groove 44 which extends from one circumferential end of the hanger 32 to the opposite end. The groove 44 allows for the first portion 34 to be press fit into the second portion 36.

[0033] The shroud hanger 32 may be formed of a metallic material with a relatively high coefficient of thermal expansion as compared to the shroud 50. Alternatively, the hanger 32 may be formed of a relatively low coefficient of thermal expansion material.

[0034] Beneath the ceiling 42 and the first portion 34 and the aft second portion 36, is a cavity 46 wherein a shroud 50 is positioned. The shroud 50 may be formed of a low coefficient of

50 may be of various types including closed top and open top and may further comprise an impingement baffle 52 positioned within the shroud and in flow communication with cooling apertures or channels extending through the hanger 32 to cool the shroud 50. One or more cooling apertures or channels 33 (FIG. 3) may extend through either or both of the first hanger portion 34 and the second hanger portion 36 to provide flow communication to the impingement baffle 52 for cooling of shroud 50. According to the exemplary embodiments, the cooling apertures 33 may extend through the first hanger portion 34 into a cavity between the first and second hanger portions 34, 36. However, the apertures may alternatively extend through the leg 39 of the second portion 36.

[0035] Referring now to FIG. 3, a lower perspective view of the hanger 32 is depicted with the shroud 50 removed to reveal interior portions of the hanger 32. The hanger 32 depicted is a two-piece structure however, multi-piece structures may be used with additional portions. The forward portion 34 includes a chordal interface rib 43. The rib 43 extends into a chordal groove 44. The interface between the hanger second portion 36 and the first portion 34 is chordal in order to improve bending stresses within the interface of the parts 34, 36 improving clamping force between first and second portions 34, 36 when thermal growth occurs. According to the instant embodiments, the second hanger portion 36 is the main body of the hanger 32 and the first hanger portion 34 which is cantilevered from the second portion 36. The first portion 34 applies an axial force to capture the shroud 50 within the cavity 46 of the hanger 32. However, according to alternate embodiments, the main body of the hanger 32 that is the larger portion may be defined by a forward portion and the opposite second portion may define a cantilevered leg or smaller portion of the hanger as a whole.

[0036] The first hanger portion 34 includes the interface rib 43 and a spring leg 45. The rib 43 extends chordally rather than circumferentially. The spring leg 45 has a forward surface and an aft surface and includes a chordal interference rib 47 on the aft side of the spring leg 45. The chordal interference rib 47 provides an engagement surface for engagement with the shroud 50. Further, one or more ribs 49 may be located on the forward side of the leg 45 to provide engagement surfaces or grinding surfaces so as to adjust the forward-aft dimension, location and force applied to the shroud 50.

[0037] It should be understood that while in some circumstances the chordal ribs and /or grooves may be utilized, in other circumstances it may be desirable to utilize circumferential ribs and grooves for sealing or some other geometry which may or may not include some combination of the circumferential and chordal designs.

[0038] The leg 45 functions as a spring to provide an axial force on the shroud 50. The shroud 50 may be slightly larger than the cavity between first and second hanger portions 34, 36. Thus, due to this oversizing or dimensional incompatibility, when the first hanger portion 34 is installed with shroud 50 in position, a force is applied on the leg 45 which applies a reactionary axial retaining force on the shroud 50. The chordal interface 43 allows for axial movement of the portion 34, to install the portion 34 into the portion 36 and apply the retaining force, rather than bending and possibly yielding the hanger 32.

[0039] During operation of the engine 10, the shroud 50 and hanger 32 may thermally expand. In light of the interference fit between shroud 50 and the hanger leg 39 (FIG. 2), when the second portion 36 grows an amount in the axial direction, and due to the differing coefficients of thermal growth causing growth at differing rate than shroud 50, some axial clamping force on the shroud 50 may be reduced. The instant embodiment however, improves or maintains a more consistent clamping force on the shroud 50. Additionally, the chordal groove 44 and rib 43 extend linearly rather than arcuately to provide such improved function at operating temperature. Moreover, as described further, the hanger 32 may have one or more cooling cavities 35 to limit axial growth and thereby maintain axial clamping force on the shroud 50. Accordingly, the assembly 30 provides a means of controlling axial growth or alternatively stated, matching axial growth of shroud 50 so that clamping force is maintained at desirable levels.

[0040] The second hanger portion 36 includes an aft wall 37 and slash face wall 41 which extend from the aft end of the hanger 32 to the forward end for engagement with the first hanger portion 34. Within the aft wall 37 is at least one cooling pocket or cavity 35 to provide cooling air into the hanger 32. Local cavities or pockets 35 allow the cooler second stage air to lower the hanger bulk temperature and reduce axial growth mismatch with the shroud 50. The cavities 35 extend into the shroud cavity 46 area but do not allow flow communication therebetween. Instead, these cooling cavities 35 merely provide cooling air toward the interior of the hanger without allowing passthrough of the cooling air to the shroud 50. The cavities cool the under surface of

[0041] The view also depicts a cooling channel 33 which is in fluid communication with cooling air on the forward outside of the hanger 32 and which provides air to an impingement baffle 52 (FIG. 2) for cooling the shroud 50. The cooling channel 33 is shown in FIG. 4 as well, as extending through first portion 34. The cooling channel 33 may be located at various locations of the hanger 32 and although it's shown in one centered location, the channel 33 may be located at various locations in the circumferential direction of the assembly 30 corresponding to flow paths in communication with the impingement baffle 52. The end wall or slash face wall 41 may include one or more slots for receiving slash face seals (not shown) so that air leakage between adjacent hangers 32 may be limited.

[0042] While two cavities 35 are shown in the second hanger portion 36, various numbers of cavities may be used or a single cavity may be used and the lengths may vary in order to tune the desired amount of cooling.

[0043] Referring now to FIG. 4, a lower perspective view of the hanger 32 is shown from a different angle than FIG. 3 so as to reveal the forward surface of the second hanger portion 36. Similar to the first spring leg 45, the second leg 37, which also defines an aft wall, has a forward surface including a chordal interference rib 53. Extending from the second leg 37 toward the forward portion of the second hanger portion 36 and near the interface with the first hanger portion 34, is a boss 48 which allows for positioning of a bolt or fastener to retain the shroud and/or baffle 50, 52.

[0044] When the shroud 50 is inserted into the cavity 46, the first hanger portion 34 functions as a spring and is flexed outwardly to accommodate positioning of the shroud 50 between the first and second portions 34, 36. According to the exemplary embodiment for assembly 30, the forward hanger portion 34 is press fit into the second hanger portion 36 by pressing the interference rib 43 into the chordal groove 44. The forward hanger portion 34 acts as a conformal spring as previously discussed to clamp the shroud 50 providing an axial force against the shroud 50 and retaining the shroud 50 between the first portion 34 and second portion 36. The press fit between the first portion 34 and the second portion 36 provides sealing along the forward and aft faces of the shroud hanger 32 and more uniform contact in clamp force, that is axial force, between the parts.

[0045] The aft wall 37 may further comprise a flange 55 which may support an aft stage nozzle. In operation, the nozzle load 59 may be transferred into the first hanger portion 34 through the shroud 50 and into the aft or second hanger portion 36 then onto the turbine engine case. This is represented by arrow 59 in FIGS. 2 and 4. The flange 55 may be aligned in an axial direction with an interface rib 53 or may be offset some radial distance. Similar to rib 47, the rib 53 is chordal and engages shroud 50 when assembled.

[0046] Referring now to FIG. 5, an exploded perspective view of the shroud hanger assembly 30 is depicted. In the embodiment shown, the first hanger portion 34 is exploded from the second hanger portion 36. The first portion 34 includes the interface rib 43 which is shown removed from the interface groove 44 of the second hanger portion 36. The rib 43 is chordal as shown so as to engage a chordally extending groove 44 in the first portion 34 and beneath the tab 38. The embodiment functions such that when the rib 43 is inserted in an axial direction into the groove 44 and when the shroud 50 (FIG. 2) is inserted into the cavity 46, the spacing of the interference rib 47 from the rib 43 causes engagement of the shroud or moment or cantilever bending of the first portion 34 from the second portion 36.

The second portion 36 is also shown, and the hanger 32 is formed by the first portion 34 and second portion 36 which are joined in either a chordal or circumferential cut.

[0047] The second hanger portion 36 may also have the boss or projection 48 which is depending from the web 42. The projection 48 is depicted centrally in the circumferential direction of the second hanger portion 36. However, the projection 48 may be moved in circumferential directions or alternatively, two or more projections 48 may be utilized for flow communication with the baffle 52.

[0048] The second hanger portion 36 includes an aft wall 37 having at least one cooling cavity 35. In the depicted embodiment, there are two cooling apertures 35. These are generally rectangular in shape, wherein the long walls of the cooling cavity 35 are generally circumferential and matching the circumferential bend of the second portion 36 between the end walls 41. Alternatively, these one or more cooling cavities 35 may be other polygonal shapes and may or may not include curved corners as depicted, and which provide improved air flow characteristics into the pocket. One or more of these projections 48 may include the cooling aperture 33 for flow

[0049] Additionally shown beneath the cavity 46, is the impingement baffle 52. The baffle 52 is in flow communication with the cooling aperture 33. The baffle 52 defines a flow volume with a plurality of cooling holes 54 on a lower surface 57 thereof. The cooling air enters the baffle 52 from the cooling aperture 33 above and is dispensed through the volume so that the air exits the plurality of cooling holes 54 along the bottom of the baffle surface 57. The plurality of baffle apertures 54 provide cooling air to the shroud 50 (FIG. 2) depicted in the assembled view.

[0050] Referring now to FIG. 6, a perspective view of an alternative shroud hanger assembly 130 is depicted. The shroud hanger 132 allows for use of dimensionally incompatible components which may utilize clamping, interference or friction force in order to retain position desired relative to one another. The shroud hanger 132 includes a first leg 145 and a second leg 137 as in the previous embodiment, as well as a ceiling or web 142 extending therebetween. The hanger 132 differs from the previously described embodiments as the instant shroud hanger 132 is formed of a single structure rather than multiple portions. The first leg 145 is depicted as a forward leg relative to the air flow through the engine and the second leg 137 is an aft leg which is positioned downstream relative to the air flow of the first leg 145. The shroud hanger 132 may be formed of a single circumferential structure which extends about the axis of the engine or alternatively, may be formed of multiple segments as depicted in the exemplary embodiment. A slash face or end wall 141 may be located at circumferential ends of the hanger 132.

[0051] The shroud hanger 132 may be formed of a first material which may be metallic or may be some material having a low coefficient of thermal expansion. Such materials include, but are not limited to, ceramic matrix composite, which has desirable characteristics. The hanger 132 includes a cooling channel 133 to direct cooling air flow to a baffle 52 (FIG. 5) for cooling a shroud.

[0052] Also shown at the aft end of the shroud hanger assembly 130, is at least one cooling cavity 135 extending into the second leg 137 of the shroud hanger 132. The cooling cavity 135 allows access of cooling air into the hanger in order to limit thermal growth of the shroud hanger 132. Thus, by limiting or reducing the thermal growth, the hanger may be more closely matched or the growth limited in order to maintain the clamping force on a shroud located therein. While the instant embodiment depicts a single cooling cavity 135,

two or more cavities may be utilized. Additionally, according to this or other embodiments, the cavities may have a plurality of shapes which are circumferential, chordal or otherwise shaped, such as polygonal or curvilinear.

[0053] Referring now to FIG. 7, an exploded perspective view of the alternate embodiment hanger assembly 130 is depicted. The hanger 132 is a one-piece hanger rather than a multi-piece hanger as with the earlier embodiments. In the instant embodiment, the cooling cavity 135 is formed of a single, generally rectangular shaped opening with circumferentially extending sidewalls for the long opening of the rectangular shape. Additionally, at the corners, the substantially rectangular shaped cooling cavity 135 has curved rather than sharp edges. This may improve cooling flow into or out of the cooling cavity 135. While a single opening is shown defining the cooling cavity 135, it is within the scope of the present disclosure that the cavity 135 be formed of two or more openings which may vary in shape. The openings may be rectangular, square shaped, polygonal or have linear or curvilinear walls. Alternatively or additionally, walls may be chordal or circumferential. These polygon shaped cooling cavities may additionally have curved corners to aid in air flow and manufacturing of the part. In other embodiments, the at least one cooling cavity may be curvilinear and not a specific polygonal shape. Additionally, the depicted at least one cooling cavity 135 may extend in a purely axial direction into the shroud hanger 132 or may extend at an angle to the axial direction. Additionally, the cavity 135 may extend in a combination of axial and non-axial directions so that the cavity 135 is not purely linear in extending into the shroud hanger 132. In short, various alternatives are well within the scope of these embodiments and the depicted cooling cavity 135 should not be considered limiting.

[0054] The cooling cavity 135 as previously described limits the amount of growth of the hanger 132 in the axial direction and therefore, improves retaining of the shroud (not shown) within the cavity 146 of the hanger 132.

[0055] Additionally, an impingement baffle 152 is depicted which directs or guides air flow from an at least one cooling channel 133 extending through the shroud hanger 132 to provide impingement flow to the shroud. The depicted baffle 152 includes a plurality of holes 154 along a lower surface and the baffle 152 is in flow communication with at least one cooling aperture 133

through the baffle 152 and passes through the holes 154 to cool a shroud which surrounds the baffle 152.

[0056] The shroud (not shown) is held in place within the cavity 146 by interference rib 147. As with the previous embodiments, the shroud (not shown) may be formed of a second material. The second material may be a low coefficient of thermal expansion material which is the same or different from the material used to form the shroud hanger. The shroud provides an inner flow path surface for the rotor and adjacent turbine blade 22 (FIG. 2) of turbine 20, 21. The shroud may be an opened top or U-shaped shroud or alternatively, may be a closed top shroud as will be understood by one of ordinary skill in the art. In this embodiment, the cooling cavity 135 more accurately controls the axial growth of the hanger 132 and therefore, provides a more controlled clamping force on a shroud despite the difference in materials and/or the difference of coefficient of thermal expansion.

[0057] The at least one cooling cavity 135 may be located along the aft leg of the shroud hanger 132. Alternatively, the at least one cooling cavity 135 may be formed of two or more cavities. The cavities may be formed of various shapes which have sides that are chordal or arcuate in shape. In the exemplary embodiment, at least one cavity is shown as a polygon shaped, specifically rectangular with curved corners but other shapes may be utilized.

[0058] Referring now to FIG. 8, an additional embodiment of a hanger assembly is provided for purpose depicting additional configurations for multi-piece hanger assemblies 230. The hanger assembly 230 is shown in a side-section view. The hanger assembly 230 includes a hanger 232 formed of a first portion 234 and a second portion 236. The first portion 234 and second portion 236 are split along line 235. The split line extends circumferentially and may be centered or off center in the axial direction. The first portion 234 may be at the forward end and the second portion 236 may be at the aft end of the hanger 232. These hanger portions 234, 236 may be connected in axial directions or alternatively, in radial directions so that one of the first and second hanger portions 234, 236 is captured by the second of the first and second hanger portions 234, 236. Additionally, the engine casing may be utilized to capture one or both of the hanger portions 234, 236 in order to aid in building the assembly 230. Either or both of the first and second hanger portions 234, 236 may include one or more tabs 238, 240 for connecting the hanger 232 to the engine casing. A variety of arrangements may be utilized to define the multi-

exemplary embodiment is merely one such embodiment which may be utilized in combination with additional embodiments shown herein. Accordingly, the exemplary hanger 232 should not be considered limiting as other forms of multi-piece hangers may be substituted and are to be considered within the scope of the instant disclosure. For example, according to some embodiments, the hanger 232 may be split 235 centrally or off-center and may split apart in axial directions or in radial directions.

[0059] Depending from the tabs 238, 240 are legs 239, 241. The legs 239, 241 may depend radially at an angle to a radial direction or some combination. A web 242 is depicted extending between the first leg 239 and the second leg 241. The web, first leg and second leg 242, 239, 241 may all be formed of both of the first and second hanger portions 234, 236 or alternatively, may be formed of either of the first portion 234 or second portion 236. The web 242 may extend in an axial direction or alternatively, may be angled from the forward leg 239 to the aft leg 241 or some combination depending on the circumferential location along the web 242. Thus, this configuration may vary within a single part depending on where the section of the part is taken. Between these legs 239, 241 is a cavity 246 wherein a shroud 250 may be positioned. The shroud 250 may be formed of a low coefficient of thermal expansion material which differs from that of the hanger 232. According to some exemplary embodiments, the hanger 232 may be formed of a metallic material such as an alloy which has a relatively higher coefficient of thermal expansion than the material of the shroud 250 which has a relatively lower coefficient of thermal expansion. For example, the shroud 250 may be formed of ceramic matrix composite material (CMC) but is not limited to such embodiment. Accordingly, during operation, the hanger 232 will grow at a thermal rate which is greater than that of the shroud 250. The shroud 250 may take various forms according to the embodiments described herein. For example, the shroud 250 may be a closed top shroud as depicted, meaning the upper portion of the shroud is generally closed. Such closed top may be horizontal, angled, a combination, curvilinear or other forms to substantially close the shroud 250. Alternatively, the shroud 250 may comprise an open top shroud which may be generally u-shaped according to other embodiments or other such shapes in which the top of the shroud is open rather than closed. Within the shroud 250 may be a baffle or insert 252 which cools a surface of the shroud 250. The baffle or insert 252 may be in flow communication with one or more cooling apertures or

to provide cooling over to the shroud 250. The baffle or insert 252 spreads the air in axial and circumferential directions to provide this cooling.

[0060] Referring again to the hanger 232, the present embodiment utilizes a bolt 274 which extends axially through the first hanger portion 234 and the second hanger portion 236. The axial bolt 274 may extend through one or more aligned sleeve 275 in the first and second hanger portions in order to retain the alignment of the first and second hanger portions 234, 236. The sleeves 275 may be of same or differing diameters. According to the instant embodiment, the bolt 274 may extend from the forward to the aft direction. However, according to alternate embodiments, the bolt 274 may extend in an opposite aft to forward direction.

[0061] Referring now to FIG. 9, such alternate embodiment of the shroud hanger assembly 330 is depicted in side-section view. The hanger 332 includes a first hanger portion 334 and a second hanger portion 336 wherein the heights of legs 339, 341 defining these structures may be equal or differ. According to the exemplary embodiment, the first tab 338 is at a higher position than the second tab 340 but this is merely exemplary and may be reversed such that the aft tab 340 is higher than the forward tab 338. The web 342 extends between the first leg 339 and the second leg 341 defining a location where shroud 350 may be positioned. A bolt 374 extends from an aft direction toward the forward direction, opposite the previous embodiment. The bolt 374 may define a locating structure for connection of the hanger portions 334, 336.

[0062] The foregoing description of several embodiments of the invention has been presented for purposes of illustration. It is not intended to be exhaustive or to limit the invention to the precise steps and/or forms disclosed, and obviously many modifications and variations are possible in light of the above teaching. It is intended that the scope of the invention and all equivalents be defined by the claims appended hereto.

CLAIMS

What is claimed is:

1. A shroud hanger assembly (30) for dimensionally incompatible components, comprising:
 - a multi-piece shroud hanger (32) formed of a first material, said shroud hanger (32) having a forward hanger portion (34) and a rearward hanger portion (36);
 - a shroud (50) formed of a low coefficient of thermal expansion second material, said shroud disposed between said forward hanger portion (34) and said rearward hanger portion (36);
 - wherein at least one of said forward hanger portion (34) and said rearward hanger portion (36) apply an axial interference force on said shroud (50).
2. The shroud hanger assembly (30) of Claim 1, said multi-piece shroud hanger (32) being a bolted connection at least in part.
3. The shroud hanger assembly (30) of Claim 1, said multi-piece shroud hanger (32) being a cantilevered connection.
4. The shroud hanger assembly (30) of Claim 1, said rearward hanger portion (36) having cooling cavities (35) extending into said rearward hanger portion (36).
5. The shroud hanger assembly (30) of Claim 1 further comprising a chordal interference rib (47) on at least one of said forward hanger portion (34) and said rearward hanger portion (36) for engagement with the other of said forward hanger portion (34) and said rearward hanger portion (36).
6. The shroud of hanger assembly of Claim 1, further comprising a circumferential shroud rib (43) disposed on one of said shroud (50) and said shroud hanger for engaging said shroud (50) with said shroud hanger assembly (30).
7. The shroud hanger assembly (30) of Claim 1 further comprising at least one cooling channel (33) extending through one of said forward hanger portions (34) and said rearward hanger portions (36) of said shroud hanger assembly (30) for impingement cooling of said shroud.
8. The shroud hanger assembly (30) of Claim 8 further comprising a baffle (52) in flow communication with said at least one cooling channel (33).
9. The shroud hanger assembly (30) of Claim 1, one of said forward hanger portion (34) and said rearward hanger portion (36) being larger than the other of said forward hanger portion (34) and said rearward hanger portion (36).
10. The shroud hanger assembly (30) of Claim 1, further comprising slash face walls (41) which increase stiffness of said rearward hanger portion (36).

11. The shroud hanger assembly (30) of Claim 1, said forward hanger portion (34) being cantilever connected to said rearward hanger portion (36).
12. The shroud hanger assembly (30) of Claim 1, said forward (34) and rearward hanger portions (36) applying said axial force to said shroud (50).
13. The shroud hanger assembly (30) of Claim 1, said shroud (50) having a u-shaped cross-section.
14. The shroud hanger assembly (30) of Claim 1, said shroud (50) having a closed cross-section.
15. A shroud hanger assembly (30) for dimensionally incompatible components, comprising:
 - a shroud hanger (32) formed of a first material, said shroud hanger (32) having a first leg (145), a second leg (137) and a web (142) extending between said first leg (145) and said second leg (137);
 - a shroud (50) formed of a low coefficient of thermal expansion second material;
 - at least one cooling cavity (33) located in said shroud hanger (32).
16. The shroud hanger assembly (30) of Claim 15, said at least one cooling cavity (33) extending below said web (142).
17. The shroud hanger assembly (30) of Claim 15, said at least one cooling cavity (33) allowing entry of cooling air into shroud hanger (32) and reducing thermal growth.
18. The shroud hanger assembly (30) of Claim 15, said at least one cooling cavity (33) being arcuate.
19. The shroud hanger assembly (30) of Claim 15, said at least one cooling cavity (33) being polygon shaped.

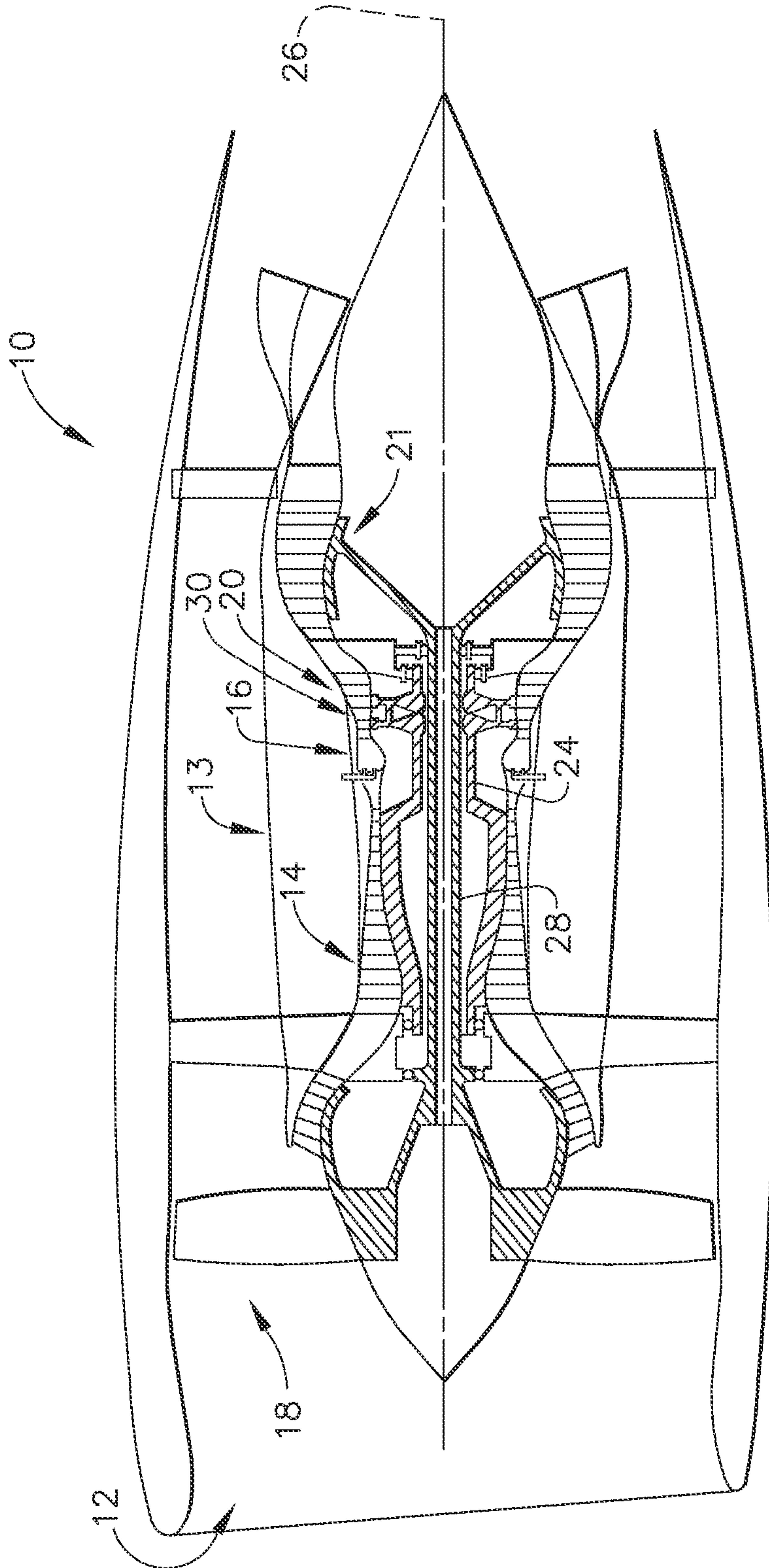

FIG. 1

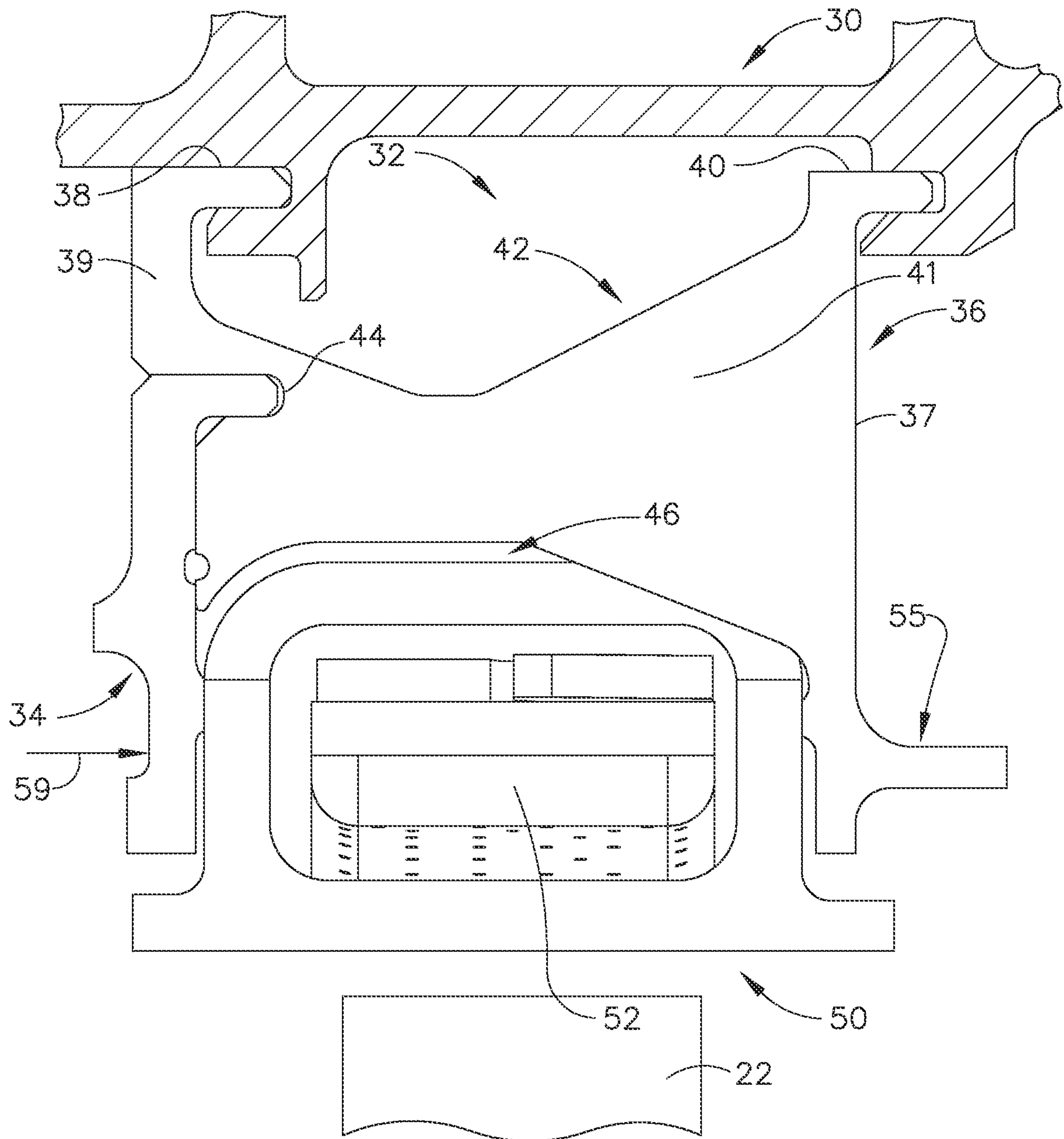

FIG. 2

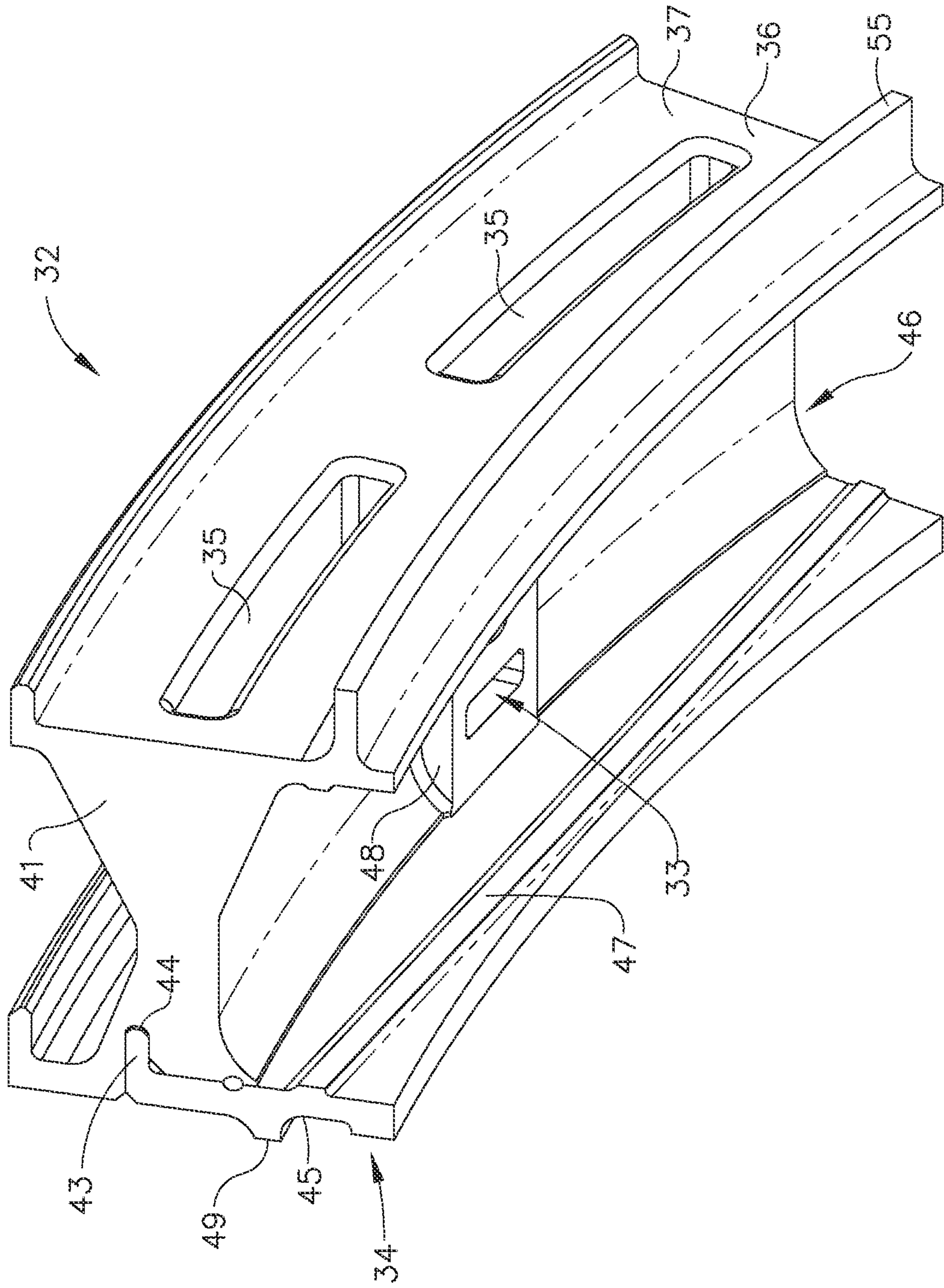

FIG. 3

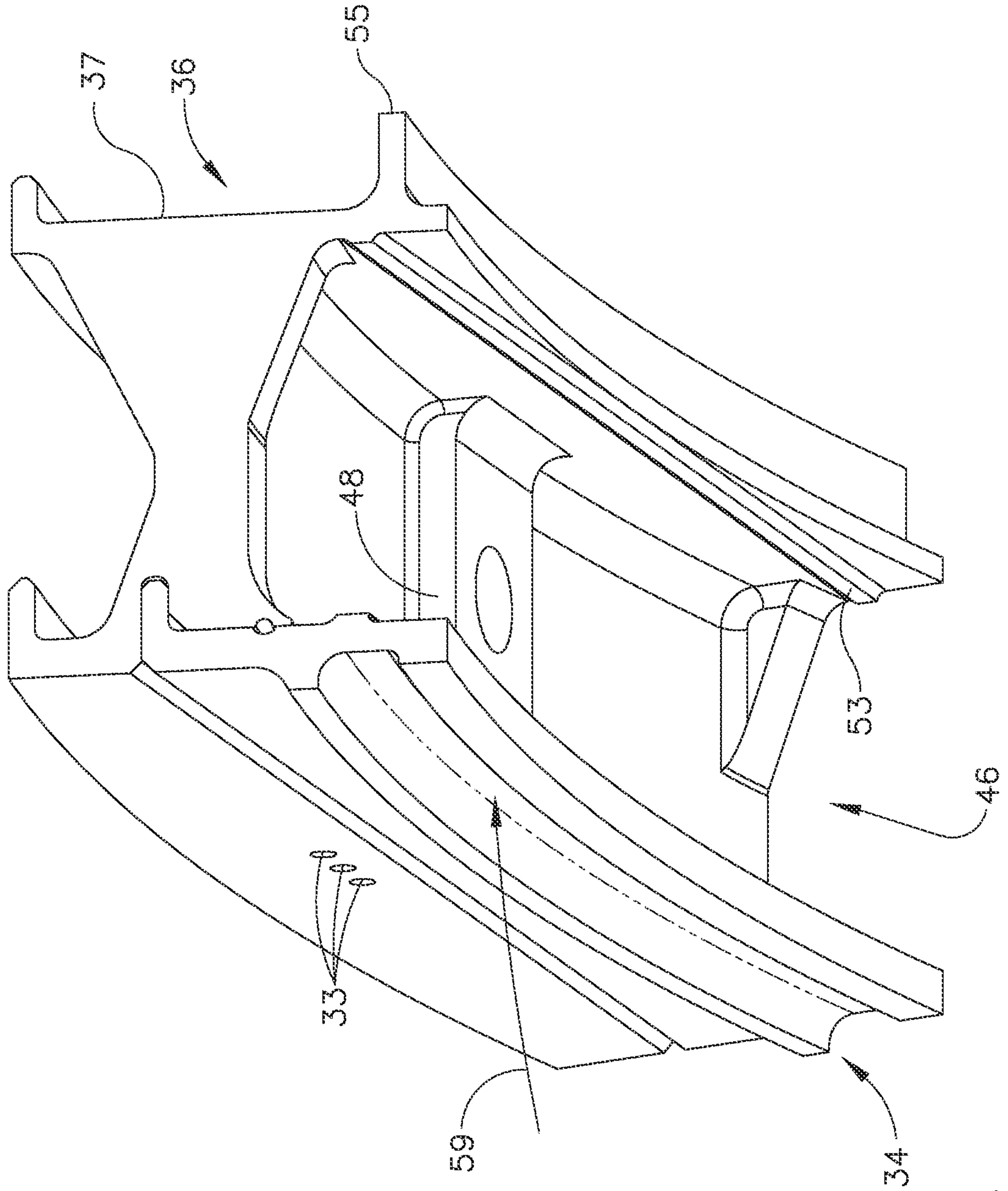

FIG. 4

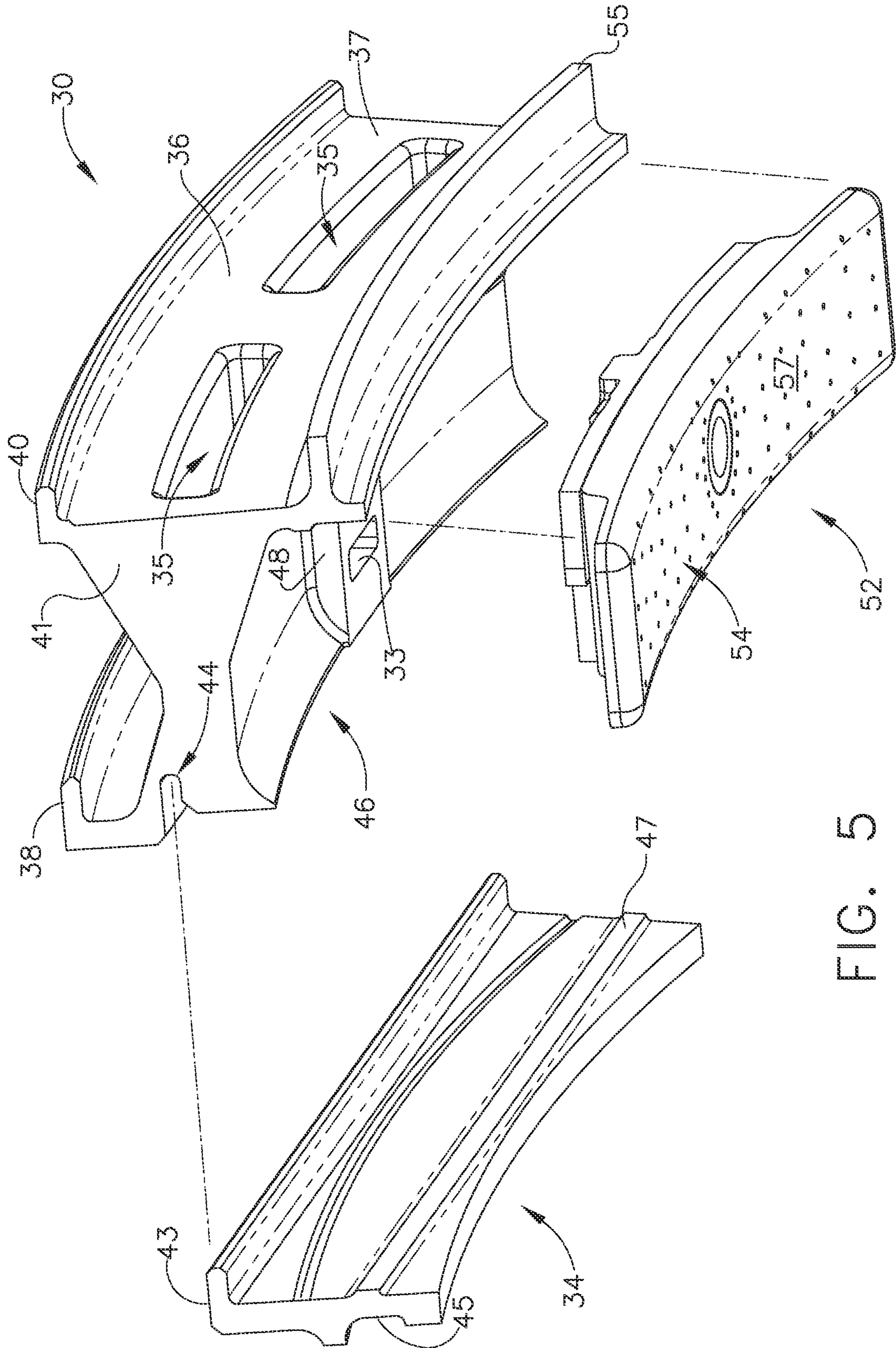

FIG. 5

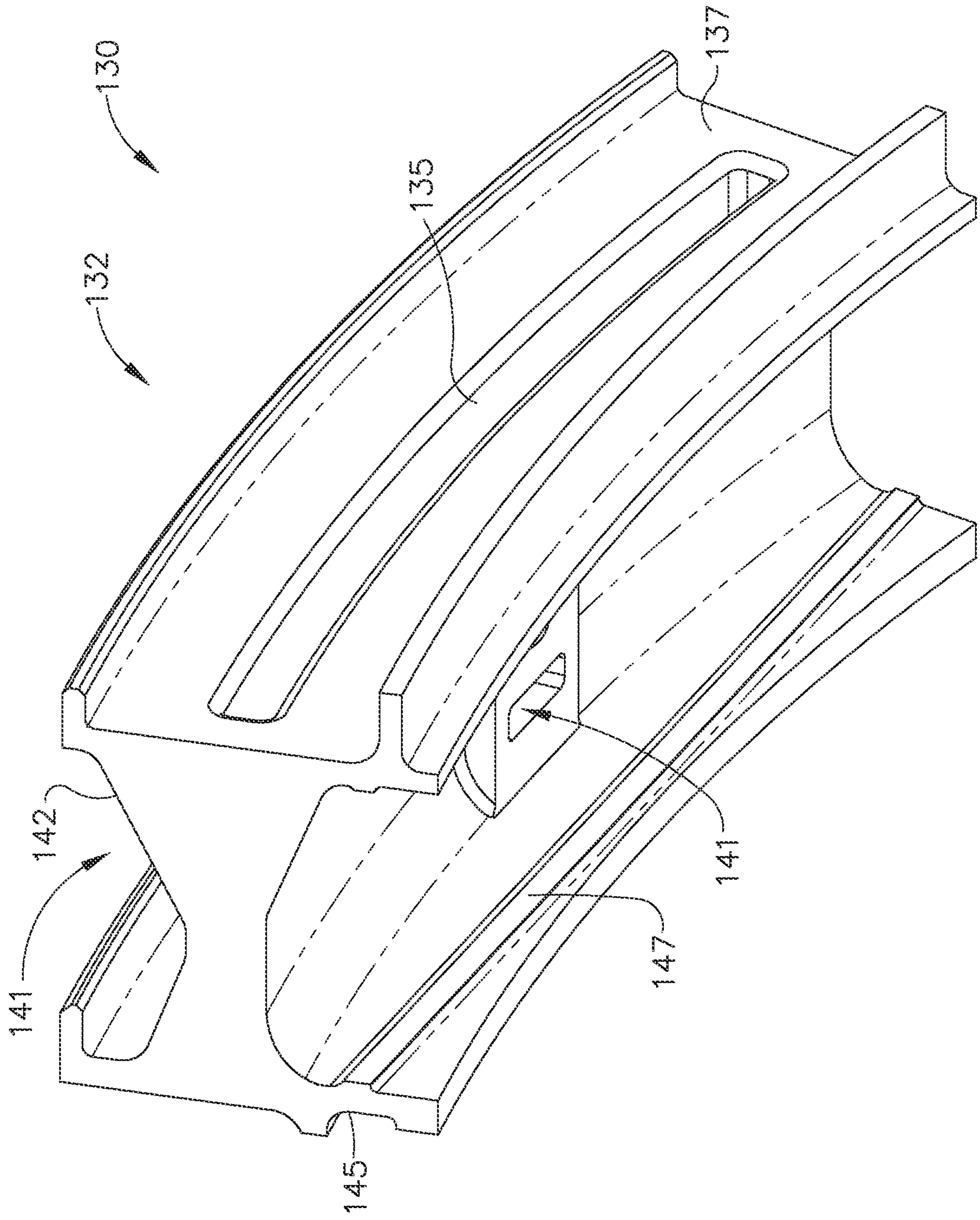

FIG. 6

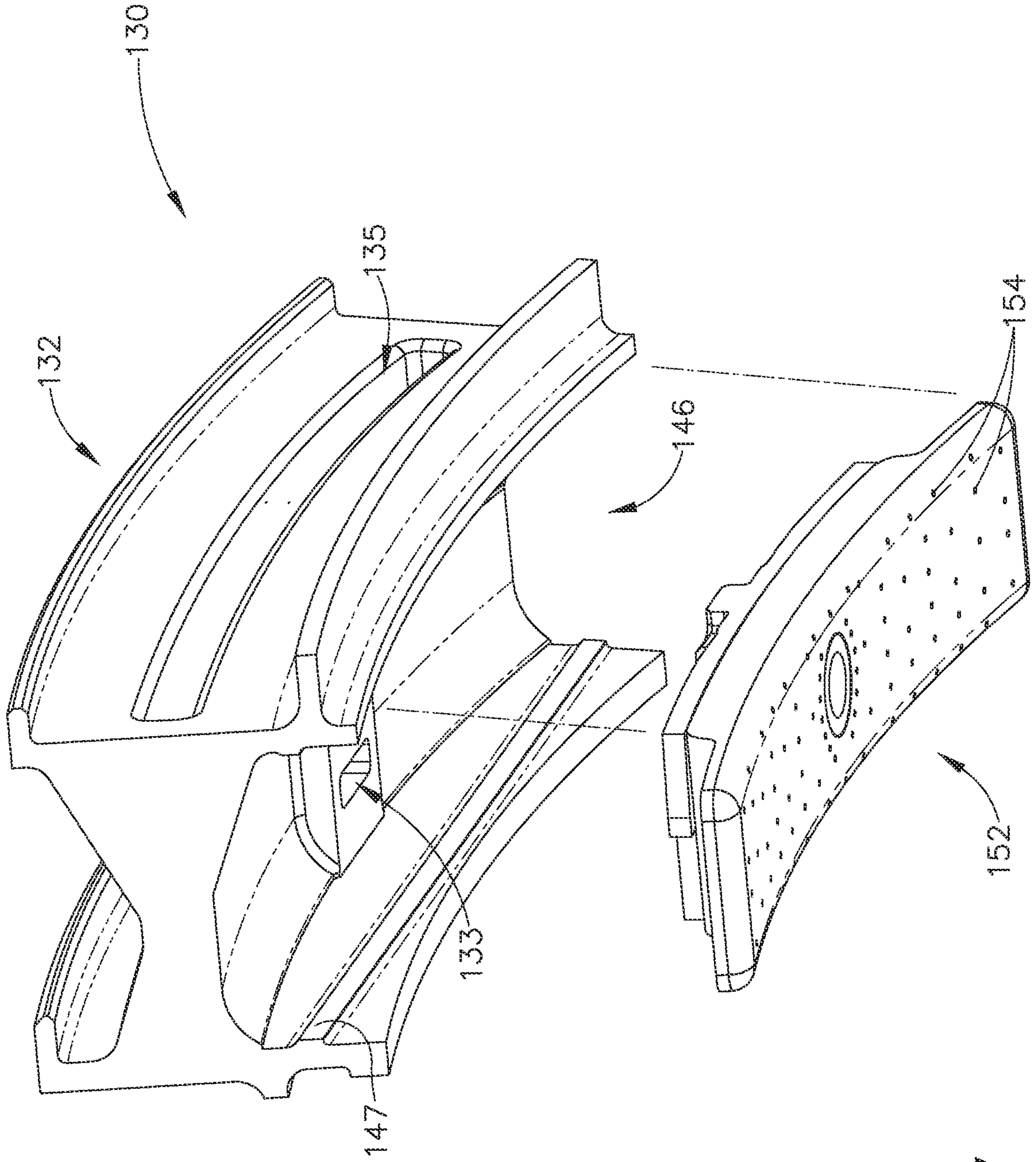

FIG. 7

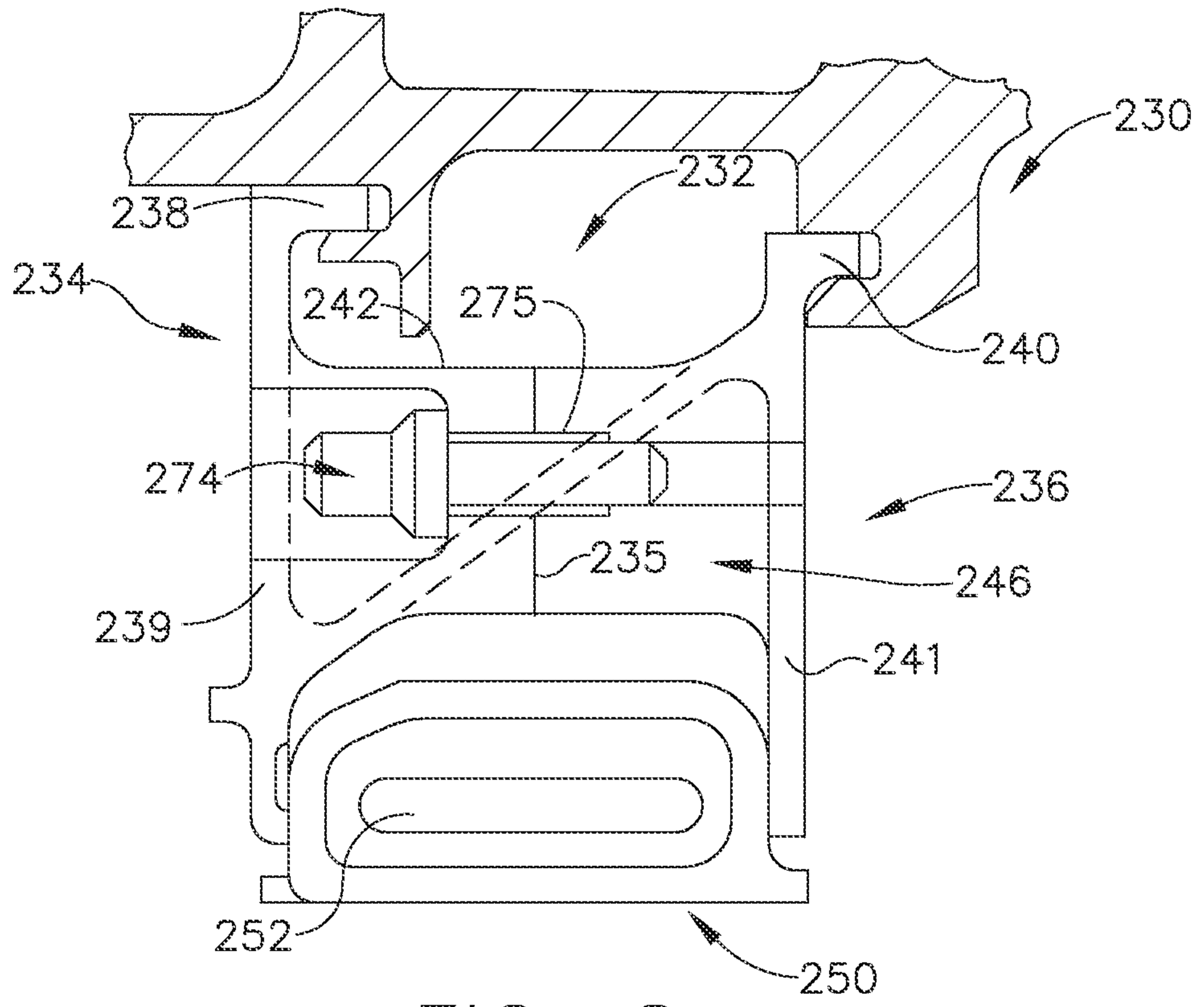

FIG. 8

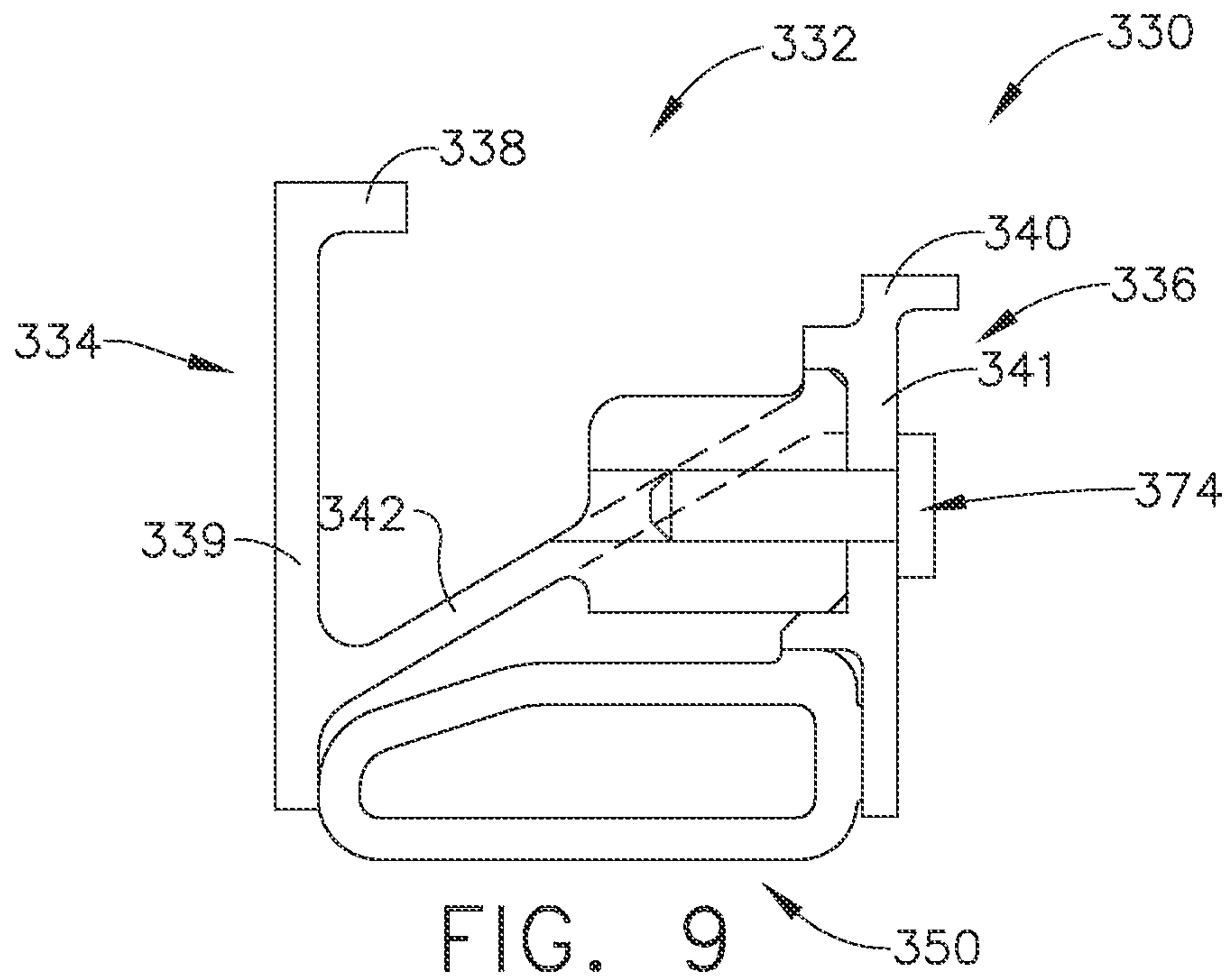

FIG. 9

