

W. BUCHANAN. Railway-Signal and Draw-Bridge Operating Device.

No. 198,449.

Patented Dec. 25, 1877.

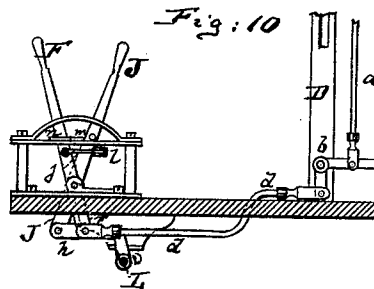
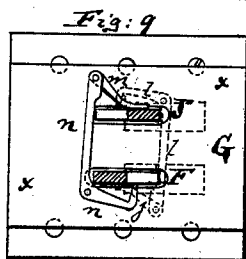
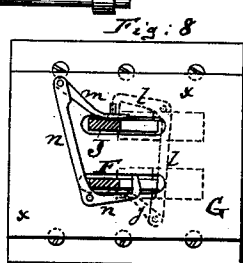
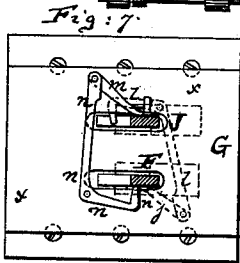
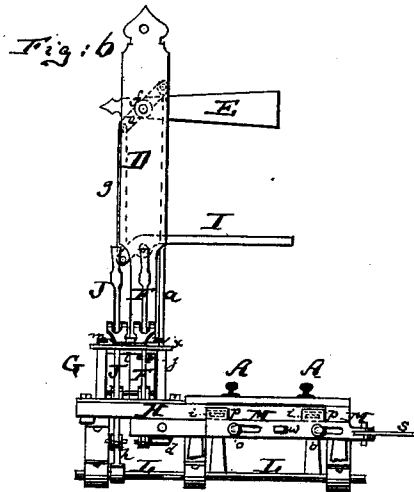
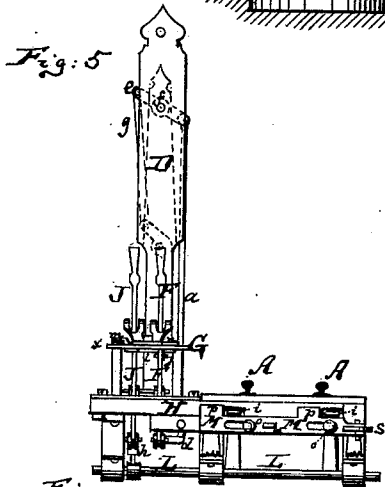
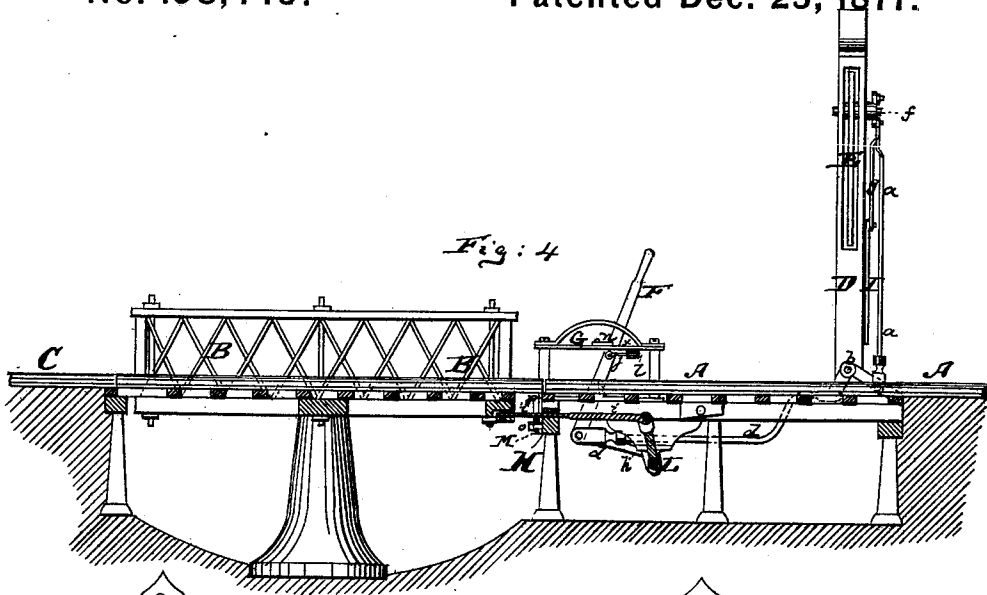

Witnesses:
John C. Sunbridge
A. P. Brown

Inventor:
William Buchanan
by his attorney
A. P. Brown

UNITED STATES PATENT OFFICE.

WILLIAM BUCHANAN, OF YONKERS, NEW YORK.

IMPROVEMENT IN RAILWAY-SIGNALS AND DRAW-BRIDGE-OPERATING DEVICES.

Specification forming part of Letters Patent No. 198,449, dated December 25, 1877; application filed November 15, 1877.

To all whom it may concern:

Be it known that I, WILLIAM BUCHANAN, of Yonkers, Westchester county, New York, have invented a new and Improved Railway-Signal and Draw-Bridge-Operating Device, of which the following is a specification:

Figure 1 is a top view of a portion of a railway-track joined to a draw-bridge, which is represented as closed. Fig. 2 is a similar view thereof, showing the bridge opened. Fig. 3 is a bottom view of said track and closed draw-bridge. Fig. 4 is a vertical longitudinal section of same. Fig. 5 is an end view of the abutment which contains the bridge-lock, showing the signal in position of "safety." Fig. 6 is alike view of the abutment, but showing the signal in position of "danger," and the bridge-locking bolt secured against motion. Figs. 7, 8, and 9 are detail top views of the mechanism for holding the bolt and signal-levers, showing them in different positions; and Fig. 10 is a detail side view of said levers and their connections.

Similar letters of reference indicate corresponding parts in all the figures.

This invention relates to a new construction of railway-signal, and to a new interlocking mechanism for the levers which move switches or bridge-locks, and those which move the signals pertaining thereto; and relates, further, to a new mechanism for securing a draw-bridge and draw-bridge lock and the operating levers, so as to insure greater safety in the use of such draw-bridges.

The invention consists of various features of improvement, hereinafter more fully pointed out, its principal object being to prevent the danger-signal, which is displayed when the bridge is open, from being set back to "safety" by any means before the bridge has been properly closed.

In the accompanying drawing, the letter A represents part of a railway-track leading to and over a draw-bridge, B, and continued beyond said bridge, as shown at C.

At a proper distance from the bridge there is erected, near the track A, a signal-post, D, in which a suitable signal, E, is held by pivot or equivalent means. This signal is, by a rod, a, bell-crank b, and rod d, or equivalent mech-

anism, connected with a lever, F, which is hung in a proper frame, G, near the abutment H of the draw-bridge.

By moving the lever F the signal E can be placed either to indicate danger, as in Fig. 6, when the bridge is open, or safety, as in Fig. 5, when the bridge is closed.

A crank, e, on the arbor f, whereon the signal E vibrates, connects by a rod, g, or otherwise, with an arm or rod, I, pivoted to the post D, as shown in Fig. 6. This rod I is made of flexible metal, or equivalent flexible material, and is, in the position of "danger," held in the path of the locomotive to strike the cab or other part of the same, and to thus indicate, by contact, that the bridge is open in front of the train.

This contact-rod or signal I is used to insure a proper warning in case the signal E should be invisible in a fog, storm, or in darkness, and may, if desired, be placed between the draw or switch and the visible signal E.

Near the lever F is hung in the frame G another lever, J, which connects by a rod, h, with a rock-shaft, L, that extends transversely beneath the track A, and is joined to one or more bolts, i i, which lock the draw-bridge when it is closed.

By vibrating the lever J the bolts i i can be moved into the bridge to lock it, or withdrawn from the bridge to allow it to be opened.

The levers F and J are pivoted side by side in the frame G, as shown. The lever F is, by a link, j, connected with a hook, l, pivoted to a platform, x, of the frame G, said hook being capable of engaging over the lever J, as indicated by dotted lines in Figs. 7, 8, 9.

In like manner the lever J connects, by a link, m, with a pivoted hook, n, which is capable of engaging over the lever F, and which is shown by full lines in Figs. 7, 8, and 9. In fact it is preferable to pivot one hook, l, to the under side, and the other, n, to the top of the platform x.

The operation of said two levers F and J, and their two locking-hooks l and n, is as follows: When the draw-bridge is closed and locked, and the signal set at "safety," the levers are both set back, as in Figs. 1 and 7. In this position the hook l engages over the bolt-

lever J, as by dotted lines in Fig. 7, so that the bridge cannot be unlocked while the signal shows a safe passage.

In order to unlock the bridge, the lever F is first moved forward into the position shown in Figs. 9 and 10, thereby setting the signal to "danger," as in Fig. 6, and unfastening the hook *l* from the bolt-lever J. The signal denoting danger, the lever J is now free to be moved forward to move the bolts that unlock the draw-bridge. This brings the levers into the position shown in Figs. 2 and 8, and causes the signal-lever F to be locked by the hook *n*. The draw-bridge may now be opened; but the signal cannot be set back to "safety" (the lever F being locked) until the draw-bridge is first relocked and the lever J brought back to its normal position. (Shown in Fig. 9.)

As far as this combination of the two levers F and J with their locking-hooks *l* and *n* is concerned, the invention is also applicable to a single switch on main line, the lever J serving to set the switch after the signal displays "danger," and to lock the signal-lever as long as the switch remains open, the signal-lever, in turn, serving to lock the switch-lever as long as the signal indicates "safety." All danger of accidents on account of misplaced switches or open draw-bridges is thus averted, as the switch or bridge cannot be moved until the danger-signal is set, which signal may be placed at any suitable distance from the switch or bridge. Nor can the danger-signal be lowered or changed until the switch or bridge is brought back to its normal position, making the track unbroken and safe for a train to pass.

Along the face of the abutment H is placed a transversely-movable plate, M, which is held in position by suitable bolts *o o*, that pass through slots, as in Figs. 5 and 6, or is otherwise properly secured to be capable of lateral motion at right angles to the direction of the track. This plate M carries projecting lugs or portions *p p*. When the bridge is unlocked, and while it is being swung open, a pin, *r*, projecting from the bridge, strikes a trigger like lever, *s*, which is pivoted to the end of the plate M, and thereby swings said trigger aside, as in Fig. 2, and moves the plate M laterally until the lugs *p p* are placed in line with, and into the path of, the bolts *i i*. This secures the unlocked bolts *i*, so that they cannot be shot out while the bridge is swung open.

Otherwise a careless bridge-tender might move the lever J and the bolts *i* into the locked position, and thereby unlock the signal-lever while the bridge is actually wide open; but by the lugs *p* the bolts *i* are prevented from moving, and with them the lever J, and, consequently, also the lever F.

When the bridge is being closed, a pin, *t*, thereon strikes a pin, *w*, that projects from the plate M, and moves the plate M so as to clear the bolts *i* from the lugs *p*. The lever J can now be moved to shoot the bolts *i* into the sockets of the bridge and lock the latter. By the motion of the plate M, last referred to, the trigger S is caused to strike the end of the abutment H, and is thereby swung into position at right angles to the plate M, as indicated in Fig. 3. Said trigger is thereby in position to be struck by the pin *r* as soon as the bridge is again opened.

It is evident that the devices above referred to may be modified in many respects. Thus, one bolt, *i*, may be used or more, than two, and different means for moving the plate M may be employed. Said plate M may be pivoted instead of sliding. Such variations are, however, of small consequence as long as the main feature of locking the bolt-lever J as soon as the bridge is moved is retained; for by this feature I prevent all danger of misleading a train by a false signal.

I claim as my invention—

1. The combination of the signal-lever F and locking-hook *l* with the bolt or switch-lever J and locking-hook *n*, all arranged to interlock, substantially as herein shown and described.
2. The combination of the lever F and signal E with the lever J, rock-shaft L, and bridge bolt or bolts *i*, substantially as herein shown and described.
3. The combination of the signal-lever F and locking device *n* with the bolt-lever J, bolt *i*, plate M, and bridge B, substantially as herein shown and described.
4. The plate M, provided with trigger *s* and with pin *w*, and combined with the pins *r* and *t* on the bridge B, substantially as herein shown and described.

WILLIAM BUCHANAN.

Witnesses:

W. J. VAN ARSDALE,
J. M. TOUCEY.