

(No Model.)

2 Sheets—Sheet 1.

J. Y. SMITH.  
BLAST OR EXHAUST APPARATUS.

No. 406,482.

Patented July 9, 1889.

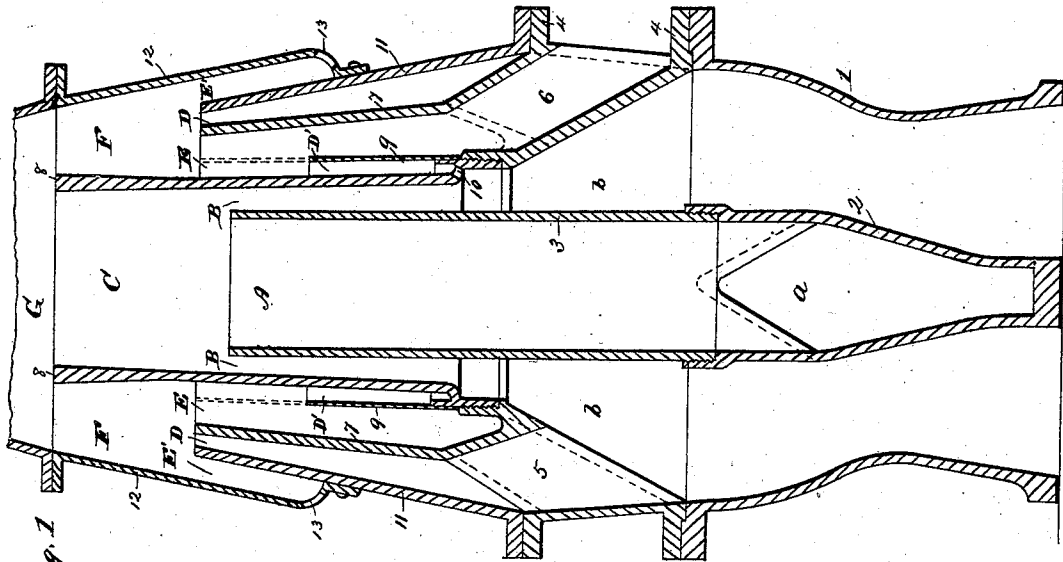

Fig. 1

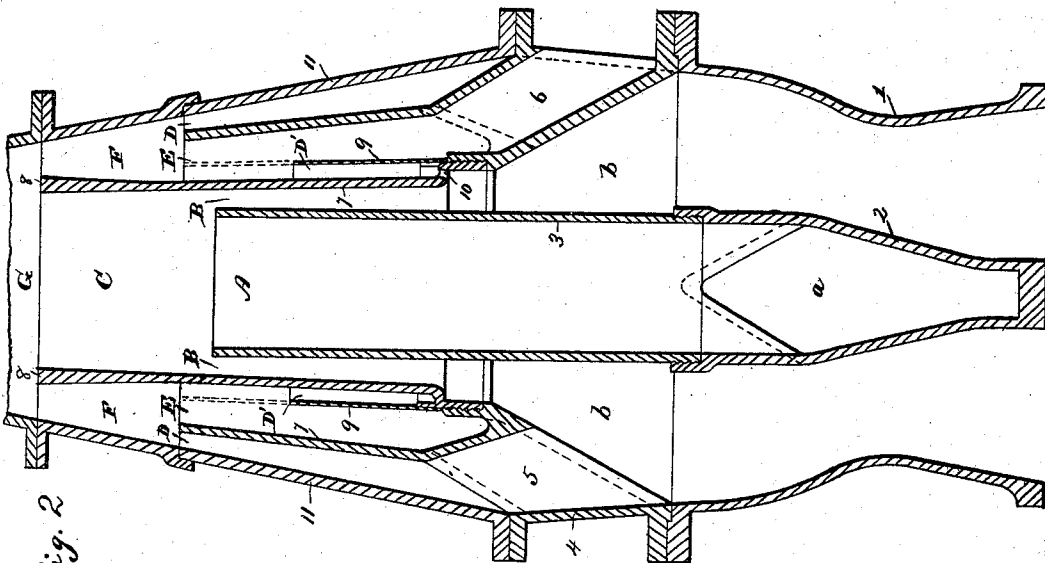

Fig. 2

Witnesses.

Chas. R. Burr.

Thomas Durant.

Inventor

John Y. Smith  
by Clark & Church  
his Attorneys.



# UNITED STATES PATENT OFFICE.

JOHN Y. SMITH, OF DOYLESTOWN, PENNSYLVANIA, ASSIGNOR TO THE  
SMITH EXHAUST PIPE COMPANY, OF NEW JERSEY.

## BLAST OR EXHAUST APPARATUS.

SPECIFICATION forming part of Letters Patent No. 406,482, dated July 9, 1889.

Application filed May 9, 1888. Serial No. 273,356. (No model.)

*To all whom it may concern:*

Be it known that I, JOHN Y. SMITH, of Doylestown, in the county of Bucks and State of Pennsylvania, have invented certain new and useful Improvements in Blast or Exhaust Apparatus; and I do hereby declare the following to be a full, clear, and exact description of the same, reference being had to the accompanying drawings, forming a part of this specification, and to the figures and letters of reference marked thereon.

In a prior patent, No. 378,340, and in an application, Serial No. 260,404, I have described and illustrated a new system or apparatus for producing and maintaining the draft in the furnace and flues of boilers, the same comprising as its principal elements inner and outer ejectors with confining-flues therefor, together with certain modifications in the construction and arrangement of parts, as well as additional features of improvement; and my present invention relates to the same general subject, and constitutes a further or additional improvement thereon, as will hereinafter be fully described, and pointed out in the claims.

In the accompanying drawings, Figure 1 is a longitudinal vertical section of my improved blast or exhaust apparatus. Figs. 2 and 3 are similar views of modified forms of the apparatus, illustrating more particularly the omission of certain features shown in the apparatus, Fig. 1. Fig. 4 is a partial section through the base of the outer ejector, showing the damper or valve for regulating the quantity of steam supplied to said ejector.

Similar letters of reference in the several figures indicate the same parts.

The letter A designates the central air-tube or inlet-passage, communicating through induction-passages *a* with the space surrounding the apparatus; B, the annular steam space or nozzle, communicating with the steam-chest *b* in the base; C, the confining flue or passage, into which the blast of steam from nozzle B is delivered and, acting upon the column of air, draws the latter through inlet-passage A and forces it into and through flue C. D is the steam-nozzle of the outer ejector; E, the air passage or inlet; F, the confining-flue of the outer ejector, into which

the products passing through D and E are delivered, and G the confining-flue common to both ejectors.

As thus far described, the construction and arrangement of parts is substantially the same as described and claimed in my prior patent and application.

Without referring to the special embodiment shown and such improvements as relate to the construction and arrangement of the various elements hereinafter to be described, the principal features of the present invention, as applied to the blast apparatus of the type specified, are, first, the addition of a supplemental steam passage or nozzle to the outer ejector, and, second, the addition of a supplemental air-passage, either or both of which improvements may be employed, the purpose and effect being to increase the capacity of the outer ejector, so that it will be enabled to accommodate and act upon a larger volume of air or gaseous matter than could otherwise be done and at the same time preserve the sharpness or strength of the blast or draft.

Referring more particularly to the devices shown in Figs. 1 and 2, it will be observed that the air-passage E of the outer ejector is larger proportionally to the area of the steam-nozzle than in my prior devices, to afford space for the passage of a larger volume of air or gas. In doing this the effective action of the outer ejector is materially diminished. The thin stream of steam entering the enlarged space, and being practically unopposed by the wider column of air or gas, expands laterally over the air-passage, producing currents or eddies at or in the mouth of the air-passage, which materially retard or diminish the enforced movement of the column of gaseous matter. To overcome this difficulty, I arrange a supplemental steam-nozzle *D'*, within and preferably below the mouth of the air-passage and receiving steam from the chamber *b*. This supplemental steam-nozzle is preferably located near or against the inner wall of the air-passage, so that the steam escaping therethrough will operate not only to assist in expelling the air or gas, but will also serve to form what may be termed an "anti-friction lining" for the air-nozzle and confining-flue, the jets of steam being driven

up in contact with the inner wall of the passage, carrying the air or gases forward and preventing retardation by contact with the wall in the same manner that steam from nozzle D prevents contact with the outer wall of the passage, so that the air or gas is drawn in and carried forward between the two moving streams of steam.

A like result—*i. e.*, increased capacity for receiving and discharging gaseous products—may also be effected by locating the steam-nozzle D between the air-passage E and an exterior supplemental air-passage E'. (Shown in Figs. 1 and 3.)

To produce the maximum effect, the supplemental steam and air passages or inlets D' E' may be employed in the same apparatus as illustrated in Fig. 1. In this case, the steam-nozzle D' is of relatively small area and opens into the air-passage at a point below the mouth thereof, the jet of steam issuing from said nozzle D' assisting in carrying the gaseous matter forward to the mouth of the passage, where it is acted upon by the larger jet issuing from nozzle D on the opposite side, and, as the steam from nozzle D' occupies a portion of the space inside nozzle D, the jet of steam issuing from the latter can operate to greater advantage on the gaseous products entering through passage E'.

Referring now to the special form of apparatus shown in illustration of one application of my said invention, 1 is the base, divided by a hollow wall 2, containing inlet-passage *a*. To the center of the hollow wall 2 is detachably secured the tube 3, containing central air-passage A. On the top of the base 1 is fastened a conical collar or cap 4, containing two series of passages, the one 5 for steam, and the other 6 for air. The section 4 carries the pipe 7, forming the inner wall of the steam-passage leading to nozzle D, and the outer wall of the passage E, and it also supports the tube 8, forming the confining-flue C and outer wall of passage leading to the nozzle B, as well as the inner wall of confining-flue F and air-passage E of the outer ejector. The pipe 8 is preferably detachably secured to section 4 as by screwing into a ring-seat, (see Figs. 1 and 2,) and the tube 9, forming the supplemental steam-nozzle D', is fastened to the lower end of said tube, which latter is perforated, as at 10, for the passage of steam. Bolted or otherwise secured to the section 4 is the flue or casing 11, forming the outer wall of the steam passage or nozzle D, and when the supplemental air-passage E' is not employed this casing is continued or prolonged beyond the nozzle D, to form the confining-flue F. (See Fig. 2.) When, however, the supplemental air-passage E' is employed, the upper end of tube 11 is removed, and an inclosing-casing 12 is secured to but held removed from said tube, and this casing is provided with inlet-openings 13.

As hereinbefore mentioned, both ejectors are preferably arranged to deliver into a

common flue or mingling-chamber G, which is secured to the upper end of casing 12, although this chamber might, as is obvious, be dispensed with and the confining-flues of both ejectors open directly into the smoke-stack or other conduit.

As it is seldom, if ever, necessary that one ejector only should be employed, and as valves, if used for this purpose, speedily become clogged up by corrosion and the formation of a deposit on their surfaces, which in time renders their movement impossible, I dispense entirely with the valves heretofore employed and substitute therefor a damper 15, resting loosely upon supports and out of contact with the steam-ports or surfaces adjacent thereto, said damper serving to regulate the amount of steam entering the outer ejector and diverting more or less into the inner ejector, without, however, at any time entirely closing the steam-ports, and, being held removed from the inner surface, the danger to be apprehended from the corrosion of the proximate surfaces or the filling up of the joints is materially lessened, if not altogether obviated. The damper is rotated on its seat or support by a crank-arm 16 on shaft 17 passing through the outer wall of the ejector, so that it can be actuated by suitable devices applied to the end thereof.

The blast apparatus, as a whole, is located in the smoke-box in front of the flues, the inlet-openings of the outer and inner ejectors being arranged at different heights with respect to the flues, as described in my prior patent and application. In order, however, to provide a means whereby the air or gases may be drawn from such portions of the smoke-box as experience and the particular construction of the boiler may render desirable, I connect to one or more of the inlet-openings—preferably to the lower one *a*, Fig. 3—a tube or conduit 20, whose outer end projects into or toward the point from whence it is desired the gaseous products or air should be drawn, and, in order that the position of this pipe may the more readily be adjusted, it is attached to a collar 21, or in any equivalent manner which will permit the pipe to be adjusted to present its outer or open end to different parts of the smoke box or chamber.

Having thus described my invention, what I claim as new is—

1. In an exhaust apparatus such as described, in combination with an annular ejector, the supplemental steam-nozzle located within the air-passage, substantially as described.

2. In combination with an ejector comprising a steam-nozzle surrounding an air inlet or passage, a supplemental steam-nozzle located in said air-passage adjacent the inner wall thereof, substantially as described.

3. In combination with the steam-nozzle, air-passage, and confining-chamber of the outer ejector, the supplemental steam-nozzle, substantially as described.

4. In an apparatus such as described, in combination with the annular steam-nozzle, inner air-passage, and confining-flue, the supplemental air-passage surrounding the steam-nozzle, substantially as described. 5
5. In an apparatus such as described, in combination with the steam-nozzle and inclosing air-passages, the supplemental steam-nozzle located in one of said air-passages, as and for the purpose set forth. 10
6. In combination with the steam-nozzle and air-passage of the outer ejector, the supplemental air-passage outside the steam-nozzle and the supplemental steam-nozzle adjacent the inner wall of the main air-passage, substantially as described. 15
7. In an apparatus such as described, containing inner and outer ejectors receiving steam through a common supply-chamber and each provided with a confining-flue in advance of their steam and air nozzles or openings, the combination, with the outer ejector, of the supplemental steam and air passages, as set forth. 20
8. In an apparatus such as described, and in combination with the flue or pipe forming the division between the inner and outer ejectors, the tube surrounding said pipe and attached thereto, and the ports formed near the base of said pipe, substantially as described. 25
9. In an apparatus such as described, the combination, with the base and hollow wall, of the removable air-tube secured to said wall, the cap or intermediate section 4, secured to the base and provided with two series of ports or passages and supporting-tubes 7 and 8, and the casing 11, detachably secured to the section 4, substantially as described. 30
10. In an apparatus such as described, containing a steam-chamber and two ejectors whose nozzles receive steam from said chamber, a damper arranged in proximity to but out of contact with the steam-ports leading to one of said nozzles, as and for the purpose set forth. 35
11. In combination with a double blast or exhaust apparatus such as described, located in the smoke-box and provided with inlet-openings at different levels, a conduit or flue extending from a remote point in the smoke-box and communicating with one of said air-inlets, as and for the purpose set forth. 40
12. In an exhaust or blast apparatus such as described, the combination, with the smoke-box and boiler-flues, of an ejector located in the smoke-box opposite the flues, and an independent flue or conduit adjustably applied to one of the air-inlets and extending laterally and opening into a remote portion of the smoke-box, substantially as described. 45
13. In combination with the air inlet or passage of an exhaust apparatus such as described, a supplemental pipe or conduit projected laterally from the blast apparatus and communicating with its air-inlet, said supplemental pipe being adjustably applied, so as to permit its outer or induction opening to be moved vertically within the smoke-box, substantially as described. 50
14. In an exhaust apparatus such as described, the combination, with a blast-pipe and air-passage co-operating therewith to form an ejector, of a supplemental tube or conduit communicating with said air-passage and having its induction end adjustable both laterally and vertically within the smoke-box, substantially as described. 55

JOHN Y. SMITH.

Witnesses:

MELVILLE CHURCH,  
THOMAS DURANT.