



(22) **Date de dépôt/Filing Date:** 2015/09/24

(41) **Mise à la disp. pub./Open to Public Insp.:** 2016/04/24

(30) **Priorité/Priority:** 2014/10/24 (US14/523,741)

(51) **Cl.Int./Int.Cl. B32B 33/00** (2006.01)

(71) **Demandeur/Applicant:**
THE BOEING COMPANY, US

(72) **Inventeur/Inventor:**
HARIRAM, SHAM S., US

(74) **Agent:** SMART & BIGGAR

(54) **Titre : APPAREIL IGNIFUGEUR ET PROCEDE DE FABRICATION**

(54) **Title: FIRE-RETARDING APPARATUS AND METHODS OF THEIR MANUFACTURE**

(57) **Abrégé/Abstract:**

A fire-retarding apparatus includes a composite. The composite includes a face layer attached to a fire-retarding layer.

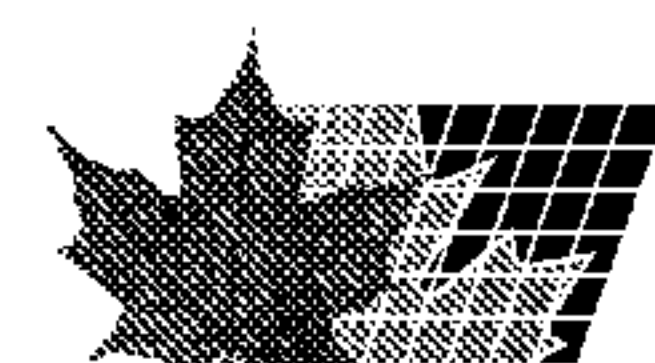

ABSTRACT

A fire-retarding apparatus includes a composite. The composite includes a face layer attached to a fire-retarding layer.

FIRE-RETARDING APPARATUS AND METHODS OF THEIR MANUFACTURE

FIELD OF THE DISCLOSURE

This disclosure relates to fire-retarding apparatus comprising composites and to
5 their methods of manufacture.

BACKGROUND

It is sometimes needed to make apparatus fire-retarding. This is often done
using heavy metal construction using materials such as Steel, Titanium, Inconel, and
other materials. However, use of such materials increases weight and expense. This is
10 an important issue in the aircraft industry where weight and cost reduction is needed.

A fire-retarding apparatus and method of manufacture is needed to resolve one
or more issues of one or more current fire-retarding apparatus or methods of
manufacture.

SUMMARY

15 In one embodiment, a fire-retarding apparatus is disclosed. The fire-retarding
apparatus includes a composite. The composite includes a face layer attached to a fire-
retarding layer.

In another embodiment, a fire-retarding apparatus is disclosed. The fire-
retarding apparatus includes a composite. The composite includes a face layer, a fire-
20 retarding layer, a fire-retarding attachment member or fire-retarding attachment layer
attaching the face layer to the fire-retarding layer, and a reinforcing layer attached to the
fire-retarding layer or reinforcing material embedded in the fire-retarding layer.

In still another embodiment, a method of manufacturing a fire-retarding apparatus is disclosed. A fire-retarding layer is attached to a face layer to form a composite.

The scope of the present disclosure is defined solely by the appended claims and is not affected by the statements within this summary.

5 **BRIEF DESCRIPTION OF THE DRAWINGS**

The disclosure can be better understood with reference to the following drawings and description. The components in the figures are not necessarily to scale, emphasis instead being placed upon illustrating the principles of the disclosure.

Figure 1 illustrates a perspective view of a fire-retarding apparatus;

10 Figure 2 illustrates a cross-section view through line 2-2 of the fire-retarding apparatus of Figure 1;

Figure 3 illustrates another embodiment of a cross-section view through line 2-2 in the fire-retarding apparatus of Figure 1;

15 Figure 4 illustrates still another embodiment of a cross-section view through line 2-2 in the fire-retarding apparatus of Figure 1;

Figure 5 illustrates yet another embodiment of a cross-section view through line 2-2 in the fire-retarding apparatus of Figure 1; and

Figure 6 is a flowchart illustrating one embodiment of a method of manufacturing a fire-retarding apparatus comprising a composite.

20 **DETAILED DESCRIPTION**

Figure 1 illustrates a perspective view of a fire-retarding apparatus 10. The fire-retarding apparatus 10 may comprise a portion of an aircraft, a portion of a spacecraft, a

portion of a vehicle, or another type of apparatus for which it is desired to be fire-retarding. For instance, in an aircraft, the fire-retarding apparatus **10** may comprise any portion of the aircraft which needs to be made fire-retarding such as the engine cowling, a nacelle which holds the engine, a cargo compartment, a housing which holds an airplane component, a skin of the aircraft, a fuselage, or another portion of the aircraft. In other embodiments, the fire-retarding apparatus **10** may further vary. The fire-retarding apparatus **10** may weigh less than **100** pounds per square foot, and may have a thickness t (shown in Figure **2**) of less than **3** feet. In other embodiments, the fire-retarding apparatus **10** may weigh less than **1** pound per square foot, and may have a thickness t (shown in Figure **2**) of less than **8** inches. In still other embodiments, the weight and thickness of the fire-retarding apparatus **10** may vary further.

Figure **2** illustrates a cross-section view through line **2-2** of the fire-retarding apparatus **10** of Figure **1**. The fire-retarding apparatus **10** may comprise a composite **12**. The composite **12** may comprise the following attached layers: face layer **14**; fire-retarding attachment layer **16**; reinforcing layer **18**; fire-retarding attachment layer **16a**; fluid-repelling layer **20**; fire-retarding layer **22**; fluid-repelling layer **20a**; fire-retarding attachment layer **16b**; reinforcing layer **18a**; fire-retarding attachment layer **16c**; and face layer **14a**. In other embodiments, any of the layers may vary in order or number, one or more of the layers may not be present, or one or more additional layers may be used. In still other embodiments, the fire-retarding apparatus **10** may consist of any combination of the layers including all of the layers or taking away one or more of the layers.

The face layers **14** and **14a** may comprise non-fire-retarding layers. The face layers may comprise sheets of aluminum, composite, metal, non-metallic, polyimide, fluid repelling, or another type of material. In other embodiments, the face layers **14** and **14a** may be made of any type of non-fire-retarding or fire-retarding material.

5 The fire-retarding attachment layers **16**, **16a**, **16b**, and **16c** may be used to adhere the layers disposed on opposite sides of them together, using a material which is fire-retarding. For purposes of this disclosure, the term “fire-retarding” means that the layer or member is made of a material which retards fire, or which doesn’t ignite or contains the fire, which prevents the fire from spreading or penetrating through, and
10 which either suppresses the fire or extinguishes it through containment and/or lack of oxygen. The fire-retarding attachment layers **16**, **16a**, **16b**, and **16c** may comprise an adhesive, paste, solid, or another adhering material which is fire-retarding. The fire-retarding attachment layers **16**, **16a**, **16b**, and **16c** may be made of ceramic, metal, non-metallic, composite, Aramid, aerogel, or polyimide. In other embodiments, the fire-retarding attachment layers **16**, **16a**, **16b**, and **16c** may be made of varying materials
15 which both adhere the layers disposed on opposite sides of them together, and are fire-retarding having fire retarding properties equivalent to Underwriter Laboratories (UL) Rating of **UL-94 V-0** (does not burn) with an operating temperature range of **-452** degrees F to **3,600** degrees F. In additional embodiments, the fire-retarding attachment
20 layers **16**, **16a**, **16b**, and **16c** may survive a fire of **2,000** degrees Fahrenheit minimum for **15** minutes without burning through and without burning the back or front sides. In still other embodiments, the fire-retarding attachment layers **16**, **16a**, **16b**, and **16c** may

vary further. In one embodiment, the fire-retarding attachment layers **16**, **16a**, **16b**, and **16c** may comprise one or more fire-retarding attachment members which are used to attach layers. The fire-retarding attachment members may comprise fire-retarding fasteners, fire-retarding clamps, fire-retarding securement members, or other types of fire-retarding attachment members. In other embodiments, any of the layers of the fire-retarding apparatus **10** may be attached to one another through/using pressing, adhesives, tape, threads, screws, bolts, fasteners, rivets, staples, clamps, other mechanical members, or other attachment mechanisms.

The reinforcing layers **18** and **18a** provide reinforcement and strength to the fire-retarding layer **22** to reduce the likelihood of the fire-retarding layer **22** tearing or disintegrating. The reinforcing layers **18** and **18a** may be made of metal, non-metallic, ceramic, glass, composite, rubber, foam, Aramid, solid, fibrous material, or porous material. In other embodiments, the reinforcing layers **18** and **18a** may be made of varying materials. In one embodiment, the reinforcing layers **18** and **18a** have a fiber density of **1.0** to **5** gm/cm³, a fiber diameter of **3** to **20** micron (um), and a fiber tensile strength of **1.0** to **6.0** Gpa (Gigapascal) to provide strength. In other embodiments, the reinforcing layers **18** and **18a** may be made of varying materials which provide strength and reinforcement. In other embodiments, instead of using separate reinforcing layers, reinforcing material may be embedded into the fire-retarding layer **22** to provide reinforcement and strength to the fire-retarding layer **22**. The reinforcing material may comprise metal, non-metallic, ceramic, glass, composite, foam, rubber, or Aramid. In other embodiments, the reinforcing material may vary. Throughout this disclosure, any

time the term “reinforcing” is used or a reference is made to reinforcement properties, the disclosure of this paragraph applies to the term.

The fluid-repelling layers **20** and **20a** may provide fluid-repelling properties to reduce the likelihood of degradation of the fire-retarding layer **22** and prevent fluid absorption. For purposes of this disclosure, the term “fluid-repelling” is defined as preventing fluid from being absorbed by the base material. The fluid-repelling layers **20** and **20a** may comprise silicone, a nano-coating, or another type of fluid-repelling material, coating, or spray. In one embodiment, the fluid-repelling layers **20** and **20a** have a fluid repellency requirement to fluid proof test equivalent to or better than ASTM **D-3393 (2009)**. In other embodiments, the fluid-repelling layers **20** and **2a** may have varying fluid repellency. Throughout this disclosure, any time the term “fluid-repelling” is used or a reference is made to fluid-repelling properties, the disclosure of this paragraph applies to the term.

The fire-retarding layer **22** comprises a material which retards fire, which doesn't ignite and contains the fire, which prevents the fire from spreading or burning through, and which either suppresses the fire or extinguishes it through containment and/or lack of oxygen. The fire-retarding layer **22** may be made of metal, non-metallic, composite, ceramic, aerogel (organic and inorganic), xerogel (organic and inorganic), polyimide, (**4,4-Oxydiphenylene-Pyromellitimide**), mineral wool, ceramic paste, ceramic coating, or an inorganic material. In other embodiments, the fire-retarding layer **22** may be made of varying materials, such as a high-temperature paste which is applied and cured, which have fire retarding properties equivalent to Underwriter Laboratories (UL) Rating of UL-

94 V-0 (does not burn) and an operating temperature range between **-100** degrees F to **3,600** degrees F. In additional embodiments, the fire-retarding layer **22** may survive a fire of **2,000** degrees Fahrenheit minimum for **15** minutes without burning through and without burning the back or front sides. In still other embodiments, the fire-retarding attachment layer **22** may vary further.

Figure **3** illustrates another embodiment of a cross-section view through line **2-2** in the fire-retarding apparatus **10** of Figure **1**. As shown, in this embodiment the fire-retarding apparatus **10** comprises a composite **12** which includes the following attached layers: face layer **14**; fire-retarding attachment layer **16**; fire-retarding layer **22**; fire-retarding attachment layer **16c**; and face layer **14a**. Reinforcing layer **18**, fire-retarding attachment layer **16a**, fluid-repelling layer **20**, fluid-repelling layer **20a**, fire-retarding attachment layer **16b**, and reinforcing layer **18a** have been eliminated from the cross-sectional embodiment of Figure **2**. In other embodiments, any of the layers may vary in order or number, one or more of the layers may not be present, or one or more additional layers may be used. In still other embodiments, the fire-retarding apparatus **10** may consist of any combination of the layers including all of the layers or taking away one or more of the layers.

Figure **4** illustrates still another embodiment of a cross-section view through line **2-2** in the fire-retarding apparatus **10** of Figure **1**. As shown, in this embodiment the fire-retarding apparatus **10** comprises a composite **12** which includes the following attached layers: fluid-repelling layer **20**; fire-retarding layer **22**; fluid-repelling layer **20a**; fire-retarding attachment layer **16c**; and face layer **14a**. Face layer **14**, fire-retarding

attachment layer **16**, reinforcing layer **18**, fire-retarding attachment layer **16a**, fire-retarding attachment layer **16b**, and reinforcing layer **18a** have been eliminated from the cross-sectional embodiment of Figure **2**. In other embodiments, any of the layers may vary in order or number, one or more of the layers may not be present, or one or more additional layers may be used. In still other embodiments, the fire-retarding apparatus **10** may consist of any combination of the layers including all of the layers or taking away one or more of the layers.

Figure **5** illustrates yet another embodiment of a cross-section view through line **2-2** in the fire-retarding apparatus **10** of Figure **1**. As shown, in this embodiment the fire-retarding apparatus **10** comprises a composite **12** which includes the following attached layers: fire-retarding layer **22**; and face layer **14a**. Face layer **14**, fire-retarding attachment layer **16**, reinforcing layer **18**, fire-retarding attachment layer **16a**, fluid-repelling layer **20**, fluid-repelling layer **20a**, fire-retarding attachment layer **16b**, reinforcing layer **18a**, and fire-retarding attachment layer **16c** have been eliminated from the cross-sectional embodiment of Figure **2**. In other embodiments, any of the layers may vary in order or number, one or more of the layers may not be present, or one or more additional layers may be used. In still other embodiments, the fire-retarding apparatus **10** may consist of any combination of the layers including all of the layers or taking away one or more of the layers.

Figure **6** is a flowchart illustrating one embodiment of a method **30** of manufacturing a fire-retarding apparatus comprising a composite. The method may be varied to manufacture any of the embodiments of the fire-retarding apparatus disclosed

herein, or varied further to manufacturing varying fire-retarding apparatus having a varying combination of layers. In step **32**, fluid-repelling layers may be attached to opposed sides of a fire-retarding layer. In step **34**, fire-retarding attachment layers may be used to attach reinforcing layers to the fluid-repelling layers attached to the opposed
5 sides of the fire-retarding layer. In other embodiments, any of the layers may be attached to one another through/using pressing, adhesives, tape, threads, screws, bolts, fasteners, rivets, staples, clamps, other mechanical members, or other attachment mechanisms. In still other embodiments, rather than attaching fire-retarding attachment layers, a reinforcing material may be embedded within the fire-retarding
10 layer. In step **36**, additional fire-retarding attachment layers may be used to attach face layers to the reinforcing layers. Optionally, fluid-repelling layers may be attached to the face layers.

In other embodiments, one or more steps of the method **30** may be varied in substance or in order, one or more steps of the method **30** may not be followed, or one
15 or more additional steps may be added to the method **30**. In still other embodiments, the method **30** may be used to manufacture a fire-retarding apparatus having any of the layers varied in order or number, having one or more of the layers not being present, or having one or more additional layers. In additional embodiments, the method **30** may be used to manufacture a fire-retarding apparatus consisting of any combination of the
20 layers including all of the layers or taking away one or more of the layers.

One or more embodiments of the disclosure may allow for composite apparatus to be made fire-retarding while keeping the fire-retarding composite apparatus low-

weight. This is a significant advantage in the airline industry where low weight leads to greater fuel efficiency thereby saving cost.

The Abstract is provided to allow the reader to quickly ascertain the nature of the technical disclosure. It is submitted with the understanding that it will not be used to interpret or limit the scope or meaning of the claims. In addition, in the foregoing Detailed Description, it can be seen that various features are grouped together in various embodiments for the purpose of streamlining the disclosure. This method of disclosure is not to be interpreted as reflecting an intention that the claimed embodiments require more features than are expressly recited in each claim. Rather, as the following claims reflect, inventive subject matter lies in less than all features of a single disclosed embodiment. Thus the following claims are hereby incorporated into the Detailed Description, with each claim standing on its own as a separately claimed subject matter.

While particular aspects of the present subject matter described herein have been shown and described, it will be apparent to those skilled in the art that, based upon the teachings herein, changes and modifications may be made without departing from the subject matter described herein and its broader aspects and, therefore, the appended claims are to encompass within their scope all such changes and modifications as are within the true scope of the subject matter described herein. Furthermore, it is to be understood that the disclosure is defined by the appended claims. Accordingly, the disclosure is not to be restricted except in light of the appended claims and their equivalents.

THE EMBODIMENTS OF THE INVENTION IN WHICH AN EXCLUSIVE PROPERTY OR PRIVILEGE IS CLAIMED ARE DEFINED AS FOLLOWS:

1. A fire-retarding apparatus comprising:

5

a composite comprising a face layer attached to a fire-retarding layer.

2. The fire-retarding apparatus of claim 1 wherein the face layer is non-fire-retarding.

10

3. The fire-retarding apparatus of claim 1 wherein the face layer comprises metal, non-metallic, composite, polyimide, or a fluid repellent coating.

4. The fire-retarding apparatus of claim 1 wherein the fire-retarding layer comprises metal, non-metallic, composite, ceramic, aerogel, xerogel, polyimide, mineral wool, (4, 4-Oxydiphenylene-pyromellitimide), ceramic paste, ceramic coating, or an inorganic material.

15

5. The fire-retarding apparatus of claim 1 further comprising a fire-retarding attachment member or fire-retarding attachment layer attaching the face layer to the fire-retarding layer.

20

6. The fire-retarding apparatus of claim 5 wherein the fire-retarding attachment member or the fire-retarding attachment layer comprises pressed layers, adhesives, tape, fasteners, fire retarding clamps, fire retarding securement members, threads, screws, bolts, fasteners, rivets, clamps, or staples

25

7. The fire-retarding apparatus of claim **1** further comprising a second face layer, wherein the fire-retarding layer is attached between the face layer and the second face layer.
- 5 **8.** The fire-retarding apparatus of claim **1** further comprising a reinforcing layer attached to the fire-retarding layer.
- 9.** The fire-retarding apparatus of claim **8** wherein the reinforcing layer comprises metal, non-metallic, composite, glass, ceramic, rubber, foam, Aramid, a solid material, a fibrous material, or a porous material.
- 10 **10.** The fire-retarding apparatus of claim **1** wherein the fire-retarding layer further comprises reinforcing material embedded in the fire-retarding layer.
- 15 **11.** The fire-retarding apparatus of claim **10** wherein the reinforcing material comprises metal, non-metallic, composite, glass, ceramic, rubber, foam, Aramid, a solid material, a fibrous material, or a porous material.
- 12.** The fire-retarding apparatus of claim **1** further comprising a fluid-repelling layer attached to the face layer or the fire-retarding layer.
- 20 **13.** The fire-retarding apparatus of claim **12** wherein the fluid-repelling layer comprises silicone, or a nano-coating.
- 25 **14.** The fire-retarding apparatus of claim **1** wherein the fire-retarding apparatus weighs less than one pound per square foot and has a thickness of less than eight inches.

15. The fire-retarding apparatus of claim **1** wherein the fire-retarding apparatus comprises a portion of an aircraft, a portion of a spacecraft, or a portion of a vehicle.
- 5 **16.** A fire-retarding apparatus comprising:
- a composite comprising a face layer, a fire-retarding layer, a fire-retarding attachment member or fire-retarding attachment layer attaching the face layer to the fire-retarding layer, and a reinforcing layer attached to the fire-retarding layer or reinforcing material embedded in the fire-retarding layer.
- 10
- 17.** The fire-retarding apparatus of claim **16** wherein the composite further comprises a fluid-repelling layer attached to the face layer, the fire-retarding layer, or the reinforcing layer.
- 15
- 18.** The fire-retarding apparatus of claim **16** wherein the fire-retarding apparatus weighs less than one pound per square foot and has a thickness of less than eight inches.
- 20 **19.** The fire-retarding apparatus of claim **16** wherein the fire-retarding apparatus comprises a portion of an aircraft, a portion of a spacecraft, or a portion of a vehicle.
- 20.** A method of manufacturing a fire-retarding apparatus comprising:
- 25
- attaching a fire-retarding layer to a face layer to form a composite.
- 21.** The method of claim **20** further comprising attaching the fire-retarding layer to the face layer with a fire-retarding attachment member or with a fire-retarding attachment layer.
- 30

22. The method of claim **20** further comprising attaching the fire-retarding layer between the face layer and a second face layer.

5 **23.** The method of claim **20** further comprising attaching a reinforcing layer to the fire-retarding layer.

24. The method of claim **20** further comprising embedding a reinforcing material in the fire-retarding layer.

10

25. The method of claim **20** further comprising attaching a fluid-repelling layer to the face layer or to the fire-retarding layer.

15

26. The method of claim **20** further comprising the formed composite weighing less than one pound per square foot and having a thickness of less than eight inches.

27. The method of claim **20** further comprising the formed composite comprising a portion of an aircraft, a portion of a spacecraft, or a portion of a vehicle.

20

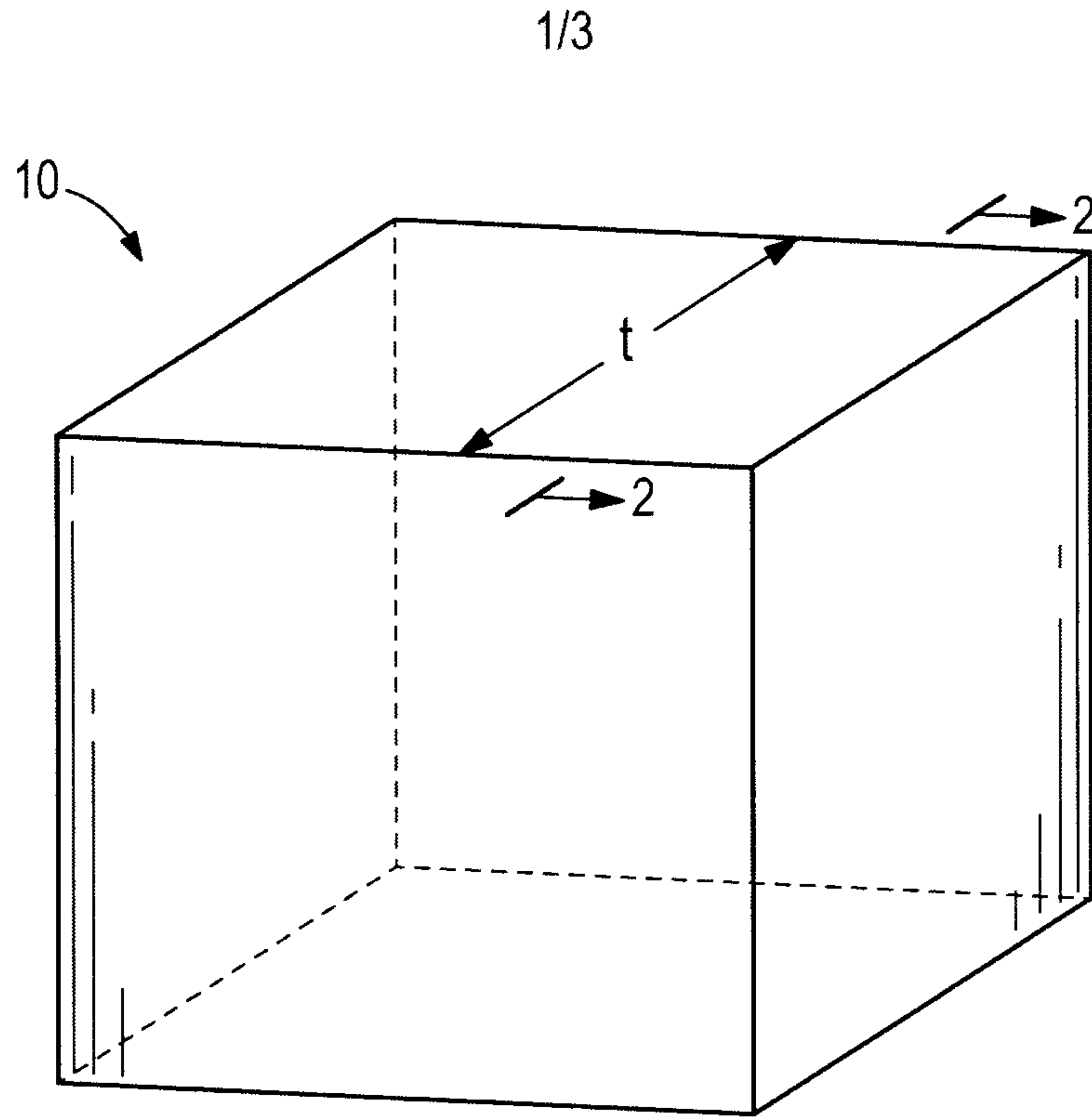

FIG. 1

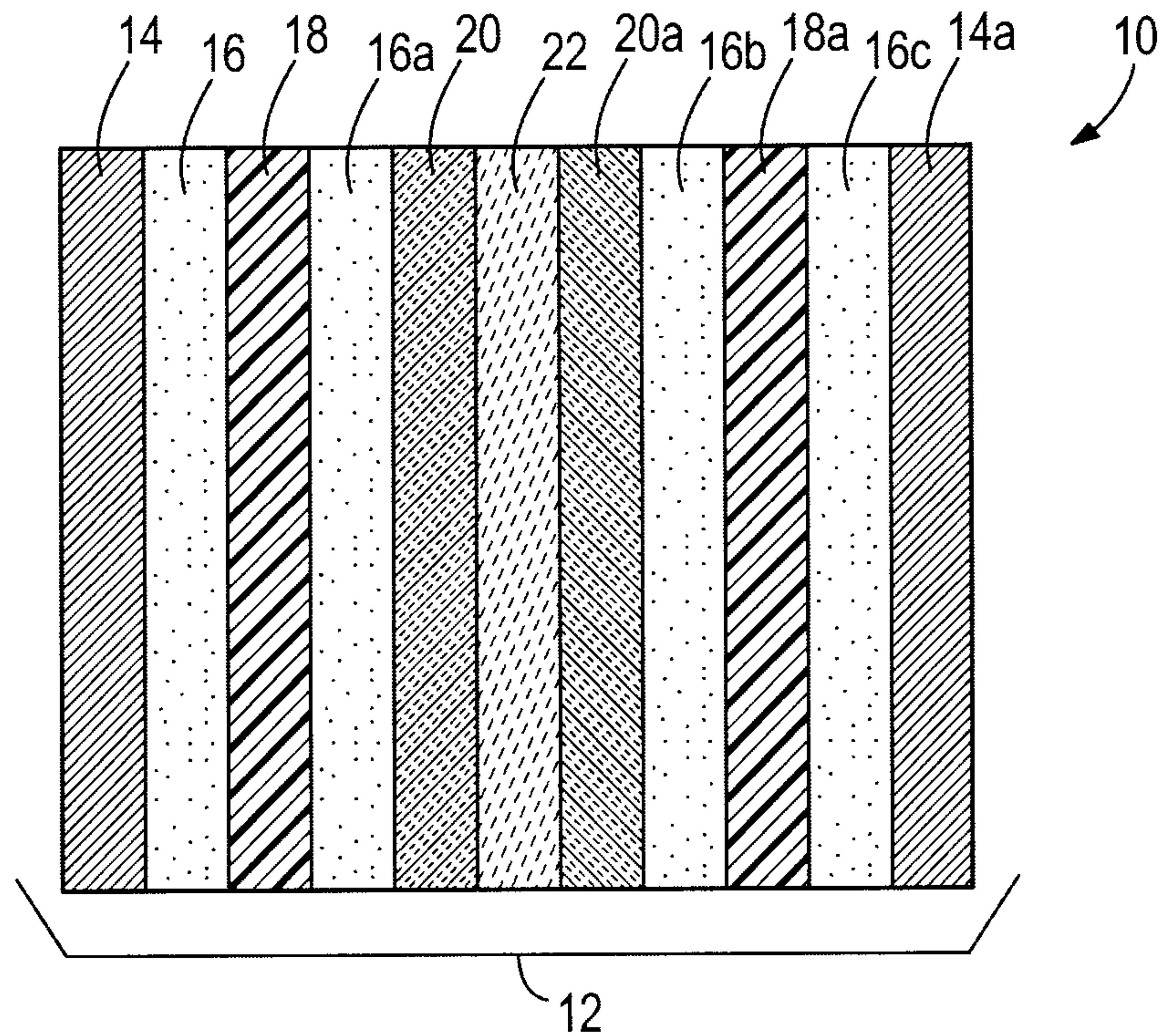

FIG. 2

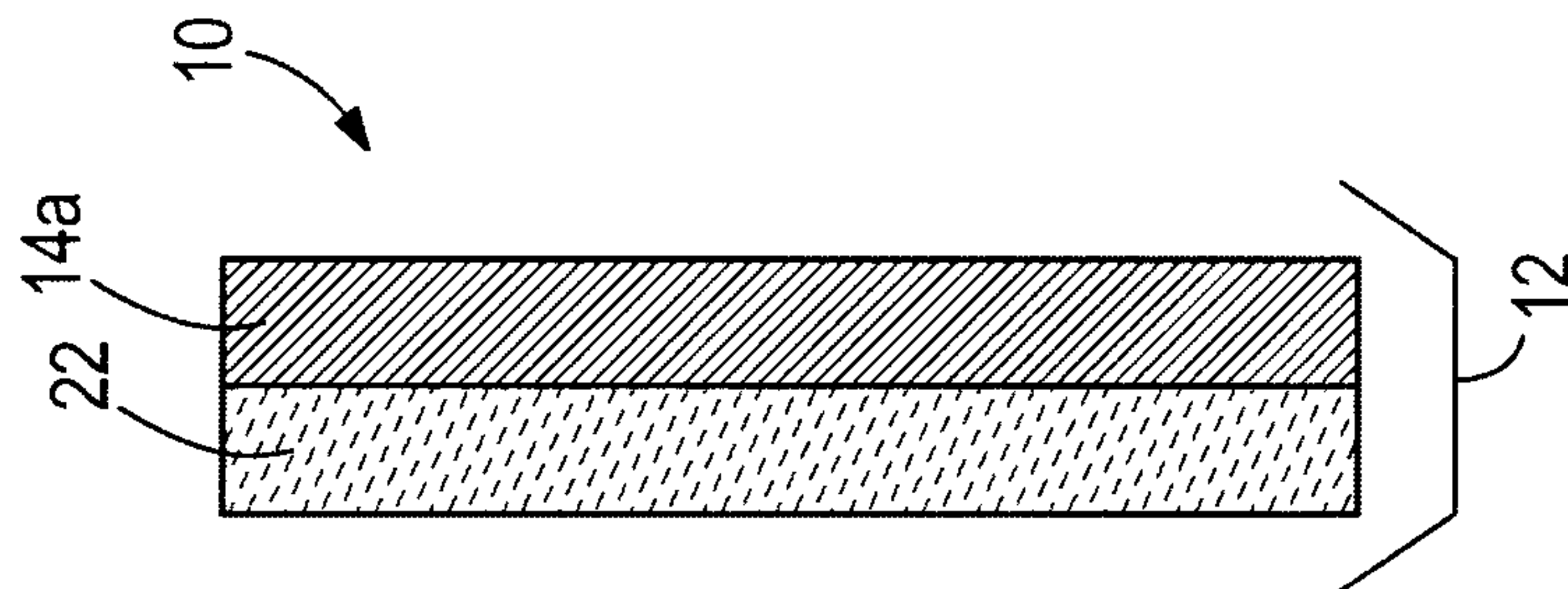

FIG. 5

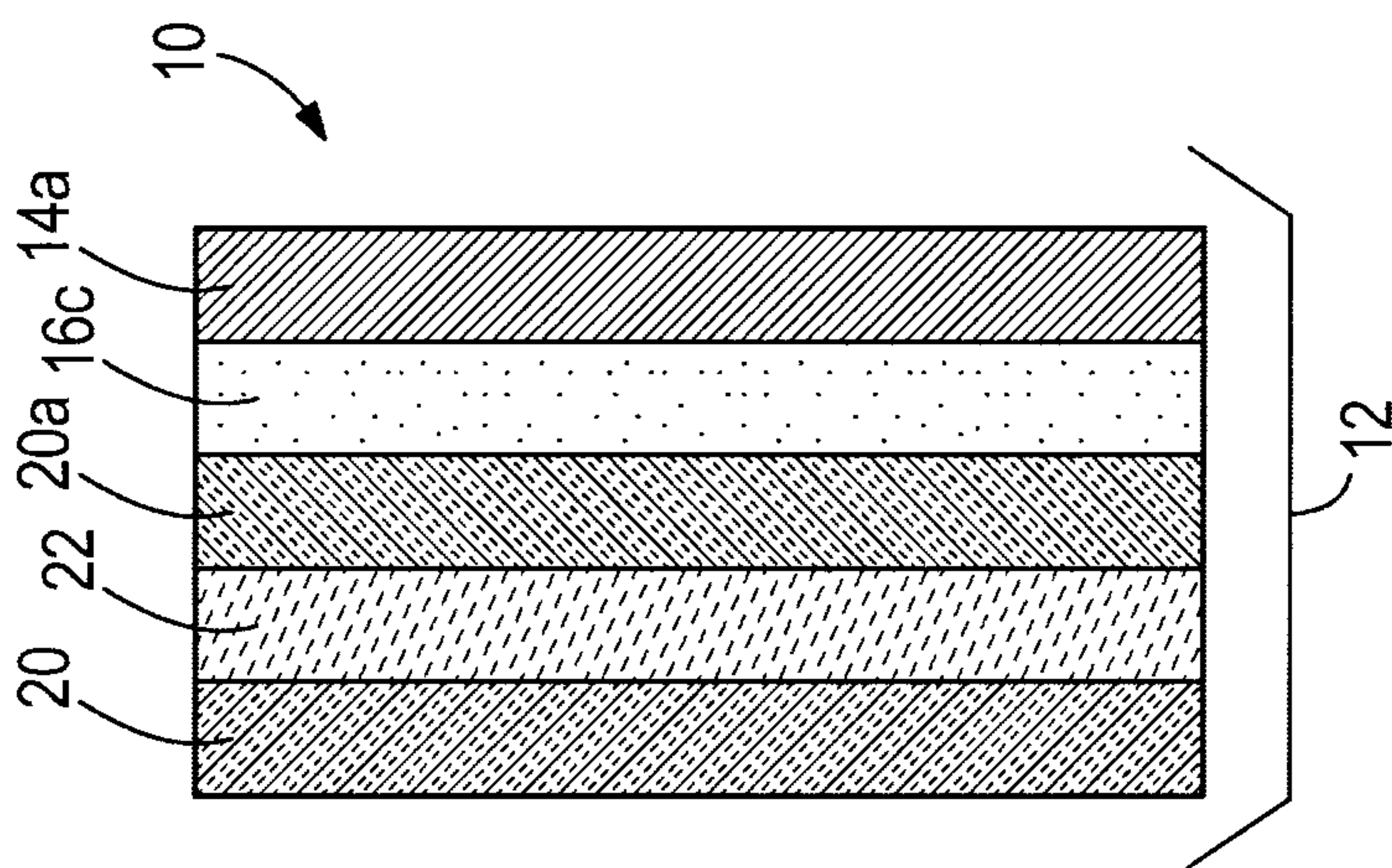

FIG. 4

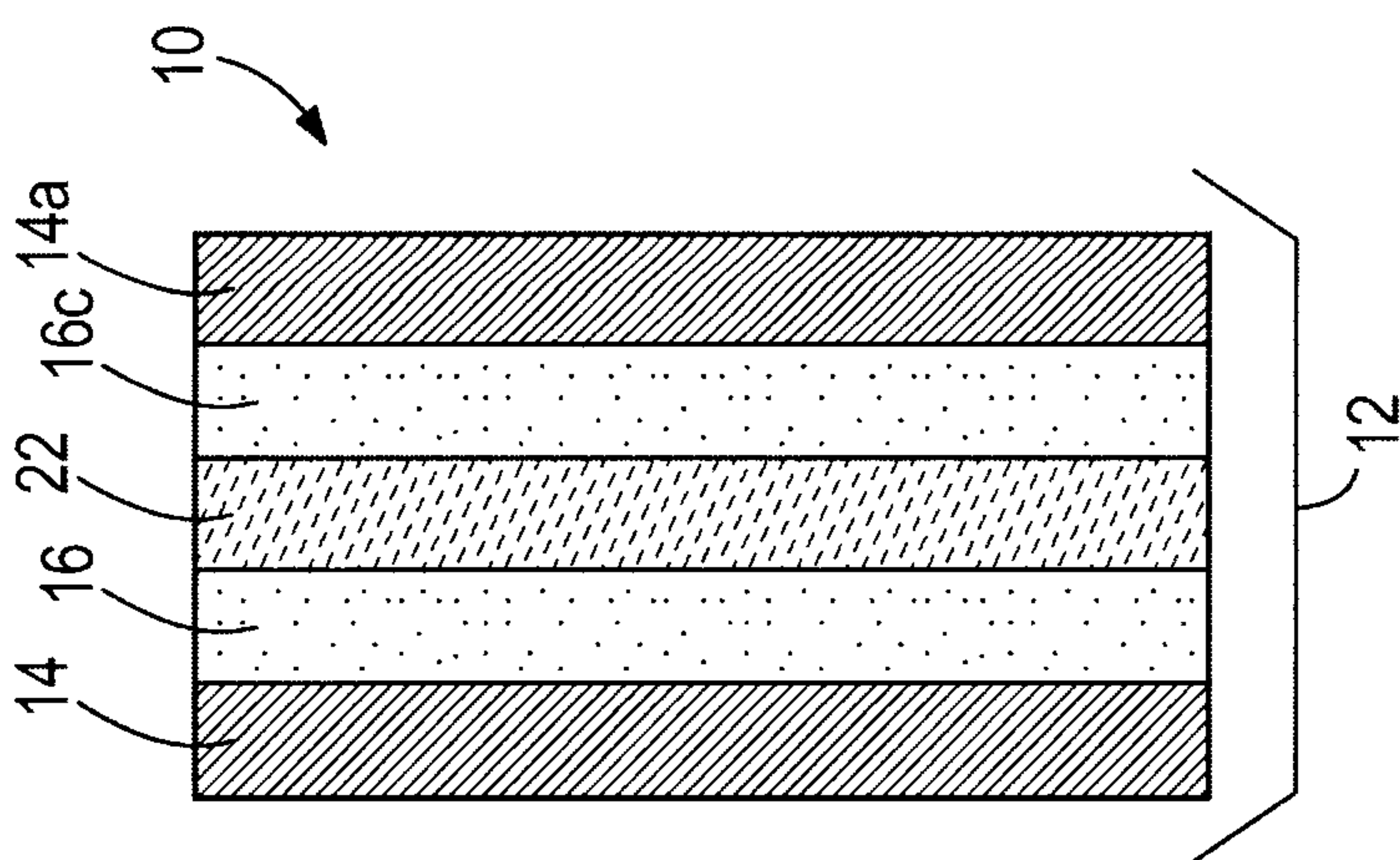

FIG. 3

3/3

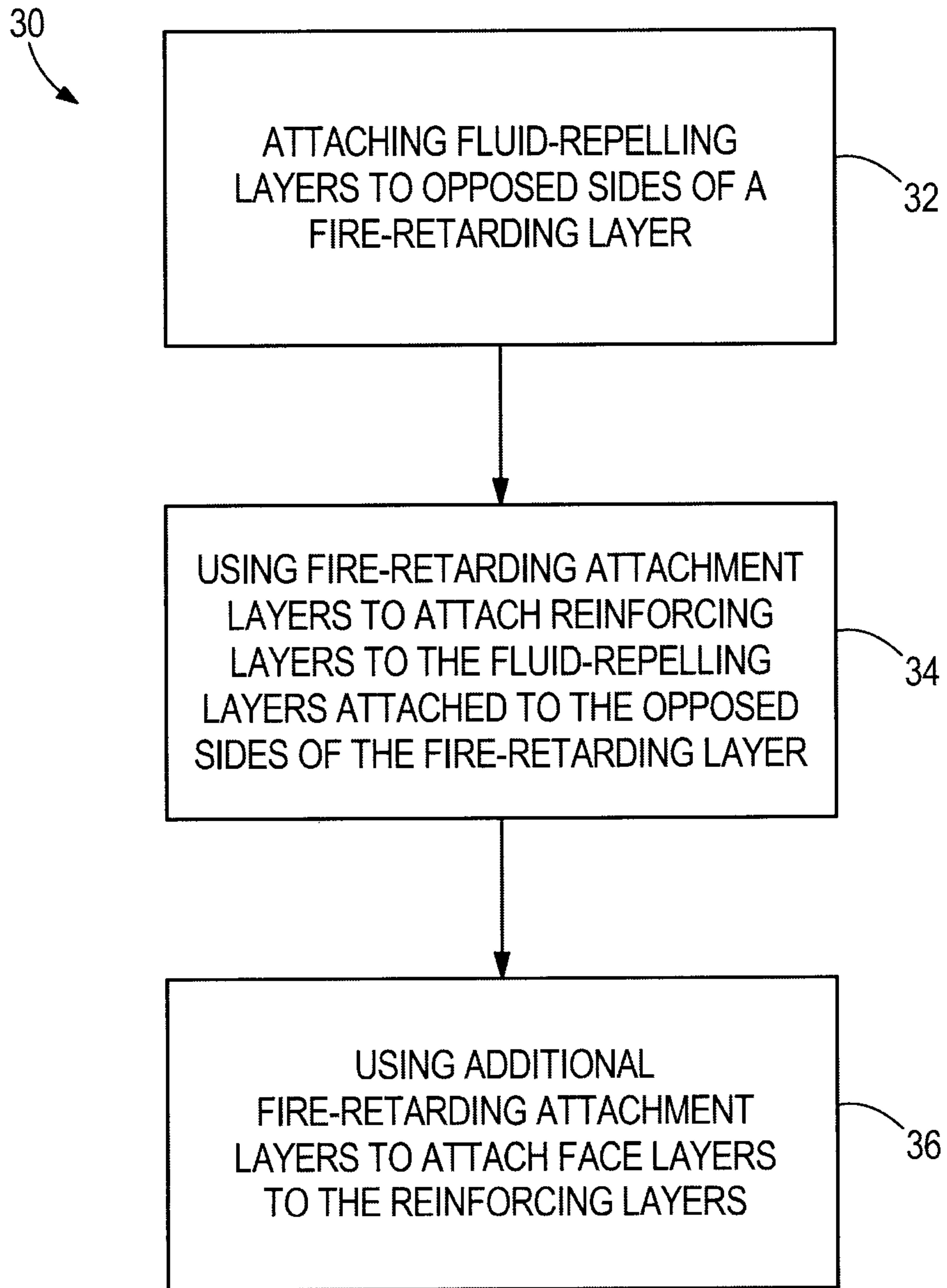

FIG. 6