

C. W. FLODQVIST.

BOILER OR VESSEL LINED WITH LEAD FOR USE IN TREATMENT OF FIBROUS SUBSTANCES.

No. 348,457.

Patented Aug. 31, 1886.

Fig. 1.

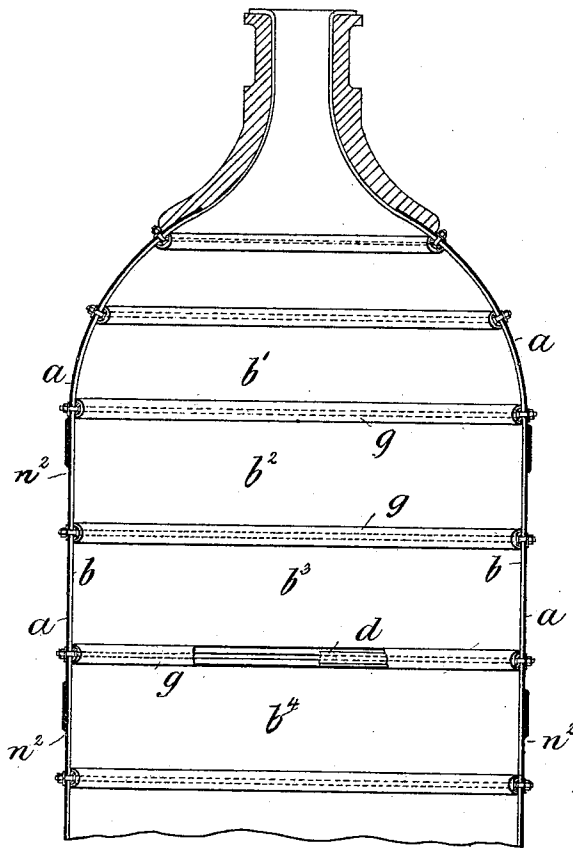
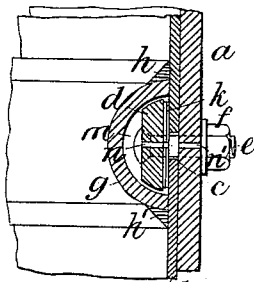

Fig. 2.



Witnesses.

H. R. M. Cready  
Robert Everett.

Fig. 4.

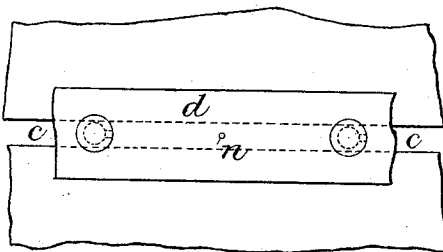
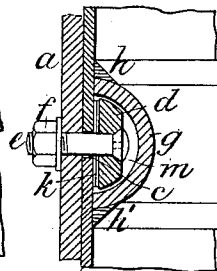

Fig. 3.



Inventor.

Carl Waldemar Flodqvist.  
By James L. Norris,  
Atty.

BOILER OR VESSEL LINED WITH LEAD FOR USE IN TREATMENT OF FIBROUS SUBSTANCES.

No. 348,457.

Patented Aug. 31, 1886.

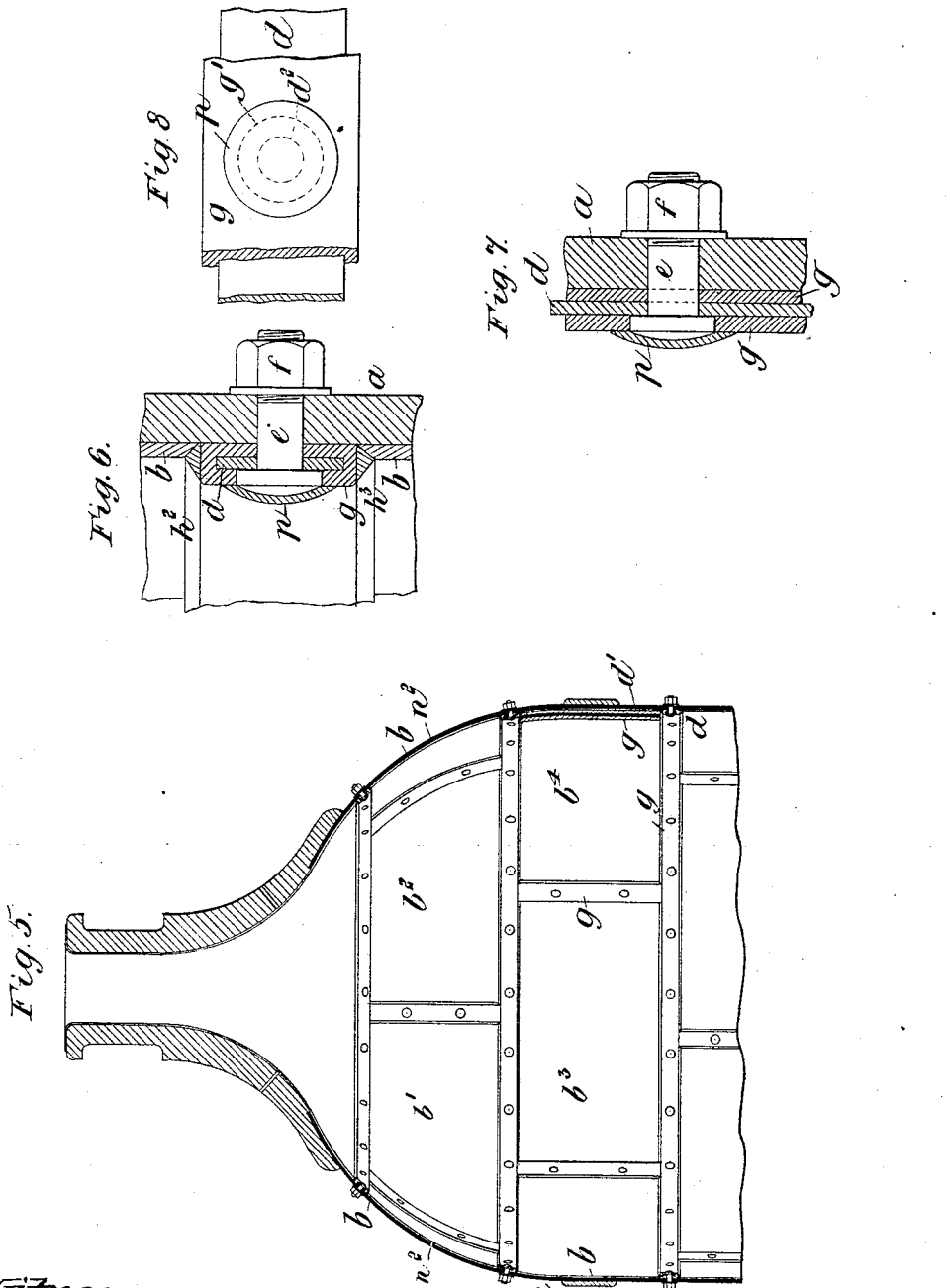

Witnesses.

H. A. M. Cready  
Robert Emmett

Inventor:  
Carl Waldemar Flodqvist.  
By James L. Norris  
Atty.

C. W. FLODQVIST.

BOILER OR VESSEL LINED WITH LEAD FOR USE IN TREATMENT OF FIBROUS SUBSTANCES.

No. 348,457.

Patented Aug. 31, 1886.

Fig. 9.

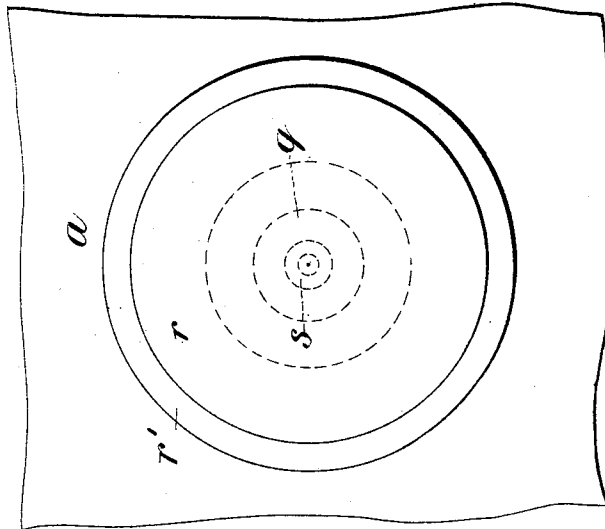
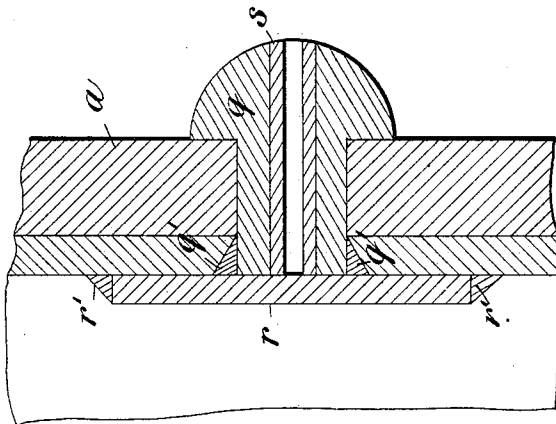

Fig. 10.



Witnesses.

*H. A. M. Cready*  
*Robert Everett*

Inventor.

*Carl Waldemar Flodqvist.*  
 By *James L. Norris*  
 Atty.

# UNITED STATES PATENT OFFICE.

CARL WALDEMAR FLODQVIST, OF GOTHENBURG, SWEDEN.

BOILER OR VESSEL LINED WITH LEAD FOR USE IN TREATMENT OF FIBROUS SUBSTANCES.

SPECIFICATION forming part of Letters Patent No. 348,457, dated August 31, 1886.

Application filed April 14, 1886. Serial No. 198,833. (No model.)

To all whom it may concern:

Be it known that I, CARL WALDEMAR FLODQVIST, engineer, a subject of the King of Sweden, and resident of Gothenburg, Sweden, have invented new and useful Improvements in Boilers or Vessels Lined with Lead for Use in the Treatment of Fibrous Substances by Means of Acids, of which the following is a specification, reference being had to the accompanying drawings.

This invention relates to boilers or vessels lined with lead for use in the treatment of fibrous substances by means of acids. An inherent defect in the lead-lined boilers heretofore used for this purpose is that the iron or steel shell of the boiler and the lead lining of the same do not expand and contract equally. Moreover, after protracted use, the lead lining becomes reduced in thickness at different parts thereof, and cracks are sometimes produced therein. To obviate these defects, I make the lead lining in sections, so that the expansion and contraction thereof will take place within such narrow limits that the liability to cracking or fracture of the said lining is reduced to a minimum and may be considered as practically removed, and to permit the free expansion and contraction of the said sections or pieces of the lining I leave clear spaces between adjacent edges of the said sections or pieces and connect them by means of lead rings, hoops, or plates, which are curved in transverse section. When the lining is heated, the sections or pieces thereof expand and their adjacent edges approach each other, the said ring or plate being more or less compressed to permit this movement of the said sections or pieces. I fasten or secure the said sections or pieces of the lining in place within the boiler-shell by means of metal rings or bands bolted or riveted to the said shell, as hereinafter described, and I so arrange the aforesaid curved plate or ring that it will cover the heads of the bolts or rivets and protect the same against the action of the acid.

My said invention, moreover, comprises the combination, with a lead rivet for securing the lining to the shell, of means for strengthening or re-enforcing the said rivet, and of a lead plate secured to the lining and covering the end of the said rivet.

In the accompanying drawings, Figure 1 is a vertical central section of part of a boiler

constructed according to my said invention, with the lining made in rings or annular or cylindrical sections. Figs. 2 and 3 are sectional views of one of the joints of the lead lining, drawn to an enlarged scale. Fig. 4 is an elevation or face view of the said joint, also drawn to an enlarged scale. Fig. 5 is a vertical central section of part of a lead-lined boiler, with the lining made in rectangular sections. Fig. 6 is a transverse section; Fig. 7, a horizontal section; and Fig. 8, an elevation or face view illustrating details of construction. Figs. 6, 7, and 8 are drawn to an enlarged scale. Figs. 9 and 10 show in front elevation and vertical central section a modification of my invention drawn to a still further enlarged scale.

$a$  is the shell of the boiler.  $b$  is the lead lining thereof, which is divided into a series of sections,  $b^1 b^2 b^3 b^4$ . In the boiler shown in Fig. 1, these sections are annular or cylindrical, and each of the said sections is, by preference, from eighteen to twenty inches in length; but they may be longer or shorter, if desired. The said sections should vary in length in proportion to the size of the boiler. Between these rings or sections are left spaces of about one inch in width, as at  $c$ , Fig. 4, to permit the said rings or sections to expand or contract without resistance.

Over each space  $c$  is placed an iron ring or band,  $d$ , of, say, three or four inches in width. These rings or bands are secured by means of bolts  $e$  and nuts  $f$  to the shell  $a$  of the boiler, so that they bind together the several sections of the lining and hold the same firmly in contact with the said shell. The said sections are, moreover, united by a flexible lead ring,  $g$ , which is placed over the iron ring  $d$ , and is soldered to the lead rings or sections  $b^1 b^2 b^3 b^4$ , as shown at  $h h'$  in Figs. 2 and 3. The ring  $g$  is designed to protect the iron ring or band against injury by the acids, and at the same time permit the expansion and contraction of the said sections, the said ring, by reason of its shape, being extended or expanded longitudinally when the lead lining contracts, and contracted when the lead lining expands.

To further facilitate the free expansion and contraction of the lead lining india-rubber packing is sometimes placed between the iron ring  $d$  and the lead lining  $b$ , as at  $k$ , Figs. 2 and 3, so that the joints will be sufficiently

elastic to prevent fracture of the lead, which would otherwise be caused by the inevitable expansion and contraction thereof.

Between the ring *g* and the iron ring *d* there is a space, *m*, Figs. 2 and 3. Air is contained in this space, and to permit its free escape therefrom holes *n* are formed in the ring *d*, and holes *n'* are formed in the shell *a* of the boiler. Therefore the air, when expanded 10 by the heat, cannot injure the lead lining. To permit the escape of air from between the rings or sections *b'* *b''* *b'''* *b''''* and the shell *a*, the latter is provided with small holes *n''*, Fig. 1.

In the boiler shown in Fig. 5 the sections *b'* 15 *b''* *b'''* *b''''* of the lead lining are of rectangular form.

In applying the lead lining in this case I secure upon the inner surface of the boiler-shell a series of iron rings or bands, *d*, about 20 two and a half inches wide, which have been previously covered with lead rings *g*. These rings or bands are placed at intervals of from one and a half to two feet, and are firmly fastened or secured by bolts *e* and nuts *f*. The 25 boiler-shell is thus divided into a number of cylindrical sections. Each of these sections is divided into, say, six or eight parts by iron bands *d'*, covered with lead and placed perpendicularly to the rings *d*, and firmly fastened to the boiler-shell by bolts *e* and nuts *f*. 30 The boiler-shell is thus divided by the said rings or bands into a large number of rectangular parts. In each of these divisions is placed a separate lead plate or section, which 35 is soldered to the edges of the adjacent rings and bands, so that when heated and cooled each separate lead plate or section will expand and contract independently of the adjacent plates or sections, and the expansion and contraction will take place within such narrow 40 limits that there will be no danger of cracks occurring in the lead. The bolts *e* are passed through holes *d''* in the rings or bands *d'*, as shown in Fig. 8, and their heads fit into holes 45 *g'* in the lead rings or coverings *g*, so that they rest against the said iron rings or bands.

*p* is a lead plate covering the head of the bolt. The lead plates or sections are soldered to the lead rings or coverings, as at *h''* *h'''*, Fig.

6. About the middle of each lead plate or 50 section there is a small hole in the iron or steel shell to let the air between the shell and the lead plate escape.

If desired, the rings or bands *d'* may be 55 secured by means of rivets, instead of as above described.

To more effectually insure the keeping of the lead plates in their position against the boiler-shell, I sometimes use the means hereinafter described, which can be applied to any 60 lead-lined boiler. The boiler-shell is provided with a number of small holes at intervals of from eight to twelve inches, and corresponding holes are formed in the lead lining. In 65 each of these holes is put a rivet, *q*, of hard lead, Figs. 9 and 10. These rivets extend through the boiler-shell and the lead lining,

and are soldered to the latter at *q'*. To 70 strengthen the lead lining at this part a round lead plate, *r*, is placed above the rivet, and soldered at *r'* to the lining *b*. To strengthen the lead rivet *q*, an iron or other metal pipe or tubular piece, *s*, is preferably placed in the center of the same, as shown.

The above-described improved manner of 75 lining the boiler with lead obviates the inconveniences arising from fracture of the lead lining, and increases the durability of the said lining, so that it will last a considerable length of time without repairs. 80

It is obvious that my improvements can be applied to boilers of other forms of construction than that shown in the drawings.

I wish it understood that I am aware that 85 it is not new to make the lead lining in sections or pieces which are united at their edges to form water-tight joints. I am also aware that it is not new to cover the bolt-heads with annular bands or hoops of lead to prevent 90 corrosion. I therefore make no claim to these devices, except when the sections or pieces are arranged with clear spaces between their edges, and when said bands or hoops are soldered to said sections or pieces, and act, as 95 above described, to take up the expansion of the lining.

What I claim is—

1. A lead-lined boiler or vessel for the purposes above specified, wherein the lead rings or sections *b'* *b''*, &c., are secured to the boiler-shell in such a manner as to leave clear spaces 100 *c* between their edges, and are connected by curved rings, bands, or hoops *g*, soldered thereto, substantially as and for the purpose set forth. 105

2. The combination, with the boiler-shell *a*, of the lead rings or sections *b'* *b''*, &c., secured thereto by the rings *d* and bolts or rivets in such a manner as to leave clear spaces *c* between their edges, and the curved 110 rings, bands, or hoops *g* connecting said lead rings or sections and covering said rings *d* and said bolts or rivets, all substantially as and for the purposes set forth.

3. The rivet *q*, of hard lead, strengthened 115 or re-enforced by the steel or iron tube *s*, substantially as and for the purposes set forth.

4. The combination, with the boiler-shell *a*, and the lead lining *b*, formed in sections and secured thereto, as above described, of 120 the rivets *q*, of hard lead strengthened or re-enforced by steel or iron tubes *s*, which rivets are passed through said shell and lining and soldered to said lining, and the lead plates *r*, covering said rivets, and also soldered to said 125 lining, substantially as and for the purpose set forth.

In testimony whereof I have hereunto signed my name in the presence of two subscribing witnesses.

Witnesses: CARL WALDEMAR FLODQVIST.

GEO. J. B. FRANKLIN,

HERBERT E. DALE,

Both of 17 Gracechurch Street, London, E. C.