

M. A. GETZENDANER.

Corn Harvester.

No. 102,532.

Patented May 3, 1870.

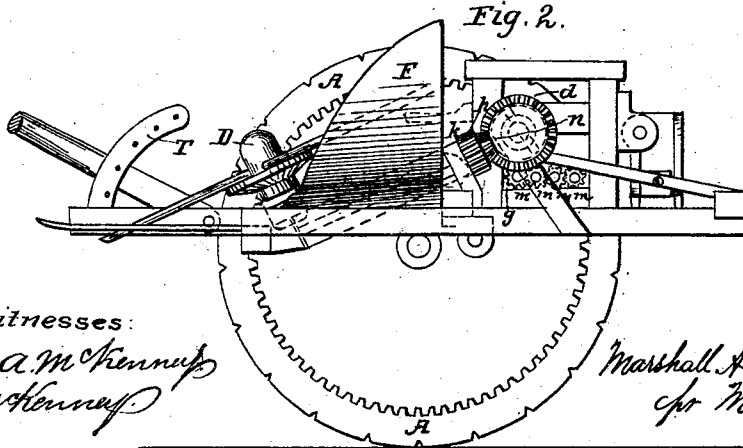
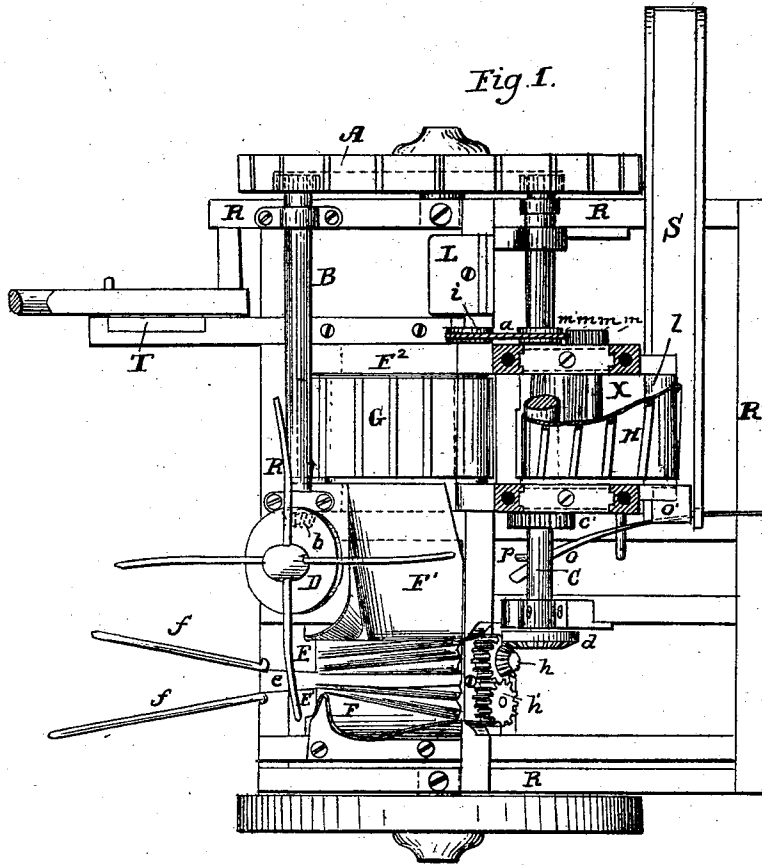

Witnesses:

Wm McKenney
J McKenney

Inventor:

Marshall A. Getzander
per McKenney & Co
his attys.

United States Patent Office.

MARSHALL A. GETZENDANER, OF POLO, ILLINOIS.

Letters Patent No. 102,532, dated May 3, 1870.

IMPROVEMENT IN CORN-HARVESTER.

The Schedule referred to in these Letters Patent and making part of the same

To all whom it may concern:

Be it known that I, MARSHALL A. GETZENDANER, of Polo, in the county of Ogle and State of Illinois, have invented a new and useful Improvement in Corn-Picking and Husking-Machines; and I do hereby declare that the following is a full, clear, and exact description thereof.

Figure 1 shows a top view of my invention.

Figure 2 shows a side elevation of the same.

Like letters indicate like parts.

The nature of my invention relates to that class of machines which are used in picking and husking corn, the power being applied by means of one of the wheels supporting the machine, the said wheel having cogs set inside the rim of the wheel, in which pinion-wheels work, transmitting motion to the machinery.

As in Figure 1, A is one of the wheels supporting the machine, having its inner rim set with cogs, which impart motion to the shafts B and C by means of pinion-wheels on the ends of the shafts, and working in the cogs.

At the other end of the shaft B is the beveled pinion-wheel *b*, working in cogs set on the under side of the reel D.

The shaft C is furnished with the grooved pulley *c*, the cog-wheel *c'*, and, at the extremity, the beveled cog-wheel *d*.

E and E' are inclined flanged cutting-rollers, having cog-wheels, *h h*, on the upper end, connecting them with each other.

The roller E has also a beveled pinion, *n*, fixed on the cog *h*, and works in the beveled cog *d* on the extremity of the shaft C.

F is a spring-board set on the outside of the rollers E and E'.

F¹ is a sliding board leading to G, which is an inclined endless apron or carrier, supported and working upon a small roller under the shaft B, and supported at the upper end by the shaft *h*, said shaft *h* being furnished with grooved pulley, *i*, over which the band *a* passes, connecting with the pulley on the shaft C, from which it receives its motion.

F² is another spring-board, set outside of the apron G.

X is the husker, consisting of the endless apron or carrier H working on the shaft C, and a smaller shaft or roller, *l*, at the rear of the machine, and the combined rollers *m' m m m*, every other one being grooved, the said rollers being set directly underneath the carrier H, which has a portion broken away in the drawing to show the working of the rollers, which are set in journal-boxes, and are furnished on the outer end with pinion-wheels working in gear with each, and received their motion from the wheel *c'* on the shaft C,

the wheel *c'* being geared in the pinion *g* on the end of the roller *m'*.

o and *o'* is the spring and block set in the rear of the frame R, and working in the end of the trough S, and is operated by engaging with the pin *p* set in the shaft C, and revolving with the same.

L is the driver's seat, and

T is the pole-supporter, perforated at equal distances, so that the pole may be raised or lowered at pleasure, the whole machine being supported upon the frame or bed R.

The operation of the machine being substantially as follows:

When set in motion, the large wheel A communicates its motion to the shafts B and C by means of the pinion-wheels on the end of said shafts B and C, and working in gear with the cogs in the rim of the wheel A.

The shaft B transmits motion to the side-motion reel D by aid of the beveled pinion *b* in gear with the cogs on the under side of the reel.

The shaft C transmits motion to the apron H, the pulley *c*, cog *c'*, and beveled cog *d*, and also to the apron or carrier G, by means of the band *a* passing over the pulley *i* on the short shaft *h*, said band, *a*, being crossed, so as to give a proper direction toward the husker X.

The cog *c'* gives motion to the pinion *g* on the end of one of the rollers of the husker, which, in turn, gives motion to another pinion, *m'*, which, being in gear with the pinions *m m m*, causes the rollers to revolve.

The beveled cog *d* on the end of the shaft C is geared with the pinion *n* on the cog-wheel *h*, which is in gear with the cog *h'*, said cog-wheels *h* and *h'* being arranged on the upper end of the flanged cutting-rollers E and E', and impart an upward motion to them.

The machine being thus in play, and driven through a field of corn, the operation will be about as follows:

The stalks of corn are caught between the guards *f f*, while the arms of the reel D push them forward between the revolving cutters E and E', which cut the stalk off just below the ear, and this is thrown on the sliding-board F¹, and passes from thence to the carrier G, by which it is carried to the husker X, and drawn into the same between the apron H and the combined rollers *m' m m m*, the aprons serving to hold the ear down on the rollers, by which the husk is torn off.

From the husker it is passed into the trough S, and is forced forward by the action of the spring and block *o o'*.

Having thus fully described the construction and operation of my improvement in corn-picking and husking-machines,

What I claim as new, and desire to secure by Letters Patent, is—

1. The spring and block σ' and σ , in connection with the pin p .

2. The combination of the rollers E and E', with the reel D, the husker X, and the spring and block σ' and σ , with the pin p , each arranged in connection with the other, as hereinbefore shown and described.

The above specification of my improvements in corn-picking and husking-machines signed this 23d day of December, 1869.

M. A. GETZENDANER. [L. S.]

Witnesses:

P. M. ENGELBRECHT.

EDW. BUCKLY.