



(51) International Patent Classification:
H04B 7/04 (2017.01)

(21) International Application Number:
PCT/CN2018/075380

(22) International Filing Date:
06 February 2018 (06.02.2018)

(25) Filing Language: English

(26) Publication Language: English

(30) Priority Data:
62/455,039 06 February 2017 (06.02.2017) US
62/501,936 05 May 2017 (05.05.2017) US
15/888,315 05 February 2018 (05.02.2018) US

(71) Applicant: **MEDIATEK INC.** [CN/CN]; No. 1, Dusing Rd. 1st, Science-Based Industrial Park, Hsin-Chu, Taiwan 300 (CN).

(72) Inventors: **YU, Chia-Hao**; No. 1, Dusing Rd. 1st, Science-Based Industrial Park, Hsin-Chu, Taiwan 300 (CN). **CHANG, Ming-Po**; No. 1, Dusing Rd. 1st, Science-Based Industrial Park, Hsin-Chu, Taiwan 300 (CN). **GUEY,**

Jiann-Ching; No. 1, Dusing Rd. 1st, Science-Based Industrial Park, Hsin-Chu, Taiwan 300 (CN).

(74) Agent: **BEIJING SANYOU INTELLECTUAL PROPERTY AGENCY LTD.**; 16th Fl., Block A, Corporate Square, No.35 Jinrong Street, Beijing 100033 (CN).

(81) Designated States (unless otherwise indicated, for every kind of national protection available): AE, AG, AL, AM, AO, AT, AU, AZ, BA, BB, BG, BH, BN, BR, BW, BY, BZ, CA, CH, CL, CN, CO, CR, CU, CZ, DE, DJ, DK, DM, DO, DZ, EC, EE, EG, ES, FI, GB, GD, GE, GH, GM, GT, HN, HR, HU, ID, IL, IN, IR, IS, JO, JP, KE, KG, KH, KN, KP, KR, KW, KZ, LA, LC, LK, LR, LS, LU, LY, MA, MD, ME, MG, MK, MN, MW, MX, MY, MZ, NA, NG, NI, NO, NZ, OM, PA, PE, PG, PH, PL, PT, QA, RO, RS, RU, RW, SA, SC, SD, SE, SG, SK, SL, SM, ST, SV, SY, TH, TJ, TM, TN, TR, TT, TZ, UA, UG, US, UZ, VC, VN, ZA, ZM, ZW.

(84) Designated States (unless otherwise indicated, for every kind of regional protection available): ARIPO (BW, GH, GM, KE, LR, LS, MW, MZ, NA, RW, SD, SL, ST, SZ, TZ, UG, ZM, ZW), Eurasian (AM, AZ, BY, KG, KZ, RU, TJ, TM), European (AL, AT, BE, BG, CH, CY, CZ, DE, DK, EE, ES, FI, FR, GB, GR, HR, HU, IE, IS, IT, LT, LU, LV, MC, MK, MT, NL, NO, PL, PT, RO, RS, SE, SI, SK, SM,

(54) Title: MECHANISM FOR BEAM RECIPROCITY DETERMINATION AND UPLINK BEAM MANAGEMENT

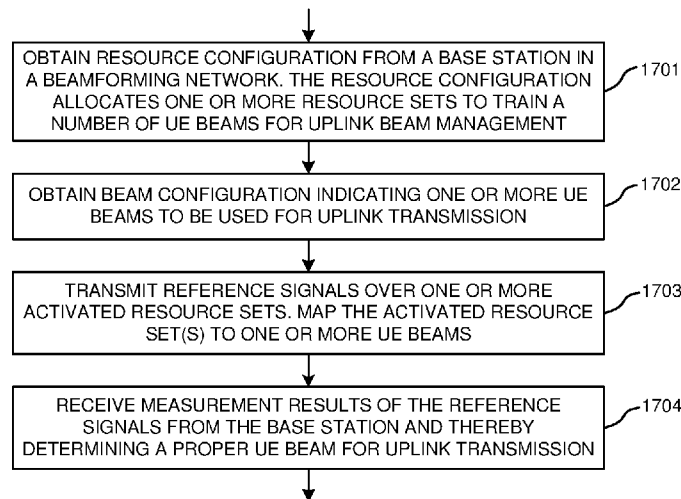

FIG. 17

(57) Abstract: A method of beam reciprocity state reporting and uplink beam management in wireless communication systems with beamforming is proposed. In one novel aspect, a BS configures one or more resource sets to a UE for uplink beam management. The one or more resource sets are allocated for UE to transmit UL reference signals using a number of UE beams. The number of UE beams to be trained is reported by the UE, e.g., via a "UE beam reciprocity state (update)" message. The BS also indicates whether a fixed UE TX beam or which UE TX beam is used for transmission, or indicates whether different UE TX beams are used for transmission of different resources in a resource set. The BS then feedback measurement results for UE to choose a proper TX beam.



TR), OAPI (BF, BJ, CF, CG, CI, CM, GA, GN, GQ, GW,
KM, ML, MR, NE, SN, TD, TG).

Published:

— *with international search report (Art. 21(3))*

MECHANISM FOR BEAM RECIPROCITY DETERMINATION AND

UPLINK BEAM MANAGEMENT

CROSS REFERENCE TO RELATED APPLICATIONS

[0001] This application claims priority under 35 U.S.C. §119 from U.S. Provisional Application
5 Number 62/455,039, entitled “Mechanism for Beam Reciprocity Determination and UL Beam
Management,” filed on February 6, 2017; U.S. Provisional Application Number 62/501,936, entitled
“Method for Beam Management for Wireless Communication System with Beamforming,” filed on
May 5, 2017, the subject matter of which is incorporated herein by reference.

TECHNICAL FIELD

10 [0002] The disclosed embodiments relate generally to wireless communication, and, more
particularly, to beam reciprocity determination and uplink beam management in a Millimeter Wave
(mmW) beamforming system.

BACKGROUND

[0003] The bandwidth shortage increasingly experienced by mobile carriers has motivated the
15 exploration of the underutilized Millimeter Wave (mmWave) frequency spectrum between 3G and
300G Hz for the next generation broadband cellular communication networks. The available
spectrum of mmWave band is two hundred times greater than the conventional cellular system. The
mmWave wireless network uses directional communications with narrow beams and can support
multi-gigabit data rate. The underutilized bandwidth of the mmWave spectrum has wavelengths
20 ranging from 1mm to 100mm. The very small wavelengths of the mmWave spectrum enable large
number of miniaturized antennas to be placed in a small area. Such miniaturized antenna system can
produce high beamforming gains through electrically steerable arrays generating directional
transmissions. With recent advances in mmWave semiconductor circuitry, mmWave wireless system
has become a promising solution for real implementation. However, the heavy reliance on directional
25 transmissions and the vulnerability of the propagation environment present particular challenges for

the mmWave network with beamforming.

[0004] For beamformed access, both ends of a link, e.g., both base station (BS) and user equipment (UE), need to know which beamformers to use. In downlink DL-based beam management, the BS side provides opportunities for UE to measure beamformed channel of different combinations of BS beams and UE beams. For example, BS performs periodic beam sweeping with reference signal (RS) carried on individual BS beams. UE can collect beamformed channel state by using different UE beams, and UE then report the collect information to BS. Similarly, in uplink UL-based beam management, the UE side provides opportunities for BS to measure beamformed channel of different combinations of UE beams and BS beams. For example, UE performs periodic beam sweeping with reference signal (RS) carried on individual UE beams. BS can collect beamformed channel state by using different BS beams, and BS then report the collect information to UE.

[0005] UE Beam reciprocity state affects whether additional UL-based beam management is required. Beam reciprocity at BS holds if BS is able to determine a BS RX beam for the UL reception based on UE's DL measurement on BS's one or more TX beams, and if BS is able to determine a BS TX beam for the DL transmission based on BS's UL measurement on BS's one or more RX beams. Similarly, reciprocity at UE holds if UE is able to determine a UE RX beam for the DL reception based on BS's UL measurement on UE's one or more TX beams, and if UE is able to determine a UE TX beam for the UL transmission based on UE's DL measurement on UE's one or more RX beams.

[0006] UL beam management consumes additional resources heavily and should be minimized. With beam reciprocity or partial beam reciprocity at UE, UL beam management overhead can be reduced. Therefore, it is desirable for UE to report its beam reciprocity to the network for proper UL beam management.

SUMMARY

[0007] A method of beam reciprocity state reporting and uplink beam management in wireless communication systems with beamforming is proposed. In one novel aspect, a UE determines its UE beam reciprocity state and sends a "UE beam reciprocity state" message to a BS, which triggers proper uplink beam management accordingly. The UE beam reciprocity state message can take place when UE tries to register to the network. For example, according to factory setting, UE reports at least "Positive" or "Negative" in this message. Beam reciprocity state can be updated by a "UE beam reciprocity state update" message. An auxiliary information can be transmitted to the BS for UL beam management if UE reports "Negative" for beam reciprocity state. The auxiliary information indicates the uncertainty level of UE beams.

[0008] In one embodiment, a user equipment (UE) obtains a beam reciprocity state in a beamforming communication network. The UE provides the beam reciprocity state to a base station. The beam reciprocity state indicates a positive or negative UE beam reciprocity state. The UE performs an uplink beam management procedure when the beam reciprocity state indicates the negative beam reciprocity state. The UE receives resource configuration from the base station and transmits reference signals over the configured resource using corresponding UE beams for uplink beam management.

[0009] In another embodiment, a base station (BS) receives a beam reciprocity state from a user equipment (UE) in a beamforming communication network. The beam reciprocity state indicates positive, negative, or unsure UE beam reciprocity. The BS triggers an uplink beam management procedure when the beam reciprocity state indicates negative UE beam reciprocity. The beam management procedure involves configuring resource and receiving reference signals over the configured resource with corresponding UE beams.

[0010] In one novel aspect, a BS configures one or more resource sets to a UE for uplink beam management. The one or more resource sets are allocated for UE to transmit UL reference signal using a number of UE beams. The number of UE beams to be trained is reported by the UE, e.g., via the "UE beam reciprocity state (update)" message. The BS also indicates whether a fixed UE TX beam or which UE TX beam is used for transmission, or indicates whether different UE TX beams are used for transmission of different resources in a resource set. The BS then feedback measurement results for UE to choose a proper TX beam.

[0011] In one embodiment, a UE obtains resource configuration from a base station in a beamforming communication network. The resource configuration allocates one or more resource sets in time and frequency domain to train a number of UE beams for uplink beam management. The UE obtains beam configuration indicating one or more UE beams to be used for uplink transmission. The UE transmits reference signals over one or more activated resource sets. The UE maps the activated resource set(s) to the one or more UE beams. The UE receives measurement results of the reference signals and thereby determining a proper UE beam for uplink transmission.

[0012] In another embodiment, a BS provides resource configuration to a user equipment (UE) in a beamforming communication network. The resource configuration allocates one or more resource sets in time and frequency domain to train a number of UE beams for uplink beam management. The BS activates one or more resource sets and providing beam configuration with one or more UE beams to be used for uplink transmission. The BS performs measurements on reference signals received from the UE over the activated resource set(s). The BS transmits measurement results to the UE for determining a proper UE beam for uplink transmission.

[0013] Other embodiments and advantages are described in the detailed description below. This summary does not purport to define the invention. The invention is defined by the claims.

BRIEF DESCRIPTION OF DRAWINGS

[0014] The accompanying drawings, where like numerals indicate like components, illustrate
5 embodiments of the invention.

[0015] Figure 1 illustrates a beamforming wireless communication system supporting beam reciprocity reporting and corresponding uplink beam management in accordance with one novel aspect.

[0016] Figure 2 is a simplified block diagram of a base station and a user equipment that carry out
10 certain embodiments of the present invention.

[0017] Figure 3 illustrates definition of beam reciprocity using communication between BS and UE.

[0018] Figure 4 illustrates calibrated RX and TX RF paths and beam reciprocity.

[0019] Figure 5 illustrates a first embodiment of beam reciprocity state indication and update in
15 accordance with a novel aspect.

[0020] Figure 6 illustrates a second embodiment of beam reciprocity state indication and update in accordance with a novel aspect.

[0021] Figure 7 illustrates a third embodiment of beam reciprocity state indication and update in accordance with a novel aspect

[0022] Figure 8 illustrates a beam reciprocity state determination procedure in accordance with
20 one novel aspect.

[0023] Figure 9 is a flow chart of a method of beam reciprocity indication from UE perspective in a beamforming system in accordance with one novel aspect.

[0024] Figure 10 is a flow chart of a method of beam reciprocity indication from BS perspective
25 in a beamforming system in accordance with one novel aspect.

[0025] Figure 11 illustrates an uplink beam management procedure in accordance with one novel aspect.

[0026] Figure 12 illustrates a first example of resource configuration for UL beam management.

[0027] Figure 13 illustrates a second example of resource configuration for UL beam management.

[0028] Figure 14 illustrates a third example of resource configuration for UL beam management.
30

[0029] Figure 15 illustrates embodiments of configuring different sets of resources for UL RS transmission via RRC signaling.

[0030] Figure 16 illustrates embodiments of activating one or subset of the configured resource sets for UL RS transmission via DCI.

[0031] Figure 17 is a flow chart of a method of uplink beam management from UE perspective in a beamforming system in accordance with one novel aspect.

5 [0032] Figure 18 is a flow chart of a method of uplink beam management from base station perspective in a beamforming system in accordance with one novel aspect.

DETAILED DESCRIPTION

[0033] Reference will now be made in detail to some embodiments of the invention, examples of which are illustrated in the accompanying drawings.

10 [0034] Figure 1 illustrates a beamforming wireless communication system 100 supporting beam reciprocity reporting and corresponding uplink beam management in accordance with one novel aspect. Beamforming mmWave mobile communication network 100 comprises a base station BS 101 and a user equipment UE 102. The mmWave cellular network uses directional communications with narrow beams and can support multi-gigabit data rate. Directional communications are achieved via
15 digital and/or analog beamforming, wherein multiple antenna elements are applied with multiple sets of beamforming weights to form multiple beams. In the example of Figure 1, BS 101 is directionally configured with multiple TX/RX BS beams, e.g., #B1, #B2, #B3, #B4, and #B5 to cover a service area. Similarly, UE 102 may also apply beamforming to form multiple UE beams, e.g., #U1 and #U2.

[0035] The set of BS beams may be periodically configured or occur indefinitely and repeatedly in
20 order known to the UEs. Each BS beam broadcasts minimum amount of cell-specific and beam-specific information similar to System Information Block (SIB) or Master Information Block (MIB) in LTE systems. Each BS beam may also carry UE-specific control or data traffic. Each BS beam transmits a set of known reference signals for the purpose of initial time-frequency synchronization, identification of the beam that transmits the signals, and measurement of radio channel quality for the
25 beam that transmits the signals. In one example, a hierarchical control beam and dedicated data beam architecture provides a robust control-signaling scheme to facilitate the beamforming operation in mmWave cellular network systems.

[0036] For beamformed access, both ends of a link need to know which beamformers to use, e.g., a beam pair link (BPL). In downlink DL-based beam management, the BS side provides opportunities
30 for the UE side to measure beamformed channel of different combinations of BS beams and UE beams. For example, BS 101 performs periodic beam sweeping with reference signal (RS) carried on individual BS beams. UE 102 can collect beamformed channel state by using different UE beams,

and UE 102 then report the collect information to BS 101. Beam reciprocity state of UE affects whether additional uplink UL-based beam management is required. UL beam management consumes additional resources heavily and should be minimized. With beam reciprocity or partial beam reciprocity at UE, UL beam management overhead can be reduced.

5 [0037] In according with one novel aspect, UE 102 determines its UE beam reciprocity state and sends a “UE beam reciprocity state” message to BS 101, which triggers proper uplink beam management accordingly. The UE beam reciprocity state message can take place when UE 102 tries to register to the network. For example, this message is transmitted in Radio Resource Control (RRC) signaling. According to factory setting, UE 102 reports at least “Positive” or “Negative” in this message. Beam reciprocity state can be updated by a “UE beam reciprocity state update” message. An auxiliary information can be transmitted to the network for UL beam management if UE reports “Negative” for beam reciprocity state. The auxiliary information indicates the uncertainty level of the UE beams.

10 [0038] For UL beam management, BS 101 configures one or more resource sets to UE 102 for uplink beam management. The one or more resource sets are allocated for UE 102 to transmit UL reference signal using a number of UE beams. The number of UE beams to be trained is reported by UE 102, e.g., via the “UE beam reciprocity state (update)” message with auxiliary information. BS 101 also indicates whether a fixed UE TX beam or which UE TX beam is used for transmission, or indicates whether different UE TX beams are used for transmission of different resources in a resource set. BS 101 then feedback measurement results for UE 102 to choose a proper TX beam.

20 [0039] Figure 2 is a simplified block diagram of a base station and a user equipment that carry out certain embodiments of the present invention. BS 201 has an antenna array 211 having multiple antenna elements that transmits and receives radio signals, one or more RF transceiver modules 212, coupled with the antenna array, receives RF signals from antenna 211, converts them to baseband signal, and sends them to processor 213. RF transceiver 212 also converts received baseband signals from processor 213, converts them to RF signals, and sends out to antenna 211. Processor 213 processes the received baseband signals and invokes different functional modules to perform features in BS 201. Memory 214 stores program instructions and data 215 to control the operations of BS 201. BS 201 also includes multiple function modules and circuits that carry out different tasks in accordance with embodiments of the current invention.

30 [0040] Similarly, UE 202 has an antenna 231, which transmits and receives radio signals. A RF transceiver module 232, coupled with the antenna, receives RF signals from antenna 231, converts them to baseband signals and sends them to processor 233. RF transceiver 232 also converts received baseband signals from processor 233, converts them to RF signals, and sends out to antenna 231.

Processor 233 processes the received baseband signals and invokes different functional modules to perform features in UE 202. Memory 234 stores program instructions and data 235 to control the operations of UE 202. UE 202 also includes multiple function modules and circuits that carry out different tasks in accordance with embodiments of the current invention.

5 [0041] The functional modules and circuits can be implemented and configured by hardware, firmware, software, and any combination thereof. Each module or circuit may comprise a processor with corresponding program codes. For example, BS 201 comprises a beam management module 220, which further comprises a beamforming circuit 221, a beam monitor 222, and a beam resource configuration circuit 223. Beamforming circuit 221 may belong to part of the RF chain, which applies
10 various beamforming weights to multiple antenna elements of antenna 211 and thereby forming various beams. Beam monitor 222 monitors received radio signals and performs measurements of the radio signals over the various beams. Beam resource configuration circuit 223 allocates radio resources and corresponding TX beams to be used for UL beam management.

[0042] Similarly, UE 202 comprises a beam management module 240, which further comprises a
15 beamforming circuit 241, a beam monitor 242, a beam reciprocity reporting module 243, and a beam configuration circuit 244. Beamforming circuit 241 may belong to part of the RF chain, which applies various beamforming weights to multiple antenna elements of antenna 231 and thereby forming various beams. Beam monitor 242 monitors received radio signals and performs measurements of the radio signals over the various beams. Beam reciprocity indication circuit 243 determines UE beam
20 reciprocity and sends out UE beam reciprocity state message to BS 201. Beam configuration circuit 244 receives resource and beam configuration from BS 201, such configuration is based on the received UE beam reciprocity state from UE 201 for uplink beam management to achieve reduced overhead.

UE Beam Reciprocity Indication

25 [0043] Figure 3 illustrates definition of beam reciprocity using communication between BS and UE. It is sometimes assumed that the downlink channel and the uplink channel is spatially reciprocal in the beamforming system. Under spatially reciprocal beamforming, the same beamformed antenna pattern is used for reception and transmission. TX/RX beam reciprocity at BS holds if BS is able to determine a BS Rx beam for the UL reception based on UE's DL measurement on BS's one or more
30 TX beams, and BS is able to determine a BS TX beam for the DL transmission based on BS's UL measurement on BS's one or more RX beams. Similarly, for UE. As illustrated in Figure 3, for downlink transmission, the BS applies TX beamforming vector $\mathbf{V}_{BS,TX}$ and the UE applies RX beamforming vector $\mathbf{V}_{UE,RX}$. For uplink transmission, the BS applies RX beamforming vector $\mathbf{V}_{BS,RX}$ and the UE applies TX beamforming vector $\mathbf{V}_{UE,TX}$. Under spatially reciprocal beamforming, the

beamforming vectors for downlink and uplink are the same, e.g., $(\mathbf{V}_{BS,TX}, \mathbf{V}_{UE,RX}) = (\mathbf{V}_{BS,RX}, \mathbf{V}_{UE,TX})$.

[0044] Figure 4 illustrates calibrated RX and TX RF paths and beam reciprocity. To form desired beam pattern, a relative complex gain between individual RF paths need to be controlled. Individual RF paths are calibrated in phase/magnitude, thus considered coherent. Absolute complex gain is not important for beam pattern. This applies for either TX paths or for RX paths. To claim beam reciprocity, the calibrated complex gain of TX path i (d_{TXi}) and RX path i (d_{RXi}) can be subject to a fixed complex gain. As depicted in Figure 4, beam reciprocity of the illustrated array is maintained under the fixed complex value α , e.g., $d_{TXi} = \alpha d_{RXi}$. Component response of individual RF paths is subject to variation during manufacturing. With factory calibration to assure aligned response, RF component response is also affected by temperature and aging. Partial beam reciprocity is a sensible assumption. RF component variation introduces difference between TX and RX responses. For a coarse beam, beam reciprocity can be treated as hold. For a refined beam, beam reciprocity is not necessarily true. Beam reciprocity state of UE affects whether additional uplink UL-based beam management is required. Furthermore, with partial beam reciprocity at UE, UL beam management overhead can be reduced.

[0045] In accordance with one novel aspect, UE supports a “UE beam reciprocity state” message and a “UE beam reciprocity state update” message to the network in facilitating uplink beam management. The UE beam reciprocity state message can take place when UE tries to register to the network, e.g., this message is transmitted in RRC signaling, or during initial access such as in RACH Msg1 or RACH Msg3. According to factory setting, UE reports at least “Positive” or “Negative” in this message. If UE cannot decide its state, UE reports “Negative”. Optionally, if UE cannot decide its state, UE reports “Unsure”. The indication can be represented by a bit string. For example, all “0” bit string indicates “Negative” state, and all “1” bit string indicates “Positive” state, and other combinations indicate “Unsure” with extra information (e.g., different uncertainty level in terms of beam reciprocity state). The bit length can be dependent on the number of UE analog beam capability, e.g., the largest value of the bit string stands for the number of UE analog beams per antenna panel. There can be another parameter, e.g., a bit string, in capability signaling to represent UE analog beam capability, e.g., the number of UL RS resources needed to train UE beams.

[0046] Beam reciprocity state can be updated by the “UE beam reciprocity state update” message, which can be UE-initiated or network-triggered. The signaling takes place in MAC CE or RRC message, e.g., not part of capability signaling if the state is not static, but part of capability signal if the state is not changed frequently. The signaling can take place during initial access to the network, e.g., in Msg1 or Msg3 in RACH procedure. If beam resolution selected by UE is coarse for the time being, report “Positive” state. If beam resolution selected by UE is fine for the time being, report

“Negative” state. If UE cannot decide its beam reciprocity state, report “Unsure” state. The indication of the “UE beam reciprocity state update” can be represented by a bit string, similar to the “UE beam reciprocity state” message. Note that if there’s no additional “beam reciprocity state update” message, then beam reciprocity state remains unchanged. Furthermore, beam reciprocity state is not updated if it is part of capability signaling.

[0047] Figure 5 illustrates a first embodiment of beam reciprocity state indication and update in accordance with a novel aspect. UE beam reciprocity state is also referred as UE beam correspondence state. In step 511, UE 501 determines UE beam correspondence state. UE 501 can determine its beam reciprocity by different mechanisms. In a first scenario, initial access procedure provides implication of UE beam reciprocity state. For example, if the implication indicates positive state and if following transmissions in CONNECTED mode use same/similar/wider beam resolution as UE beams used during initial access, then the state is positive. On the other hand, if the implication indicates positive state and if following transmissions in CONNECTED mode use narrower (refined) beam resolution as UE beams used during initial access, then the state can be negative. If the implication indicates negative state, then UE reports negative beam reciprocity state. In a second scenario, if UE is capable of beam reciprocity calibration by its own, then periodic triggering of the calibration procedure can ensure positive beam reciprocity state. In a third scenario, If UE is not aware of its current beam reciprocity state, then UE reports either “Negative” state or a “Unsure” state. The “Unsure” state can be represented by, e.g., a series of bits, different bit combinations indicate different uncertainty level in terms of beam reciprocity state. In a fourth scenario, UE can retrieve factory setting for its beam reciprocity state. In step 512, UE 501 transmits the beam reciprocity state message or beam reciprocity state update message to BS 502, which indicates that the UE beam reciprocity state is “Positive”.

[0048] Figure 6 illustrates a second embodiment of beam reciprocity state indication and update in accordance with a novel aspect. UE beam reciprocity state is also referred as UE beam correspondence state. In step 611, UE 601 determines UE beam correspondence state, similar to step 511 of Figure 5. In step 612, UE 601 transmits the beam reciprocity state message or beam reciprocity state update message to BS 602, which indicates that the UE beam reciprocity state is “Negative”. Indication of negative beam reciprocity state may result in UL beam management. UE indicates level of “ambiguity” of its partial beam reciprocity. Along with “Negative” state indication, UE also includes e.g., number of UE beams to examine/sweep. The number of UE beams indicated to BS is preferred to be a subset of all UE beams in the considered resolution. Indication of “Negative” state and the level of ambiguity can be aggregated into a bit string. This facilitates the following resource configuration from the BS for UL beam management resources. In step 613, BS 602 triggers

UL beam management procedure.

[0049] Figure 7 illustrates a third embodiment of beam reciprocity state indication and update in accordance with a novel aspect. UE beam reciprocity state is also referred as UE beam correspondence state. In step 711, UE 701 determines UE beam correspondence state, similar to step 5 511 of Figure 5. In step 712, UE 701 transmits the beam reciprocity state message or beam reciprocity state update message to BS 702, which indicates that the UE beam reciprocity state is “Unsure”. Indication of “Unsure” state may trigger BS to initiate a “beam reciprocity state determination procedure” for determining UE beam reciprocity state. UE indicates level of “ambiguity” of its partial beam reciprocity. Along with “Unsure” state indication, UE also includes 10 e.g., number of UE beams to examine/sweep. The number of UE beams indicated to BS is preferred to be a subset of all UE beams in the considered resolution. Indication of “Unsure” state and the level of ambiguity can be aggregated into a bit string. Indication of “Unsure” state may trigger BS702 to initiate a “beam reciprocity state determination” procedure, as depicted in step 713.

[0050] Figure 8 illustrates a beam reciprocity state determination procedure in accordance with 15 one novel aspect. Partial beam reciprocity implies not all beams of interested beam resolution level need to be examined/swept for a considered terminal or network transmission point. The resource configuration for beam reciprocity state determination procedure considers 1) BS beams need to be examined/swept, and 2) The number of UE beams to be examined/swept (the information is reported by UE). For partial beam reciprocity case, BS beams to be examined is simply a subset of all BS 20 beams of the interested beam resolution level. The subset of BS beams to be examined/swept is constrained by DL beam management results. The subset of BS beams is neighboring beams of selected DL BS beam(s) based on DL beam management with the concerned UE. The size of the subset of BS beams depends on BS side beam reciprocity state, e.g., if BS side beam reciprocity holds and only one DL beam pair is considered, the size can be one and the only beam is the same as the 25 selected DL BS beam.

[0051] In Figure 8 step 811, BS 802 determines resource based on UE reported number of UE beams, BS beam reciprocity, and DL beam pairs to consider. In step 812, BS 802 sends resource configuration to UE 801, which indicates UL resources where UL transmission can take place with the selected number of beams. In step 813, UE 801 performs UL transmission. Individual UE beams 30 may be used for multiple times for transmission. The transmission is received by BS 802 with the subset of BS beams. Individual BS beams may be used for multiple times for reception. In step 821, based on the uplink transmission, BS 802 decides a subset of resources with indices that correspond to stronger received metric. The metric can be but are not limited to, e.g., SNR, SINR, RSRP, etc. The size of the subset of resources depends on, e.g., number of considered DL beam pairs. For example, if

the number of DL beam pair is one, then the size can be one. In step 822, BS 802 signals the determined resource indices with stronger received metric to UE 801.

[0052] In step 831, UE 801 determines its beam reciprocity state, which may involve reciprocity calibration procedure. UE can map the resource indices to corresponding UE beams used for UL transmission. UE can compare the corresponding UE beams with UE beams of considered DL beam pairs. The considered DL beam pairs are determined based on DL beam management procedure. In step 832, UE 801 signals the determined beam reciprocity state to BS 802. If the determined state is “Positive”, such signaling can reuse the “UE beam reciprocity state update” message. If the determined state is “Negative”, and if beam reciprocity calibration is supported, then calibration procedure can be triggered. The calibration procedure intends to change the state to “Positive” and the updated state is reported. Otherwise, “Negative” state signaling can reuse the “UE beam reciprocity state update” message, which triggers UL beam management procedure.

[0053] Figure 9 is a flow chart of a method of beam reciprocity indication from UE perspective in a beamforming system in accordance with one novel aspect. In step 901, a UE obtains a beam reciprocity state in a beamforming communication network. In step 902, the UE provides the beam reciprocity state to a base station. The beam reciprocity state indicates a positive or a negative beam reciprocity. In step 903, the UE performs an uplink beam management procedure when the beam reciprocity state indicates the negative beam reciprocity state. The UE receives resource configuration from the base station and transmits reference signals over the configured resource using corresponding UE beams.

[0054] Figure 10 is a flow chart of a method of beam reciprocity indication from BS perspective in a beamforming system in accordance with one novel aspect. In step 1001, a BS receives a beam reciprocity state from a user equipment (UE) in a beamforming communication network. The beam reciprocity state indicates a positive or a negative UE beam reciprocity state. In step 1002, the BS triggers an uplink beam management procedure when the beam reciprocity state indicates the negative UE beam reciprocity state. The beam management procedure involves configuring resource and receiving reference signals over the configured resource with corresponding UE beams.

Uplink Beam Management

[0055] Figure 11 illustrates an uplink (UL) beam management procedure in accordance with one novel aspect. With partial UE beam reciprocity, uplink UL-based beam management is needed. Partial beam reciprocity implies not all beams of interested beam resolution level are examined/swept for a considered terminal or network transmission point. In UL beam management, the UE side provides opportunities for BS to measure beamformed channel of different combinations of UE beams and BS beams. For example, UE performs periodic beam sweeping with reference signal (RS) carried

on individual UE beams. BS can collect beamformed channel state by using different BS beams, and BS then report the collect information and measurement results to UE such that UE can determine the UL beam pair to be used for UL communication.

[0056] In step 1111, UE 1101 transmits a UE beam reciprocity state = “Negative” message to BS 1102 together with “auxiliary information”. The auxiliary information indicates uncertainty level of UE beams. In one example, it indicates the number of UE beams to be trained in order to select the most proper UL transmit beam. In another example, it indicates the number of UL RS resources that is needed to resolve the uncertainty of UE beams for determining proper UL transmit beam. The auxiliary information can be transmitted together with “UE beam reciprocity state” message or “UE beam reciprocity state update” message. The auxiliary information can be in MAC CE or RRC message. In one example, it can be part of UE capability report. In another example, it can be carried in Msg1 or Msg3 in RACH procedure during initial access to the network. The “negative” state indication and auxiliary information can be represented by a bit string. For example, all “0” bit string indicates “negative” state, and all “1” bit string indicates “positive” state, and other combinations indicate “not sure” with extra information (e.g., different uncertainty level in terms of beam reciprocity state). The bit length can be dependent on the number of UE analog beam capability, e.g., the largest value of the bit string stands for the number of UE analog beam per antenna panel. There can be another parameter e.g., bit string, in capability signal to represent UE analog beam capability, e.g., the number of UL RS resources needed to train UE beams.

[0057] In step 1112, BS 1102 configure several resource sets to UE 1101 for UL reference signal (RS) transmission. The resource configuration for UL beam management considers the following factors: 1) BS beams need to be examined or swept and 2) The number of UE beams to be examined or swept that is reported by UE. For the BS beams, for partial beam reciprocity case, BS beams to be examined is simply a subset of all BS beams of the interested beam resolution level. The size of the subset of BS beams depends on BS side beam reciprocity state. For example, if BS side beam reciprocity holds and only one DL beam pair is considered, the size can be one and the only beam is the same as the selected DL BS beam. The subset of BS beams is constrained by serving BS beam(s) determined from DL beam management results. For the number of UE beams, BS can reuse the content included in “Negative beam reciprocity state update” or in “Unsure beam reciprocity state update”; UE can indicate the number of UE beams in a separate report; or BS acquires the number of UE beams from the “auxiliary information” reported by UE when UE reports “Negative” for UE beam reciprocity state. In step 1113, BS 1102 activates one resource set and configures UE 1101 to train the number of UE beams.

[0058] In step 1121, UE 1101 transmits UL reference signal to BS 1102 over the allocated

resources. The resource configuration can include periodic resources for UE to transmit reference signal with the set of reported ambiguous beams. Additional transmissions can also be configured and triggered aperiodically whenever needed. Individual UE beams may be used for multiple times for transmission in a transmission round. The resource configuration supports a configuration that provides UE to transmit UL reference signal for multiple times by using a same UE beam in a transmission round. The same UE beam can be UE beam used for UL data transmission. The resource configuration supports a configuration that provides UE to transmit UL reference signal for multiple times by using multiple, and optionally different, UE TX beams, respectively in a transmission round. Furthermore, the association of the resources and UE/BS beams can be changed dynamically without additional signaling. BS1102 adapts its receiving beams for UL beam management receptions based on the selected DL BS beam(s) from DL beam management with UE1101. Similarly, UE 1101 adapts its transmitting beams for UL beam management transmissions based on the selected DL BS beam(s) from DL beam management with UE 1101. In step 1122, UE 1101 follows mapping between resource and beam for UL RS transmission. In step 1123, BS 1102 selects its RX beam that is transparent to UE. Finally, in step 1131, BS 1102 feedback UL RS measurement result to UE 1101 for determining the proper UE TX beam.

[0059] Figure 12 illustrates a first example of resource configuration for UL beam management. According to UE capability, network can configure more than one resource per time unit. The use of UE beam on a specific resource can be selected by UE. In the example of Figure 12, in time unit #1, network configures resources #1 and #2 for UE beams #1 and #2, respectively. In time unit #2, network configures resources #3 and #4 for UE beams #3 and #4, respectively. In time unit #3, network configures resources #5 and #6 for UE beams #5 and #6, respectively. In time unit #4, network configures resources #7 and #8 for UE beams #7 and #8, respectively.

[0060] Figure 13 illustrates a second example of resource configuration for UL beam management. Network can configure multiple resources in multiple time units with different UE beams. In the example of Figure 13, network configures resource #1 for UE beam #1 in time unit #1, resource #2 for UE beam #2 in time unit #2, resource #3 for UE beam #3 in time unit #3, and resource #4 for UE beam #4 in time unit #4.

[0061] Figure 14 illustrates a third example of resource configuration for UL beam management. Network can configure multiple resources in multiple time units with the same UE beam. In the example of Figure 14, network configures resource #1 for UE beam #1 in time unit #1, resource #2 for UE beam #1 in time unit #2, resource #3 for UE beam #2 in time unit #3, and resource #4 for UE beam #2 in time unit #4.

[0062] When the network configures resources for UE to transmit uplink reference signal (UL

RS), the network can indicate one or more sets of resources in time and frequency domain (and optionally antenna port). The configuration of the sets of resources can be via RRC signaling. The activation of one or a subset of the resource sets can be via physical layer control channel, e.g., downlink control information (DCI) carried in physical downlink control channel (PDCCH). The number of resources in a resource set is dependent on the number of UE TX beams to be used for UL RS transmission. Further, the network can indicate whether a fixed UE TX beam is used for transmission or not, which of the UE TX beams is used as the fixed UE TX beam, or whether different UE TX beams are used for transmission of different resources in a resource set.

[0063] In one embodiment, the network indicates whether a fixed UE TX beam is used for transmission or not. The use of fixed UE TX beam can be indicated together with the resource configuration i.e., via RRC signaling. The use of fixed UE TX beam can be indicated in DCI that is used for triggering UL RS transmission. The indication can be implicit, e.g., when it is not explicitly indicated otherwise, a fixed TX beam is required. Optionally, which of UE TX beams is used as the fixed UE TX beam can be indicated. The indication can be via MAC CE signaling, or in DCI that is used for triggering UL RS transmission. The indication can refer to the UE TX beam that is used for previous UL RS transmission resources. The indication can be via spatial QCL information or can be via beam pair link tag that is associated with UE TX beam for UL traffic. If there is no such indication, it is up to UE decision, when the network demands to use a fixed beam.

[0064] In another embodiment, the number of resources in a resource set is dependent on the number of UE TX beams to be used for UL RS transmission. The number of UE TX beams can be decided by the network based on, e.g., the auxiliary information provided by UE. Optionally, the network indicates whether different UE TX beams are used for transmission of different resources, respectively, in a resource set. The use of different UE TX beams can be indicated together with the resource configuration i.e., via RRC signaling. The use of different UE TX beams can be indicated in DCI that is used for triggering UL RS transmission. The indication can be implicit, e.g., when it is not explicitly indicated otherwise, different TX beams are used.

[0065] Figure 15 illustrates embodiments of configuring different sets of resources for UL RS transmission via RRC signaling. As depicted in Figure 15, the configuration for a first resource set #1 indicates the resource location indices, and the use of a fixed UE TX beam for UL RS transmission. The configuration for a first resource set #2 indicates the resource location indices, and the use of different UE TX beams for UL RS transmission. The configuration for a first resource set #3 indicates the resource location indices.

[0066] Figure 16 illustrates embodiments of activating one or subset of the configured resource sets for UL RS transmission via DCI. As depicted in Figure 16, DCI#1 triggers UL RS transmission

using resource set #1 using the same UE beam, e.g., UL RS transmission using resource #1 with UE reference beam #1 at time unit #1, UL RS transmission using resource #2 with UE reference beam #1 at time unit #2, and UL RS transmission using resource #3 with UE reference beam #1 at time unit #3. DCI #2 triggers UL RS transmission using resource set #2 using different UE beams, e.g., UL RS transmission using resource #1 with UE reference beam #2 at time unit #1, UL RS transmission using resource #2 with UE reference beam #3 at time unit #2, and UL RS transmission using resource #3 with UE reference beam #5 at time unit #3. DCI #3 triggers UL RS transmission using resource set #3 without UE beam indication so UE determines different beams for different resources itself, e.g., UL RS transmission using resource #1 with UE reference beam #2 at time unit #1, UL RS transmission using resource #2 with UE reference beam #3 at time unit #2, and UL RS transmission using resource #3 with UE reference beam #5 at time unit #3.

[0067] Figure 17 is a flow chart of a method of uplink beam management from UE perspective in a beamforming system in accordance with one novel aspect. In step 1701, a UE obtains resource configuration from a base station in a beamforming communication network. The resource configuration allocates one or more resource sets in time and frequency domain to train a number of UE beams for uplink beam management. In step 1702, the UE obtains beam configuration indicating one or more UE beams to be used for uplink transmission. In step 1703, the UE transmits reference signals over one or more activated resource sets. The UE maps the activated resource set(s) to the one or more UE beams. In step 1704, the UE receives measurement results of the reference signals and thereby determining a proper UE beam for uplink transmission.

[0068] Figure 18 is a flow chart of a method of uplink beam management from base station perspective in a beamforming system in accordance with one novel aspect. In step 1801, the BS providing resource configuration to a user equipment (UE) in a beamforming communication network. The resource configuration allocates one or more resource sets in time and frequency domain to train a number of UE beams for uplink beam management. In step 1802, the BS activates one or more resource sets and providing beam configuration with one or more UE beams to be used for uplink transmission. In step 1803, the BS performs measurements on reference signals received from the UE over the activated resource set(s). In step 1804, the BS transmits measurement results to the UE for determining a proper UE beam for uplink transmission.

[0069] Although the present invention has been described in connection with certain specific embodiments for instructional purposes, the present invention is not limited thereto. Accordingly, various modifications, adaptations, and combinations of various features of the described embodiments can be practiced without departing from the scope of the invention as set forth in the claims.

CLAIMS

1. A method comprising:

obtaining resource configuration from a base station by a user equipment (UE) in a beamforming
5 communication network, wherein the resource configuration allocates one or more resource sets in
time and frequency domain to train a number of UE beams for uplink beam management;

obtaining beam configuration indicating one or more UE beams to be used for uplink
transmission;

transmitting reference signals over one or more activated resource sets, wherein the UE maps the
10 one or more activated resource sets to the one or more UE beams; and

receiving measurement results of the reference signals from the base station and thereby
determining a proper UE beam for uplink transmission.

2. The method of Claim 1, wherein the UE transmits the reference signals for multiple times by
using a same UE beam in a transmission round.

15 3. The method of Claim 1, wherein the UE transmits the reference signals for multiple times by
using different UE beams in a transmission round.

4. The method of Claim 1, wherein the UE dynamically associates the one or more resource sets
with the number of UE beams.

5. The method of Claim 1, further comprising:

20 transmitting a UE beam reciprocity state to the base station indicating negative UE beam
reciprocity.

6. The method of Claim 5, wherein the UE further transmits auxiliary information along with the
UE beam reciprocity state.

7. The method of Claim 6, wherein the auxiliary information indicates the number of UE beams
25 to be trained for uplink beam management.

8. A User Equipment (UE) comprising:

a resource configuration circuit that obtains resource configuration from a base station in a
beamforming communication network, wherein the resource configuration allocates one or more
resource sets in time and frequency domain to train a number of UE beams for uplink beam
30 management;

a beam configuration circuit that obtains beam configuration indicating one or more UE beams to
be used for uplink transmission;

a radio frequency (RF) transmitter that transmits reference signals over one or more activated

resource sets, wherein the UE maps the one or more activated resource sets to the one or more UE beams; and

an RF receiver that receives measurement results of the reference signals from the base station and thereby determining a proper UE beam for uplink transmission.

5 9. The UE of Claim 8, wherein the UE transmits the reference signals for multiple times by using a same UE beam in a transmission round.

10. The UE of Claim 8, wherein the UE transmits the reference signals for multiple times by using different UE beams in a transmission round.

10 11. The UE of Claim 8, wherein the UE dynamically associates the one or more resource sets with the number of UE beams.

12. The UE of Claim 8, wherein the UE transmits a UE beam reciprocity state to the base station indicating negative UE beam reciprocity.

13. The UE of Claim 12, wherein the UE further transmits auxiliary information along with the UE beam reciprocity state.

15 14. The UE of Claim 13, wherein the auxiliary information indicates the number of UE beams to be trained for uplink beam management.

15. A method comprising:

20 providing resource configuration to a user equipment (UE) by a base station in a beamforming communication network, wherein the resource configuration allocates one or more resource sets in time and frequency domain to train a number of UE beams for uplink beam management;

activating one or more resource sets and providing beam configuration with one or more UE beams to be used for uplink transmission;

performing measurements on reference signals received from the UE over the one or more activated resource sets; and

25 transmitting measurement results of the reference signals to the UE for determining a proper UE beam for uplink transmission.

16. The method of Claim 15, wherein the base station configures the UE to transmit the reference signals for multiple times by using a same UE beam in a transmission round.

30 17. The method of Claim 15, wherein the base station configures the UE to transmit the reference signals for multiple times by using different UE beams in a transmission round.

18. The method of Claim 15, wherein the base station provides the resource configuration via a radio resource control (RRC) layer signaling, and wherein the base station activates the resource set via a physical layer control channel.

19. The method of Claim 15, further comprising:

receiving a UE beam reciprocity state from the UE indicating negative UE beam reciprocity.

20. The method of Claim 18, wherein the base station also receives auxiliary information along with the UE beam reciprocity state.

21. The method of Claim 19, wherein the auxiliary information indicates the number of UE
5 beams to be trained for uplink management.

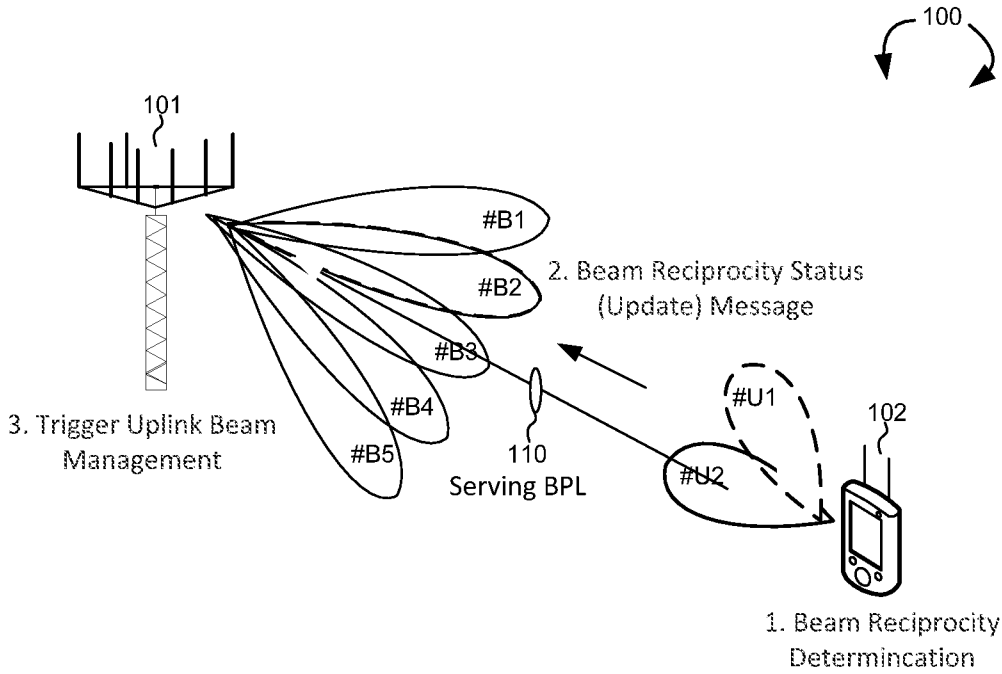

FIG. 1

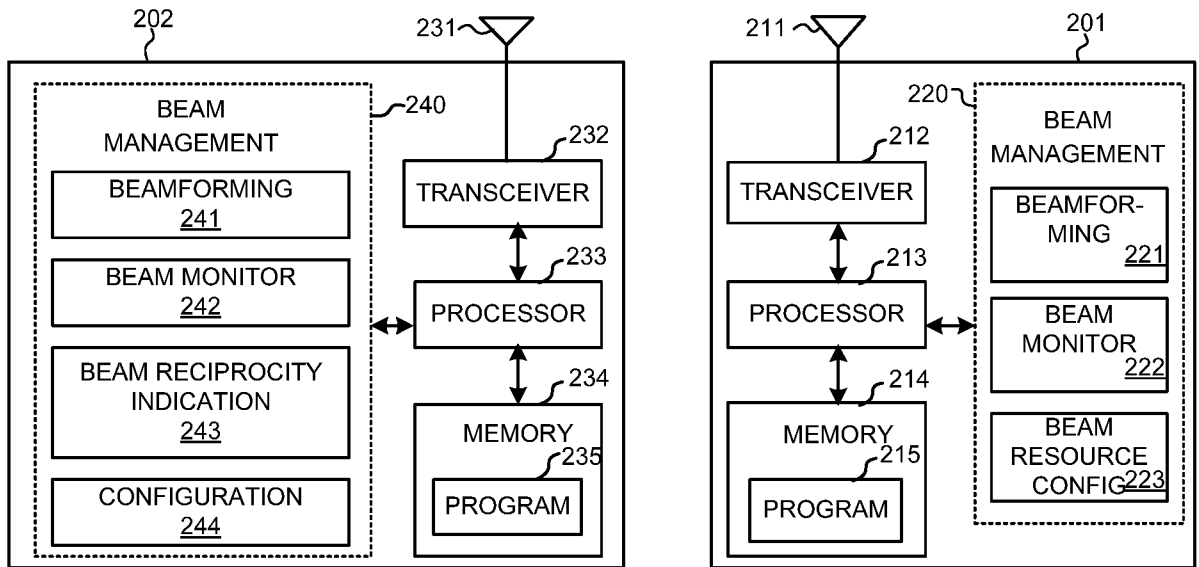

FIG. 2

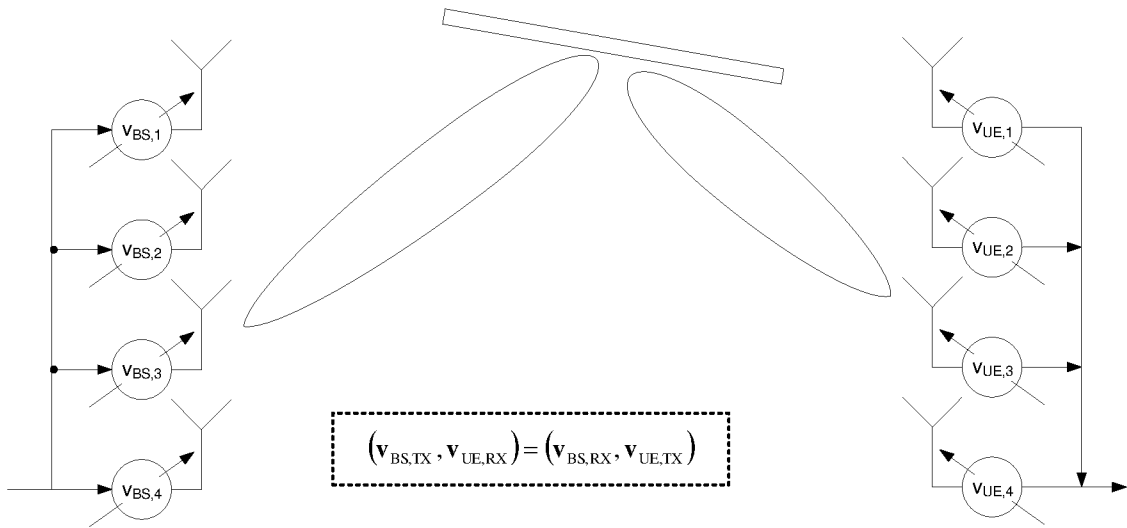

FIG. 3

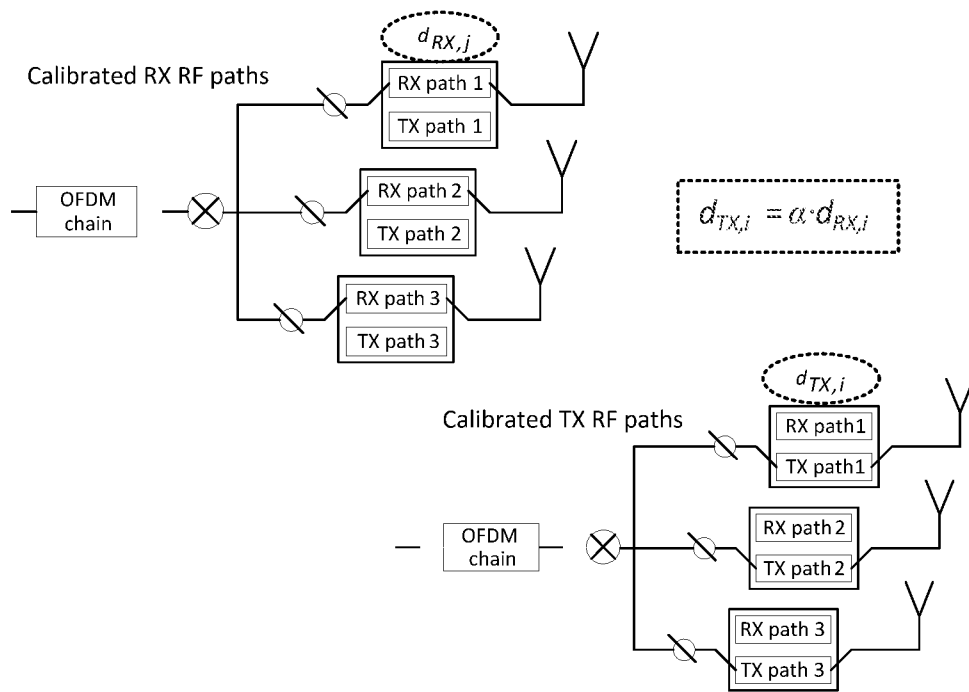

FIG. 4

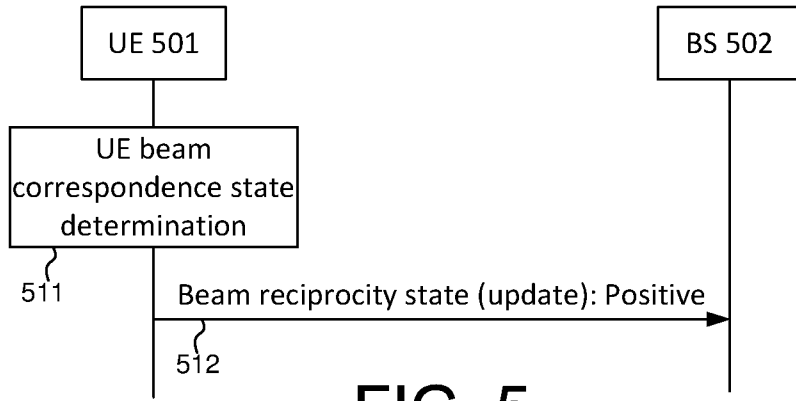

FIG. 5

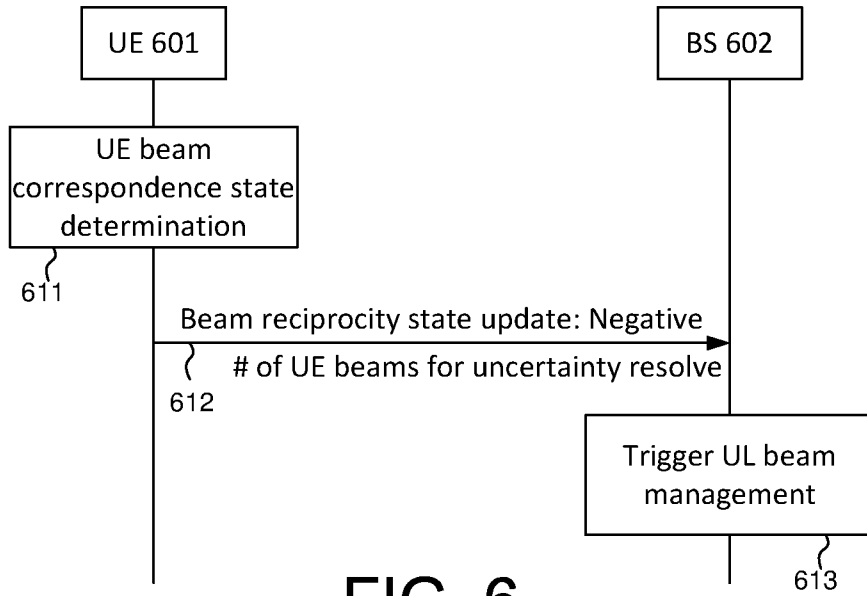

FIG. 6

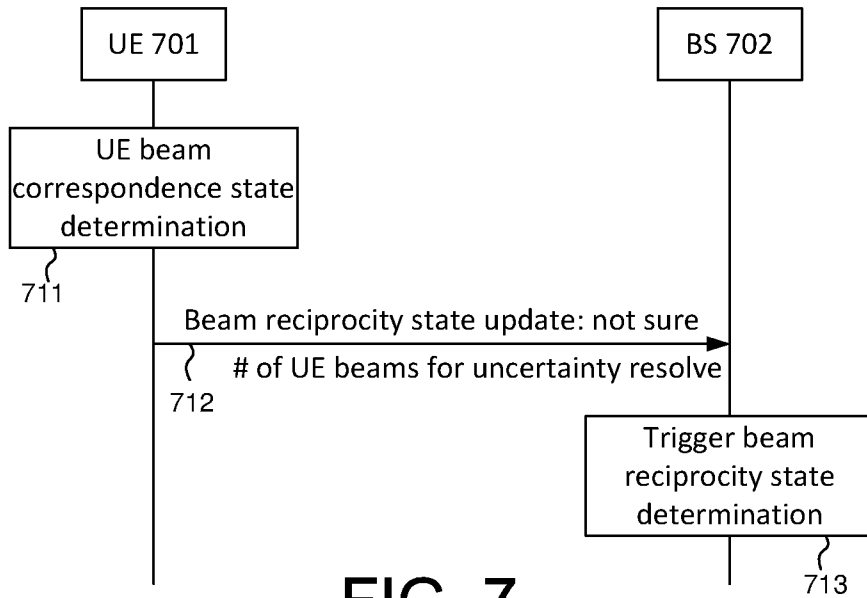

FIG. 7

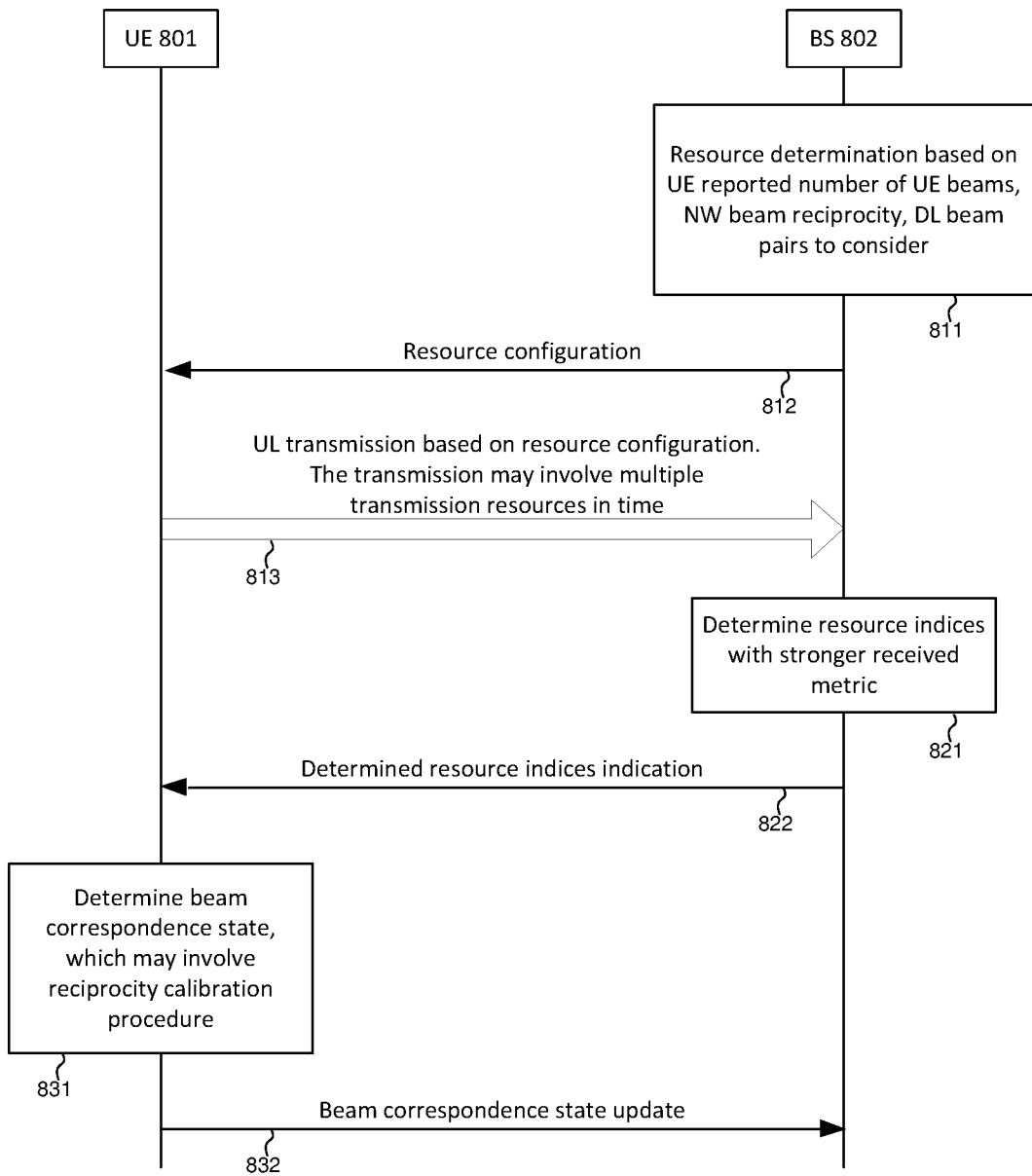

FIG. 8

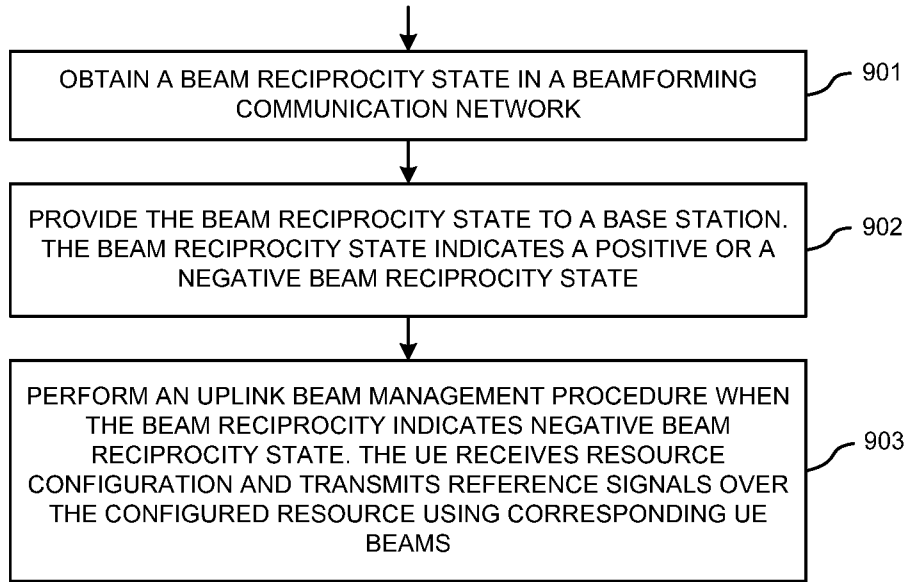

FIG. 9

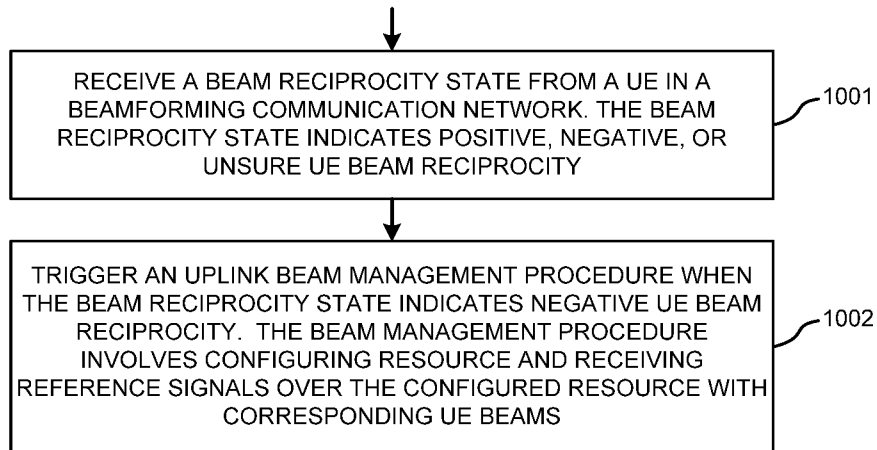

FIG. 10

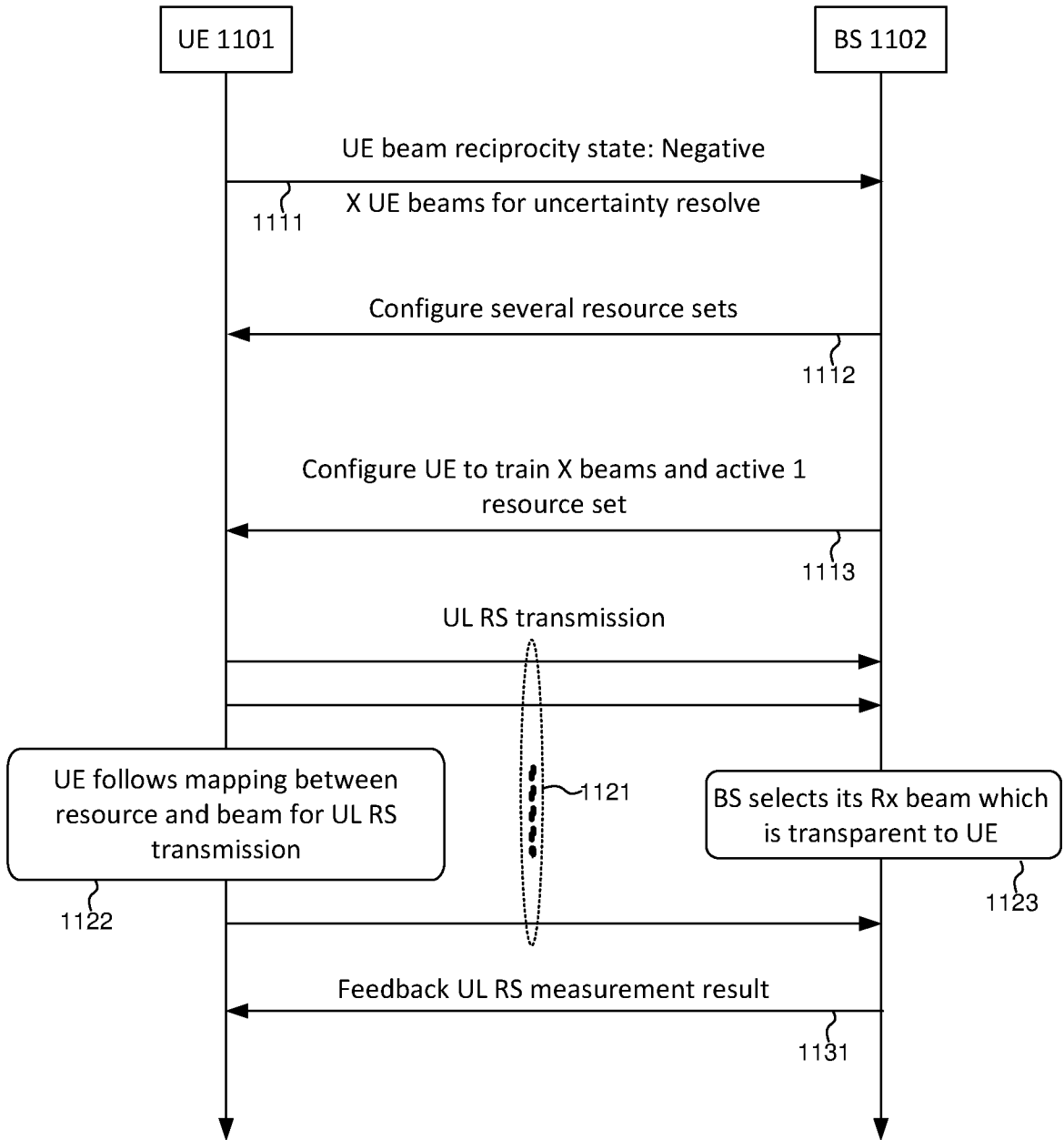

FIG. 11

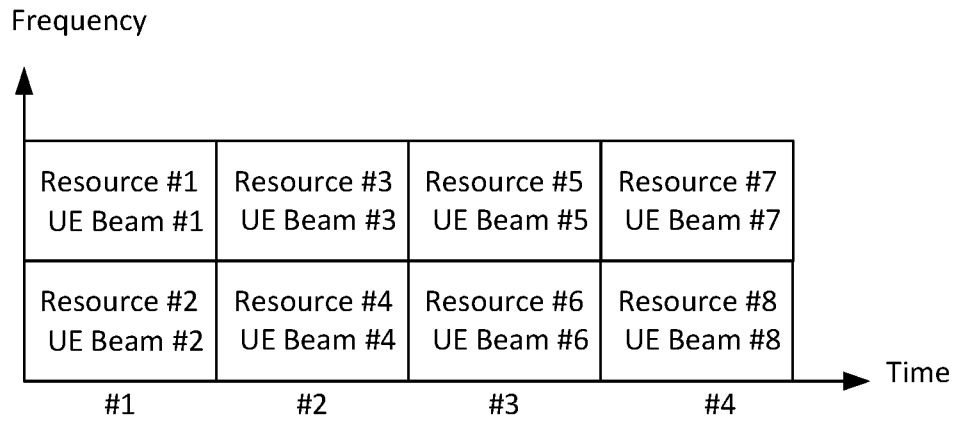

FIG. 12

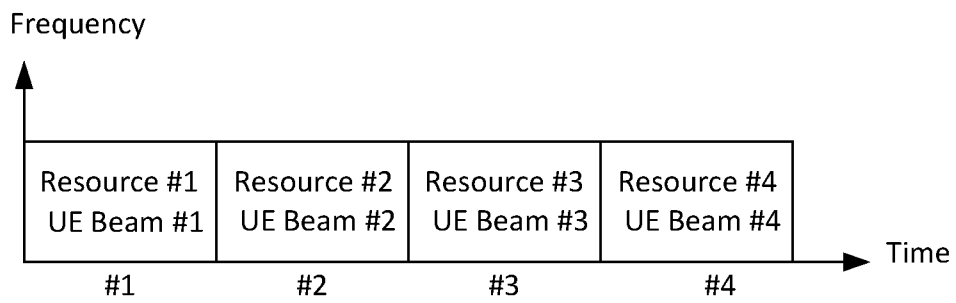

FIG. 13

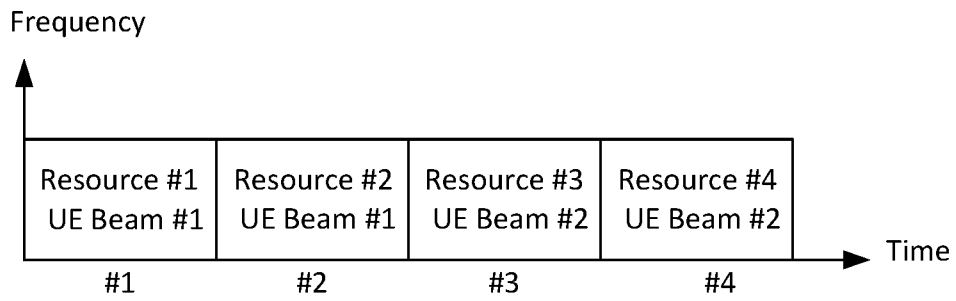

FIG. 14

UL RS configuration	
Set #1	<ul style="list-style-type: none"> Resource location indices Same UE beam
Set #2	<ul style="list-style-type: none"> Resource location indices Different UE beams

UL RS configuration	
Set #3	<ul style="list-style-type: none"> Resource location indices

FIG. 15

DCI #1

- Trigger set #1
- Use beam ref. #1

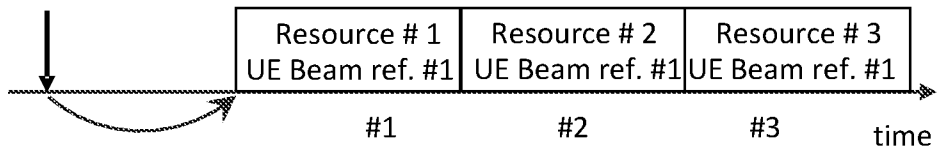

DCI #2

- Trigger set #2

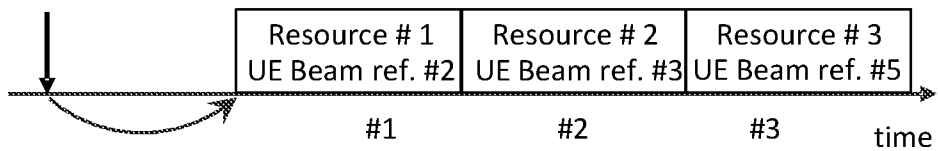

DCI #3

- Trigger set #3
- Use different UE Tx beams

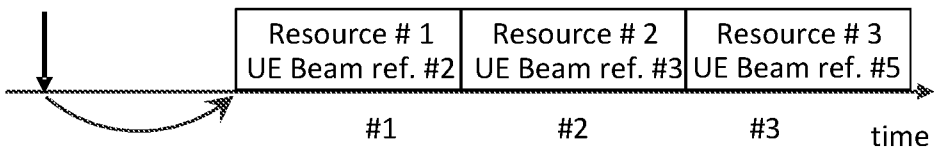

FIG. 16

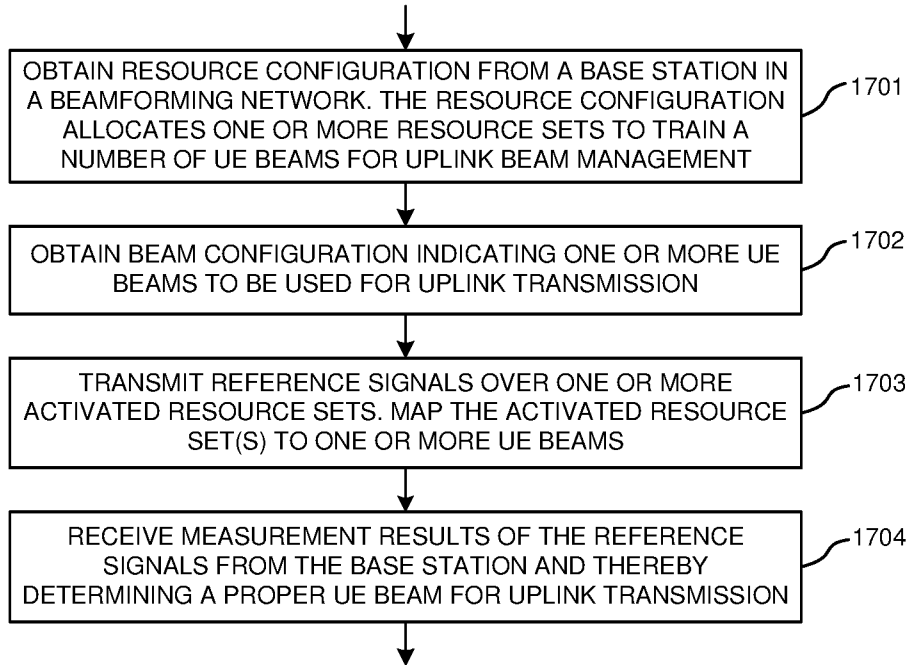

FIG. 17

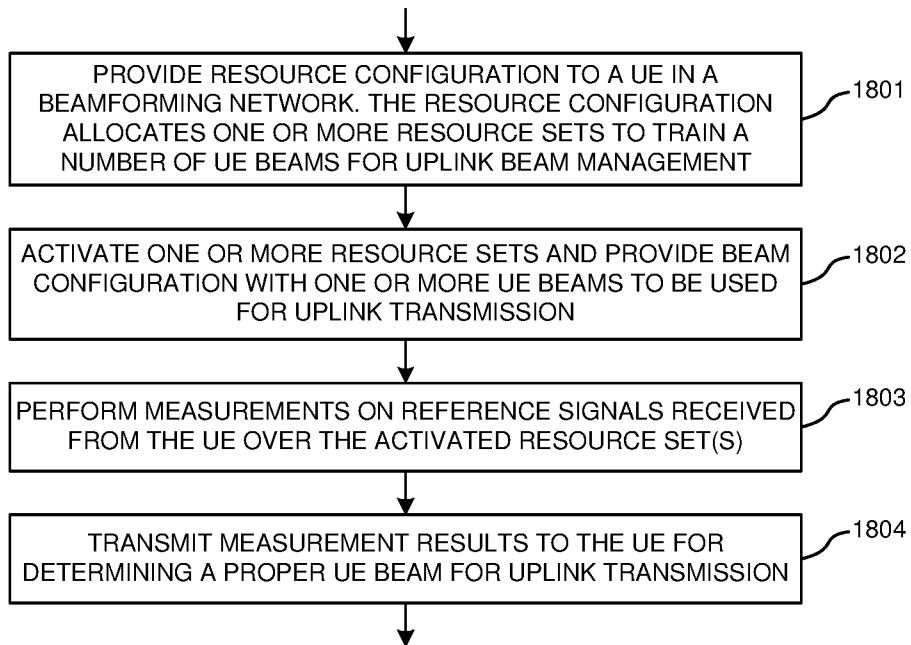

FIG. 18

INTERNATIONAL SEARCH REPORT

International application No.

PCT/CN2018/075380

A. CLASSIFICATION OF SUBJECT MATTER		
H04B 7/04(2017.01)i		
According to International Patent Classification (IPC) or to both national classification and IPC		
B. FIELDS SEARCHED		
Minimum documentation searched (classification system followed by classification symbols)		
H04B7/-;H04W36/-;		
Documentation searched other than minimum documentation to the extent that such documents are included in the fields searched		
Electronic data base consulted during the international search (name of data base and, where practicable, search terms used)		
CNABS,CNTXT,CNKI,VEN:uplink,management,configuration,beam,beamforming,resource,set		
C. DOCUMENTS CONSIDERED TO BE RELEVANT		
Category*	Citation of document, with indication, where appropriate, of the relevant passages	Relevant to claim No.
X	CN 105103261 A (SAMSUNG ELECTRONICS CO., LTD) 25 November 2015 (2015-11-25) claims 7 and 9, description paragraph [0050] to paragraph [0129], figure 4	1-4, 8-11, 15-18
A	CN 105830496 A (MEDIATEK INC.) 03 August 2016 (2016-08-03) the whole document	1-21
A	US 2015146484 A1 (SAMSUNG ELECTRONICS CO., LTD) 28 May 2015 (2015-05-28) the whole document	1-21
<input type="checkbox"/> Further documents are listed in the continuation of Box C. <input checked="" type="checkbox"/> See patent family annex.		
* Special categories of cited documents: "A" document defining the general state of the art which is not considered to be of particular relevance "E" earlier application or patent but published on or after the international filing date "L" document which may throw doubts on priority claim(s) or which is cited to establish the publication date of another citation or other special reason (as specified) "O" document referring to an oral disclosure, use, exhibition or other means "P" document published prior to the international filing date but later than the priority date claimed "T" later document published after the international filing date or priority date and not in conflict with the application but cited to understand the principle or theory underlying the invention "X" document of particular relevance; the claimed invention cannot be considered novel or cannot be considered to involve an inventive step when the document is taken alone "Y" document of particular relevance; the claimed invention cannot be considered to involve an inventive step when the document is combined with one or more other such documents, such combination being obvious to a person skilled in the art "&" document member of the same patent family		
Date of the actual completion of the international search		Date of mailing of the international search report
20 April 2018		03 May 2018
Name and mailing address of the ISA/CN		Authorized officer
STATE INTELLECTUAL PROPERTY OFFICE OF THE P.R.CHINA 6, Xitucheng Rd., Jimen Bridge, Haidian District, Beijing 100088 China		YAN, Yan
Facsimile No. (86-10)62019451		Telephone No. 62411411

INTERNATIONAL SEARCH REPORT
Information on patent family members

International application No.

PCT/CN2018/075380

Patent document cited in search report			Publication date (day/month/year)	Patent family member(s)			Publication date (day/month/year)				
CN	105103261	A	25 November 2015	US	2014241242	A1	28 August 2014				
				CN	105103261	B	16 February 2018				
				KR	20140107117	A	04 September 2014				
				JP	2016514406	A	19 May 2016				
				US	9392639	B2	12 July 2016				
				WO	2014133311	A1	04 September 2014				
				EP	2962321	A1	06 January 2016				
				EP	2962321	A4	01 February 2017				
				IN	201502919	P2	24 June 2016				
				CN	105830496	A	03 August 2016	EP	3195493	A1	26 July 2017
EP	3175646	A4	28 February 2018								
EP	3195493	A4	20 December 2017								
WO	2016045528	A1	31 March 2016								
CN	106464312	A	22 February 2017								
WO	2016045529	A1	31 March 2016								
US	9698884	B2	04 July 2017								
EP	3175646	A1	07 June 2017								
US	2016087704	A1	24 March 2016								
US	2016087705	A1	24 March 2016								
IN	201727005383	A	24 March 2017								
US	2015146484	A1	28 May 2015					KR	20150061098	A	04 June 2015