

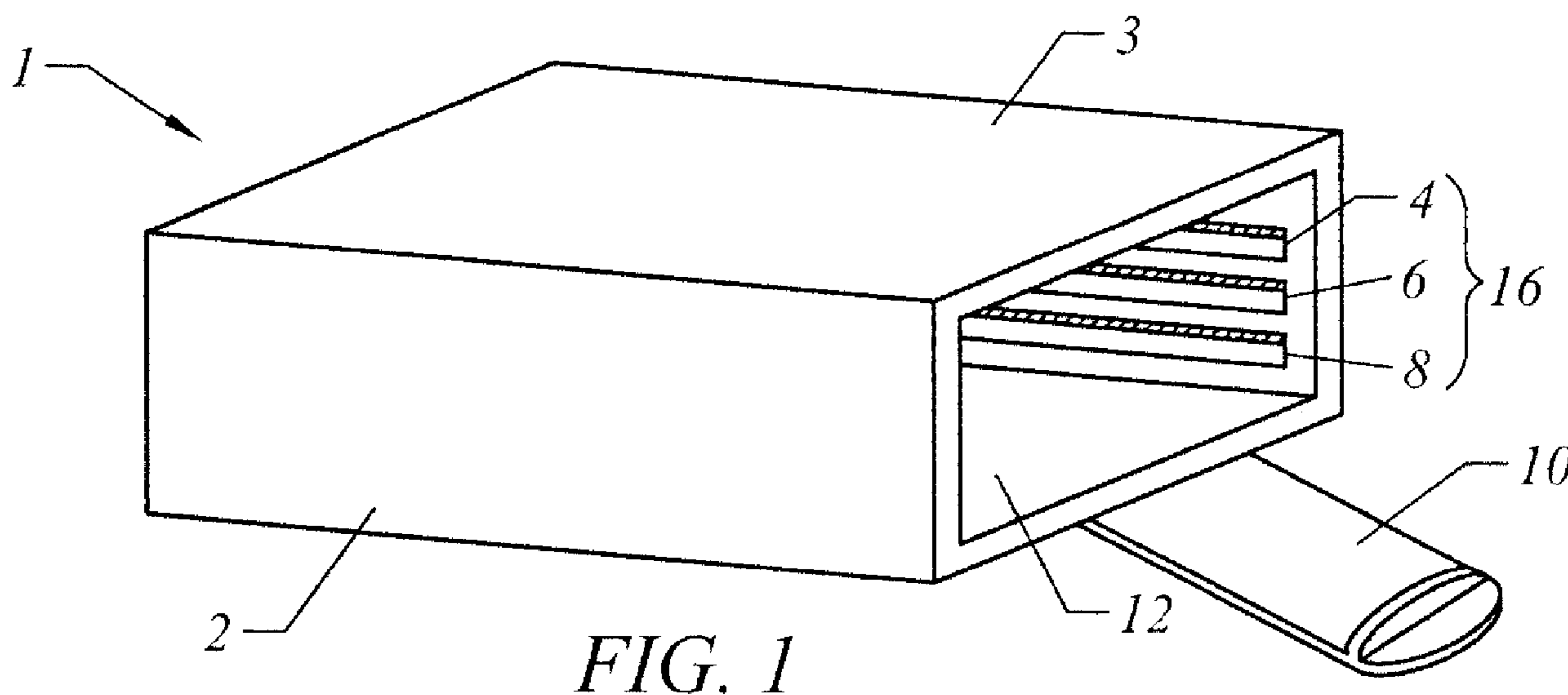

(86) Date de dépôt PCT/PCT Filing Date: 2008/07/30  
 (87) Date publication PCT/PCT Publication Date: 2009/02/05  
 (85) Entrée phase nationale/National Entry: 2010/02/01  
 (86) N° demande PCT/PCT Application No.: US 2008/071563  
 (87) N° publication PCT/PCT Publication No.: 2009/018324  
 (30) Priorité/Priority: 2007/07/31 (US60/962,602)

(51) Cl.Int./Int.Cl. *B65D 85/48* (2006.01),  
*B65D 85/30* (2006.01)  
 (71) Demandeur/Applicant:  
GENOPTIX, INC., US  
 (72) Inventeur/Inventor:  
LAIPPLY, THOMAS C., US  
 (74) Agent: SMART & BIGGAR

(54) Titre : CONTENANT DE LAMELLE DE MICROSCOPE  
 (54) Title: MICROSCOPE SLIDE CONTAINER



(57) **Abrégé/Abstract:**

The invention provides a container for the storage and transport of microscope slides. In particular, the container comprises one or more receiving means for receiving a plurality of microscope slides such that both surfaces of each slide are exposed to air and at least one side of the container is fully open. The container may also comprise a closing means capable of preventing microscope slides contained inside the container from sliding out of the container. The design of the container allows for air exchange between the outside and inside of the container to facilitate the drying of slides contained within the container. Methods of transporting and drying microscope slides are also disclosed.

(12) INTERNATIONAL APPLICATION PUBLISHED UNDER THE PATENT COOPERATION TREATY (PCT)

(19) World Intellectual Property Organization  
International Bureau(43) International Publication Date  
5 February 2009 (05.02.2009)

PCT

(10) International Publication Number  
**WO 2009/018324 A1**(51) International Patent Classification:  
*B65D 85/48* (2006.01)(21) International Application Number:  
PCT/US2008/071563

(22) International Filing Date: 30 July 2008 (30.07.2008)

(25) Filing Language: English

(26) Publication Language: English

(30) Priority Data:  
60/962,602 31 July 2007 (31.07.2007) US(71) Applicant (for all designated States except US): **GENOPTIX, INC.** [US/US]; 2110 Rutherford Road, Carlsbad, CA 92008 (US).

(72) Inventor; and

(75) Inventor/Applicant (for US only): **LAIPPLY, Thomas, C.** [US/US]; 2340 Zodiac Street, Carlsbad, CA 92009 (US).(74) Agents: **PURCELL, Angela** et al.; Cooley Godward Kronish LLO, 777 6th Street, N.W., Suite 1100, Washington, DC 20001 (US).

(81) Designated States (unless otherwise indicated, for every kind of national protection available): AE, AG, AL, AM, AO, AT, AU, AZ, BA, BB, BG, BH, BR, BW, BY, BZ, CA, CH, CN, CO, CR, CU, CZ, DE, DK, DM, DO, DZ, EC, EE, EG, ES, FI, GB, GD, GE, GH, GM, GT, HN, HR, HU, ID, IL, IN, IS, JP, KE, KG, KM, KN, KP, KR, KZ, LA, LC, LK, LR, LS, LT, LU, LY, MA, MD, ME, MG, MK, MN, MW, MX, MY, MZ, NA, NG, NI, NO, NZ, OM, PG, PH, PL, PT, RO, RS, RU, SC, SD, SE, SG, SK, SL, SM, ST, SV, SY, TJ, TM, TN, TR, TT, TZ, UA, UG, US, UZ, VC, VN, ZA, ZM, ZW.

(84) Designated States (unless otherwise indicated, for every kind of regional protection available): ARIPO (BW, GH, GM, KE, LS, MW, MZ, NA, SD, SL, SZ, TZ, UG, ZM, ZW), Eurasian (AM, AZ, BY, KG, KZ, MD, RU, TJ, TM), European (AT, BE, BG, CH, CY, CZ, DE, DK, EE, ES, FI, FR, GB, GR, HR, HU, IE, IS, IT, LT, LU, LV, MC, MT, NL, NO, PL, PT, RO, SE, SI, SK, TR), OAPI (BF, BJ, CF, CG, CI, CM, GA, GN, GQ, GW, ML, MR, NE, SN, TD, TG).

**Published:**

— with international search report

(54) Title: MICROSCOPE SLIDE CONTAINER

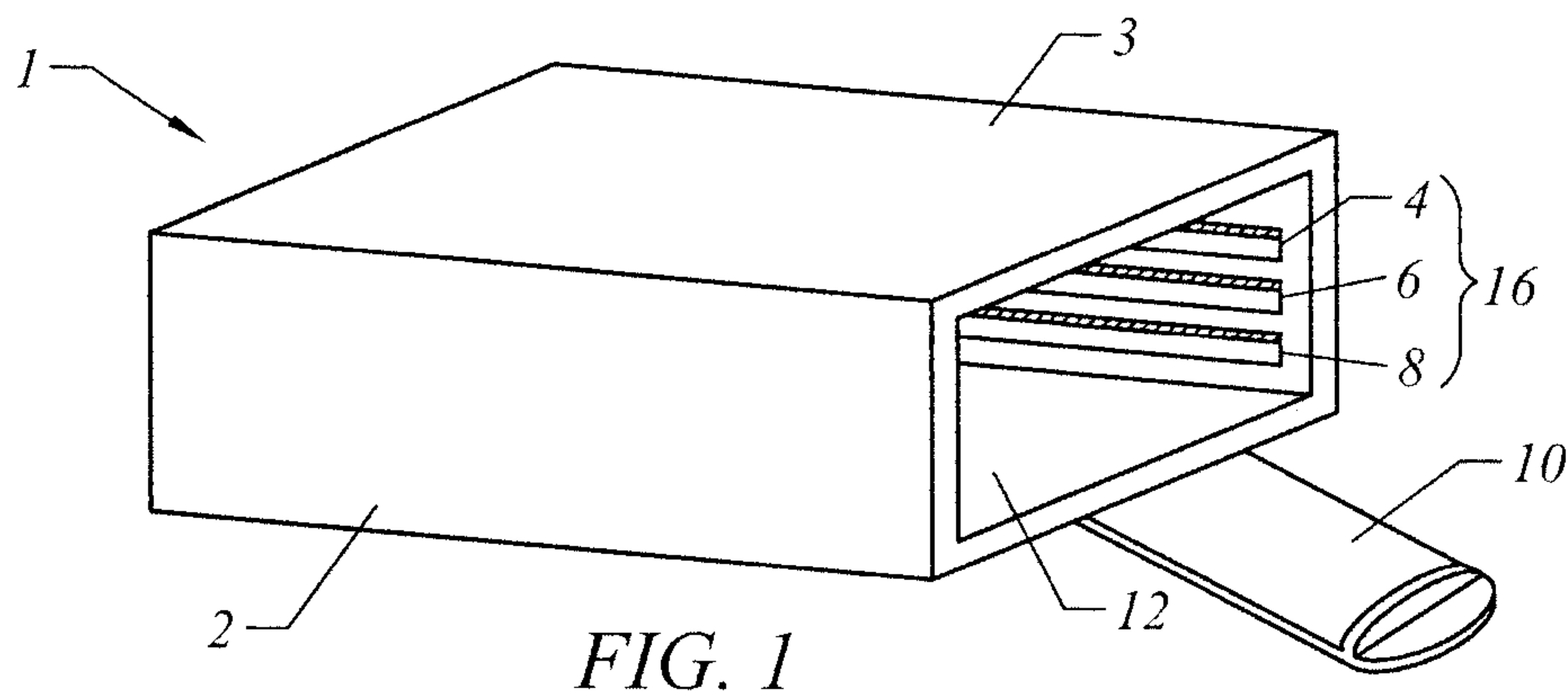

FIG. 1

(57) Abstract: The invention provides a container for the storage and transport of microscope slides. In particular, the container comprises one or more receiving means for receiving a plurality of microscope slides such that both surfaces of each slide are exposed to air and at least one side of the container is fully open. The container may also comprise a closing means capable of preventing microscope slides contained inside the container from sliding out of the container. The design of the container allows for air exchange between the outside and inside of the container to facilitate the drying of slides contained within the container. Methods of transporting and drying microscope slides are also disclosed.

WO 2009/018324 A1

## MICROSCOPE SLIDE CONTAINER

### CROSS-REFERENCE TO RELATED APPLICATIONS

[0001] This application claims priority to U.S. Provisional Application No. 60/962,602 filed July 31, 2007, which is herein incorporated by reference in its entirety.

### FIELD OF THE INVENTION

[0002] The invention relates to a container for transporting and storing microscope slides. In particular, the container is designed such that air passes into the container from the external environment and circulates freely within the container. Such a design allows for microscope slides to be dried while transported in the container.

### BACKGROUND OF THE INVENTION

[0003] Microscope slides are typically rectangular, thin pieces of glass on which biological specimens, such as tissue, cells, and fluids are adhered or smeared. Because microscope slides are relatively fragile, devices that securely hold the slides and protect the specimens that may be deposited on them during transport and storage are required.

[0004] Diagnosis of many hematologic diseases relies on the examination of microscope slides containing blood or tissues samples from a patient. Cellular material from peripheral blood, bone marrow, or other tissues is smeared or spread on the surface of a microscope slide for subsequent staining and microscopic evaluation. The integrity of the sample is critical for adequate staining and accurate interpretation of test results. The preservation of the sample is highly dependent on whether the sample is thoroughly air-dried. Air drying is a form of cell fixation, which acts to maintain the structure of cells and biological materials contained within the sample.

[0005] A common problem in the storage and transport of slides containing biological specimens, particularly hematological samples, is that the slides are placed in containers before they have completely dried, which results in the degeneration and destruction of the cellular material in the sample before the slides have been stained or processed. Such samples are of limited or no value for use in the diagnosis of diseases or disorders. Thus, a container which allows for the exchange of air between the inside and outside of the container to facilitate thorough air drying of samples present on microscope slides placed in such a container is desirable.

#### SUMMARY OF THE INVENTION

[0006] One object of the present invention is to provide a container for storing and transporting a plurality of microscope slides, in which sufficient air circulation is present to facilitate the drying of slides placed inside the container. Accordingly, in one embodiment of the invention, the container comprises one or more receiving means, wherein each receiving means is structured to receive a microscope slide with both sides of the slide exposed to air, and wherein at least one side of the container is fully open. Such a container is simple and allows for slides to be easily inserted and removed without disrupting samples deposited on the slides. In some embodiments, the microscope slides are hematological slides.

[0007] Each receiving means of the container comprises a first holding means and a second holding means, wherein the first holding means is on a first side of the container and the second holding means is on a second side of the container. The distance between the first holding means and the second holding means may be equal to the width of a microscope slide.

[0008] In another embodiment of the invention, the container having a third side fully open may comprise a closing means capable of partially closing the third side of the container when it is in a closed position and preventing microscope slides contained inside the container from sliding out of the container. The closing means can be fixed to the third side of the container or be removable from the container.

[0009] In another embodiment, the container may have a fourth side that is partially open. The fourth side may comprise one or more slits or openings that enhance air flow into the container. The fourth side may comprise a mesh structure that partially covers the open side. The mesh structure keeps the slides from sliding out of the container as well as enhancing air exchange between the inside and outside of the container.

[0010] The present invention also provides a method of transporting a microscope slide. In one embodiment, the method comprises placing the microscope slide in the receiving means of the container, and during transportation of the container partially closing the side that is fully open with a closing means to prevent the microscope slide from sliding out of the container. The closing means may be removed when the container is not in transit to allow for one side of the container to be fully open.

[0011] The present invention also contemplates a method of drying a microscope slide. In one embodiment, the method comprises placing the microscope slide in the receiving means of the container. Preferably, the microscope slide is dried during transportation of the container.

#### BRIEF DESCRIPTION OF THE DRAWINGS

[0012] **FIG. 1** is a perspective view of the microscope slide container according to a first embodiment of the invention.

[0013] **FIG. 2** is a horizontal cross-section of the container shown in FIG. 1.

[0014] **FIG. 3** is a side view of the slide container according to a second embodiment in which two sides of the container are fully open with closing means attached to each of the open sides. The dotted lines delineate the slide receiving means attached to the inside surface of the container.

[0015] **FIG. 4** is a view of the top of the slide container according to a third embodiment in which one or more slits or openings are present.

[0016] **FIG. 5** is a view of the end of the slide container according to a fourth embodiment in which one side is partially open.

#### DETAILED DESCRIPTION OF THE INVENTION

[0017] Referring to **FIG. 1**, a microscope slide container according to the present invention is generally an enclosed container with any suitable shape, *e.g.*, a rectangular container **1** comprising multiple sides, including three sides **2**, a top and bottom side **3**, and a fully open side **12**. The container preferably comprises one or more slide receiving means **16**, wherein each slide receiving means is structured to receive a microscope slide with both sides of the slide exposed to air.

[0018] As illustrated in **FIG. 2**, each receiving means **16** comprises a first holding means **4, 6, 8** and a second holding means **5,7, 9** which together define a compartment in which a microscope slide **S** can be placed. In one embodiment, the distance between the first holding means and the second holding means is equal to the width of a microscope slide. In another embodiment, the distance between the first holding means and the second holding means is equal to the length of a microscope slide. Generally, the first holding means is on a first side of the container and the second holding means is on a second side of the container. Preferably, the first holding means **4, 6, 8** and the second holding means **5,7, 9** are fixed to opposite sides of the container and are in alignment with each other as shown in **FIG. 2**. As can be seen for the first holding means **4, 6, 8** in **FIG. 3** (dotted lines), the first and second holding means may extend longitudinally along the first and second sides of the container, respectively. In some embodiments, the length of the first and second holding means corresponds to the length of a microscope slide. The first and second holding means may be ridges or protuberances that extend from a first and second side of the container into the interior of the container creating a ledge upon which the microscope slide rests. Alternatively, the first and second holding means may be grooves or depressions in a first and second side of the container in which the microscope slide can be secured.

[0019] In one embodiment of the invention, the container **1** comprises a plurality of microscope slides, each of which is positioned in a receiving means **16** of the container. The microscope slides are positioned in the receiving means such that both surfaces of each slide are exposed to air and do not contact adjacent slides or inner surfaces of the container. In some embodiments, the slides may be hematological slides.

[0020] In another embodiment of the invention, the rectangular container **1** comprises a closing means **10** capable of partially closing the open side of the container when it is in a closed position and preventing microscope slides contained inside the container from sliding out of the container (**FIG. 1**). When in the “closed position”, the closing means **10** is positioned to at least partially cover the side of the container that is fully open **12**. The closing means may be perpendicular to the microscope slides placed in the receiving means **16** when it is in the closed position. When the closing means is in the “open position”, as is depicted in **FIG. 1**, one side of the container is fully open and slides can be easily inserted or removed.

[0021] In one embodiment, the closing means is fixed to the open side of the container, *e.g.*, via any suitable attachment to side(s) outlining the open side of the container. The closing means may be fixed to the open side of the container by an adhesive, a rivet, a screw, a snap, or any other suitable attachment means such that the closing means covers partially the open side, *e.g.*, bridges the width of the open side. In another embodiment, the closing means is a piece of material that can be fixed to the open side as well as removable from the open side of the container. The closing means may be any suitable material or shape, *e.g.*, strip of plastic, fabric or any other suitable material, tape, a rubber band, netting, or piece of string, etc.

[0022] In another embodiment of the invention, a fourth side of the rectangular container is partially open. With reference to **FIG. 4**, the top end **3** comprises one or more slits or openings **11** that enhance air flow into the container. The one or more slits or openings may be of any size and shape, such as rectangular, circular, and oblong. Any of the sides, *e.g.*, three sides **2** or top or bottom side **3** may comprise one or more slits or openings. In some embodiments, two or more sides of the container comprise one or more slits or openings.

[0023] Referring to **FIG. 5**, in still another embodiment, a fourth side of the container that is partially open contains a mesh structure **15**, wherein the mesh structure comprises several narrow segments of material attached to the container such that the mesh structure partially covers the open side **14**. The mesh structure is preferably made from a material that is amenable to air passage, such as netting or a woven fabric.

[0024] In some embodiments, the rectangular container may have more than one side fully open. As shown in **FIG. 3**, the rectangular container has a third side that is fully open **12** and a fourth side that is fully open **14**. The two fully open sides are preferably opposite each other. In one embodiment, the rectangular container comprises two closing means capable of preventing microscope slides contained inside the container from sliding out of the container through either of the two fully open sides. A first closing means **10** is fixed at the third side of the container, while the second closing means **13** is fixed at the fourth side of the container.

[0025] The rectangular container may be fabricated from a variety of materials including, but not limited to cardboard, wood, metal, and plastic. In a preferred embodiment, the container is fabricated from a thermoplastic material, such as polystyrene, acrylonitrile butadiene styrene, polyamide, polypropylene, and polyethylene, in an injection molding process.

[0026] The present invention also provides a method of transporting a microscope slide. In one embodiment, the method comprises placing the microscope slide **S** in the receiving means **16** of the rectangular container **1**, and during transportation of the container partially closing the side that is fully open **12** with a closing means **10** to prevent the microscope slide from sliding out of the container. The receiving means holds the microscope slide securely so that there is minimal movement of the microscope slide during transportation. In addition, the receiving means positions the microscope slide such that both surfaces of the slide are exposed to air, which facilitates the complete air-drying of any samples that may be deposited on the microscope slide. Accordingly, microscope slides, especially hematologic slides, can be dried in the container during storage or transport of the container. In another embodiment, the closing means can be removed so that the side of the container is fully open when the container is not in transit.

[0027] The present invention also contemplates a method of drying a microscope slide. In one embodiment, the method comprises placing the microscope slide **S** in the receiving means **16** of the rectangular container **1**. In some embodiments, the microscope slide is a hematologic slide. The microscope slide may be dried during transportation of the container.

[0028] Although specific embodiments of the container and methods of using the container have been described and illustrated, many modifications and substitutions to the structure or methods will be apparent to one of ordinary skill in the art without departing from the spirit or scope of the invention. For example, for use with a rectangular container comprising a fourth side that is partially open, a lid or other type of closure may be used to cover the fully open third side after the slides have been placed into the container. The slide container and methods of use described herein may be used with any type of microscope slide. In particular, the inventive container is useful for the storage and transport of hematological slides.

## Claims:

1. An enclosed rectangular container comprising one or more receiving means,  
wherein each receiving means is structured to receive a microscope slide with both sides of the slide exposed to air, and  
wherein at least one side of the container is fully open.
2. The container of claim 1, wherein each receiving means comprises a first holding means and a second holding means, wherein the first holding means is on a first side of the container and the second holding means is on a second side of the container.
3. The container of claim 2, wherein the first side and the second side are on opposite sides of each other.
4. The container of claim 2, wherein the distance between the first holding means and the second holding means is equal to the width of a microscope slide.
5. The container of claim 2, wherein a third side of the container is fully open and comprises a closing means capable of partially closing the third side of the container when it is in a closed position and preventing microscope slides contained inside the container from sliding out of the container.
6. The container of claim 5, wherein the closing means is removable from the container.
7. The container of claim 5, wherein the closing means is fixed to the third side of the container.
8. The container of claim 5, wherein a fourth side of the container is partially open.
9. The container of claim 1 further comprising a plurality of microscope slides, each of which is positioned in a receiving means of the container.

10. The container of claim 9, wherein the microscope slides are hematologic slides.
11. An enclosed container comprising one or more receiving means, wherein each receiving means is structured to receive a microscope slide with both sides of the slide exposed to air, wherein at least one side of the container is fully open; and wherein said container comprises a closing means capable of partially closing the open side of the container when it is in a closed position and preventing microscope slides contained inside the container from sliding out of the container.
12. The container of claim 11, wherein the closing means is fixed to the container at the open side.
13. A method of transporting a microscope slide comprising placing the microscope slide in the receiving means of the container of claim 1, and during transportation of the container partially closing the side that is fully open with a closing means to prevent the microscope slide from sliding out of the container.
14. The method of claim 13, when the container is not in transit removing the closing means so that the side is fully open.
15. The method of claim 13, wherein the microscope slide is a hematologic slide.
16. A method of drying a microscope slide comprising placing the microscope slide in the receiving means of the container of claim 1.
17. The method of claim 16, wherein the microscope slide is a hematologic slide.
18. The method of claim 16, wherein the microscope slide is dried during transportation of the container.

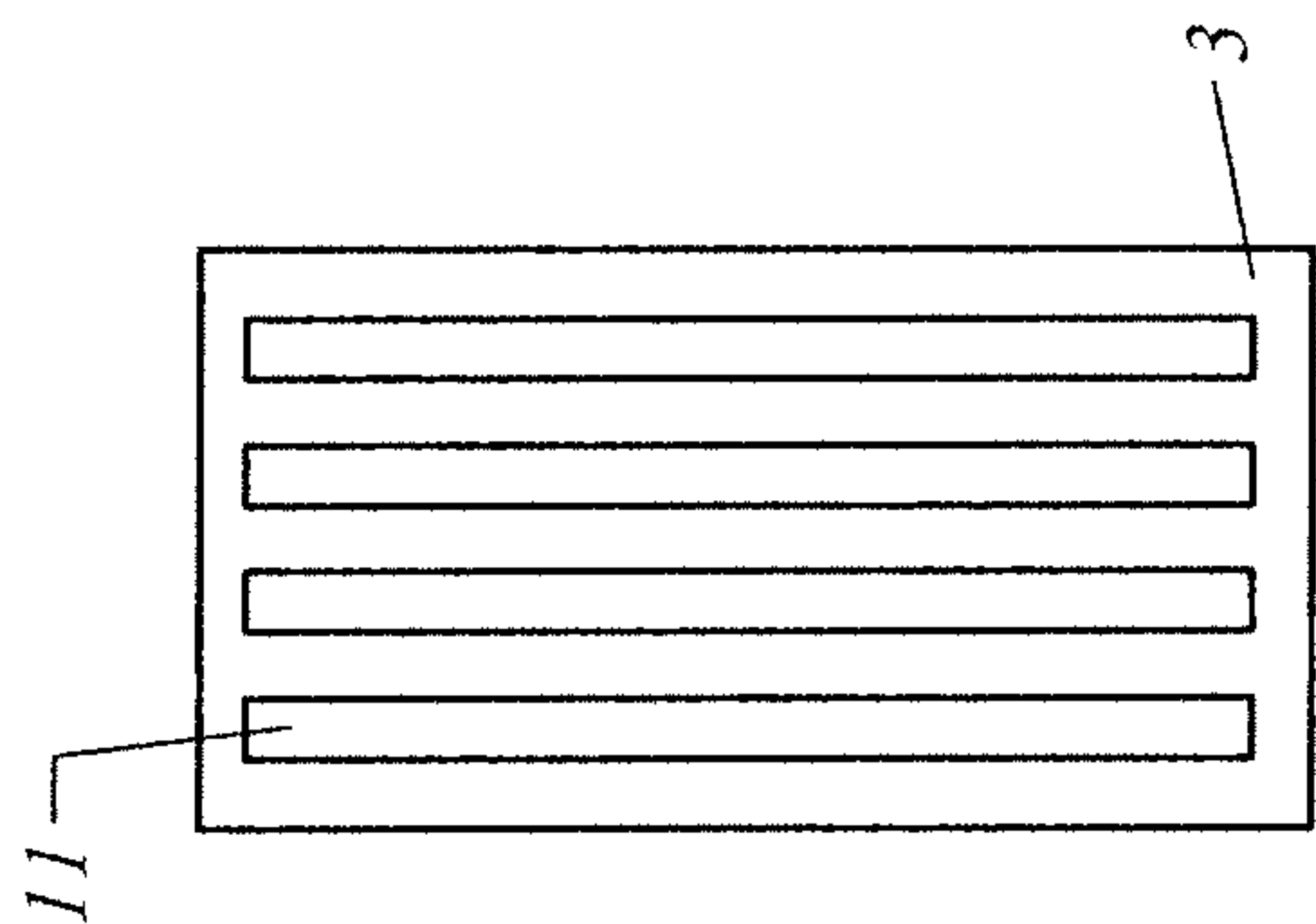

FIG. 4

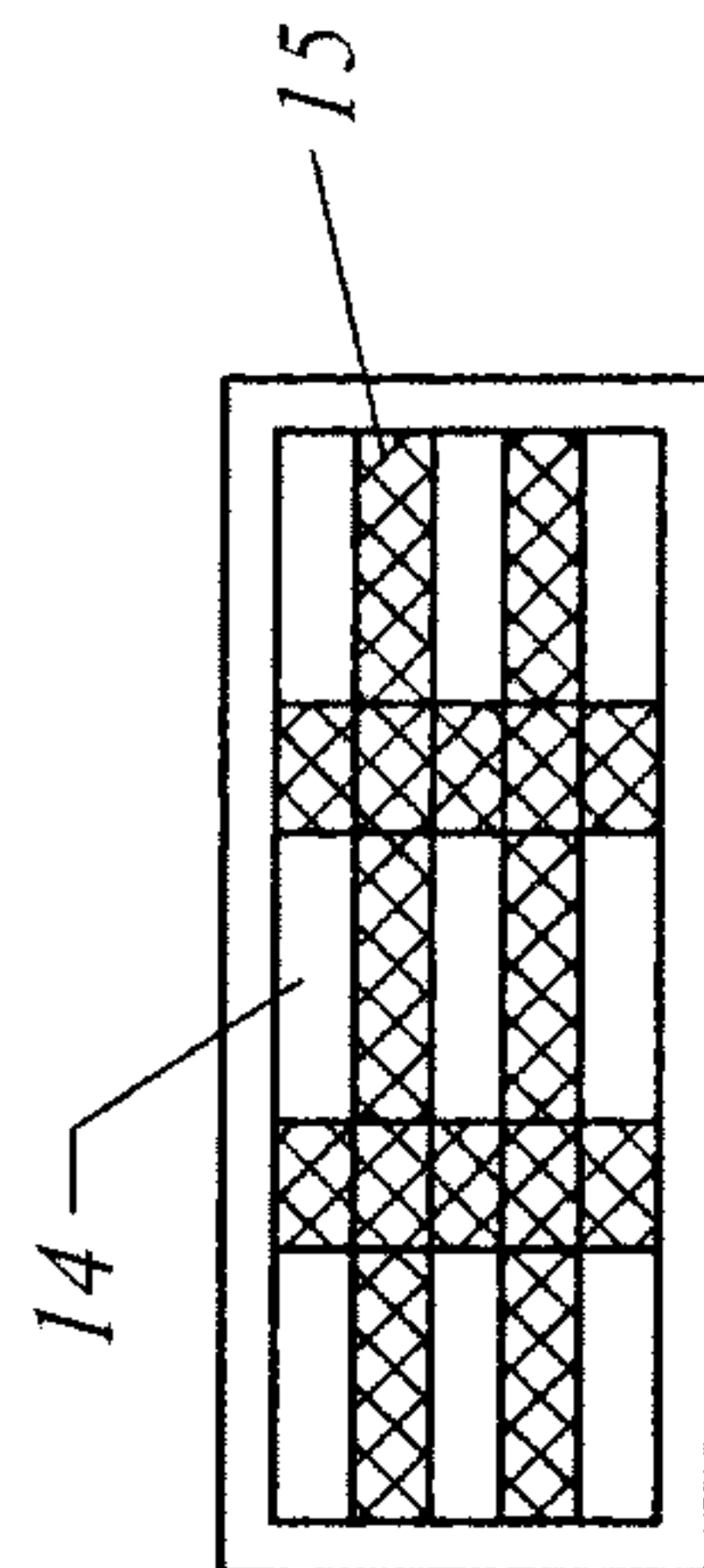

FIG. 5

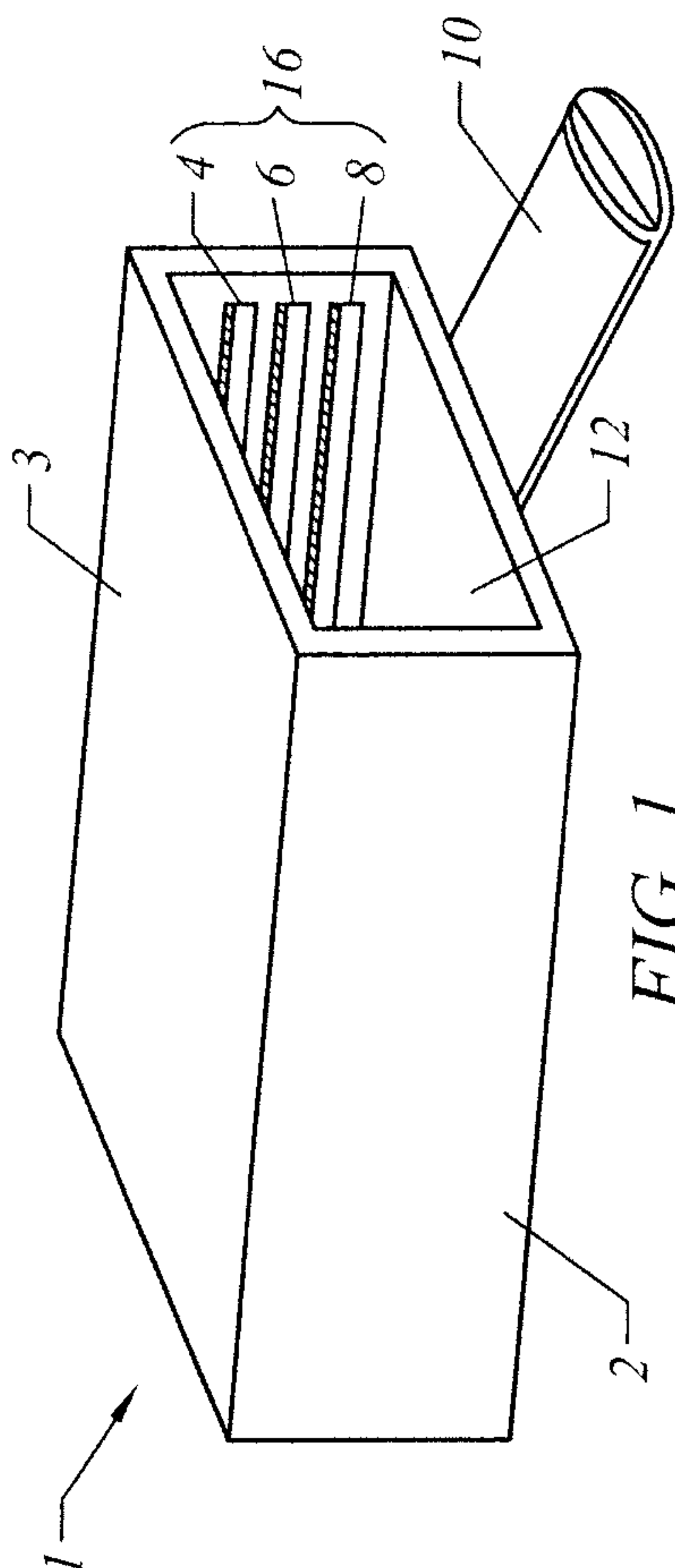

FIG. 1

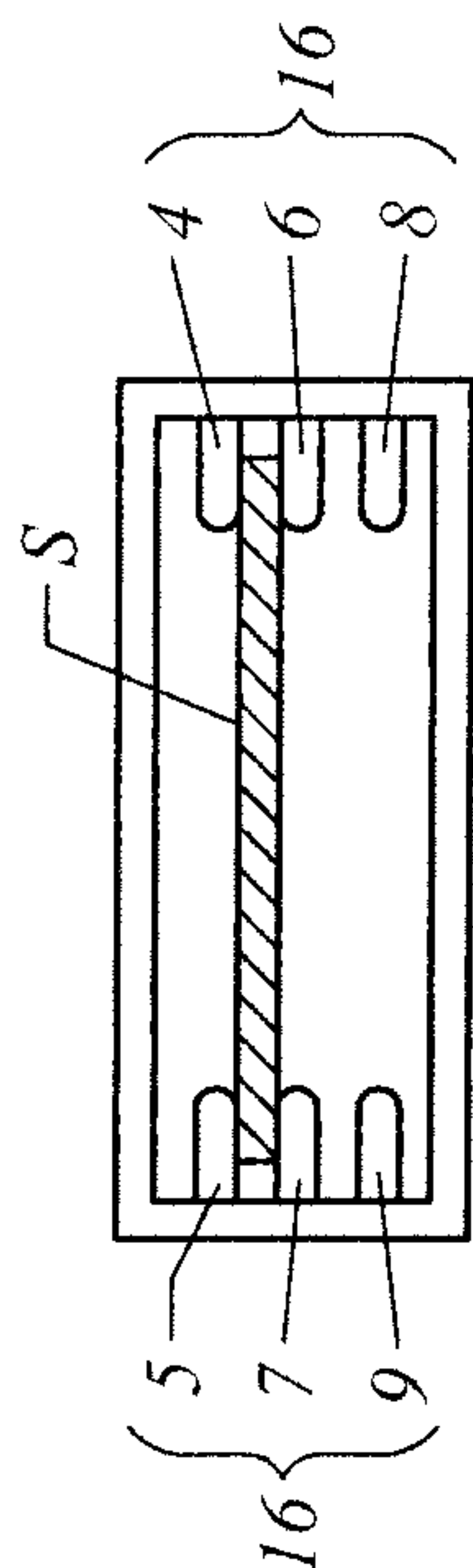

FIG. 2

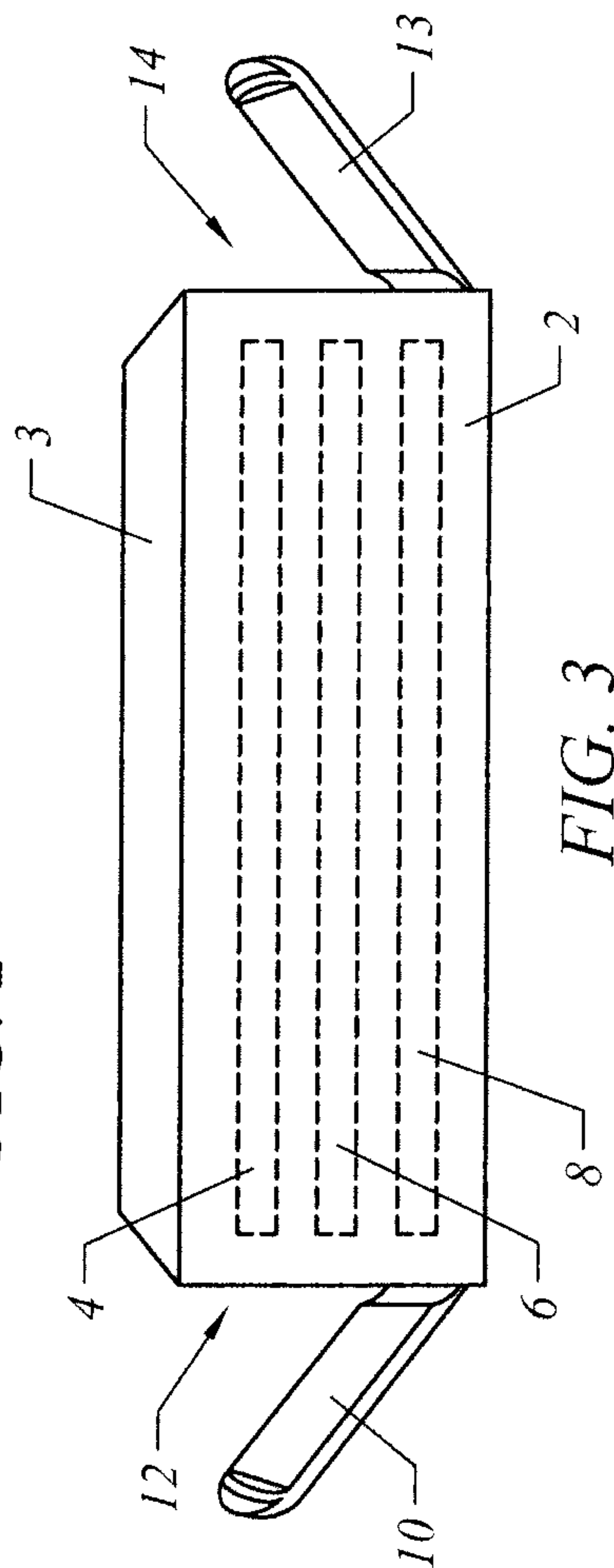
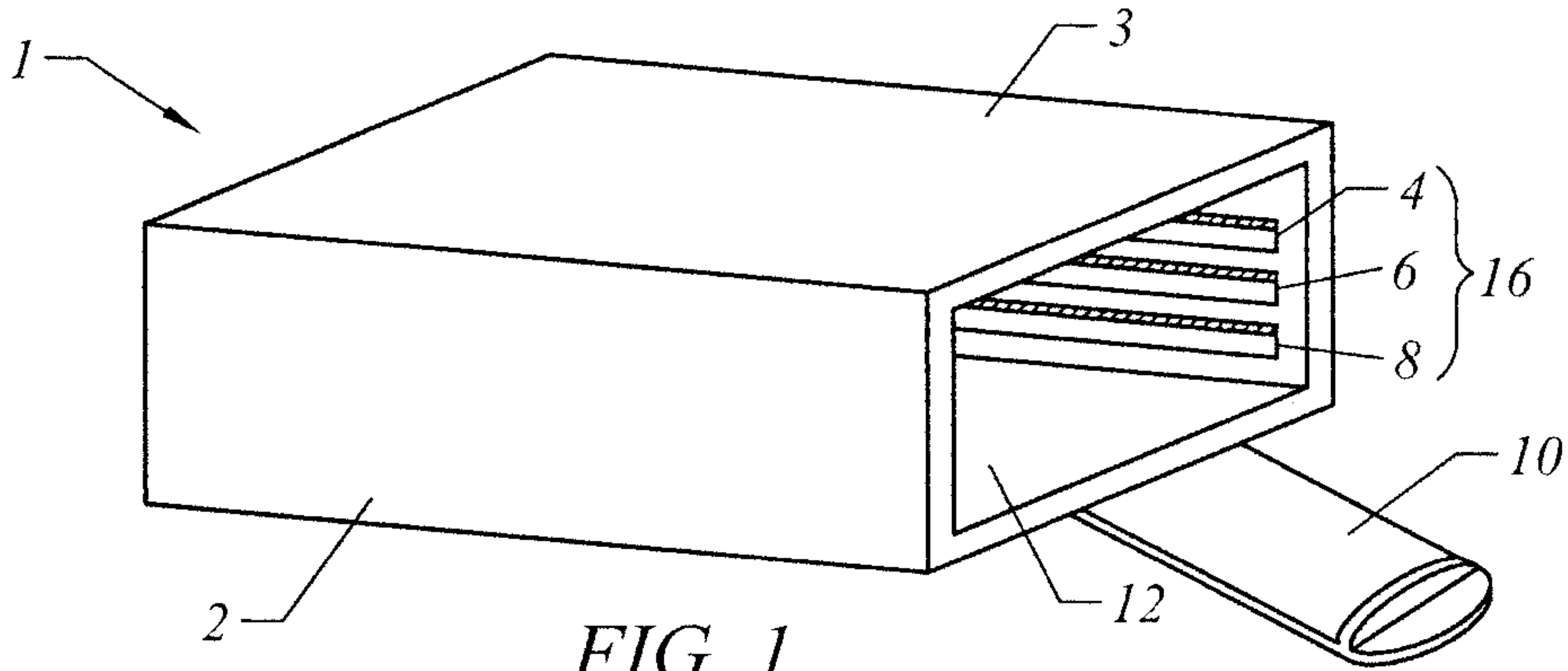

FIG. 3



*FIG. 1*