

(19) World Intellectual Property Organization
International Bureau



(43) International Publication Date
18 February 2010 (18.02.2010)

PCT

(10) International Publication Number
WO 2010/019737 A2

- (51) **International Patent Classification:**
E21B 43/12 (2006.01)
- (21) **International Application Number:**
PCT/US2009/053647
- (22) **International Filing Date:**
13 August 2009 (13.08.2009)
- (25) **Filing Language:** English
- (26) **Publication Language:** English
- (30) **Priority Data:**
12/191,921 14 August 2008 (14.08.2008) US
- (71) **Applicant (for all designated States except US):** **BAKER HUGHES INCORPORATED** [US/US]; P.O. Box 4740, Houston, TX 77210-4740 (US).
- (72) **Inventors; and**
- (75) **Inventors/Applicants (for US only):** **HAMMER, Aaron, C.** [US/US]; 1714 Brun Street, #7, Houston, TX 77019 (US). **HUANG, Tianping, Tim** [US/US]; 19827 Lajuana Lane, Spring, TX 77388 (US). **CREWS, James, B.** [US/US]; 5206 Sunshine Point, Willis, TX 77318 (US). **CORONADO, Martin, P.** [US/US]; 19826 Red Cedar Canyon Lane, Cypress, TX 77429 (US).
- (74) **Agent:** **PORTER, Andre, J.**; Baker Hughes Incorporated, Products & Technology Counsel (baker Oil Tools), P.O. Box 4740, Houston, TX 77210-4740 (US).
- (81) **Designated States (unless otherwise indicated, for every kind of national protection available):** AE, AG, AL, AM, AO, AT, AU, AZ, BA, BB, BG, BH, BR, BW, BY, BZ, CA, CH, CL, CN, CO, CR, CU, CZ, DE, DK, DM, DO, DZ, EC, EE, EG, ES, FI, GB, GD, GE, GH, GM, GT, HN, HR, HU, ID, IL, IN, IS, JP, KE, KG, KM, KN, KP, KR, KZ, LA, LC, LK, LR, LS, LT, LU, LY, MA, MD, ME, MG, MK, MN, MW, MX, MY, MZ, NA, NG, NI, NO, NZ, OM, PE, PG, PH, PL, PT, RO, RS, RU, SC, SD, SE, SG, SK, SL, SM, ST, SV, SY, TJ, TM, TN, TR, TT, TZ, UA, UG, US, UZ, VC, VN, ZA, ZM, ZW.
- (84) **Designated States (unless otherwise indicated, for every kind of regional protection available):** ARIPO (BW, GH, GM, KE, LS, MW, MZ, NA, SD, SL, SZ, TZ, UG, ZM, ZW), Eurasian (AM, AZ, BY, KG, KZ, MD, RU, TJ, TM), European (AT, BE, BG, CH, CY, CZ, DE, DK, EE, ES, FI, FR, GB, GR, HR, HU, IE, IS, IT, LT, LU, LV, MC, MK, MT, NL, NO, PL, PT, RO, SE, SI, SK, SM, TR), OAPI (BF, BJ, CF, CG, CI, CM, GA, GN, GQ, GW, ML, MR, NE, SN, TD, TG).
- Published:**
— without international search report and to be republished upon receipt of that report (Rule 48.2(g))

(54) **Title:** IN-FLOW CONTROL DEVICE UTILIZING A WATER SENSITIVE MEDIA

(57) **Abstract:** An apparatus for controlling fluid flow into a tubular includes an in-flow control device having a plurality of flow paths; and a reactive media disposed in each of the flow paths. The reactive media may change permeability by interacting with a selected fluid such as water. Two or more of the flow paths may be hydraulically parallel. The reactive media may include a Relative Permeability Modifier. An associated method may include conveying the fluid via a plurality of flow paths; and controlling a resistance to flow in plurality of flow paths using a reactive media disposed in each of the flow paths. An associated system may include a wellbore tubular; an in-flow control device; a hydraulic circuit formed in the in-flow control device; and a reactive media disposed in the hydraulic circuit, the reactive media may change permeability by interacting with a selected fluid.



WO 2010/019737 A2

TITLE: IN-FLOW CONTROL DEVICE UTILIZING A WATER SENSITIVE MEDIA

Inventors: Tianping Huang , James Crews, Aaron C. Hammer, Martin Coronado

CROSS-REFERENCE TO RELATED APPLICATIONS

This application is a continuation-in-part from U.S. Patent Application Serial No. 11/871,685 filed October 12, 2007 and also a continuation-in-part of U.S. Patent Application Serial No. 11/875,669 filed October 19, 2007.

BACKGROUND OF THE DISCLOSURE**1. Field of the Disclosure**

[0001] The disclosure relates generally to systems and methods for selective or adaptive control of fluid flow into a production string in a wellbore.

2. Description of the Related Art

[0002] Hydrocarbons such as oil and gas are recovered from a subterranean formation using a wellbore drilled into the formation. Such wells are typically completed by placing a casing along the wellbore length and perforating the casing adjacent each such production zone to extract the formation fluids (such as hydrocarbons) into the wellbore. These production zones are sometimes separated from each other by installing a packer between the production zones. Fluid from each production zone entering the wellbore is drawn into a tubing that runs to the surface. It is desirable to have substantially even drainage along the production zone. Uneven drainage may result in undesirable conditions such as an invasive gas cone or water cone. In the instance of an oil-producing well, for example, a gas cone may cause an in-flow of gas into the wellbore that could significantly reduce oil production. In like fashion, a water cone may cause an in-flow of water into the oil production flow that reduces the amount and quality of the produced oil. Accordingly, it is desired to provide even drainage

across a production zone and / or the ability to selectively close off or reduce in-flow within production zones experiencing an undesirable influx of water and/or gas.

[0003] The present disclosure addresses these and other needs of the prior art.

SUMMARY OF THE DISCLOSURE

[0004] In aspects, the present disclosure provides an apparatus for controlling fluid flow into a bore of a tubular in a wellbore. The apparatus may include an in-flow control device that includes a plurality of flow paths that convey the fluid from the formation into the bore of the wellbore tubular. Two or more of the flow paths may be in hydraulically parallel alignment to allow fluid to flow in a parallel fashion. A reactive media may be disposed in two or more of the flow paths. The reactive media may change permeability by interacting with a selected fluid. In embodiments, the reactive media may interact with water. In some applications, a flow path may be serially aligned with the parallel flow paths. In embodiments, the apparatus may include a flow control element in which hydraulically parallel flow paths are formed. In aspects, the reactive media may include a Relative Permeability Modifier. In embodiments, the reactive media may increase a resistance to flow as water content increases in the fluid from the formation and decrease a resistance to flow as water content decreases in the fluid from the formation. The reactive media may be formulated to change a parameter related to the flow path. Exemplary parameters include, but are not limited to permeability, tortuosity, turbulence, viscosity, and cross-sectional flow area.

[0005] In aspects, the present disclosure provides a method for controlling a flow of a fluid into a tubular in a wellbore. The method may include conveying the fluid via a plurality of flow paths from the formation into the wellbore tubular; and controlling a resistance to flow in a plurality of flow paths using a reactive media disposed in two or more of the flow paths. Two or more of the flow paths may be in hydraulically parallel alignment. In aspects, the method may also include reconfiguring the reactive media *in situ*.

[0006] In aspects, the present disclosure further provides a system for controlling a flow of a fluid from a subsurface formation. The system may include a wellbore tubular having a bore configured to convey the fluid from the subsurface formation to the surface; an in-flow control device positioned in the wellbore; a hydraulic circuit formed in the in-flow control device that conveys the fluid from the formation into the bore of the wellbore tubular; and a reactive media disposed in the hydraulic circuit that changes permeability by interacting with a selected fluid. The hydraulic circuit may include two or more hydraulically parallel flow paths. In aspects, the system may include a configuration tool that configures the reactive media *in situ*. The hydraulic circuit may include a first set of parallel flow paths in serial alignment with a second set of parallel flow paths.

[0007] It should be understood that examples of the more important features of the disclosure have been summarized rather broadly in order that detailed description thereof that follows may be better understood, and in order that the contributions to the art may be appreciated. There are, of course, additional features of the disclosure that will be described hereinafter and which will form the subject of the claims appended hereto.

BRIEF DESCRIPTION OF THE DRAWINGS

[0008] The advantages and further aspects of the disclosure will be readily appreciated by those of ordinary skill in the art as the same becomes better understood by reference to the following detailed description when considered in conjunction with the accompanying drawings in which like reference characters designate like or similar elements throughout the several figures of the drawing and wherein:

FIG. 1 is a schematic elevation view of an exemplary multi-zonal wellbore and production assembly that incorporates an in-flow control system in accordance with one embodiment of the present disclosure;

FIG. 2 is a schematic elevation view of an exemplary open hole production assembly that incorporates an in-flow control system in accordance with one embodiment of the present disclosure;

FIG. 3 is a schematic cross-sectional view of an exemplary production control device made in accordance with one embodiment of the present disclosure;

FIG. 4 schematically illustrates an exemplary in-flow control device made in accordance with one embodiment of the present disclosure;

FIGS. 5 and 6 illustrate exemplary responses for in-flow control devices made in accordance with the present disclosure;

FIG. 7 schematically illustrates an exemplary arrangement for flow control elements utilized in an in-flow control device made in accordance with the present disclosure; and

FIG. 8 schematically illustrates a subsurface production device utilizing in-flow control devices made in accordance with the present disclosure and an illustrative configuration device for configuring such in-flow control devices.

DETAILED DESCRIPTION OF THE PREFERRED EMBODIMENTS

[0009] The present disclosure relates to devices and methods for controlling fluid production at a hydrocarbon producing well. The present disclosure is susceptible to embodiments of different forms. There are shown in the drawings, and herein will be described in detail, specific embodiments of the present disclosure with the understanding that the present disclosure is to be considered an exemplification of the principles of the disclosure, and is not intended to limit the disclosure to that illustrated and described herein.

[0010] In embodiments, the flow of formation fluids into the wellbore tubular of an oil well may be controlled, at least in part, by using an in-flow control device that contains a media that may interact with one or more specified fluids produced from an underground formation. The interaction may be calibrated or engineered such that a flow parameter (e.g., flow rate) of the in-flowing formation fluid varies according to a predetermined relationship to a selected fluid parameter (e.g., water content, fluid velocity, gas content, etc.). The media may include a material that interacts chemically, ionically, and/or mechanically with a component of the in-flowing formation fluids in a prescribed manner. This interaction may vary a resistance to flow across the in-flow control device such that a desired value or values for a selected flow parameter such as flow rate is established for in-flow control device. While the teachings of the present disclosure may be applied to a variety of subsurface applications, for simplicity, illustrative embodiments of such in-flow control devices will be described in the context of hydrocarbon production wells.

[0011] Referring initially to FIG. 1, there is shown an exemplary wellbore 10 that has been drilled through the earth 12 and into a pair of formations 14, 16 from which it is desired to produce hydrocarbons. The wellbore 10 is cased by metal casing and cement, as is known in the art, and a number of perforations 18 penetrate and extend into the formations 14, 16 so that production fluids may flow from the formations 14, 16 into the wellbore 10. The wellbore 10 has a deviated, or substantially horizontal leg 19. The wellbore 10 has a late-stage production assembly, generally indicated at 20, disposed therein by a tubing string 22 that extends downwardly from a wellhead 24 at

the surface 26 of the wellbore 10. The production assembly 20 defines an internal axial flowbore 28 along its length. An annulus 30 is defined between the production assembly 20 and the wellbore casing. The production assembly 20 has a deviated, generally horizontal portion 32 that extends along the deviated leg 19 of the wellbore 10. Production nipples 34 are positioned at selected points along the production assembly 20. Optionally, each production device 34 is isolated within the wellbore 10 by a pair of packer devices 36. Although only two production devices 34 are shown in FIG. 1, there may, in fact, be a large number of such production devices arranged in serial fashion along the horizontal portion 32.

[0012] Each production device 34 features a production control device 38 that is used to govern one or more aspects of a flow of one or more fluids into the production assembly 20. As used herein, the term "fluid" or "fluids" includes liquids, gases, hydrocarbons, multi-phase fluids, mixtures of two or more fluids, water, brine, engineered fluids such as drilling mud, fluids injected from the surface such as water, and naturally occurring fluids such as oil and gas. Additionally, references to water should be construed to also include water-based fluids; e.g., brine or salt water. In accordance with embodiments of the present disclosure, the production control device 38 may have a number of alternative constructions that ensure selective operation and controlled fluid flow therethrough.

[0013] FIG. 2 illustrates an exemplary open hole wellbore arrangement 11 wherein the production devices of the present disclosure may be used. Construction and operation of the open hole wellbore 11 is similar in most respects to the wellbore 10 described previously. However, the wellbore arrangement 11 has an uncased and no cementing borehole that is directly open to the formations 14, 16. Production fluids, therefore, flow directly from the formations 14, 16, and into the annulus 30 that is defined between the production assembly 21 and the wall of the wellbore 11. There are no perforations, and open hole packers 36 may be used to isolate the production control devices 38. The nature of the production control device is such that the fluid flow is directed from the formation 16 directly to the nearest production device 34, hence resulting in a balanced

flow. In some instances, packers may be omitted from the open hole completion.

[0014] Referring now to **FIG. 3**, there is shown one embodiment of a production control device **100** for controlling the flow of fluids from a reservoir into a flow bore **102** of a tubular **104** along a production string (e.g., tubing string **22** of **FIG. 1**). An opening **122** allows fluids to flow between the production control device **100** and the flow bore **102**. This flow control can be a function of one or more characteristics or parameters of the formation fluid, including water content, pressure, fluid velocity, gas content, etc. Furthermore, the control devices **100** can be distributed along a section of a production well to provide fluid control at multiple locations. This can be advantageous, for example, to equalize production flow of oil in situations wherein a greater flow rate is expected at a "heel" of a horizontal well than at the "toe" of the horizontal well. By appropriately configuring the production control devices **100**, such as by pressure equalization or by restricting in-flow of gas or water, a well owner can increase the likelihood that an oil bearing reservoir will drain efficiently. Exemplary production control devices are discussed herein below.

[0015] The production control device **100** may include one or more of the following components: a particulate control device **110** for reducing the amount and size of particulates entrained in the fluids, a flow management device **120** that controls one or more drainage parameters, and / or an in-flow control device **130** that controls flow based on the composition of the in-flowing fluid. The particulate control device **110** can include known devices such as sand screens and associated gravel packs. The in-flow control device **120** includes a plurality of flow paths between a formation and a wellbore tubular that may be configured to control one or more flow characteristics such as flow rates, pressure, etc. For example, the flow management device **120** may utilize a helical flow path to reduce a flow rate of the in-flowing fluid. While the in-flow control device **130** is shown downstream of the particulate control device **110** in **FIG. 3**, it should be understood that the in-flow control device **130** may be positioned anywhere along a flow path between the formation and the flow bore **102**. For instance, the in-flow control device **130** may be integrated into the particulate control device **110**. Furthermore, the in-flow control device may be a "stand-alone" device that may be

utilized without a particulate control device **110** or flow management device **120**. Illustrative embodiments are described below.

[0016] Turning to **FIG. 4**, there is shown an exemplary embodiment of an in-flow control device **130**. In one embodiment, the in-flow control device **130** may be configured to provide dynamic control over one or more flow parameters associated with the in-flowing fluid. By dynamic, it is meant that the in-flow control device **130** may impose a predetermined flow regime that is a function of one or more variable downhole conditions such as the amount of water in an in-flowing fluid. Exemplary flow regimes or functional responses utilized by the in-flow control device **130** are discussed below.

[0017] Referring now to **Fig. 5**, there are shown illustrative flow regimes that may be utilized by the in-flow control device **130**. As shown in **Fig. 5**, a flow rate may be controlled in response to the amount of water, or water content, in a fluid flowing through the in-flow control device **130**. In **Fig. 5**, the x-axis corresponds to a percentage of water in the in-flowing fluid, or "water cut," and the y-axis corresponds to a percentage of a maximum flow rate through the in-flow control device **130**. The in-flow control device may be configured have a variety of different predetermined responses to water content and changes in water content in the in-flowing fluid. These responses may, in embodiments, be characterized by mathematical relationships. Additionally, the in-flow control devices **130** may control flow rates as water content both increases and decreases. That is, the flow rate control may be bi-directional / reversible and dynamic / adaptive. By dynamic / adaptive, it is meant that the in-flow control device **130** is responsive to changes in the downhole environment. Additionally, the bi-directional or reversible aspect of the in-flow control device **130** may be maintained by configuring the in-flow control device **130** to always allow a minimal amount of flow even at very high water cuts.

[0018] In a first example, the behavior of the in-flow device **130** may be characterized by line **140** wherein flow rates are held substantially constant when the in-flow is mostly water or mostly oil but varied in the intermediate region where the oil-water ratio is more balanced. The line **140** may have a first segment represented between point **142** and

point **144** wherein a generally static or fixed maximum flow rate, e.g., one-hundred percent, is provided for water cut that ranges from about zero percent to perhaps fifty percent. From point **144** to point **146**, flow rate varies inversely and in a linear fashion with the increase in water cut. Point **146** may roughly represent a flow rate of ten percent at a water ratio of eighty-five percent. Thereafter, the increase in water cut beyond eight-five percent does not change the flow rate. That is, the flow rate may remain at ten percent for water cut beyond eighty-five percent. The in-flow control device **130** may be configured to control flow rates in both directions along line **140**.

[0019] In a second example, the behavior of the in-flow device **130** may be characterized by line **148** wherein the flow rate is varied inversely with water cut as long as the water cut remains below a threshold value. Above the threshold value, the flow rate is held substantially constant. The line **148** may have a first segment represented between point **142** and point **150**. Point **142** may represent a maximum flow rate at zero percent water cut and point **150** may represent ten percent flow rate at fifty percent water cut. The line between **142** and point **150** may be approximated by a mathematical relationship wherein flow rate varies inversely and non-linearly with the increase in water cut. Thereafter, the increase in water cut beyond fifty percent does not change the flow rate. That is, the flow rate may remain at ten percent for water cut beyond fifty percent.

[0020] In a third example, the behavior of the in-flow device **130** may be characterized by line **152** wherein flow rate versus water cut is governed by a relatively complex relationship for a portion of the water cut range. The line **152** may include multiple segments **154**, **156**, **158** between points **142** and **150**. Each segment **154**, **156**, **158** may reflect different relationships for flow rate versus water cut. The first segment **154** may utilize a steep negative slope and be linear. The second segment **156** may be a plateau-type of region wherein flow rate does not vary with changes in water cut. The third segment **158** may be a relatively non-linear region wherein the flow rate varies inversely with water cut, but not according to a smooth curve. Thereafter, the increase in water cut beyond fifty percent does not change the flow rate. That is, the flow rate may remain at ten percent for water cut beyond fifty percent.

[0021] Referring now to **Fig. 6**, there are shown other illustrative flow regimes that may be utilized by the in-flow control device **130**. In **Fig. 6**, the x-axis corresponds to a percentage of water in the in-flowing fluid, or "water cut," and the y-axis corresponds to a percentage of a maximum flow rate through the in-flow control device **130**. The in-flow control device **130** may be configured have a relatively complex response to changes in water cut. Further, the flow rate for a given water cut may be a function of a water cut previously encountered by the in-flow control device **130**. That is, while the in-flow control device **130** may be bi-directional or reversible, a first flow rate-to-water cut relationship may govern flow rates as water cut increases and a second flow rate-to-water cut relationship may govern flow rates as water cut decreases.

[0022] For example, a line **160** illustrating an asymmetric response to water cut variations may be defined by points **162**, **164**, **166**, **168** and **170**. At point **162**, a maximum flow rate is provided for zero water cut. As water cut increases, the flow rate is reduced in a relatively linear manner up to point **164**, which may represent a ten percent flow rate at sixty percent water cut. From point **164** to point **166**, which may be ninety percent water cut or higher, the flow rate remains relatively unchanged at ten percent. As water cut decreases from some point between **164** and point **166**, the in-flow control device **130** exhibits a different flow rate to water cut ratio relationship. For instance, as water cut decreases from point **166**, the flow rate may remain unchanged until point **168**. That is, the flow rate response may not follow a path along the line between point **164** and **162**. Point **168** may represent a ten percent flow rate at fifty percent water cut. As water cut drops below fifty percent, the flow rate increases according to the line between point **168** and point **170**. It should be noted that as water cut reverts to zero, the flow rate may be lower than the maximum flow rate at point **162**. Thus, while the response line **160** reflects a reversible or bi-directional behavior of the in-flow control device **130**, the flow rate variation associated with increasing water cut may not correspond or match the flow rate variation associated with decreasing water cut. This asymmetric behavior may be predetermined by formulating the reactive material to vary response as a function of the direction of change in water cut. In other instances, the asymmetric behavior may be due to limitations in a material's ability to fully revert to a prior shape, state, or condition. In still other instances, a time lag may

occur between a time that a water cut dissipates in the in-flowing fluid and the time the water interacting with the reactive material is scoured or adequately removed from the reactive material to allow the material to return to a prior state.

[0023] Another response wherein the flow rate is dependent upon the direction of change in water cut is shown by line **172**. Line **172** may be defined by points **162**, **174**, **176** and **170**. At point **162**, a maximum flow rate is provided for zero water cut. As water cut increases, the flow rate is reduced in a relatively linear manner up to point **174**, which may represent a ten percent flow rate at forty percent water cut. From point **174** to point **176**, the flow rate remains relatively unchanged at ten percent as water cut decreases. As water cut decreases from point **176**, the flow rate increases according to the line or curve between point **176** and point **170**. It should be noted that as water cut reverts to zero, the flow rate may be lower than the maximum flow rate at point **162**. Thus, as before, while the response line **172** reflects a reversible or bi-directional behavior of the in-flow control device **130**, the flow rate variation associated with increasing water cut may not correspond or match the flow rate variation associated with decreasing water cut.

[0024] Referring now to **Fig. 4**, in embodiments, the in-flow control device **130** may include one or more flow control elements **132a,b,c** that cooperate to establish a particular flow regime or control a particular flow parameter for the in-flowing fluid. While three flow control elements are shown, it should be understood that any number may be used. Because the flow control elements **132a,b,c** may be generally similar in nature, for convenience, reference is made only to the flow control element **132a**. The flow control element **132a**, which may be formed as a disk or ring, may include a circumferential array of one or more flow paths **134**. The flow paths **134** provide a conduit that allows fluid to traverse or cross the body of the flow control element **132a**. It should be appreciated that flow paths **134** provide hydraulically parallel flow across the flow control element **132a**. Hydraulically parallel, in one aspect, refers to two or more conduits that each independently provide a fluid path to a common point or a fluid path between two common points. In another aspect, hydraulically parallel flow paths include flow paths that share two common points (e.g., an upstream point and a

downstream point). By share, it is meant fluid communication or a hydraulic connection with that common point.

[0025] Thus, generally speaking, the flow paths **134** provide fluid flow across each of their associated flow control elements **132a,b,c**. Of course, if only a single flow path **134** is present, then the flow is better characterized as a serial flow across the flow control element **132a,b,c**.

[0026] In embodiments, each flow path **134** may be partially or completely packed or filled with a reactive permeable media **136** that controls a resistance to fluid flow in a predetermined manner. Suitable elements for containing the reactive media **136** in the flow channels include, but are not limited to, screens, sintered bead packs, fiber mesh etc. The permeable media **136** may be engineered or calibrated to interact with one or more selected fluids in the in-flowing fluid to vary or control a resistance to flow across the flow path in which the reactive media **136** resides. By calibrate or calibrated, it is meant that one or more characteristics relating to the capacity of the media **136** to interact with water or another fluid component is intentionally tuned or adjusted to occur in a predetermined manner or in response to a predetermined condition or set of conditions. In one aspect, the resistance is controlled by varying the permeability across the flow path **134**.

[0027] Referring now to **Fig. 7**, the flow path of the in-flowing fluid across the in-flow control device **130** is schematically illustrated as a hydraulic circuit. As shown, the flow control elements **132a,b,c** are arranged in a serial fashion whereas the flow paths **134a1-an, b1-bn, c1-cn** within each flow control element **132a,b,c** are hydraulically parallel. In this regard, the flow paths may be considered branches making up the hydraulic circuit. For example, flow control element **132a** includes a plurality of flow paths **134a1-an**, each of which may be structurally parallel. That is, each flow path **134a** provides a hydraulically independent conduit across the flow control element **132a**. Each of the flow control elements **132a,b,c** may be separated by an annular flow space **138**. In an exemplary flow mode, fluid flows in a parallel fashion from a common point via at least two branches / flow paths **134** across the first flow control element **132a**. The flow paths **134** in the first flow control element **132a** may each present the

same or different resistance to flow for that fluid and that resistance may vary depending on fluid composition, e.g., water cut. The fluid then exits at a common point and commingles in the annular space **138** separating the first flow control element **132a** and the second flow control element **132b**. The fluid flows in a parallel fashion across the second flow control element **132a** and commingles in the annular space **138** separating the second flow control element **132b** and the third flow control element **132c**. The flow paths **134** in the second flow control element **132b** may also each present the same or different resistance to flow for that fluid. A similar flow pattern occurs through the remaining flow control elements. It should be understood that each flow control element **132a,b,c** as well as each annular space **138** may be individually configured to induce a change in a flow parameter or impose a particular flow parameter (e.g., pressure or flow rate). In one aspect, the hydraulic circuit may include sets of branches that are serially aligned. One or more of the set of branches may have two or more branches that are hydraulically parallel. Thus, the use of a combination of serial and parallel flow paths as well as the annular spaces extends the range and sophistication of the response of the in-flow control device **130** to changes in water cut in the in-flowing fluid.

[0028] For example, in embodiments, the reactive permeable media **136** in at least two of the flow paths **134a1-an** may be formulated to react differently when exposed to a same water cut. For example, for a 15% water cut, the media in half of the flow paths **134a1-an** may have a first relatively low resistance to flow (e.g., relatively high permeability) whereas the media in the other half of the flow paths **134a1-an** may have a high resistance to flow (e.g., a relatively low permeability). In another example, the media in each of the flow paths **134a1-an** may have a distinct and different response to particular water cut. Thus, for instance, the permeable media **136** in flow path **134a1** may exhibit a substantial decrease in permeability when exposed a 15% water cut and the media **136** in flow path **134an** may exhibit a substantial decrease in permeability only when exposed to a 50% water cut. The media **136** in the intermediate flow paths, media **136a2-a(n-1)**, may each exhibit a graduated or proportionate decrease in permeability for water cut values between 15% and 50%. That is, the media in one these intermediate flow paths may exhibit an incrementally different reaction to a water

cut than the media in an adjacent flow path. The flow paths in the flow elements **132b,c** may be configured in the same manner or a different manner.

[0029] In a manner somewhat analogous to an electrical circuit, therefore, the permeability / resistance in each of the flow paths of the in-flow control device **130** as well as their relative structure (*e.g.*, parallel and/or serial branches) may be selected to enable the in-flow control device **130** to exhibit a desired response to an applied input. Additionally, the permeability / resistance may be relative to water cut and, therefore, variable. Thus, it should be appreciated that numerous variations or permutations are available and may be utilized to achieve a predetermined flow regime or characteristic for the in-flow control device **130**.

[0030] In embodiments, the reactive permeable media **136** may include a water sensitive media. One non-limiting example of a water sensitive media is a Relative Permeability Modifier (RPM). Materials that may function as a RPM are described in U.S. Patent Nos. 6,474,413, 7,084,094, 7,159,656, and 7,395,858, which are hereby incorporated by reference for all purposes. The Relative Permeability Modifier may be a hydrophilic polymer. This polymer may be used alone or in conjunction with a substrate. In one application, the polymer may be bonded to individual particles of a substrate. Example substrate materials include sand, gravel, metal balls, ceramic particles, and inorganic particles, or any other material that is stable in a down-hole environment. The substrate may also be another polymer. To obtain a desired permeability or reactivity for a given input such as in-flowing fluid having a particular water cut, the properties of the water sensitive material may be varied by changing the polymer (type, composition, combinations, etc), the substrate (type, size, shape, combinations, etc) or the composition of the two (amount of polymer, method of bonding, configurations, etc). In one non-limiting example, when water flows in, around or through RPM modified permeable media, the hydrophilic polymers coated on the particles expand to reduce the available cross-sectional flow area for the fluid flow channel, which increases resistance to fluid flow. When oil and/or gas flow through this permeable media, the hydrophilic polymers shrink to open the flow channel for oil and/or gas flow. Additionally, a polymer may be infused through a permeable material such as a sintered metal bead pack, ceramic material, permeable natural formations,

etc. In such a case, the polymer could be infused through a substrate. Additionally, a permeable foam of the polymer may be constructed from the reactive media.

[0031] In embodiments, the media may be particulated, such as a packed body of ion exchange resin beads. The beads may be formed as balls having little or no permeability. When exposed to water, the ion exchange resin may increase in size by absorbing the water. Because the beads are relatively impermeable, the cross-sectional flow area is reduced by the swelling of the ion exchange resin. Thus, flow across a flow channel may be reduced or stopped. In embodiments, the material in the flow path may be configured to operate according to HPLC (high performance liquid chromatography). The material may include one or more chemicals that may separate the constituent components of a flowing fluid (e.g., oil and water) based on factors such as dipole-dipole interactions, ionic interactions or molecule sizes. For example, as is known, an oil molecule is size-wise larger than a water molecule. Thus, the material may be configured to be penetrable by water but relatively impenetrable by oil. Such a material then would retain water. In another example, ion-exchange chromatography techniques may be used to configure the material to separate the fluid based on the charge properties of the molecules. The attraction or repulsion of the molecules by the material may be used to selectively control the flow of the components (e.g., oil or water) in a fluid.

[0032] In embodiments, the reactive media **136** may be selected or formulated to react or interact with materials other than water. For example, the reactive media **136** may react with hydrocarbons, chemical compounds, bacteria, particulates, gases, liquids, solids, additives, chemical solutions, mixtures, etc. For instance, the reactive media may be selected to increase rather than decrease permeability when exposed to hydrocarbons, which may increase a flow rate as oil content increases.

[0033] Each flow path in the in-flow control device may be specifically configured to exhibit a desired response (e.g., resistance, permeability, impedance, etc.) to fluid composition (e.g., water cut) by appropriately varying or selecting each of the above-described aspects of the media. The response of the water sensitive media may be a gradual change or a step change at a specified water cut threshold. Above the

threshold the resistance may greatly increase as in a step wise fashion. As will be appreciated, any of the flow rate versus water cut relationships shown in **Figs. 5 and 6**, as well as other desired relationships, may be obtained by appropriate selection of the material for the reactive media **136** and arrangement of the reactive media **136** along the in-flow control device **130**.

[0034] It should be appreciated that the use of a water sensitive material within a tool deployed into a wellbore permits the water sensitive material to be calibrated, formulated and/or manufactured with a degree of precision that may not possible if the water sensitive material was injected directly into a formation. That is, the ability of applying one or more water sensitive materials to one or more permeable media substrates within one or more flow paths of a tool under controlled environmental conditions at a manufacturing facility can be done with a higher degree of precision and specifications as compared to when the water sensitive materials are pumped from the surface down casing or tubing into a subterranean formation and applied to the reservoir during downhole conditions that may not be stable or easily controlled. Additionally, because the water sensitive material-based in-flow control device is configured prior to deployment of the wellbore, the operating characteristics or behavior of such an in-flow control device may be "tuned to" or matched to an actual or predicted formation condition and/or fluid composition from a particular formation. Furthermore, in embodiments, the in-flow control device may be re-configured or adjusted *in situ*.

[0035] Referring now to **Fig. 8**, there is shown a production well **200** having production control devices **202, 204, 206** that control in-flow of formation fluids from reservoirs **208, 210, 212**, respectively. While the production control devices **202, 204, 206** are shown relatively close to one another, it should be understood that these devices may be separated by hundreds of feet or more. The production control devices **202, 204, 206** may each include water sensitive material to control one or more flow parameters of in-flowing fluid as described above. Advantageously, embodiments of the present disclosure provide the flexibility to configure, re-configure, replenish, dewater or otherwise adjust one or more characteristics of the production control

devices **202**, **204**, **206**. Moreover, each of the production control devices **202**, **204**, **206** may be independently adjusted *in situ*.

[0036] Furthermore, referring to **Fig. 8**, the production control devices **202**, **204**, **206** that control in-flow of formation fluids may each include a hydrophobic material on the permeable media substrate to control one or more flow parameters of in-flowing fluid as described above. For example, use of hydrophobic material coated permeable media substrate in one or more flow paths can be of utility for optimizing a tool's sensitivity to select water/oil ratios, such as at higher water/oil ratios. Another non-limiting example may be for wells having higher flow rates with select water/oil ratios. Still another non-limiting example can be for select flow path and permeable media substrate sizing configurations.

[0037] In one embodiment, a configuration tool **220** may be conveyed via a conveyance device **222** into the well **200**. Seals **224** associated with the configuration tool **220** may be activated to isolate the configuration tool **220** and the production control device **204** from production control devices **202** and **206**. This isolation ensures that fluids or other materials supplied by the configuration tool **220** may be transmitted to affect only the production control device **204**. Thereafter, the conveyance device **222** may be operated to configure the production control device **204**. For example, the configuration tool **220** may inject an additive, a slurry, an acid or other material that reacts with the WSM in the production control device **204** in a prescribed manner. The fluid may be pumped from the surface via the conveyance device **220**, which may be coiled tubing or drill string. The fluid may also be injected using a bailer configured to receive a pressurized fluid from a pump (not shown). Referring now to **Figs. 3** and **8**, the fluid supplied by the conveyance device **220** may flow from the flow bore **102** into the production control device **204** /**100** via the openings **122**. Other modes for configuring or reconfiguring the production control device **204** may include applying energy (e.g., thermal, chemical, acoustical, etc.) using the configuration device **220** and mechanically scouring or cleaning the production control device **204** using a fluid, *i.e.*, a mechanical as opposed to chemical interaction.

[0038] In illustrative operating modes, the configuration tool **220** may inject a fluid that dewateres the water sensitive material in the production control device **204** to thereby reestablish in-flow across the production control device **204**. In another application, the configuration tool **220** may inject a material that or decreases the reactivity of the water sensitive material. For instance, the injected material may transform a water sensitive material that has a 50% water cut threshold to a water sensitive material that has a 30% or 80% water cut threshold. Also, the injected material may replace a first water sensitive material with a second different water sensitive material. Further, in one scenario, analysis of formation fluids from the reservoir **210** may be utilized to configure the production control device **204** at the surface. Thereafter, the production control device **204** may be conveyed into and installed in the well **200** adjacent to the reservoir **210**. Some time thereafter, an analysis of the fluid from reservoir **201** may indicate that a change in one or more characteristics of the production control device **204** may yield a more desirable in-flow rate, which may be higher or lower. Thus, the configuration device **220** may be conveyed into the well **200** and operated to make the desired changes to the production control device **204**. In another scenario, the production control device **204** may utilize a water sensitive material that degrades in effectively after some time period. The configuration device **220** may be deployed periodically into the well **220** to refurbish the production control device **204**.

[0039] It should be understood that **FIGS. 1** and **2** are intended to be merely illustrative of the production systems in which the teachings of the present disclosure may be applied. For example, in certain production systems, the wellbores **10**, **11** may utilize only a casing or liner to convey production fluids to the surface. The teachings of the present disclosure may be applied to control flow through these and other wellbore tubulars.

[0040] Thus, what has been described includes, in part, an apparatus for controlling a flow of a fluid between a bore of a tubular in a wellbore. The apparatus may include an in-flow control device that includes a plurality of flow paths, two or more of which may be hydraulically parallel, that conveys the fluid from the formation into a flow bore of the wellbore tubular. A reactive media may be disposed in each of the flow paths. The

reactive media may change permeability by interacting with a selected fluid, e.g., water. In some applications, at least two of the flow paths in the in-flow control device may be in a serial arrangement. In embodiments, the reactive media may include a Relative Permeability Modifier. In one non-limiting arrangement, the reactive media may increase a resistance to flow as water content increases in the fluid from the formation and decrease a resistance to flow as water content decreases in the fluid from the formation. The reactive media may be formulated to change a flow parameter such as permeability, tortuosity, turbulence, viscosity, and cross-sectional flow area.

[0041] What has been described includes, in part, a method for controlling a flow of a fluid into a tubular in a wellbore. The method may include conveying the fluid via a plurality of flow paths from the formation into a flow bore of the wellbore tubular; and controlling a resistance to flow in plurality of flow paths using a reactive media disposed in each of the flow paths. Two or more of the flow paths may be hydraulically parallel. In aspects, the method may also include reconfiguring the reactive media *in situ*.

[0042] What has been described includes, in part, a system for controlling a flow of a fluid from a subsurface formation. The system may include a wellbore tubular having a bore that conveys the fluid from the subsurface formation to the surface; an in-flow control device positioned in the wellbore; a hydraulic circuit formed in the in-flow control device that conveys the fluid from the formation into the bore of the wellbore tubular; and a reactive media disposed in the hydraulic circuit that changes permeability by interacting with a selected fluid. The hydraulic circuit may include two or more hydraulically parallel flow paths. In aspects, the system may include a configuration tool that configures the reactive media *in situ*. The hydraulic circuit may include a first set of parallel flow paths in serial alignment with a second set of parallel flow paths.

[0043] Referring now to **Fig. 3**, it should be appreciated that the reactive media may be positioned in places other than the in-flow control device **130**. For example, the flow path **310** may be within the particulate control device **110**, along the channels of the flow management device **120**, or elsewhere along the production control device **100**.

The reactive media used in such locations may be any of those described previously or described below.

[0044] For the sake of clarity and brevity, descriptions of most threaded connections between tubular elements, elastomeric seals, such as o-rings, and other well-understood techniques are omitted in the above description. Further, terms such as "slot," "passages," "conduit," "opening," and "channels" are used in their broadest meaning and are not limited to any particular type or configuration. The foregoing description is directed to particular embodiments of the present disclosure for the purpose of illustration and explanation. It will be apparent, however, to one skilled in the art that many modifications and changes to the embodiment set forth above are possible without departing from the scope of the disclosure.

CLAIMS

What is claimed is:

1. An apparatus for controlling a flow of a fluid into a bore of a wellbore tubular, comprising:

a plurality of flow paths configured to convey the fluid from the formation into the bore of the wellbore tubular, wherein at least two of the flow paths are hydraulically parallel; and

a reactive media disposed in at least two flow paths of the plurality of flow paths, the reactive media being configured to change permeability by interacting with a selected fluid.

2. The apparatus of claim 1 wherein the selected fluid is water.

3. The apparatus of claim 1 wherein at least one flow path of the plurality of flow paths is serially aligned with the at least two hydraulically parallel flow paths.

4. The apparatus of claim 1 further comprising a flow control element, wherein the at least two hydraulically parallel flow paths are formed in the flow control element.

5. The apparatus of claim 1 wherein the reactive media includes a Relative Permeability Modifier.

6. The apparatus of claim 1 wherein the reactive media increases a resistance to flow as water content increases in the fluid from the formation and decreases a resistance to flow as water content decreases in the fluid from the formation.

7. The apparatus of claim 1 wherein the reactive media changes a parameter related to the flow path, the parameter being selected from a group consisting of: (i) permeability, (ii) tortuosity, (iii) turbulence, (iv) viscosity, and (v) cross-sectional flow area.

8. The apparatus of claim 1 further comprising an in-flow control device, wherein the plurality of flow paths are formed in the in-flow control device.

9. A method for controlling a flow of a fluid into a tubular in a wellbore, comprising:
conveying the fluid via a plurality of flow paths from the formation into the wellbore tubular, wherein at least two of the flow paths are hydraulically parallel; and
controlling a resistance to flow in the plurality of flow paths using a reactive media disposed in at least two flow paths of the plurality of flow paths.
10. The method of claim 9 wherein the selected fluid is water.
11. The method of claim 9 further comprising conveying the fluid via at least one flow path that is serially aligned with the at least two hydraulically parallel flow paths.
12. The method of claim 9 further comprising forming the at least two hydraulically parallel flow paths in a flow control element.
13. The method of claim 9 wherein the reactive media includes a Relative Permeability Modifier.
14. The method of claim 9 wherein the reactive media increases a resistance to flow as water content increases in the fluid from the formation and decreases a resistance to flow as water content decreases in the fluid from the formation.
15. The method of claim 9 wherein the reactive media changes a parameter related to the flow path, the parameter being selected from a group consisting of: (i) permeability, (ii) tortuosity, (iii) turbulence, (iv) viscosity, and (v) cross-sectional flow area.
16. The method of claim 9 further comprising reconfiguring the reactive media *in situ*.
17. A system for controlling a flow of a fluid from a subsurface formation, comprising:
a wellbore tubular having a bore configured to convey the fluid from the subsurface formation to the surface;
an in-flow control device positioned in the wellbore and along the wellbore tubular;

a hydraulic circuit formed in the in-flow control device, the hydraulic circuit being configured to convey the fluid from the formation into the bore of the wellbore tubular, wherein the hydraulic circuit includes at least two hydraulically parallel flow paths; and
a reactive media disposed in the hydraulic circuit, the reactive media being configured to change permeability by interacting with a selected fluid.

18. The system of claim 17 further comprising a configuration tool adapted to be conveyed into the wellbore and configure the reactive media *in situ*.

19. The system of claim 17 wherein the hydraulic circuit includes at least one flow path that is serially aligned with the at least two hydraulically parallel flow paths.

20. The system of claim 17 wherein the reactive media includes a Relative Permeability Modifier.

21. The system of claim 17 wherein the reactive media increases a resistance to flow as water content increases in the fluid from the formation and decreases a resistance to flow as water content decreases in the fluid from the formation.

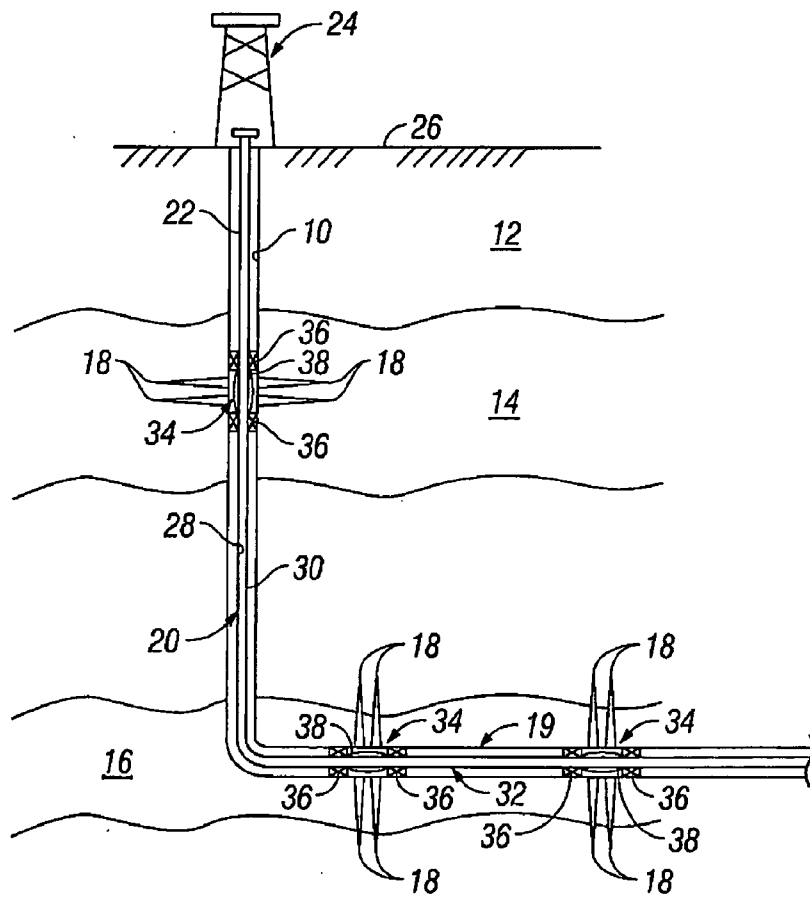

FIG. 1

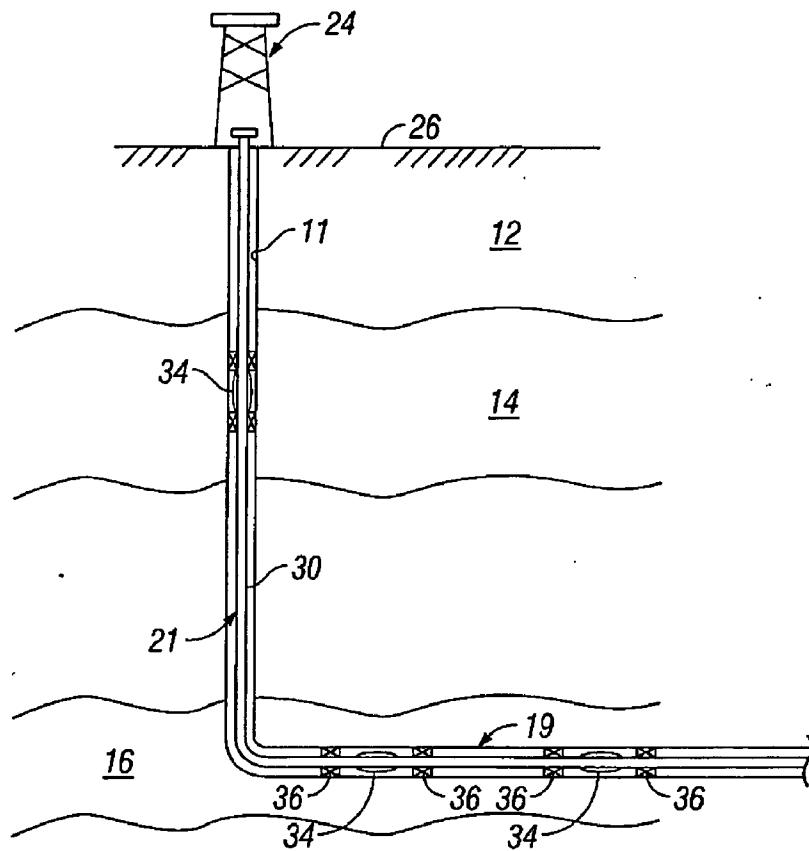

FIG. 2

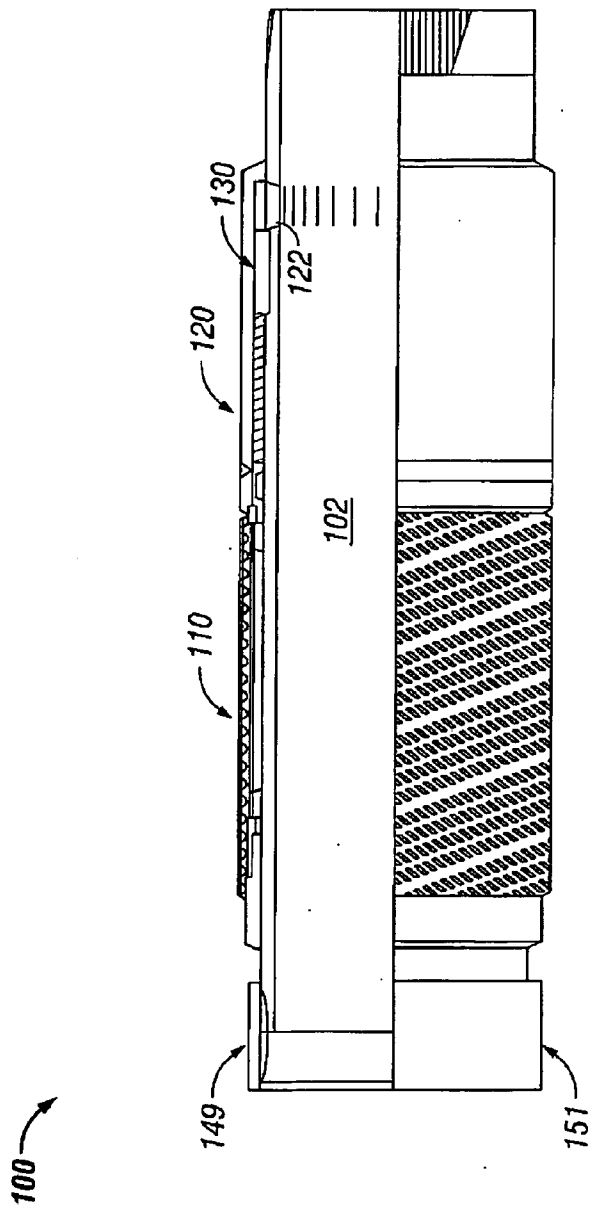

FIG. 3

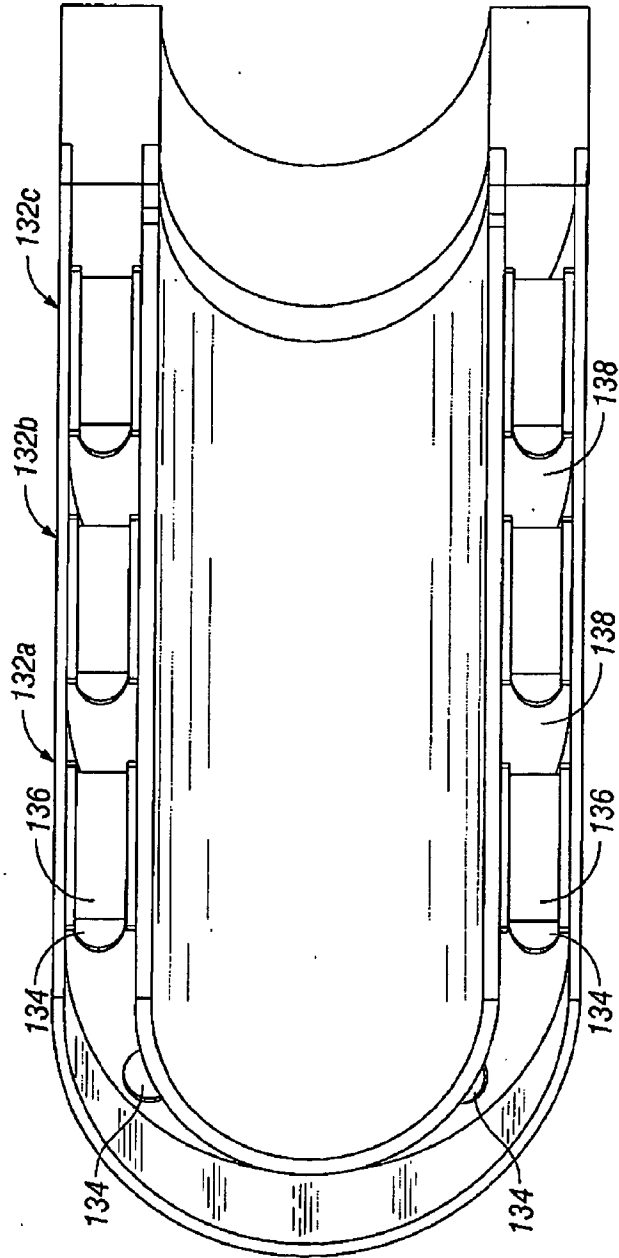

FIG. 4

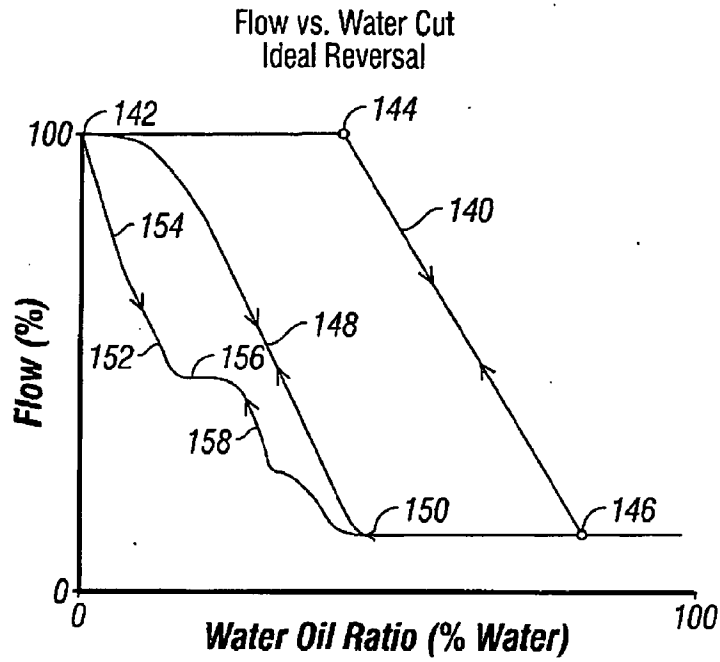

FIG. 5

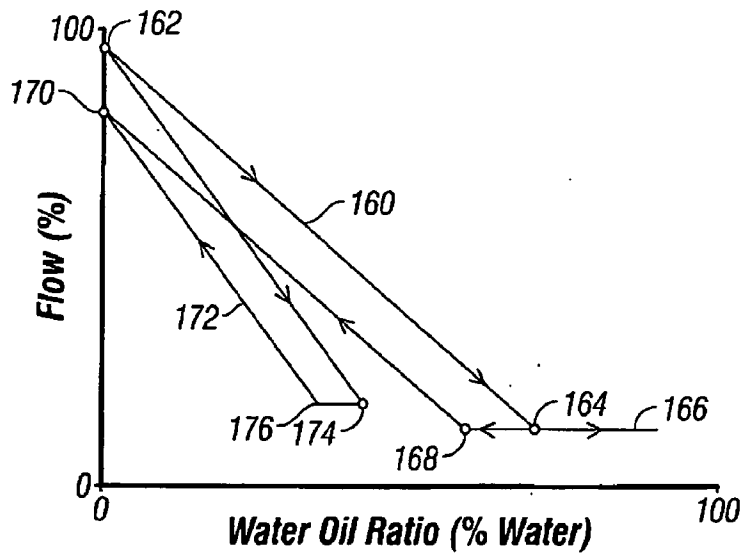

FIG. 6

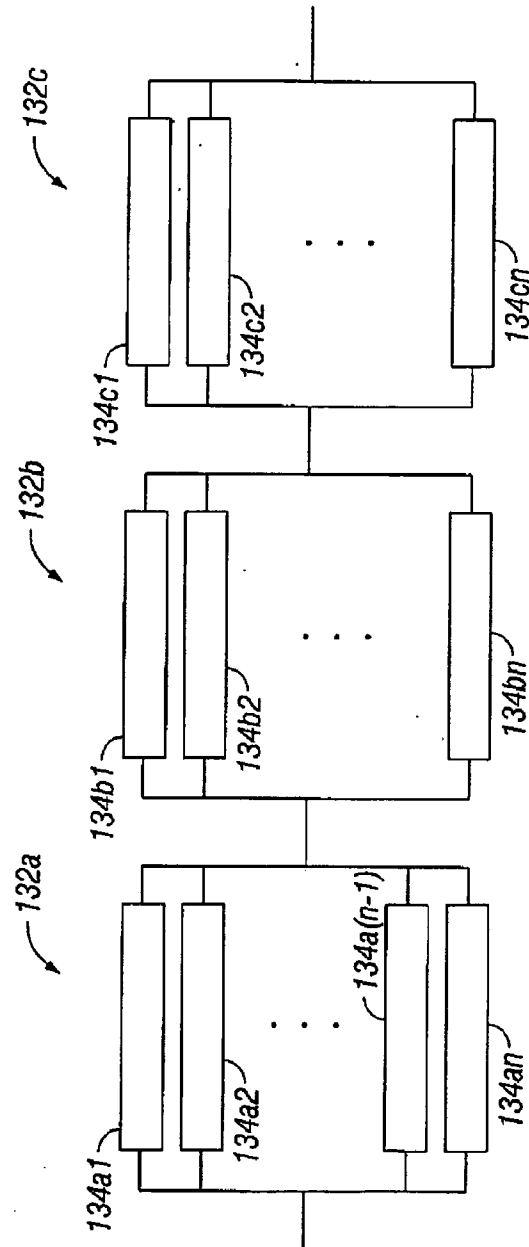

FIG. 7

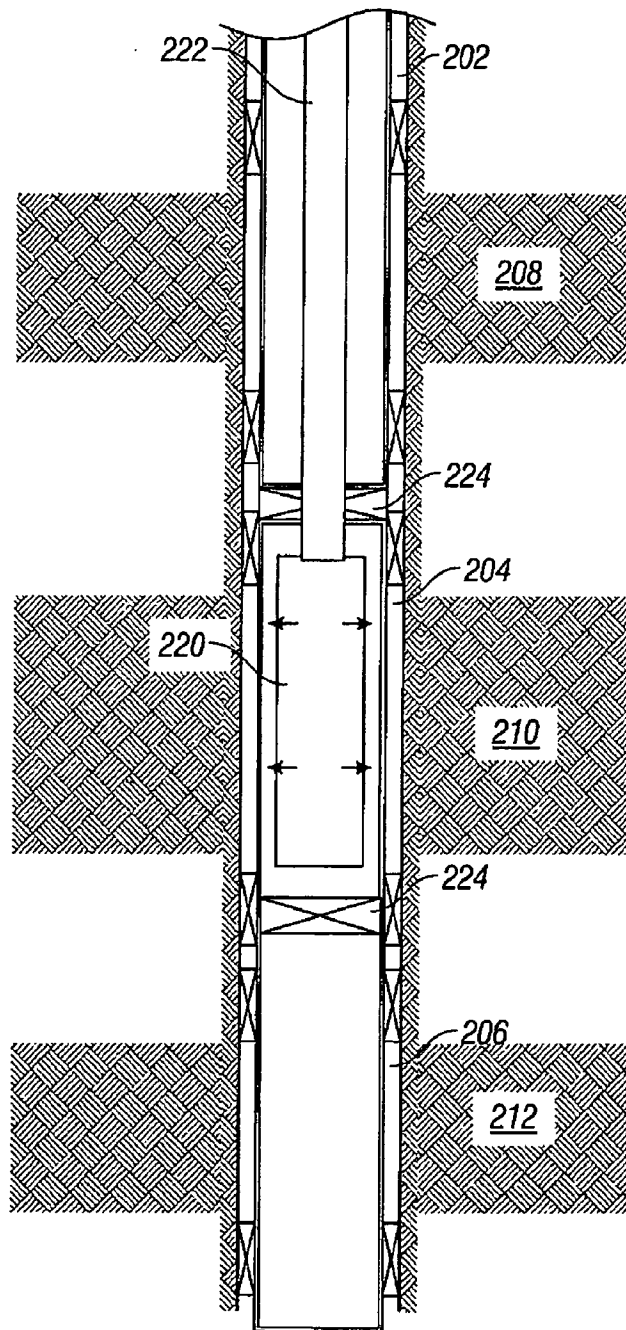

FIG. 8