



(11) **EP 3 375 937 B1**

(12) **EUROPEAN PATENT SPECIFICATION**

(45) Date of publication and mention of the grant of the patent:  
**08.04.2020 Bulletin 2020/15**

(51) Int Cl.:  
**E01H 1/08 (2006.01)**

(21) Application number: **18155486.6**

(22) Date of filing: **07.02.2018**

(54) **ROAD-SWEEPING VEHICLE**

STRASSENKEHRFAHRZEUG

VÉHICULE DE BALAYAGE DE ROUTE

(84) Designated Contracting States:  
**AL AT BE BG CH CY CZ DE DK EE ES FI FR GB GR HR HU IE IS IT LI LT LU LV MC MK MT NL NO PL PT RO RS SE SI SK SM TR**

(30) Priority: **17.03.2017 GB 201704254**

(43) Date of publication of application:  
**19.09.2018 Bulletin 2018/38**

(73) Proprietor: **Stock Sweepers Limited**  
**Mitcheldean, Gloucestershire GL17 0DD (GB)**

(72) Inventors:  
• **STOCK, Mitch**  
**Cinderford, Gloucestershire GL14 2BE (GB)**

• **STOCK, Jeff**  
**Chepstow, Monmouthshire NP16 7EY (GB)**  
• **STOCK, Tom**  
**Chepstow, Monmouthshire NP16 7EY (GB)**

(74) Representative: **Mewburn Ellis LLP**  
**City Tower**  
**40 Basinghall Street**  
**London EC2V 5DE (GB)**

(56) References cited:  
**CN-U- 2 030 622 CN-U- 205 411 088**  
**DE-A1- 2 221 201 GB-A- 191 025 003**  
**US-A- 4 251 241**

**EP 3 375 937 B1**

Note: Within nine months of the publication of the mention of the grant of the European patent in the European Patent Bulletin, any person may give notice to the European Patent Office of opposition to that patent, in accordance with the Implementing Regulations. Notice of opposition shall not be deemed to have been filed until the opposition fee has been paid. (Art. 99(1) European Patent Convention).

**Description**TECHNICAL FIELD

**[0001]** The invention relates to a road-sweeping vehicle.

BACKGROUND

**[0002]** Many kinds of suction-type cleaning vehicles exist for the purpose of cleaning and removing dirt, litter or other debris from an area. For example, road sweeping vehicles are commonly used to clean roads or other paved surfaces. Typically, such vehicles comprise a motorised debris collection mechanism mounted on a vehicle chassis, which is supported on a set of drivable wheels. The debris collection mechanism typically includes both a mechanical sweeping device, such as rotating brushes or the like, and a suction device, which may act to draw material into a collection chamber housed on the vehicle. Sweepers of this type are manufactured, for example, by Johnston Sweepers Limited and Scarab Sweepers Limited, and are well known to a person skilled in the art.

**[0003]** Suction-type cleaning vehicles often also include dust suppression systems for reducing the amount of dust emitted when collecting debris. Typically, the dust suppression system includes a water tank housed on the vehicle and one or more water sprayers for wetting the paved surface before the debris are collected. This reduces the amount of flying dust particles caused by the brushes and forms a mixture of dirt and water on the paved surface. The mixture is then drawn into the collection chamber, where it falls to the bottom of the collection chamber so that fewer dust particles are emitted with the exhaust air.

**[0004]** The present invention arises from the realisation that fine dust particles can be blown out from a cleaning vehicle's debris collection mechanism even when a dust suppression system is used. Such dust suppression systems also present the drawback that they only work for a limited amount of time, as they cease to be effective when the water tank is empty. Furthermore, in certain situations it may be desirable to clean a road or paved surface without wetting it. For example, this is the case before anti-skid road surfacing material is deposited on a road surface, where it is necessary for the road surface to be clean and dry for the material to adhere to the road surface properly.

**[0005]** GB 25,003 discloses a road dust collector in which collected air is directed along a tortuous path above a compartment that contains fluid. The air is forced to impinge on the fluid, which retains fine particles in the air.

**[0006]** US 4,251,241 discloses a dirt separator suited for use with a dry pick-up vacuum cleaner.

**[0007]** DE 2221201 discloses a road sweeper in which a dirt receiving container is partially filled with water, and where the incoming air is guided to below the water sur-

face.

**[0008]** CN 2030622 U discloses a dust-removing road cleaner in which collected dust is filtered in water.

**[0009]** CN 205411088 U discloses a ground sweeping machine in which a plurality of washing spray heads are arranged along the flow path of collected material.

SUMMARY OF THE INVENTION

**[0010]** The present invention provides a road-sweeping vehicle having an independent liquid-based filtration system to remove dust particles from exhaust air. The exhaust air may be from a debris suction mechanism, in which an air flow draws debris into a collection chamber.

**[0011]** The liquid-based filtration system can act as an additional filter to remove dust that gets past the collection chamber, so that any dust which was not deposited in the collection chamber is prevented from escaping to the atmosphere. This can greatly reduce the amount of dust present in air emitted from the debris suction mechanism.

**[0012]** One advantage of the liquid-based filtration system does not require the road surface to be wetted in order to function. This enables a road surface to be cleaned without wetting it, whilst still reducing the amount of dust emitted. The liquid-based dust filtration system is self-contained, meaning that its liquid (which is preferably water) is not shared with any other systems on the suction-type cleaning vehicle. The suction-type cleaning vehicle also has a conventional dust suppression system, which has its own dedicated water tank (i.e. the water tank is separate from the liquid-based dust filtration system) and sprayers arranged to wet a surface under the suction-type cleaning vehicle. The suction-type cleaning vehicle of the present invention can suppress dust emission for longer periods of time than conventional suction-type cleaning vehicles, as the water-based dust filtration system remains effective even when the water tank for the conventional dust suppression system has run dry.

**[0013]** According to the invention, there is provided a road sweeping vehicle as set out in claim 1. The road sweeping vehicle comprises: a debris suction mechanism supported on a chassis for generating an air flow path between an inlet suction port and an exhaust port, whereby debris located around the inlet suction port are entrained in the air flow; a collection chamber for receiving the entrained debris, wherein the collecting chamber is located on the air flow path after the inlet suction port; and a liquid-based dust filtration system located on the air flow path after the collection chamber, wherein the liquid-based dust filtration system is arranged to remove dust from air that has flowed through the collection chamber.

**[0014]** The air flow path may be defined by a passage-way, e.g. formed from flexible hosing or the like. The air flow path may be directed into the collection chamber in a manner to permit the entrained debris to drop from the flow of air. This may be achieved in a conventional man-

ner by widening the passageway for the air flow, which reduces its velocity. Alternatively or additionally, a filtering or other separation device may be used. The inlet suction port may comprise a suction nozzle or intake aperture. The inlet suction port may be located immediately rearwardly of a mechanical sweeping device, e.g. a cylindrical brush extending across the underside of the vehicle. One or more circular brushes (known as kerb or gutter brooms) may also be mounted between the front and rear wheels. Alternatively, the inlet suction port may be located on a hose extending from the top or the side of the vehicle.

**[0015]** The air flow path exits the collection chamber via an outlet of the collection chamber and subsequently passes through the liquid-based dust filtration system. The liquid-based dust filtration system may use water as a liquid filter, although use of other liquid may be possible. The liquid-based dust filtration system may be referred to as a water-based dust filtration system herein.

**[0016]** The liquid-based dust filtration system may use any liquid-based filter capable of capturing dust and debris from the air flow such that the captured dust and debris remain in liquid contained in the filter. After passing through the liquid-based dust filtration system, the air flow path exits the debris suction mechanism via the exhaust port. In this manner, the air expelled from the debris suction mechanism via the exhaust port is clean, any dust or debris having been captured in either the collection chamber or the liquid-based dust filtration system. The volume of liquid in the liquid-based dust filtration system may remain substantially constant over time (as the liquid is not sprayed out or used for another dust suppression system). As the debris suction mechanism is used, the liquid in the liquid-based dust filtration system may become dirty such that the liquid may need to be changed. The liquid-based dust filtration system may include one or more ports for adding and removing liquid and for cleaning.

**[0017]** The debris suction mechanism includes a rotatable fan for causing air to flow along the air flow path. The liquid-based dust filtration system is located on the air flow path downstream of the rotatable fan, e.g. between the fan and the exhaust port. In this configuration, the air inlet of the water-based dust filtration system may be connected to an outlet of the rotatable fan and the air outlet of the water-based dust filtration system may be connected to the exhaust port of the debris suction mechanism. This can make the water-based dust filtration system easy to install on existing conventional debris suction mechanisms, as only the section of the air flow path after the rotatable fan need be modified.

**[0018]** The liquid-based dust filtration system includes a dedicated liquid supply, and an air inlet configured to cause air flowing along the air flow path to mix with liquid from the dedicated liquid supply to remove dust from the air flow.

**[0019]** The dedicated liquid supply comprises a liquid bath for holding a volume of liquid, and the air inlet is

arranged to direct air flowing along the air flow path into engagement with the volume of liquid. The dedicated liquid supply may be a self-contained water bath. Herein "dedicated" or "self-contained" may mean that liquid in the liquid bath is used solely for the purpose of filtering air flowing through the water-based dust filtration system, i.e. it is not shared with any other systems on board the suction-type cleaning vehicle.

**[0020]** The air inlet may be arranged to direct air into the volume of liquid so that air flowing along the air flow path bubbles through the volume of liquid. For example, the air inlet may be a pipe having an opening inside the liquid bath below the liquid level, such that air flowing along the air flow path must pass through liquid in the liquid bath. As the air passes through the liquid it mixes with the liquid, such that dust and other debris carried by the air become wet and are captured in the liquid bath.

**[0021]** In another example, the air inlet may be arranged to direct air on to a top surface of the volume of liquid. The air flowing along the air flow path is thus incident on the surface of the liquid in the liquid bath, which can cause liquid to splash up, thereby thoroughly mixing the air and the liquid such that dust and other debris carried by the air becomes wet and falls down into the liquid bath.

**[0022]** The air inlet may comprise a constriction in a region where air flowing along the air flow path mixes with liquid from the dedicated liquid supply. This arrangement may enable the Venturi effect to be used to enhance the mixing of liquid with the air flow. An aperture in the pipe that is in fluid communication with the volume of liquid may be provided near the constriction. The constriction causes a drop in air pressure in the pipe at the constriction, causing liquid to flow into the pipe through the aperture and mix with the air flow.

**[0023]** The liquid-based dust filtration system comprises an upright column that defines the air flow path for air after it has mixed with liquid from the dedicated liquid supply. The column may be arranged to remove liquid droplets from the air flow and return them to the volume of liquid. The upright column is positioned above the liquid bath, such that any liquid droplets entrained up the column by the air flow fall back down into the liquid bath under their own weight. This avoids liquid droplets and any dust or debris trapped in the liquid droplets from being expelled from the debris suction mechanism. When determining the height of the column, the air flow velocity along the air flow path can be taken into account to ensure that liquid droplets will not reach the top of the column.

**[0024]** The column may comprise a flow deflector arranged to inhibit liquid from the dedicated liquid supply from escaping from the exhaust port. The flow deflector may include one or more baffles and/or a mesh screen. The baffles may provide surfaces inside the column with which the entrained liquid droplets may collide, so that they can then drip back down into the liquid bath. For example, the baffles may be a series of inclined plates disposed inside the column. The mesh screen serves to

capture any entrained liquid droplets or debris, so that they may fall back down into the water bath. The mesh screen can be arranged such that it covers an internal cross-section of the column, such that air passing through the column must pass through the mesh screen.

**[0025]** The debris suction mechanism comprises a water tank, and a spray in fluid communication with the water tank, wherein the spray is arranged to deliver water outside the vehicle in the vicinity of the inlet suction port. The debris suction mechanism may thus be arranged to wet a road surface under the road sweeping vehicle.

**[0026]** The water tank is independent of the liquid-based dust filtration system. The spray may be selectively operable. The spray may thus be separate from the liquid-based dust filtration system, and can be used on its own or in combination with the liquid-based dust filtration system. By spraying water from the water tank onto the road surface, any dust or debris on the road surface will become wet and so will not form a dust cloud when they are swept by a sweeping mechanism on the road sweeping vehicle. A water and dirt mixture will thus form on the road surface, which is entrained into the collection chamber by the debris suction mechanism. As the water-based dust filtration system works independently from the dust suppression system, it can reduce the amount of dust emitted by the debris suction mechanism even when the debris suction mechanism is turned off (i.e. when water is not sprayed from the water tank via the sprayers). This enables the suction-type cleaning vehicle of the invention to be used in situations where it is desirable to keep the road surface dry.

#### BRIEF DESCRIPTION OF THE DRAWINGS

**[0027]** An embodiment of the invention is discussed below in more detail with reference to the accompanying drawings, in which:

Fig. 1 is a schematic side view of a suction-type cleaning vehicle that is an embodiment of the invention;

Fig. 2 is a schematic side view of a water-based dust filtration system that can be used in a suction-type cleaning vehicle according to the invention;

Fig. 3 is a schematic side view of another water-based dust filtration system that can be used in a suction-type cleaning vehicle according to the invention; and

Fig. 4 is a schematic side view of another water-based dust filtration system which can be used in a suction-type cleaning vehicle according to the invention.

#### DETAILED DESCRIPTION; FURTHER OPTIONS AND PREFERENCES

**[0028]** Fig. 1 shows a side view of a suction-type cleaning vehicle 100 that is an embodiment of the invention.

The suction-type cleaning vehicle 100 is a road sweeping vehicle designed to remove dirt litter or debris from a road or paved surface. The suction-type cleaning vehicle 100 comprises a chassis 102 supported by a pair of front wheels 104 and a pair of rear wheels 106. A driver cabin 108 is mounted on the chassis 102 over the front wheels 104. The vehicle engine (not shown) is located under the driver cabin 108 and has an engine exhaust 110 mounted on the chassis 102 behind the driver cabin 108. Mounted on the chassis behind the engine exhaust 110 and driver cabin 108 is a container 112, which may be an airtight container, which contains a debris suction mechanism 114. To assist a description of the debris suction mechanism, the container 112 is made transparent in Fig. 1. In normal use the debris suction mechanism 114 would not be visible in use.

**[0029]** The debris suction mechanism 114 comprises a fan that is rotatable in fan housing 116 under the action of an auxiliary engine and gearbox (not shown). In operation, the fan creates an air flow (indicated by arrows 118) through a passageway 120 inside the container 112 which draws air in from an inlet suction port 122 mounted on the chassis 102 between the front wheels 104 and rear wheels 106. The inlet suction port 122 may be an opening at the end of a flexible hose 124. The inlet suction port 122 is positioned behind (i.e. closer to the rear wheels 106 than) a mechanical sweeping mechanism 126 for disturbing debris on the road surface so that it is picked up in the air flow sucked into the inlet suction port 122. In this embodiment, the mechanical sweeping mechanism 126 includes a rotatable gutter broom 128 and a cylindrical brush 130.

**[0030]** The air flow from the inlet suction port 122 travels through the passageway 120 to a collection chamber 132 in the container 112. The passageway 120 widens into the collection chamber 132, which may encourage the debris entrained in the air flow to be deposited. Alternatively or additionally a filter (not shown) may be mounted in or at the entrance to the collection chamber 132, as is conventionally known. The fan housing 116 includes an annular air flow passage which circulates the air flow from a central entrance inlet 134 connected to receive air from the passageway 120 to an outlet 136.

**[0031]** The suction-type cleaning vehicle 100 also includes a dust suppression system having a water tank 160 and sprayer 161. The sprayer 161 is a bar of sprayers disposed behind the front wheels 104. The sprayer 161 is connected to the water tank 160 by a pipe (not shown), so that water from the water tank can be sprayed onto a paved surface in front of the sweeping mechanism 126 in order to wet it. In this manner, dust and debris present on the paved surface become wet, and do not create a dust cloud when they are swept by the mechanical sweeping mechanism 126.

**[0032]** The suction-type cleaning vehicle 100 shown in Fig. 1 includes a liquid-based (e.g. water-based) dust filtration system 141 connected between an outlet 136 of the fan housing 116 and an exhaust port 140 on the

roof of the vehicle 100. In this manner, air that has flowed through the collection chamber 132 must flow through the water-based dust filtration system 141 before it exits the debris suction mechanism 114 via the exhaust port 140. The water-based dust filtration system is self-contained. For example, it has a dedicated water bath (not shown in Fig. 1) that is separate from the water tank 160. The water-based dust filtration system is designed to capture dust and debris carried by the air flow which were not deposited in the collection chamber 132, so that air expelled from the exhaust port 140 is clean. The water-based dust filtration system typically operates by directing exhaust air from the fan through a dedicated liquid filter, which may be in the form of a water bath through which the exhaust air is bubbled or air-based droplets. The liquid filter (which is preferably water) attracts and retains particles (e.g. dust particles) carried by the exhaust air. The water-based dust filtration system is configured to prevent the liquid filter from escaping through the exhaust port 140 so that the particles are retained.

**[0033]** Figs. 2-4 show examples of different liquid-based (e.g. water-based) dust filtration systems 141 which could be used in a suction-type cleaning vehicle of the invention, such as vehicle 100 shown in Fig. 1. In each case, the water-based dust filtration system 141 has an air inlet 142 which is connected to the outlet 136 of the fan housing 116. At the lower end of the water-based dust filtration system 141 there is a water bath 143 containing water 144. Above the water bath 143 there is a hollow column 145 which is connected at its upper end to the exhaust port 140. Inside the column are disposed a series of inclined baffles 146.

**[0034]** In the water-based dust filtration system 141 shown in Fig. 2, the air inlet 142 includes a side wall 147 for deflecting the air flow from the outlet 136 of the fan housing 116 towards the surface of the water 144, as shown by arrow 148. This causes the water to splash up and mix with the air, so that any dust or debris carried by the airflow become wet and fall down into the water 144. In some cases the air flow may be particularly strong, such that water droplets (which could contain dust or debris) are entrained up the column 145 towards the exhaust port 140. The inclined baffles 146 cause the air flow to zig-zag as it climbs the column, as shown by arrows 149. As the air flow zig-zags, water droplets entrained in the air flow will collide with the baffles 146 or the inner wall of the column 145 and will not reach the exhaust port 140. As the baffles 146 are inclined, the water droplets will flow downwards and drip back into the water bath 143.

**[0035]** In the water-based filtration system shown in Fig. 3, the air inlet 142 includes a side wall 153 that forms an air passage having an opening below the surface of the water 144 in the water bath 143, such that the air flow must pass through the water 144. In this way, as the air bubbles through the water, the air and water become thoroughly mixed so that dust and debris carried by the air flow become wet and are retained in the water bath.

Passing the air through the water can achieve a high filtering efficiency. The column 145 and baffles 146 shown in Fig. 3 serve the same purpose as those discussed above in relation to Fig. 2.

**[0036]** In the water-based dust filtration system shown in Fig. 4, the air inlet 142 includes a pipe 150 which extends below the surface of the water 144 in the water bath 143. The pipe 150 includes a section 151 with a reduced diameter so as to form a constriction for the air flow. Other forms of constriction can also be used. Section 151 of the pipe 150 includes an aperture on its side wall to the water bath 143. The mixture of air and water in this case is enhanced due to the Venturi effect. As air flows through the constriction in the pipe 150, there is a reduction in air pressure near the aperture causing water to flow into the pipe 150 through the aperture and mix with the air flow, as shown by the arrow 152. The water and air mix in the pipe 150 until they are expelled from the end of the pipe 150 into the water bath 143. The end of the pipe 150 may be situated either above or below the water level of the water bath 143. If the end of the pipe is situated above the water level of the water bath 143, water will be sprayed upwards into the column 145 where it is caught by the baffles 146 and side walls of the column 145. Through the mixing of water with the air flow, dust and debris carried by the air flow will become wet and remain captured in the water bath 143. The column 145 and baffles 146 shown in Fig. 4 serve the same purpose as those discussed above in relation to Fig. 2.

**[0037]** Advantageously, the suction-type cleaning vehicle 100 can operate in either a "dry" mode or a "wet" mode. In the "dry" mode, the dust suppression system is not used, i.e. water is not sprayed from the water tank 160 onto the paved surface. The paved surface can therefore remain dry whilst the suction-type cleaning vehicle 100 cleans the paved surface. Dust and debris present on the paved surface are swept by the sweeping mechanism 126 and then entrained along the air flow path as described above. Dust and debris are filtered out of the air flow by the water-based dust filtration system 141, such that air expelled from exhaust port 140 is clean. This enables the suction-type cleaning vehicle of the invention to be used in situations where it is desirable to keep the paved surface dry. In the "wet" mode, the dust suppression system is used in its usual way. The combination of both the dust suppression system and the water-based dust filtration system can greatly reduce the amount of dust produced when cleaning a paved surface compared to conventional suction-type cleaning vehicles.

## Claims

1. A road-sweeping vehicle (100) comprising:
  - a debris suction mechanism (114) supported on a chassis (102) for generating an air flow path

(118) between an inlet suction port (122) and an exhaust port, wherein the debris suction mechanism includes a rotatable fan for causing air to flow along the air flow path, whereby debris located around the inlet suction port are entrained in the air flow path;  
 a collection chamber (132) for receiving the entrained debris, wherein the collection chamber is located on the air flow path after the inlet suction port; and  
 a liquid-based dust filtration system (141) located on the air flow path after the collection chamber and downstream of the rotatable fan, wherein the liquid-based dust filtration system includes:

a liquid bath (143) for holding a volume of liquid;  
 an air inlet (142) configured to cause air flowing along the air flow path to mix with liquid in the liquid bath to remove dust from air that has flowed through the collection chamber; and  
 an upright column (145) arranged above the liquid bath to define the air flow path for air after it has mixed with liquid in the liquid bath,

**characterized in that** the debris suction mechanism comprises a water tank (160) and a spray (161) in fluid communication with the water tank, wherein the spray is arranged to deliver water in the vicinity of the inlet suction port, and wherein the water tank is independent of the liquid-based dust filtration system.

2. A road sweeping vehicle according to claim 1, wherein the air inlet directs air into the volume of liquid so that air flowing along the air flow path bubbles through the volume of liquid.
3. A road sweeping vehicle according to claim 1, wherein the air inlet directs air on to a top surface of the volume of liquid.
4. A road sweeping vehicle according to any one of claims 1 to 3, wherein the air inlet comprises a constriction in a region where air flowing along the air flow path mixes with liquid from the dedicated liquid supply.
5. A road sweeping vehicle according to any of claims 1 to 4, wherein the upright column comprises a flow deflector arranged to inhibit liquid from the dedicated liquid supply from escaping from the exhaust port.
6. A road sweeping vehicle according to claim 5, wherein the flow deflector includes one or more baffles

(146).

7. A road sweeping vehicle according to claim 5 or 6, wherein the flow deflector includes a mesh screen.
8. A road sweeping vehicle according to any preceding claim, wherein the liquid-based dust filtration system uses water as the liquid.
9. A road sweeping vehicle according to any preceding claim, where the spray is selectively operable.

#### Patentansprüche

1. Straßenkehrfahrzeug (100), das Folgendes umfasst:

einen Schmutzansaugmechanismus (114), der auf einem Fahrgestell (102) getragen wird, um einen Luftstromweg (118) zwischen einer Einlass-Ansaugöffnung (122) und einer Auslassöffnung zu erzeugen, wobei der Schmutzansaugmechanismus ein drehbares Gebläse umfasst, um zu bewirken, dass Luft entlang des Luftstromweges strömt, wobei der Schmutz, der rund um die Einlass-Ansaugöffnung angeordnet ist, im Luftstromweg mitgerissen wird;  
 eine Sammelkammer (132) zum Aufnehmen des mitgerissenen Schmutzes, wobei die Sammelkammer auf dem Luftstromweg hinter der Einlass-Ansaugöffnung angeordnet ist; und  
 ein Staubfiltrationssystem auf Flüssigkeitsbasis (141), das auf dem Luftstromweg hinter der Sammelkammer und stromab des drehbaren Gebläses angeordnet ist, wobei das Staubfiltrationssystem auf Flüssigkeitsbasis Folgendes umfasst:

ein Flüssigkeitsbad (143) zum Aufnehmen eines Flüssigkeitsvolumens;  
 einen Lufteinlass (142), der konfiguriert ist, um zu bewirken, dass Luft entlang des Luftstromweges strömt, um sich im Flüssigkeitsbad mit der Flüssigkeit zu mischen, um den Staub aus der Luft, die durch die Sammelkammer strömt, zu entfernen; und  
 eine aufrechte Säule (145), die oberhalb des Flüssigkeitsbades angeordnet ist, um den Luftstromweg für die Luft zu definieren, nachdem diese sich im Flüssigkeitsbad mit der Flüssigkeit gemischt hat,

#### **dadurch gekennzeichnet, dass**

der Schmutzansaugmechanismus einen Wassertank (160) und einen Zerstäuber (161) in Fluidkommunikation mit dem Wassertank umfasst, wobei der Zerstäuber angeordnet ist, um Was-

ser in der Nähe der Einlass-Ansaugöffnung zu-  
zuführen, und  
wobei der Wassertank von dem Staubfiltrations-  
system auf Flüssigkeitsbasis unabhängig ist.

2. Straßenkehrfahrzeug nach Anspruch 1, wobei der Lufteinlass Luft in das Flüssigkeitsvolumen leitet, so-  
dass Luft, die entlang des Luftstromweges strömt,  
durch das Flüssigkeitsvolumen perlt.
3. Straßenkehrfahrzeug nach Anspruch 1, wobei der Lufteinlass Luft auf eine Oberfläche des Flüssig-  
keitsvolumens lenkt.
4. Straßenkehrfahrzeug nach einem der Ansprüche 1  
bis 3, wobei der Lufteinlass eine Verengung in einem  
Bereich umfasst, in dem sich Luft, die entlang des  
Luftstromweges strömt, mit Flüssigkeit von der zu-  
gehörigen Flüssigkeitszufuhr mischt.
5. Straßenkehrfahrzeug nach einem der Ansprüche 1  
bis 4, wobei die aufrechte Säule ein Strömungsab-  
lenkelement umfasst, das angeordnet ist, um zu ver-  
hindern, dass Flüssigkeit von der zugehörigen Flüs-  
sigkeitszufuhr aus der Auslassöffnung austritt.
6. Straßenkehrfahrzeug nach Anspruch 5, wobei das  
Strömungsablenkelement eine oder mehrere Ab-  
lenkplatten (146) umfasst.
7. Straßenkehrfahrzeug nach Anspruch 5 oder 6, wo-  
bei das Strömungsablenkelement ein Maschensieb  
umfasst.
8. Straßenkehrfahrzeug nach einem der vorangegan-  
genen Ansprüche, wobei das Staubfiltrationssystem  
auf Flüssigkeitsbasis Wasser als Flüssigkeit ver-  
wendet.
9. Straßenkehrfahrzeug nach einem der vorangegan-  
genen Ansprüche, wobei der Zerstäuber selektiv be-  
tätigbar ist.

#### Revendications

1. Véhicule de balayage de route (100) comprenant :

un mécanisme d'aspiration de débris (114) sup-  
porté sur un châssis (102) pour générer un trajet  
d'écoulement d'air (118) entre un orifice d'aspi-  
ration d'entrée (122) et un orifice d'échappe-  
ment, dans lequel le mécanisme d'aspiration de  
débris comprend un ventilateur rotatif pour ame-  
ner de l'air à circuler le long du trajet d'écoule-  
ment d'air, de telle sorte que des débris situés  
autour de l'orifice d'aspiration d'entrée sont en-  
traînés dans le trajet d'écoulement d'air ;

une chambre de collecte (132) pour recevoir les  
débris entraînés, dans lequel la chambre de col-  
lecte est située sur le trajet d'écoulement d'air  
après l'orifice d'aspiration d'entrée ; et  
un système de filtration de poussière à base de  
liquide (141) situé sur le trajet d'écoulement d'air  
après la chambre de collecte et en aval du ven-  
tilateur rotatif, dans lequel le système de filtra-  
tion de poussière à base de liquide comprend :

un bain de liquide (143) pour contenir un  
volume de liquide ;  
une entrée d'air (142) configurée pour ame-  
ner l'air circulant le long du trajet d'écoule-  
ment d'air à se mélanger avec du liquide  
dans le bain de liquide afin d'éliminer la  
poussière depuis l'air qui a circulé à travers  
la chambre de collecte ; et  
une colonne verticale (145) disposée au-  
dessus du bain de liquide pour définir le tra-  
jet d'écoulement d'air pour de l'air après son  
mélange avec du liquide dans le bain de  
liquide,

#### caractérisé en ce que

le mécanisme d'aspiration de débris comprend  
un réservoir d'eau (160) et un pulvérisateur  
(161) en communication fluïdique avec le réser-  
voir d'eau,  
dans lequel le pulvérisateur est agencé pour dé-  
livrer de l'eau à proximité de l'orifice d'aspiration  
d'entrée, et  
dans lequel le réservoir d'eau est indépendant  
du système de filtration de poussière à base de  
liquide.

2. Véhicule de balayage de route selon la revendication  
1, dans lequel l'entrée d'air dirige l'air dans le volume  
de liquide de sorte que de l'air circulant le long du  
trajet d'écoulement d'air bouillonne à travers le vo-  
lume de liquide.
3. Véhicule de balayage de route selon la revendication  
1, dans lequel l'entrée d'air dirige de l'air jusque sur  
une surface supérieure du volume de liquide.
4. Véhicule de balayage de route selon l'une quelcon-  
que des revendications 1 à 3, dans lequel l'entrée  
d'air comprend un rétrécissement dans une zone où  
de l'air circulant le long du trajet d'écoulement d'air  
se mélange avec du liquide provenant de l'alimen-  
tation en liquide dédiée.
5. Véhicule de balayage de route selon l'une quelcon-  
que des revendications 1 à 4, dans lequel la colonne  
verticale comprend un déflecteur d'écoulement  
agencé pour empêcher du liquide provenant de l'ali-  
mentation en liquide dédiée de s'échapper depuis

l'orifice d'échappement.

6. Véhicule de balayage de route selon la revendication 5, dans lequel le déflecteur d'écoulement comprend un ou plusieurs déflecteurs (146). 5
7. Véhicule de balayage de route selon la revendication 5 ou 6, dans lequel le déflecteur d'écoulement comprend un tamis à mailles. 10
8. Véhicule de balayage de route selon l'une quelconque des revendications précédentes, dans lequel le système de filtration de poussière à base de liquide utilise de l'eau comme liquide. 15
9. Véhicule de balayage de route selon l'une quelconque des revendications précédentes, dans lequel le pulvérisateur peut être actionné de manière sélective. 20

25

30

35

40

45

50

55

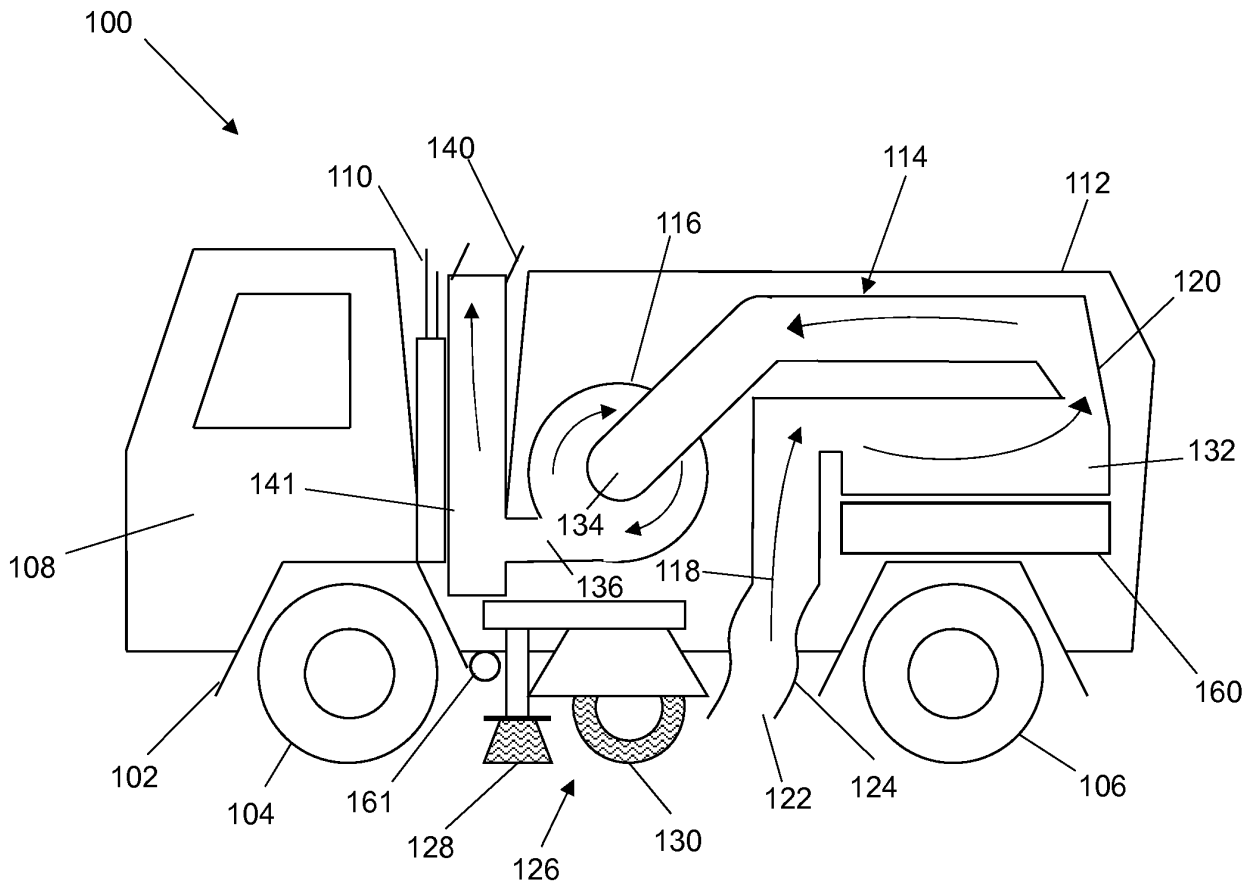

FIG. 1

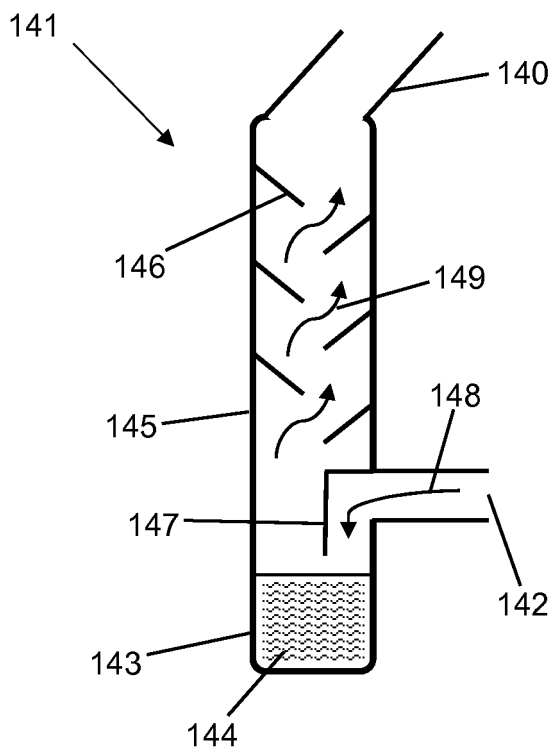

FIG. 2

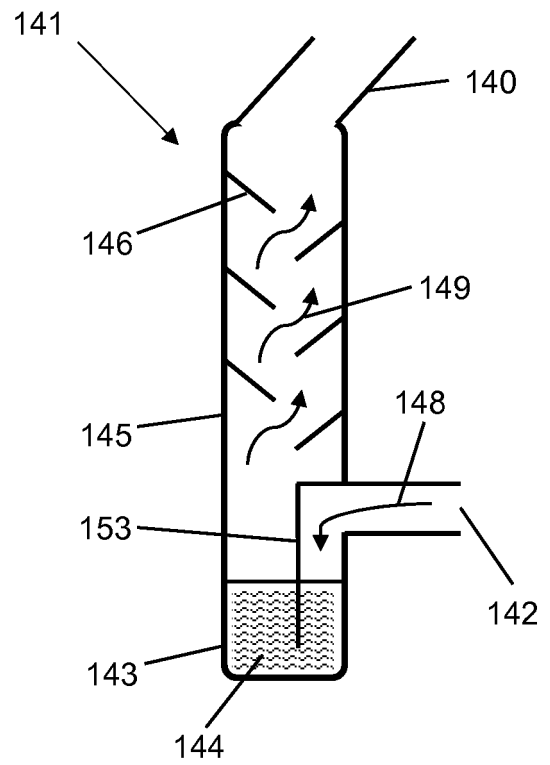

FIG. 3

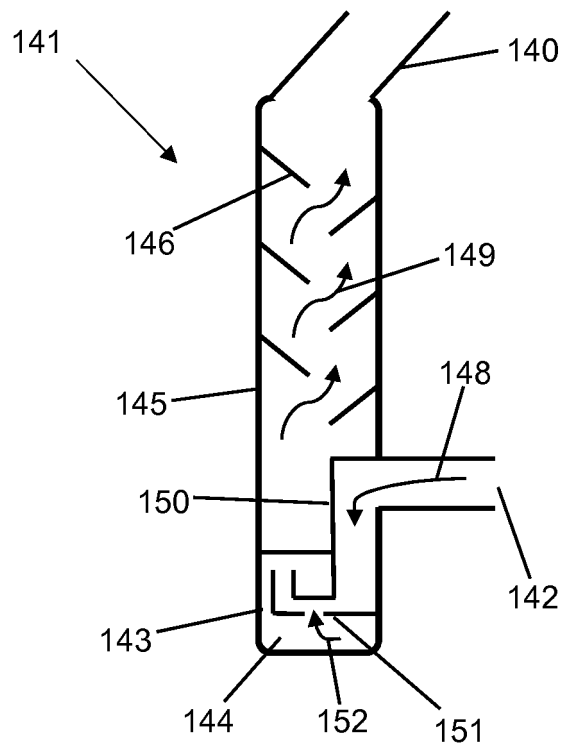

FIG. 4

**REFERENCES CITED IN THE DESCRIPTION**

*This list of references cited by the applicant is for the reader's convenience only. It does not form part of the European patent document. Even though great care has been taken in compiling the references, errors or omissions cannot be excluded and the EPO disclaims all liability in this regard.*

**Patent documents cited in the description**

- GB 25003 A [0005]
- US 4251241 A [0006]
- DE 2221201 [0007]
- CN 2030622 U [0008]
- CN 205411088 U [0009]