

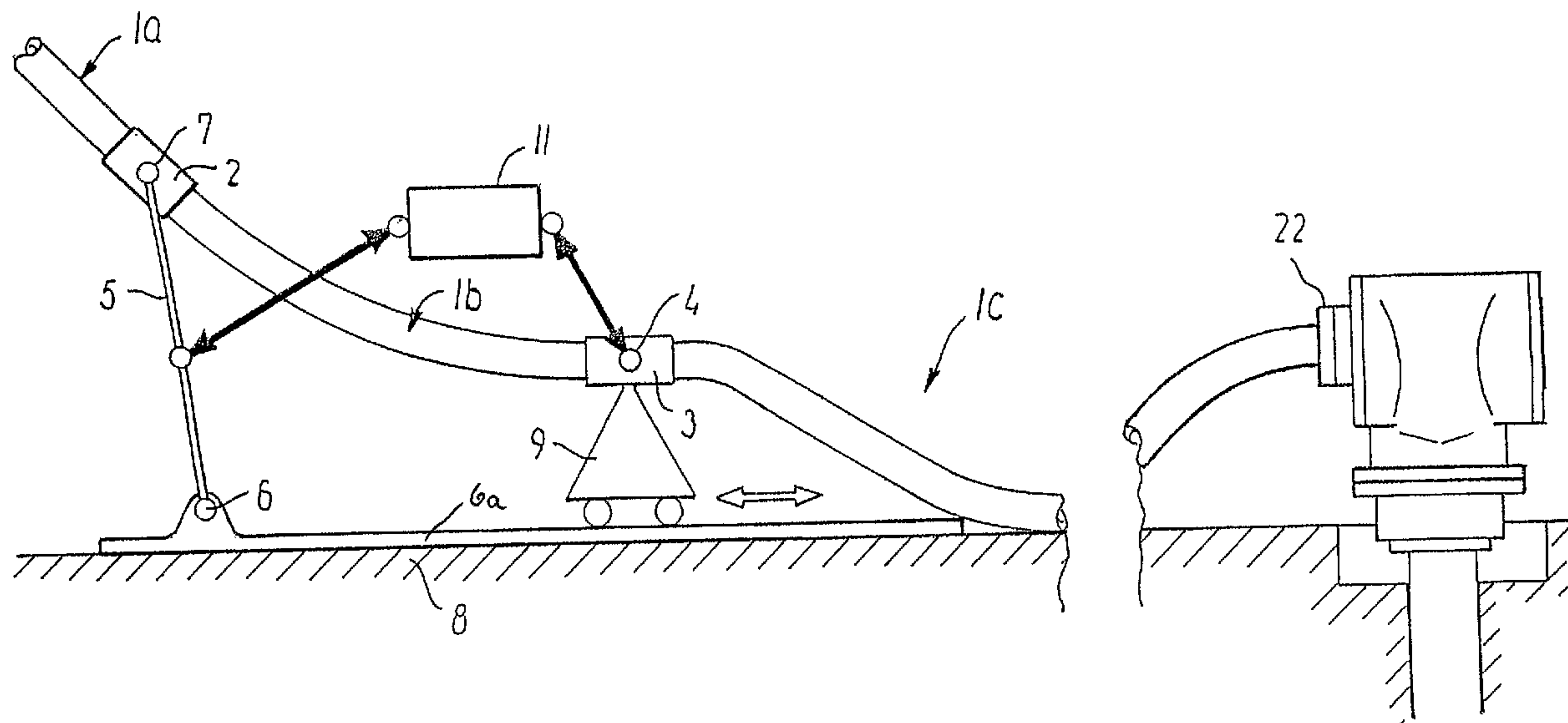

(86) Date de dépôt PCT/PCT Filing Date: 2002/08/05
 (87) Date publication PCT/PCT Publication Date: 2003/02/13
 (45) Date de délivrance/Issue Date: 2010/10/19
 (85) Entrée phase nationale/National Entry: 2004/01/20
 (86) N° demande PCT/PCT Application No.: DK 2002/000524
 (87) N° publication PCT/PCT Publication No.: 2003/012327
 (30) Priorité/Priority: 2001/08/03 (DK PA 2001 01174)

(51) Cl.Int./Int.Cl. *F16L 1/12* (2006.01),
E21B 43/01 (2006.01), *F16L 1/20* (2006.01)
 (72) Inventeur/Inventor:
PEDERSEN, TOMMY, DK
 (73) Propriétaire/Owner:
NKT FLEXIBLES I/S, DK
 (74) Agent: FETHERSTONHAUGH & CO.

(54) Titre : SYSTEME D'ANCRAGE LIMITANT LA FLEXION ET STRUCTURE DE CONDUITE SOUPLE ANCRÉE
 (54) Title: A BENDING-RESTRICTING ANCHORING ARRANGEMENT AND AN ANCHORED FLEXIBLE PIPE
STRUCTURE



(57) **Abrégé/Abstract:**

A bending-restricting anchoring arrangement for anchoring a flexible pipe for the transport of a fluid between a seabed and a sea surface consists of first and second holding sleeves, which, spaced from each other, are adapted to hold a section of the flexible pipe near the seabed. The first holding sleeve is secured via a rigid connecting member to a fixed point on the seabed, while the second holding sleeve is movable in a well-defined manner relative to the first connecting sleeve. In an embodiment, the second holding sleeve is secured to a support movable on the seabed. The first and second holding sleeves are connected to each other by means of a mechanical coupling which may be formed by a plurality of rigid members, which maintain a fixed distance between the holding sleeves and thereby the geometry of the pipe section disposed between the holding sleeves, in several different ways, via connections between the first and second holding sleeves and/or via connections between their respective rigid connecting members. The invention ensures that the forces acting on the flexible pipe because of sea currents, tensile stresses, etc. which occur because of buoyancy when the reinforced pipe is immersed into water, or because of tensile forces that occur because of the use of floating members, are absorbed in the most optimum manner and without any risk of overbending of the section of the pipe between the connection sleeves.

Abstract of the Disclosure:

A bending-restricting anchoring arrangement for anchoring a flexible pipe for the transport of a fluid between a seabed and a sea surface consists of first and second holding sleeves, which, spaced from each other, are adapted to hold a section of the flexible pipe near the seabed. The first holding sleeve is secured via a rigid connecting member to a fixed point on the seabed, while the second holding sleeve is movable in a well-defined manner relative to the first connecting sleeve. In an embodiment, the second holding sleeve is secured to a support movable on the seabed. The first and second holding sleeves are connected to each other by means of a mechanical coupling which may be formed by a plurality of rigid members, which maintain a fixed distance between the holding sleeves and thereby the geometry of the pipe section disposed between the holding sleeves, in several different ways, via connections between the first and second holding sleeves and/or via connections between their respective rigid connecting members. The invention ensures that the forces acting on the flexible pipe because of sea currents, tensile stresses, etc. which occur because of buoyancy when the reinforced pipe is immersed into water, or because of tensile forces that occur because of the use of floating members, are absorbed in the most optimum manner and without any risk of overbending of the section of the pipe between the connection sleeves.

A bending-restricting anchoring arrangement and an anchored flexible pipe structure

The invention relates to a bending-restricting anchoring arrangement for anchoring
5 a flexible pipe between a surface vessel and subsea installation. The pipe can e. g.
be anchored to the seabed or to another fixed structure. The invention also relates
to an anchored flexible structure.

An anchoring arrangement for minimizing overbending of a pipe is known e. g. from
10 US Patent No. 4 906 137. In this anchoring arrangement, all parts of the pipe
disposed between the first anchoring point and a fixed end point must be in the
same plane. In addition, the angle of the part of the pipe, which is positioned in
immediate extension of the first anchoring point and projected on the plane
spanned by the lower part of the pipe between the first anchoring point and the
15 fixed end point, must be within narrow limits. In other words, it must be ensured that
this part of the pipe, when being bent does not result in an overbending of the pipe
between the first anchoring point and the fixed point.

It is thus desirable to provide a bending-restricting anchoring arrangement for
20 anchoring of a flexible pipe wherein the risk of overbending the pipe is reduced or
even avoided.

In accordance with one aspect of the present invention, there is provided a
bending-restricting anchoring arrangement for anchoring of a flexible pipe, the
25 anchoring arrangement comprises a first holding sleeve and a second holding
sleeve spaced from each other, each holding sleeve capable of being secured to
the pipe, the first holding sleeve being pivotally secured via a rigid main connecting
member to a main anchoring unit fixed directly or in a stiff connection to a seabed
to which the pipe is to be anchored, the second holding sleeve being secured to the
30 first holding sleeve via a mechanical coupling, the mechanical coupling ensuring
that any movement provided by the first holding sleeve will be at least partly
transferred to the second holding sleeve, movement of the second holding sleeve

thereby coordinated with movement of the first holding sleeve and thereby movement of the rigid connecting member.

5 In accordance with another aspect of the present invention, there is provided an anchored flexible pipe structure for transport of a fluid between a seabed to a sea surface, comprising a bending-restricting anchoring arrangement as described in the preceding paragraph.

10 In accordance with another aspect of the present invention, there is provided an anchored flexible pipe structure for transport of a fluid between a seabed to a sea surface. The structure comprises a flexible pipe and an anchoring arrangement for anchoring the flexible pipe to the seabed, the anchoring arrangement comprising a first holding sleeve and a second holding sleeve spaced from each other, each holding sleeve being secured to the pipe, the first holding sleeve being pivotally
15 secured via a rigid main connecting member to a main anchoring unit to which the pipe is thereby anchored, the second holding sleeve being secured to the first holding sleeve via a mechanical coupling, the mechanical coupling capable of transferring movements from the first holding sleeve to the second holding sleeve, movement of the second holding sleeve and the rigid main connecting member
20 thereby being coordinated with each other.

In exemplary embodiments, a bending-restricting anchoring arrangement may comprise a first and a second holding sleeve. The holding sleeve may be secured to the pipe at a distance from each other e. g. 0.5-20 or 1-10 meters. The distance
25 can be selected in dependence of the thickness of the pipe, the flexibility of the pipe and the expected bending inducing movement of the pipe. The sleeves may e. g. be adapted to hold a section of the pipe near the seabed. The first holding sleeve is pivotally secured via a rigid main connecting member to a main anchoring unit to which the pipe is to be anchored. The first holding sleeve is thereby secured at a
30 fixed distance to the main anchoring unit. The distance and thereby the length of the main anchoring unit may preferably be between 1 and 19 m, such as between 1 and 10 m. In a preferred embodiment the length of the main anchoring unit is

2a

between 10 and 90 % of the length of the distance between the first and the second sleeves when they are mounted to a pipe. The first sleeve is movable with respect to the main anchoring unit, but the distance is fixed.

5 In one embodiment, the second holding sleeve is secured to the first holding sleeve via a mechanical coupling (11). The mechanical coupling may in principle be any kind of mechanical coupling capable of transferring movements of the first holding sleeve and thereby movements of the rigid main connecting member to the second holding sleeve and visa versa. Thereby the second holding sleeve may be movable
10 in a well-defined manner in relation to the movement to the movement of the main rigid connecting member.

In one embodiment, the second holding sleeve is secured to the first holding sleeve via a mechanical coupling (11) and the main rigid connecting member (5). In this
15 embodiment the mechanical coupling is interposed between the second holding sleeve and the rigid main connecting member. The mechanical coupling may be as above. Thereby the second holding sleeve may be movable in a well-defined manner in relation to the movement to the movement of the main rigid connecting member.

20

Thus, the second holding sleeve may be movable with respect to the main anchoring unit, and the movements is coordinated

with the movement of the rigid connecting member. Thus, an anchoring arrangement has been provided whereby the first and the second holding sleeves being movable with respect to the main anchoring unit, and wherein the movement of the two holding sleeves being coordinated with each other, so that the risk of overbending of the pipe is very small or even practically avoided.

The anchoring unit may e.g. be fixed to the seabed or to another fix point e.g. a subsea structure.

In one embodiment where the pipe has a lower section is adapted to be placed along the seabed, and a upper section leading the pipe to a surface vessel, and the anchoring arrangement is placed or adapted to be placed in its curved transition section, the transition section of the pipe will maintain its curved shape, as forces affecting the first holding sleeve will cause the second holding sleeve to move in a well-defined manner in relation to the first holding sleeve, such that the transition section of the pipe is not subjected to harmful bending forces.

The connections between, respectively, the main connection member to the main anchoring unit and the holding sleeve, as well as other connections, which are connecting connecting members to the respective elements of the anchoring arrangements may in principle be of any type, provided that the pivotally movements as defined in the claims being possibly. In one embodiment one or more of this connection may e.g. be provided with one or more hinge joint, and ball-socket joint

In one embodiment the main rigid connecting member is secured to the main anchoring unit by a hinge joint, said main rigid connecting member (5) preferably being secured to the secured first (2) holding sleeve by a hinge joint.

In one embodiment of the anchoring arrangement according to the invention, the second holding sleeve is connected to the anchoring unit by a sleeve support. The sleeve support should preferably be movable along the anchoring unit. In this embodiment it is preferred that the anchoring unit
5 comprise a protruding floor adapted to be placed on and along the seabed and that the movable support is connected to the protruding floor and is movable along the protruding floor. The sleeve support may e.g. be connected to be movable along a slit. In one embodiment the sleeve support is provided with wheel, and the connection is provided by the
10 weight of the pipe, so that the sleeve support is capable to move along the protruding floor e.g. with an area of the floor limited with a borderline along the protruding floor. In a variation of this embodiment the protruding floor is replaced by a separate floor separated from the anchoring unit but placed with a fixed distance to the anchoring unit.

15

In the above embodiments comprising a sleeve it is ensured that the axial forces provided on the lower part of the pipe is reduced, and thereby the lower part of the pipe may not have to absorb considerable, axial forces.

20 In one embodiment of the invention, the mechanical coupling comprise one secondary rigid connection member, which is pivotally connecting the second holding sleeve to the first holding sleeve or the main rigid connecting member. In this embodiment the second holding sleeve may advantageously be supported by a sleeve support as described above. This
25 structure is relatively easy to implement and thereby relatively cheap.

In one embodiment of the invention, wherein the secondary rigid connection member is connected to the second holding sleeve and to the main rigid connecting member, the connection between the secondary rigid
30 connection member and the main rigid connecting member may be provided at a substantially distance to the connections between the main

rigid connecting member and the anchoring unit. The closer the connection is placed to the first holding sleeve, the more of the movements of the first holding sleeve relative to the main anchoring unit will be transferred to the second holding sleeve. In one embodiment it is desired that the distance of the connection between the secondary rigid connection to the second holding sleeve and the main rigid connecting member to the anchoring unit is at least 10 % such as at least 15 %, such as between 25 and 95 % of the length of the main rigid connecting member between the respective connections to the first holding sleeve and the anchoring unit.

10

In one embodiment of the anchoring arrangement according to the invention the mechanical coupling comprise one or more secondary rigid connection members pivotally connecting the second) holding sleeve to the first holding sleeve or the main rigid connecting member (5). If there is more than one secondary rigid connection members these secondary rigid connection members may e.g. be pivotally connected to each other.

15

In one embodiment where there is more than one secondary rigid connection members pivotally connected to each other, it is desired that the anchoring arrangement, for each connection members more than one, which are pivotally connected to each other and directly connects the second holding sleeve to the first holding sleeve or the main rigid connection member, the mechanical coupling comprises an additional secondary rigid connection member linking the pivotally connected connection members that directly connecting the second holding sleeve to the first holding sleeve or the main rigid connection member, to a fixed point in relation to the main anchoring unit, e.g. to the main anchoring unit or to a secondary anchoring unit fixed to the seabed.

20

25

Thereby it is ensured that a movement provided by the first sleeve will be transferred to the second sleeve.

30

The above embodiment where the mechanical coupling comprises two or more secondary rigid connection members, anchoring arrangements are provided which are suitable in particular where the conditions of the bed are not suitable for supporting a movable support lying on the bed.

5

In one embodiment according to the invention, wherein the mechanical coupling comprise 3 secondary rigid connection members, a second, a third and a fourth rigid members, and wherein the second rigid member is pivotally connected to the first holding sleeve or to the rigid main connecting member, and to the fourth rigid member, and the fourth rigid member further is pivotally connected to the first holding sleeve, the third rigid member is pivotally connecting the connected second and fourth rigid members to an anchoring unit. The anchoring unit may e.g. be the main anchor unit or it may be a secondary anchoring unit, which may or may not be linked to the main anchoring unit. In use the main and the secondary anchoring unit or units should preferably be place with a fixed distance to each other, more preferably the anchoring unit should be fixed in position relative to each other.

20 In this just described embodiment wherein, the second rigid member is pivotally secured to the main rigid connecting member, the connection between the second rigid connection member and the main rigid connecting member may e.g. be provided at a substantially distance to the connection between the main rigid connecting member and the anchoring unit, e.g. at a distance of at least 10 %, such as at least 15 %, such as between 25 and 25 95% or even up to 100 % of the length of the main rigid connecting member between the respective connections to the first holding sleeve and the anchoring unit.

30 The invention also relates to an anchored flexible pipe structure for the transport of a fluid from a seabed to a sea surface, wherein the structure

comprising a bending-restricting anchoring arrangement as described above.

5 In one embodiment the pipe is secured to the seabed between its two ends, a first end of the pipe being in liquid connection with a subsea installation such, as an oil field installation, and a second end of the pipe being in liquid connection with a surface vessel, such as a floating structure e.g. a platform or a ship.

10 The pipe may be any type of pipe e.g. a reinforced flexible pipe.

The invention will now be explained more fully with reference to the embodiments shown in the drawing, in which

15 fig. 1 shows the basic structure of a bending-restricting attachment arrangement according to the invention,

fig. 2 shows a first embodiment of the bending-restricting attachment arrangement according to the invention,

20

figs. 2a, 2b show the embodiment of fig. 2 seen from the left and in two positions,

25 fig. 3a shows a second embodiment of the bending-restricting attachment arrangement according to the invention,

fig. 3b shows a variant of the embodiment of fig. 3a, while

30 fig. 4 shows the bending-restricting attachment arrangement incorporated in an offshore system.

In fig. 1, 1a, 1b, 1c designate three sections of a pipe, e.g. a pipe for use in connection with offshore installations. The pipe has a lower section 1c adapted to be placed along the seabed, and a upper section 1a leading the pipe to a surface vessel, and a curved transition section 1b.

5

A holding sleeve 2 is mounted on the pipe between the sections 1a and 1b, capable of absorbing most of or all the tensile forces that affect it. 5 designates a main rigid connecting member whose one end 7 is secured to the holding sleeve 2, while its other end 6 is secured by means of a hinge to a fixed anchoring unit 6 on a seabed 8.

10

A second attachment sleeve 3 is secured on the pipe between the sections 1b and 1c, and this second attachment sleeve is secured at an attachment point 4 to a movable sleeve support 9.

15

A mechanical coupling 11 is arranged between the holding sleeves 2 and 3, which is shown here as a coupling whose one end is secured (shown symbolically by a black arrow) to the main rigid member 5, while its other end (also shown symbolically by a black arrow) is secured to the second connecting sleeve 3.

20

The arrangement shown in fig. 1 operates in the manner that movements of the main rigid member 5 will result in a movement of the attachment sleeve 3 which may be a rotary or translatory movement or combinations of these.

25

Because of the movement of the attachment sleeve 3 it is desired that the third section 1c of the pipe between the attachment sleeve 3 and a rigid fixation 22 has a certain mobility. In the shown embodiment, the sleeve support is supplied with wheels and is placed on a protruding part 6a of the anchoring unit 6. Several methods may be applied for ensuring this mobility, the preferred method being to place the anchoring unit such that

30

the section 1c of the pipe does have its concave part facing toward the rigid fixation 22 of the pipe.

5 Fig. 2 shows an embodiment of the invention in which the mechanical coupling between the main rigid connecting member 5 and the movable, secondary holding sleeve 3 of the pipe is formed by a further rigid member 14.

10 Figs. 2a and 2b show the structure of fig. 2 seen from the left, where fig. 2a shows a position in which the main rigid member 5 is in a vertical position, while in fig. 2b it is shown with a bend caused by the application of a force. This bend is possible since, as mentioned, the main rigid member 5 is hinged to the bed.

15 Figs. 3a and 3b show two embodiments in which the mechanical coupling between the attachment sleeves 2, 3 includes 3 secondary rigid members 16, 17 and 19.

20 A second rigid member 16 extends from a position 13 on the main rigid member 5 or a position 19 on the first holding sleeve 2, and has its opposite end secured to one end of third 17 and fourth 18 rigid members at a link 14. The other end of the third rigid member is hinged to the seabed at the point 15, while the fourth 18 rigid member is connected to the second holding sleeve 3.

25

30 In fig. 4, the embodiment of the invention of fig. 1 is shown in a setup in which a flexible pipe extends from a vessel 21. As will be seen, the flexible pipe extends in chain line shape from the vessel 21 down to a fixed installation on the seabed. The flexible pipe is provided with buoyancy members 20 in the vicinity of the section 1a of the flexible pipe and in a direction toward the vessel 21, as is known.

Although the invention has been explained in connection with specific embodiments, the mechanical coupling according to the invention may be modified within the scope of the claims. The decisive point is that the holding sleeves are coupled together such that the pipe section 1b cannot be bent unduly.

Finally, it should be noted that although the invention has mainly been explained in connection with subsea installations which are anchored to a seabed, nothing prevents the principles of the invention from being applied in connection with pipes which e.g. connect two floating structures.

What is claimed is:

1. A bending-restricting anchoring arrangement for anchoring of a flexible pipe, said anchoring arrangement comprises a first holding sleeve and a second holding sleeve spaced from each other, each holding sleeve capable of being secured to the pipe, said first holding sleeve being pivotally secured via a rigid main connecting member to a main anchoring unit fixed directly or in a stiff connection to a seabed to which the pipe is to be anchored, said second holding sleeve being secured to the first holding sleeve via a mechanical coupling, said mechanical coupling ensuring that any movement provided by the first holding sleeve will be at least partly transferred to the second holding sleeve, movement of the second holding sleeve thereby coordinated with movement of the first holding sleeve and thereby movement of the rigid main connecting member.
2. The anchoring arrangement according to claim 1, wherein the mechanical coupling is connected to the rigid main connecting member.
3. The anchoring arrangement according to any one of claims 1 and 2, wherein the rigid main connecting member is secured to the main anchoring unit by a hinge joint.
4. The anchoring arrangement according to claim 3, wherein said rigid main connecting member is secured to the first holding sleeve by a hinge joint.
5. The anchoring arrangement according to any one of claims 1 to 4, wherein the second holding sleeve is connected to the anchoring unit by a sleeve support, said sleeve support being movable along the main anchoring unit.
6. The anchoring arrangement according to claim 5, wherein said main anchoring unit comprises a protruding floor adapted to be placed on and along the seabed, said movable support being connected to the protruding floor and being movable along the protruding floor.
7. The anchoring arrangement according to any one of claims 1 to 6, wherein the mechanical coupling comprises one or more secondary rigid connection

members pivotally connecting the second holding sleeve to the first holding sleeve or the rigid main connecting member.

8. The anchoring arrangement according to claim 7, wherein said secondary rigid connection members if more than one, are pivotally connected to each other.
9. The anchoring arrangement according to claim 7, wherein the mechanical coupling comprises one secondary rigid connection member pivotally connecting the second holding sleeve to the first holding sleeve or the rigid main connecting member.
10. The anchoring arrangement according to claim 9, wherein said secondary rigid connection member is connected to the second holding sleeve and to the rigid main connecting member, a connection of the secondary rigid connection member to the rigid main connecting member being at a substantial distance to a connection between the rigid main connecting member and the main anchoring unit, wherein a substantial distance means at least 10% of the length of the rigid main connecting member between respective connections to the first holding sleeve and the main anchoring unit.
11. The anchoring arrangement according to any one of the claims 1 to 8, wherein the mechanical coupling comprises 3 secondary rigid connection members, a second, a third and a fourth rigid members, wherein the second rigid member is pivotally connected to the first holding sleeve or the rigid main connecting member, and to the fourth rigid member, the fourth rigid member further being pivotally connected to the first holding sleeve, the third rigid member pivotally connecting the connected second and fourth rigid members to an anchoring unit.
12. The anchoring arrangement according to claim 11, wherein said anchoring unit is a secondary anchoring unit.
13. The anchoring arrangement according to any one of claims 11 and 12, wherein the second rigid member is pivotally secured to the rigid main connecting member, at a substantial distance to a connection between the rigid main connecting member and the main anchoring unit, wherein the

substantial distance means at least 10% of the length of the rigid main connecting member between respective connections to the first holding sleeve and the main anchoring unit.

14. An anchored flexible pipe structure for transport of a fluid between a seabed to a sea surface, comprising a bending-restricting anchoring arrangement according to any one of claims 1 to 13.
15. An anchored flexible pipe structure for transport of a fluid between a seabed to a sea surface, said structure comprising a flexible pipe and an anchoring arrangement for anchoring the flexible pipe to the seabed, said anchoring arrangement comprising a first holding sleeve and a second holding sleeve spaced from each other, each holding sleeve being secured to the pipe, said first holding sleeve being pivotally secured via a rigid main connecting member to a main anchoring unit to which the pipe is thereby anchored, said second holding sleeve being secured to the first holding sleeve via a mechanical coupling, said mechanical coupling capable of transferring movements from the first holding sleeve to the second holding sleeve, movement of the second holding sleeve and the rigid main connecting member thereby being coordinated with each other.
16. The anchored flexible pipe structure according to claim 15, wherein said anchoring arrangement is as defined in any one of claims 2 to 13.
17. The anchored flexible pipe structure according to any one of claims 15 and 16, wherein the pipe is secured to the seabed between first and second ends of the pipe, the first end of the pipe being in liquid connection with a subsea installation, and the second end of the pipe being in liquid connection with a surface vessel.
18. The anchored flexible pipe structure according to claim 17, wherein the surface vessel is a floating structure.

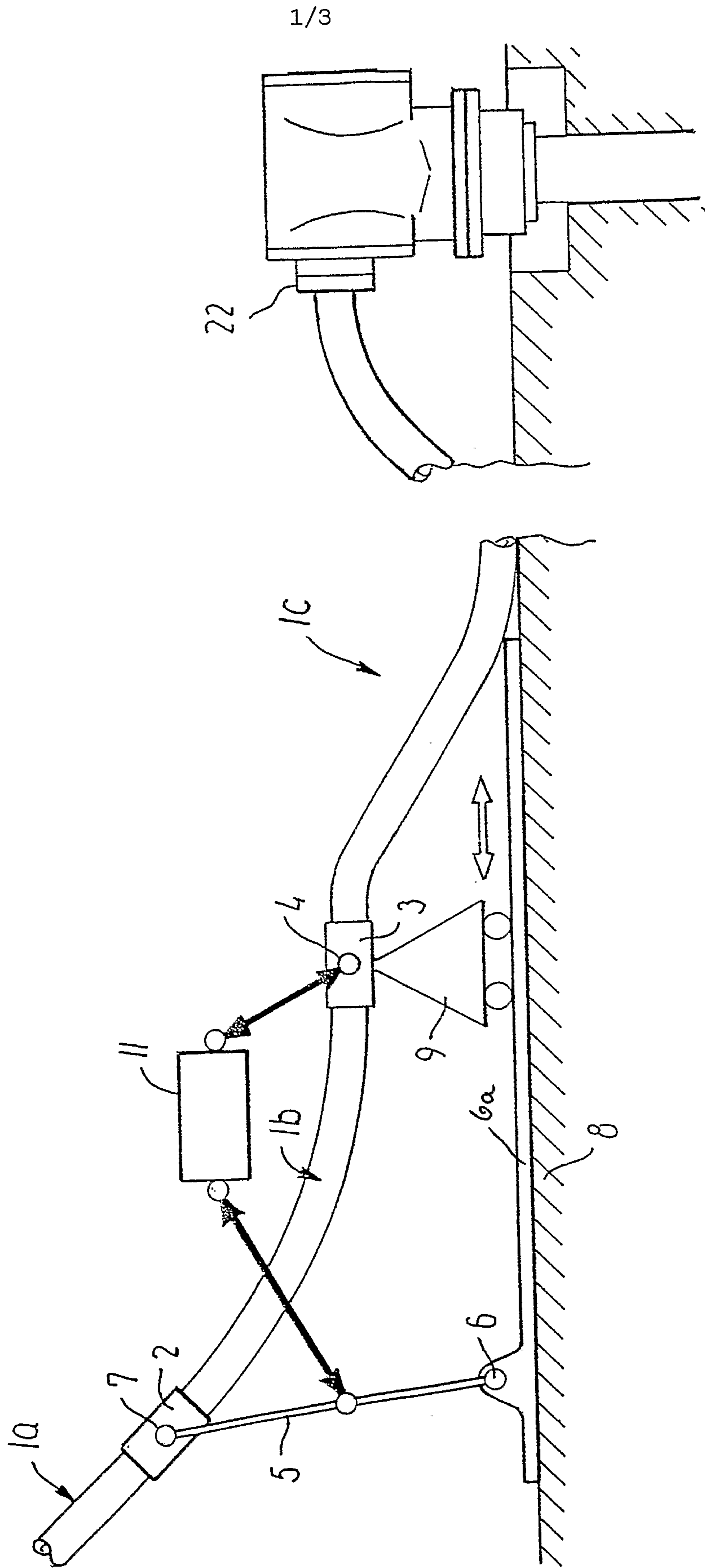

FIG.1

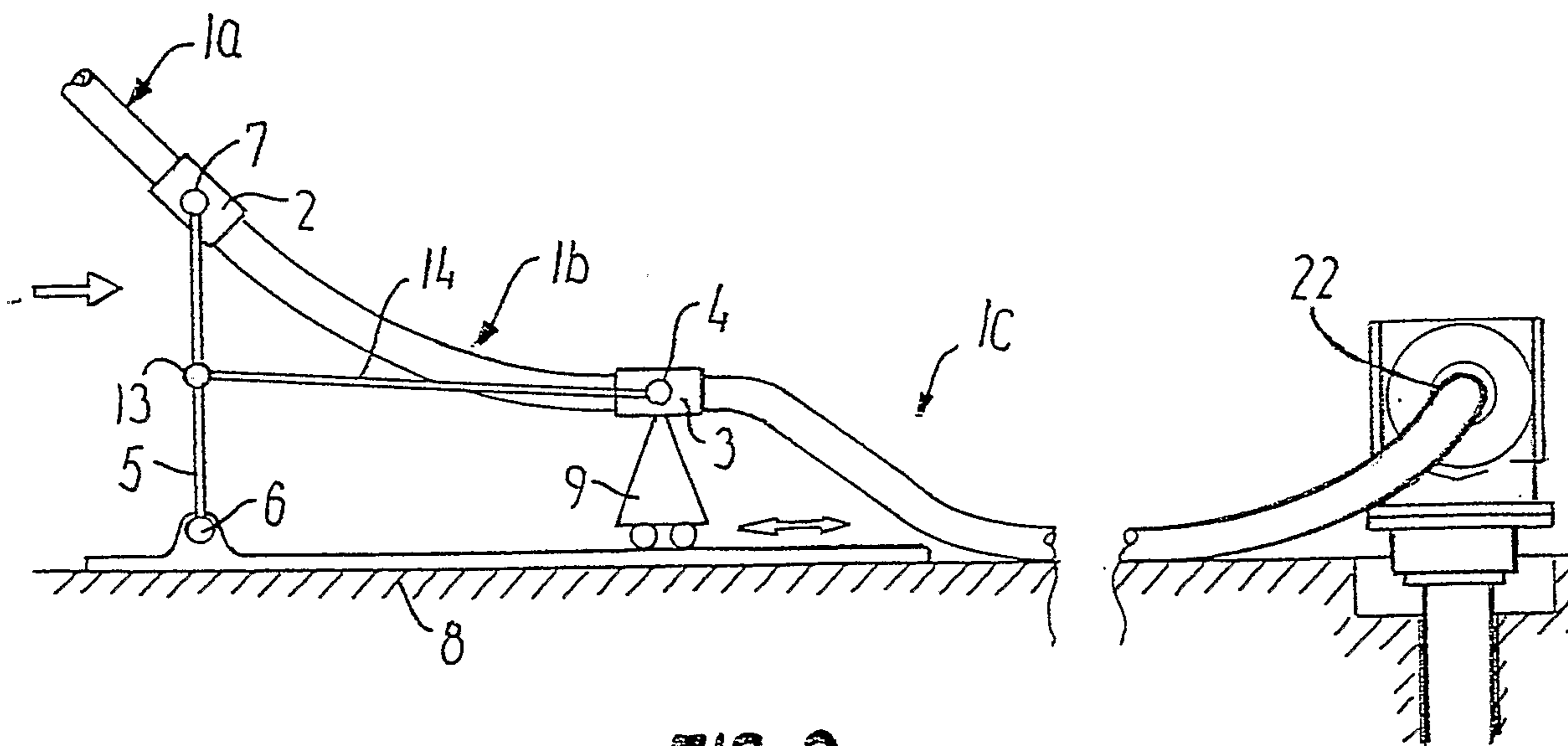

FIG. 2

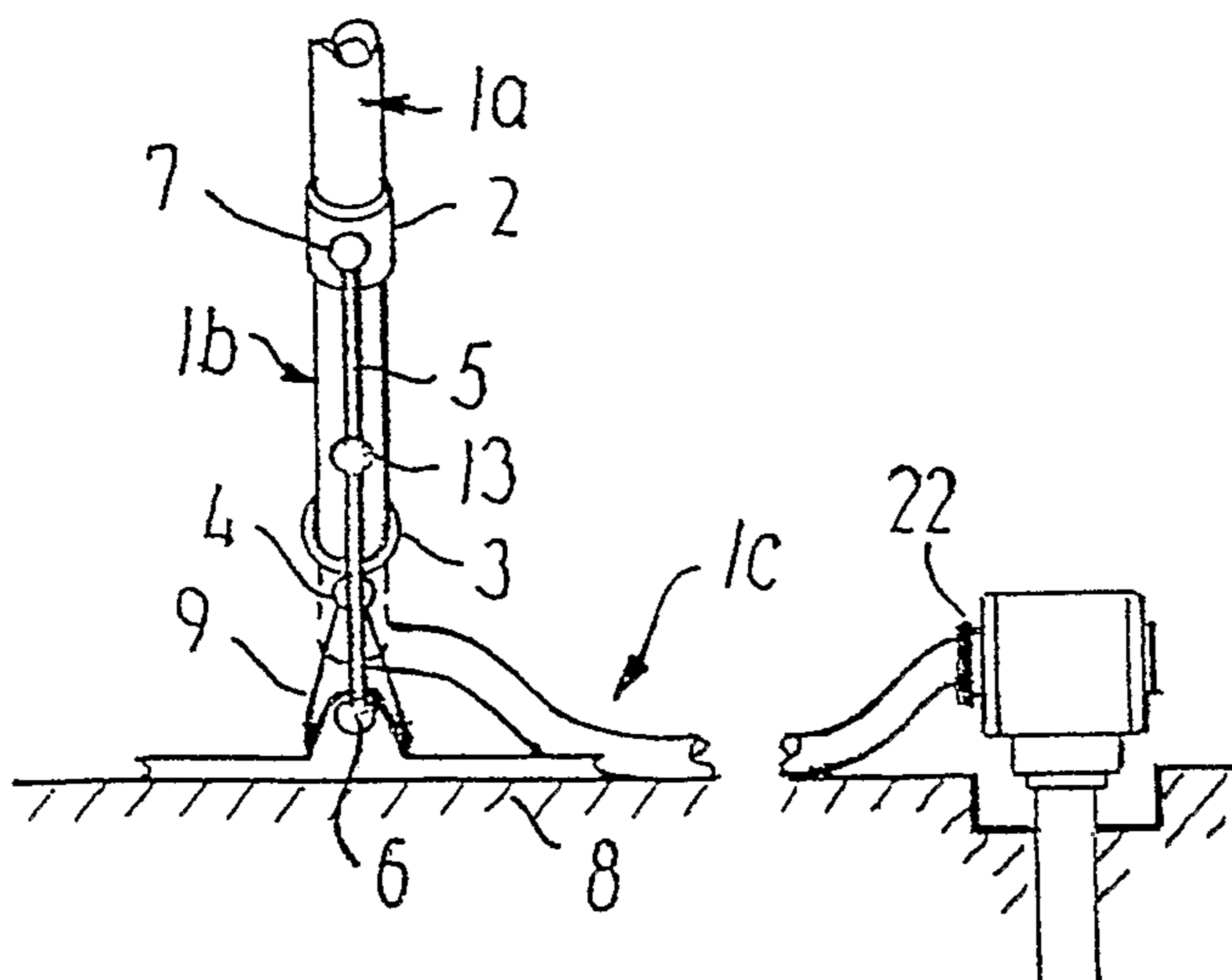

FIG. 2a

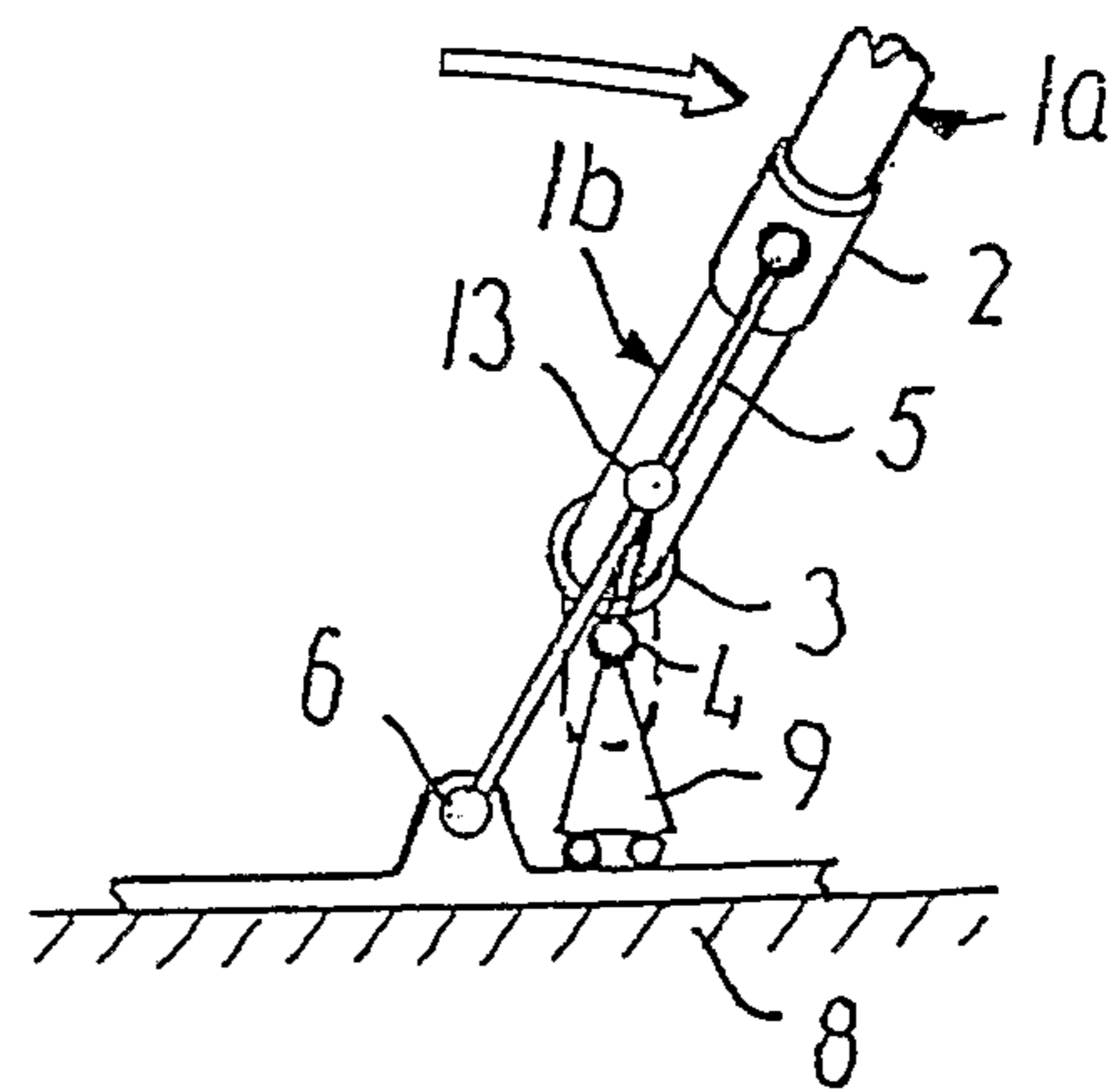

FIG. 2b

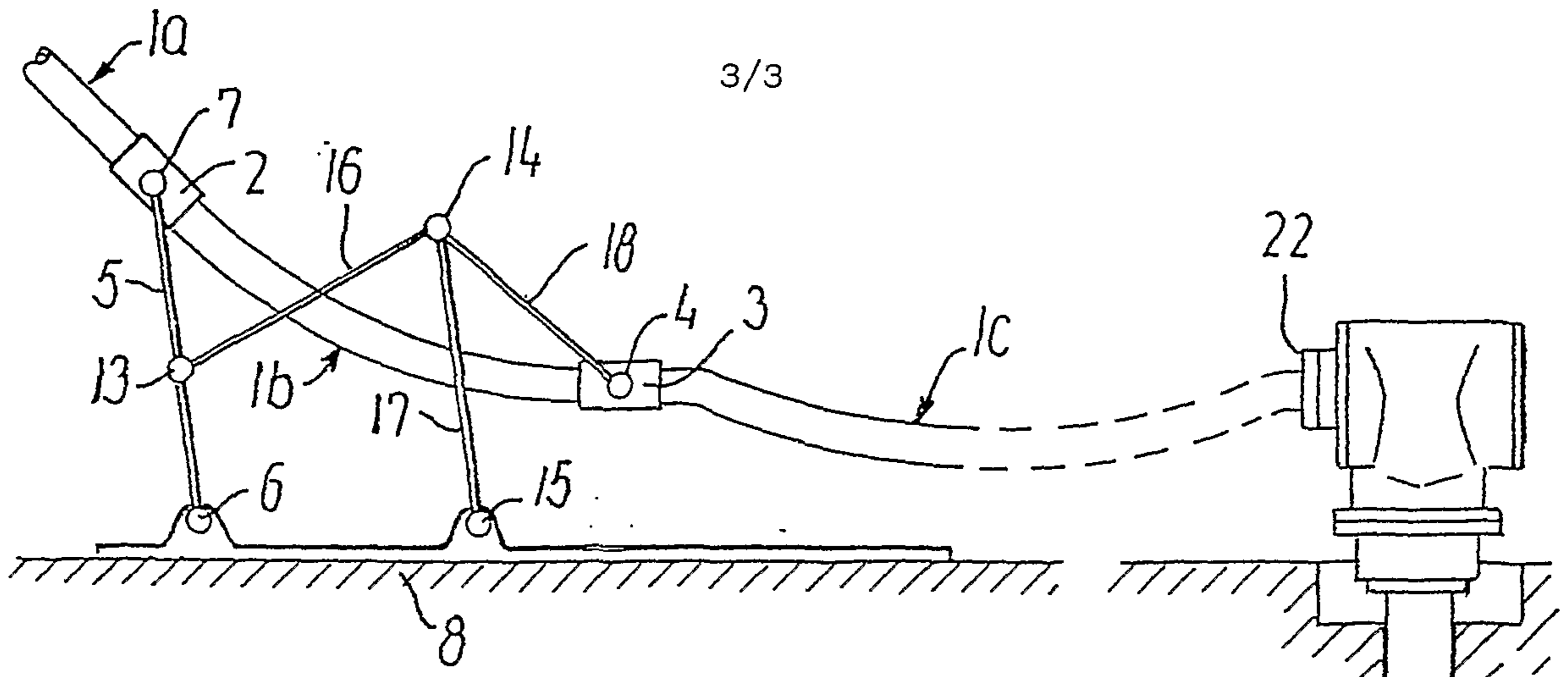

FIG. 3a

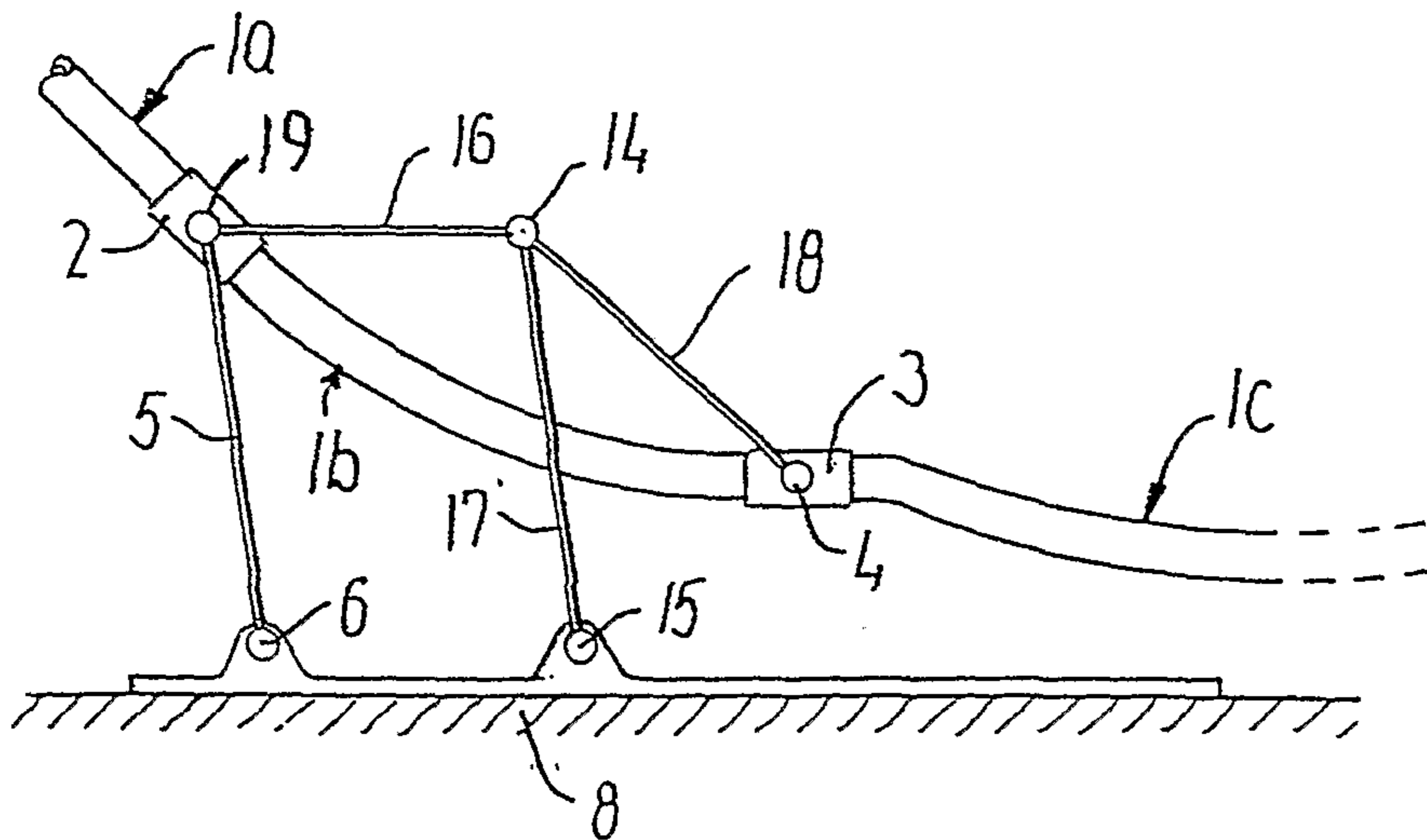

FIG. 3b

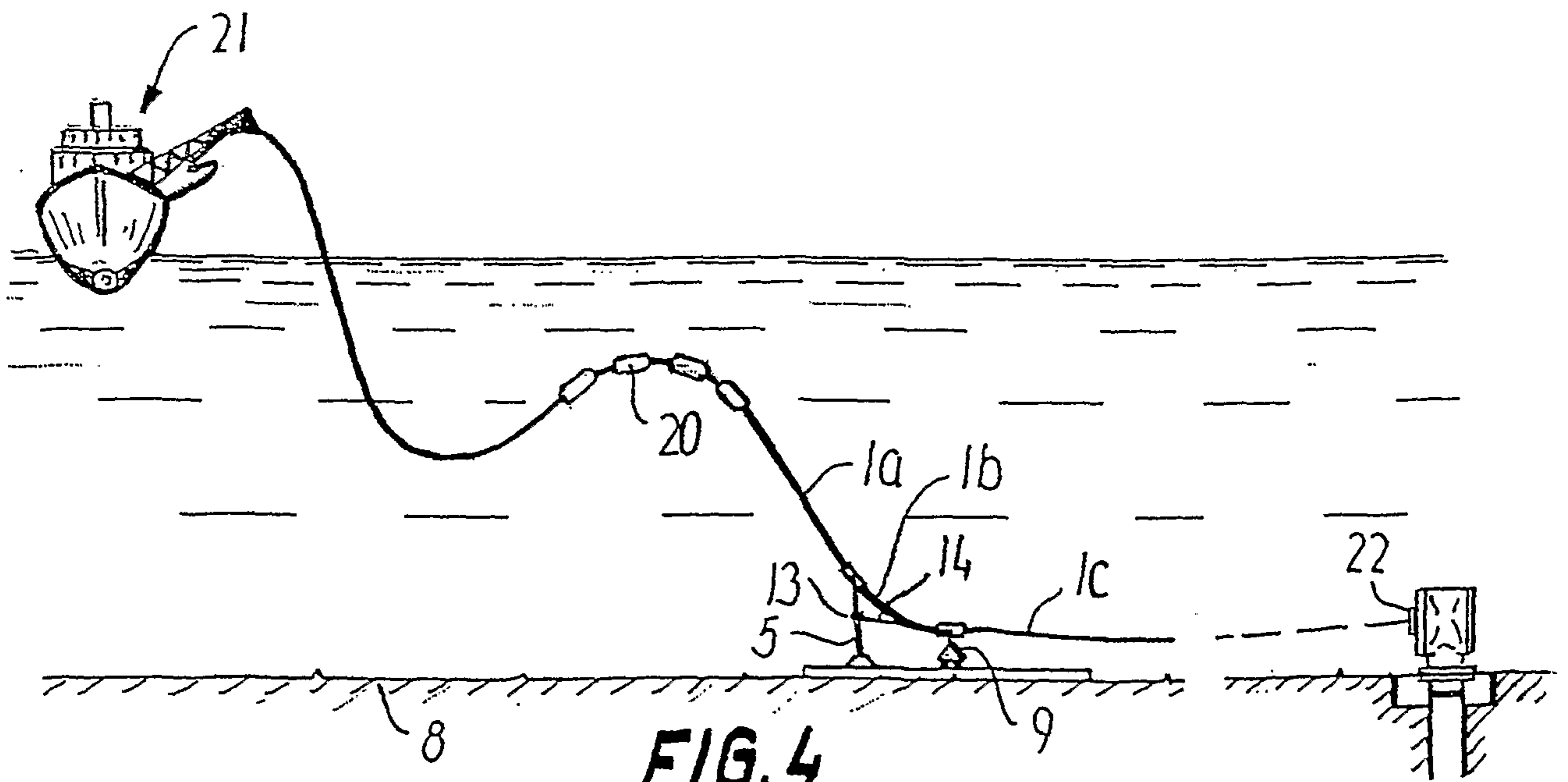

FIG. 4

