



- (51) **International Patent Classification:**
A63F 9/24 (2006.01) G07F 17/32 (2006.01)
- (21) **International Application Number:**
PCT/US2014/065811
- (22) **International Filing Date:**
14 November 2014 (14.11.2014)
- (25) **Filing Language:** English
- (26) **Publication Language:** English
- (30) **Priority Data:**
61/905,121 15 November 2013 (15.11.2013) US
61/925,211 8 January 2014 (08.01.2014) US
- (71) **Applicant:** GAMBLIT GAMING, LLC [US/US]; 700 North Central Avenue, 7th Floor, Glendale, CA 91203 (US).
- (72) **Inventors:** ARNONE, Miles; c/o Gamblit Gaming, LLC, 700 North Central Avenue, 7th Floor, Glendale, CA 91203 (US). MEYERHOFER, Eric; c/o Gamblit Gaming, LLC, 700 North Central Avenue, 7th Floor, Glendale, CA 91203 (US).
- (74) **Agent:** KIM, Dwight; c/o Gamblit Gaming, LLC, 700 North Central Avenue, 7th Floor, Glendale, CA 91203 (US).

(81) **Designated States** (unless otherwise indicated, for every kind of national protection available): AE, AG, AL, AM, AO, AT, AU, AZ, BA, BB, BG, BH, BN, BR, BW, BY, BZ, CA, CH, CL, CN, CO, CR, CU, CZ, DE, DK, DM, DO, DZ, EC, EE, EG, ES, FI, GB, GD, GE, GH, GM, GT, HN, HR, HU, ID, IL, IN, IR, IS, JP, KE, KG, KN, KP, KR, KZ, LA, LC, LK, LR, LS, LU, LY, MA, MD, ME, MG, MK, MN, MW, MX, MY, MZ, NA, NG, NI, NO, NZ, OM, PA, PE, PG, PH, PL, PT, QA, RO, RS, RU, RW, SA, SC, SD, SE, SG, SK, SL, SM, ST, SV, SY, TH, TJ, TM, TN, TR, TT, TZ, UA, UG, US, UZ, VC, VN, ZA, ZM, ZW.

(84) **Designated States** (unless otherwise indicated, for every kind of regional protection available): ARIPO (BW, GH, GM, KE, LR, LS, MW, MZ, NA, RW, SD, SL, ST, SZ, TZ, UG, ZM, ZW), Eurasian (AM, AZ, BY, KG, KZ, RU, TJ, TM), European (AL, AT, BE, BG, CH, CY, CZ, DE, DK, EE, ES, FI, FR, GB, GR, HR, HU, IE, IS, IT, LT, LU, LV, MC, MK, MT, NL, NO, PL, PT, RO, RS, SE, SI, SK, SM, TR), OAPI (BF, BJ, CF, CG, CI, CM, GA, GN, GQ, GW, KM, ML, MR, NE, SN, TD, TG).

Published:
— with international search report (Art. 21(3))

(54) **Title:** DISTRIBUTED COMPONENT INTERLEAVED WAGERING SYSTEM

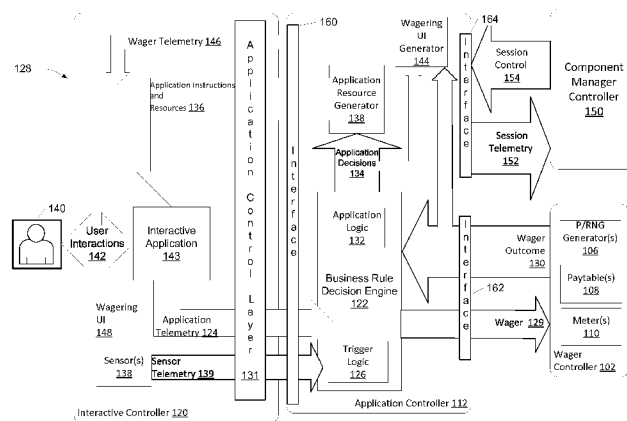
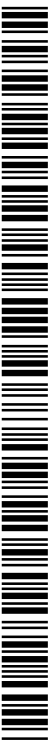

FIG. 1

(57) **Abstract:** A distributed component interleaved wagering system is disclosed. The system includes an interactive controller operatively connected to a component manager controller, the interactive controller constructed to: communicate an initialization indication; receive an identification of accessible components; communicate application telemetry and an identification of chosen components from the identification of accessible components; and receive application resources based on the communicated application telemetry. The system also includes the identified wager controller operatively connected to the component manager controller, the identified wager controller constructed to communicate a generated wager outcome, the generated wager outcome based on a wager request received from the component manager controller. The system also includes the identified application controller operatively connected to the component manager controller, the identified application controller constructed to: receive application telemetry; communicate the wager request; receive the wager outcome; communicate the application resources generated based on the wager outcome.



DISTRIBUTED COMPONENT INTERLEAVED WAGERING SYSTEM

CROSS REFERENCE TO RELATED APPLICATIONS

[0001] This application claims the benefit of U.S. Provisional Patent Application No. 61/905,121, filed November 15, 2013 and U.S. Provisional Patent Application No. 61/925,211, filed January 8, 2014, the disclosure of each of which is incorporated by reference herein in its entirety.

[0002] This application references Patent Cooperation Treaty Application No. PCT/US11/26768, filed March 1, 2011, Patent Cooperation Treaty Application No. PCT/US11/63587, filed December 6, 2011, and Patent Cooperation Treaty Application No. PCT/US12/58156, filed September 29, 2012, the contents of each of which are hereby incorporated by reference.

FIELD OF THE INVENTION

[0003] Embodiments of the present invention are generally related to communications within data processing systems. More particularly, the present invention relates to the communication and processing of wagering data.

BACKGROUND

[0004] The gaming industry has traditionally developed electronic gaming machines that present simple wagering games to a user. The communication and processing needs for these simple wagering games are easily met using conventional processing systems. However, more complicated wagering games need communication and processing systems that are better suited for implementing these more complicated wagering games. Various aspects of embodiments of the present invention meet such a need.

SUMMARY OF THE INVENTION

[0005] Systems and methods in accordance with embodiments of the invention provide a communication and data processing system constructed for a distributed component interleaved wagering system.

[0006] One embodiment includes a distributed component interleaved wagering system, comprising: an interactive controller operatively connected to a component manager controller, the interactive controller constructed to: communicate, to the component manager controller, an initialization indication; receive, from the component manager controller, an identification of accessible components, wherein the accessible components are components available for use with the interactive controller; communicate, to the component manager controller, application telemetry and an identification of chosen components from the identification of accessible components, wherein the identification of chosen components comprise an identification of a wager controller and an identification of an application controller; and receive, from the component manager controller, application resources based on the communicated application telemetry; the identified wager controller operatively connected to the component manager controller, the identified wager controller constructed to communicate, to the component manager controller, a generated wager outcome, the generated wager outcome based on a wager request received from the component manager controller; and the identified application controller operatively connected to the component manager controller, the identified application controller constructed to: receive, from the component manager controller, application telemetry received from the interactive controller; communicate, to the component manager controller, the wager request generated based on the received application telemetry; receive, from the component manager controller, the wager outcome generated by the wager controller based on the wager request; communicate, to the component manager controller, the application resources generated based on the wager outcome.

[0007] In a further embodiment, the component manager controller is constructed to: receive, from the interactive controller, the initialization indication; determine, based on the initialization indication, the accessible components; communicate, to the interactive controller, the identification of accessible components; receive, from the interactive controller, the application telemetry and identification of chosen components; and communicate, to the interactive controller, the application resources.

[0008] In a further embodiment, the component manager controller is further constructed to: communicate, to the identified application controller, based on the received identification of chosen components, the application telemetry; receive, from the identified application controller, the wager request; communicate, to the identified wager controller, based on the received identification of chosen components, the wager request; receive, from the identified wager controller, the wager outcome; communicate, to the identified application controller, the wager outcome; and receive, from the identified application controller, the application resources.

[0009] In a further embodiment, the component manager controller is constructed to: receive, from a component connected to the component manager controller, information associated with the component; and determine, based on the received information associated with the component, allowable combinations of components connected to the component manager controller.

[0010] In a further embodiment, the component manager controller is operatively connected to a jurisdictional authority, wherein the jurisdictional authority is constructed to communicate, to the component manager controller, accessibility rules; and the determination of allowable combinations of components connected to the component manager controller is based on the accessibility rules.

[0011] In a further embodiment, the component manager controller is connected to an accounting and audit database, wherein the accounting and audit database records fund transactions associated with the distributed component interleaved wagering system; and an accounting and audit report may be generated based on the accounting and audit database.

[0012] In a further embodiment, the interactive controller is further constructed to: provide a display, to a user, comprising the identified accessible components; and receive, from the user, the identification of chosen components.

[0013] Another embodiment includes a networked component manager controller of a distributed component interleaved wagering system, comprising: an interactive controller interface operatively connecting the component manager controller to an interactive controller of the distributed component interleaved wagering system; a wager controller interface operatively connecting the component manager controller

to a wager controller of the distributed component interleaved wagering system; an application controller interface operatively connecting the component manager controller to an application controller of the distributed component interleaved wagering system; and one or more processors constructed to: receive, from an interactive controller, an initialization indication; determine accessible components, wherein the accessible components are components available for use with the interactive controller; communicate, to the interactive controller, an identification of the accessible components; receive, from the interactive controller, application telemetry and an identification of chosen components from the identification of accessible components, wherein the identification of chosen components comprise an identification of the wager controller and an identification of the application controller; communicate, to the application controller, the application telemetry; receive, from the application controller, a wager request based on the application telemetry; communicate, to the wager controller, the wager request; receive, from the wager controller, a wager outcome based on the wager request; communicate, to the application controller, the wager outcome; receive, from the application controller, application resources based on the wager outcome; and communicate, to the interactive controller, the application resources

BRIEF DESCRIPTION OF THE DRAWINGS

[0014] FIG. 1 is a diagram of a structure of a distributed component interleaved wagering system in accordance with various embodiments of the invention.

[0015] FIGS. 2A, 2B, 2C, and 2D are illustrations of interactive controllers of a distributed component interleaved wagering system in accordance with various embodiments of the invention.

[0016] FIGS. 3A, 3B and 3C are network diagrams of distributed distributed component interleaved wagering systems in accordance with various embodiments of the invention.

[0017] FIGS. 4A and 4B are diagrams of a structure of an interactive controller of a distributed component interleaved wagering system in accordance with various embodiments of the invention.

[0018] FIGS. 5A and 5B are diagrams of a structure of a wager controller of a distributed component interleaved wagering system in accordance with various embodiments of the invention.

[0019] FIG. 6A and 6B are diagrams of a structure of an application controller of a distributed component interleaved wagering system in accordance with various embodiments of the invention.

[0020] FIGS. 7A and 7B are diagrams of a structure of a component manager controller of a distributed component interleaved wagering system in accordance with various embodiments of the invention.

[0021] FIG. 8 is a sequence diagram of interactions between components of a distributed component interleaved wagering system in accordance with various embodiments of the invention.

[0022] FIG. 9 is a collaboration diagram for components of a distributed component interleaved wagering system in accordance with various embodiments of the invention.

[0023] FIG. 10 illustrates components of the distributed component interleaved wagering system according to various embodiments of the invention.

[0024] FIGS. 11A-11C illustrate processes involving the distributed component interleaved wagering system according to various embodiments of the invention.

[0025] FIG. 12 illustrates the distributed component interleaved wagering system according to various embodiments of the invention.

[0026] FIGS. 13A and 13B illustrate a number of combinations of applications, operators, and service providers, from a user's perspective.

[0027] FIG. 14 is an illustration of a distributed component interleaved wagering system in accordance with embodiments of the invention.

[0028] FIG. 15 is a sequence diagram of interactions between components of a distributed component interleaved wagering system in accordance with various embodiments of the invention.

[0029] FIG. 16 is a sequence diagram of interactions between components of a distributed component interleaved wagering system in accordance with various embodiments of the invention.

DETAILED DESCRIPTION

[0030] A distributed component interleaved wagering system interleaves wagering with non-wagering activities. In some embodiments of a distributed component interleaved wagering system an interactive application executed by an interactive controller provides non-wagering components of the distributed component interleaved wagering system. The interactive controller is operatively connected to an application controller that manages and configures the interactive application of the interactive controller and determines when wagers should be interleaved with the operations of the interactive application. The application controller is further operatively connected to a wager controller that provides one or more wagering propositions for one or more wagers.

[0031] In some embodiments, the interactive controller also includes a wagering user interface that is used to display data about a wagering process, including but not limited a wager outcome of a wager made in accordance with a wagering proposition. The content of the wagering user interface is controlled by the application controller and includes content provided by the wager controller.

[0032] In several embodiments, a user or user interactions are represented in a distributed component interleaved wagering system by the electronic representation of interactions between the user and the interactive application, typically received via a user interface of the interactive application, and a user profile of the distributed component interleaved wagering system associated with the user.

[0033] Many different types of interactive applications may be utilized with the distributed component interleaved wagering system. In some embodiments, the interactive application reacts to the physical activity of the user. In these embodiments, the user interacts with the interactive application through one or more sensors that monitor the user's physical activities. Such sensors may include, but are not limited to, physiological sensors that monitor the physiology of the user, environmental sensors that monitor the physical environment of the user, accelerometers that monitor changes in motion of the user, and location sensors that monitor the location of the user such as global positioning sensors.

[0034] In some embodiments, the interactive application is a skill-based interactive game that is played by the user.

[0035] In some embodiments, the interactive application is a tool used by the user to achieve some useful goal.

[0036] In operation, a user interacts with the interactive application using various types of elements of the interactive application in an interactive application environment. Elements are interactive application resources utilized by the user within the interactive application environment to provide an interactive experience for the user. Wagers of credits are made in accordance with a wagering proposition as triggered by the user's use of one or more of the elements of the interactive application. Wager outcomes of wagers of credits made in accordance with the wagering proposition can cause consumption, loss or accrual of credits.

[0037] In accordance with some embodiments, wager outcomes of wagering events can influence elements in the interactive application such as, but not limited to, providing one or more new elements, restoring one or more consumed elements, causing the loss of one or more elements, and restoration or placement of one or more fixed elements.

[0038] In various embodiments, the wagers may be made using one or more credits (Cr).

[0039] In some embodiments, Cr can be one or more credits that are purchased using, and redeemed in, a real world currency having a real world value.

[0040] In many embodiments, Cr can be one or more credits in a virtual currency. Virtual currency is an alternate currency that can be acquired, purchased or transferred by or to a user, but does not necessarily directly correlate to a real world currency. In many such embodiments, Cr in a virtual currency are allowed to be purchased using a real world currency but are prevented from being redeemed in a real world currency having a real world value.

[0041] In several embodiments, during interaction with the interactive application using the elements, a user can optionally consume and/or accrue application environment credit (AC) within the interactive application as a result of the user's use of the interactive application. AC can be in the form of, but is not limited to, application environment credits, experience points, and points generally.

[0042] In various embodiments, when the interactive application is a skill-based interactive game, AC is awarded to a player of the skill-based interactive game on

the basis of the player's skillful play of the skill-based interactive game. In such embodiments, AC may be analogous to the score in a typical video game. The skill-based interactive game can have one or more scoring criteria, embedded within an application controller and/or an interactive controller that provides the skill-based interactive game, that reflect user performance against one or more goals of the skill-based interactive game.

[0043] In many embodiments, AC can be used to purchase in-application items, including but not limited to, application elements that have particular properties, power ups for existing items, and other item enhancements.

[0044] In some embodiments, AC may be used to earn entrance into a sweepstakes drawing, to earn entrance in a tournament with prizes, to score in the tournament, and/or to participate and/or score in any other game event.

[0045] In several embodiments, AC can be stored on a user-tracking card or in a network-based user tracking system where the AC is attributed to a specific user.

[0046] In many embodiments, a wagering proposition includes a wager of AC for a wager outcome of a randomly generated payout of interactive application AC, elements, and/or objects in accordance with a wagering proposition.

[0047] In a number of embodiments, a wager of an amount of Cr results in a wager outcome of a payout of AC, elements, and/or objects that have an Cr value if cashed out.

[0048] In some embodiments, in a case that an interactive application is a skill-based interactive game, interactive application objects include in-application objects that may be used by a player of the skill-based interactive game to enhance the player's gameplay of the skill-based interactive game. Such objects include, but are not limited to, power-ups, enhanced in-application items, and the like. In some embodiments, the interactive application objects include objects that are detrimental to the player's play of the skill-based interactive game such as, but not limited to, obstructions in the game space, a temporary player handicap, an enhanced opponent, and the like.

[0049] In some embodiments, elements in an interactive application include, but are not limited to, enabling elements (EE) that are interactive application environment resources utilized during the user's use of the interactive application

and whose utilization by the user while using the interactive application triggers execution of a wager in accordance with a wagering proposition. In another embodiment, elements in an interactive application include, but are not limited to, a reserve enabling element (REE), that is an element that converts into one or more enabling elements upon occurrence of a release event during an interactive user session. In yet another embodiment, elements in an interactive application include, but are not limited to, an actionable element (AE) that is an element that is acted upon during use of the interactive application to trigger a wager in accordance with a wagering proposition and may or may not be restorable during normal play of the interactive application. In yet another embodiment, elements in an interactive application include, but are not limited to, a common enabling element (CEE) that is an element that may be shared by two or more users and causes a wagering event and associated wager to be triggered in accordance with the wagering proposition when used by one of the users during use of the interactive application. In some embodiments, in progressing through interactive application use, a user can utilize elements during interactions with a controlled entity (CE). A CE is a character, entity, inanimate object, device or other object under control of a user.

[0050] In accordance with some embodiments of a distributed component interleaved wagering system, the triggering of the wagering event and/or wager can be dependent upon an interactive application environment variable such as, but not limited to, a required object (RO), a required environmental condition (REC), or a controlled entity characteristic (CEC). A RO is a specific interactive application object in an interactive application acted upon for an AE to be completed. A non-limiting example of an RO is a specific key needed to open a door. An REC is an interactive application state present within an interactive application for an AE to be completed. A non-limiting example of an REC is daylight whose presence enables a character to walk through woods. A CEC is a status of the CE within an interactive application for an AE to be completed. A non-limiting example of a CEC is requirement that a CE have full health points before entering battle. Although various interactive application resources such as, but not limited to, the types of interactive application elements as discussed herein may be used to trigger a wager in accordance with a wagering proposition, one skilled in the art will recognize that

any interactive application resource can be utilized in a distributed component interleaved wagering system to trigger of a wager as appropriate to the specification of a specific application in accordance with various embodiments of the invention.

[0051] In several embodiments, a distributed component interleaved wagering system can utilize an application controller to monitor use of the interactive application executed by an interactive controller for detecting a trigger of a wagering event. The trigger for the wagering event can be detected by the application controller from the utilization of the interactive application in accordance with at least one wagering event occurrence rule. The trigger of the wagering event can be communicated to a wager controller. In response to notification of the trigger, the wager controller executes a wager in accordance with a wagering proposition. In addition, use of an interactive application in a distributed component interleaved wagering system can be modified by the application controller based upon the wager outcome.

[0052] In several embodiments, a wagering event occurrence can be determined from one or more application environment variables within an interactive application that are used to trigger a wager and/or associated wager in accordance with a wagering proposition. Application environment variables can include, but are not limited to, passage of a period of time during distributed component interleaved wagering system interactive application use, a result from a distributed component interleaved wagering system interactive application user session (such as, but not limited to, achieving a goal or a particular score), a user action that is a consumption of an element, or a user action that achieves a combination of elements to be associated with a user profile.

[0053] In numerous embodiments, an interactive application instruction is an instruction to an interactive controller and/or an interactive application to modify an interactive application application state or modify one or more interactive application resources. In some embodiments, the interactive application instructions may be based upon one or more of a wager outcome and application environment variables. An interactive application instruction can modify any aspect of an interactive application, such as, but not limited to, an addition of a period of time available for a current interactive application user session for the interactive application of

distributed component interleaved wagering system, an addition of a period of time available for a future distributed component interleaved wagering system interactive application user session or any other modification to the interactive application elements that can be utilized during interactive application use. In some embodiments, an interactive application instruction can modify a type of element whose consumption triggers a wagering event occurrence. In many embodiments, an interactive application instruction can modify a type of element whose consumption is not required in a wagering event occurrence.

[0054] In a number of embodiments, a user interface can be utilized that depicts a status of the interactive application in the distributed component interleaved wagering system. A user interface can depict any aspect of an interactive application including, but not limited to, an illustration of distributed component interleaved wagering system interactive application use advancement as a user uses the distributed component interleaved wagering system.

[0055] In some embodiments, a distributed component interleaved wagering system including an application controller operatively connected to a wager controller and operatively connected to an interactive controller may provide for interleaving entertainment content from an interactive application. The distributed component interleaved wagering system provides for random wager outcomes in accordance with the wagering proposition that are independent of user skill while providing an interactive experience to the user that may be shaped by the user's skill.

[0056] In several embodiments, an application controller of a distributed component interleaved wagering system may provide for a communications interface for asynchronous communications between a wager controller and an interactive application provided by an interactive controller, by operatively connecting the interactive controller, and thus the interactive controller's interactive application, with the wager controller. In some embodiments, asynchronous communications provided for by a distributed component interleaved wagering system may reduce an amount of idle waiting time by an interactive controller of the distributed component interleaved wagering system, thus increasing an amount of processing resources that the interactive controller may provide to an interactive application or other processes of the interactive controller. In many embodiments, asynchronous

communications provided for by a distributed component interleaved wagering system reduces an amount of idle waiting time by a wager controller, thus increasing an amount of processing resources that the wager controller may provide to execution of wagers to determine wager outcomes, and other processes provided by the wager controller. In some embodiments, a wager controller of a distributed component interleaved wagering system may be operatively connected to a plurality of interactive controllers through one or more application controllers and the asynchronous communications provided for by the one or more application controllers allows the wager controller to operate more efficiently and provide wager outcomes to a larger number of interactive controllers than would be achievable without the one or more application controllers of the distributed component interleaved wagering system.

[0057] In some embodiments, a distributed component interleaved wagering system including an application controller operatively connected to a wager controller and operatively connected to an interactive controller may provide for simplified communication protocols for communications of the interactive controller as the interactive controller may communicate user interactions with an interactive application provided by the interactive controller to the application controller without regard to a nature of a wagering proposition to be interleaved with processes of the interactive application.

[0058] In various embodiments, a distributed component interleaved wagering system including an application controller operatively connected to a wager controller and operatively connected to an interactive controller may provide for simplified communication protocols for communications of the wager controller as the wager controller may receive wager requests and communicate wager outcomes without regard to a nature of an interactive application provided by the interactive controller.

[0059] Various types interleaved wagering systems are discussed in Patent Cooperation Treaty Application No. PCT/US11/26768, filed March 1, 2011, Patent Cooperation Treaty Application No. PCT/US11/63587, filed December 6, 2011, and Patent Cooperation Treaty Application No. PCT/US12/58156, filed September 29, 2012, the contents of each of which are hereby incorporated by reference in their entirety.

distributed component Wagering Interleaved Systems

[0060] FIG. 1 is a diagram of a structure of a distributed component interleaved wagering system in accordance with various embodiments of the invention. The distributed component interleaved wagering system 128 includes an interactive controller 120, an application controller 112, and a wager controller 102. The interactive controller 120 is operatively connected to, and communicates with, the application controller 112. The application controller 112 is also operatively connected to, and communicates with, the wager controller 102.

[0061] In several embodiments, the wager controller 102 is a controller for providing one or more wagering propositions provided by the distributed component interleaved wagering system 128 and executes wagers in accordance with the wagering propositions. Types of value of a wager can be one or more of several different types. Types of value of a wager can include, but are not limited to, a wager of an amount of Cr corresponding to a real currency or a virtual currency, a wager of an amount of AC earned by the player through use of an interactive application, a wager of an amount of elements of an interactive application, and a wager of an amount of objects used in an interactive application. A wager outcome determined for a wager in accordance with a wagering proposition can increase or decrease an amount of the type of value used in the wager, such as, but not limited to, increasing an amount of Cr for a wager of Cr. In various embodiments, a wager outcome determined for a wager in accordance with a wagering proposition can increase or decrease an amount of a type of value that is different than a type of value of the wager, such as, but not limited to, increasing an amount of an object of an interactive application for a wager of Cr.

[0062] In many embodiments, the wager controller 120 includes one or more pseudo random or random number generators (P/RNG) 106 for generating random results, one or more paytables 108 for determining a wager outcome from the random results, and one or more credit or value meters 110 for storing amounts of wagered and won credits.

[0063] The one or more P/RNG generators 106 execute processes that can generate random or pseudo random results. The one or more paytables 108 are

tables that can be used in conjunction with the random or pseudo random results to determine a wager outcome including an amount of Cr, AC, elements or objects won as a function of distributed component interleaved wagering system use. There can be one or more paytables 108 in the wager controller 102. The paytables 108 are used to implement one or more wagering propositions in conjunction with a random output of the random or pseudo random results.

[0064] In some embodiments, selection of a paytable to use to execute a wager can be based on factors including, but not limited to, interactive application progress a user has achieved through use of the interactive application, user identification, and eligibility of the user for bonus rounds.

[0065] In various embodiments, the interactive controller 120 provides an interactive application 143 and provides human input devices (HIDs) and output devices for interacting with the user 140. The interactive controller 120 provides for user interactions 142 with the interactive application 143 by receiving input from a user through the HIDs and providing outputs such as video, audio and/or other sensory output to the user using the output devices.

[0066] The interactive controller 120 is operatively connected to, and communicates with, the application controller 112. The interactive controller communicates application telemetry data 124 to the application controller 112 and receives application instructions and resources 136 from the application controller 112. Via the communication of application instructions and resources 136, the application controller 112 can communicate certain interactive application resources including control parameters to the interactive application 143 to affect the interactive application's execution by the interactive controller 120. In various embodiments, these interactive application control parameters can be based on a wager outcome of a wager that was triggered by an element in the interactive application being utilized or acted upon by the user.

[0067] In some embodiments, execution of the interactive application by the interactive controller 120 communicates user interactions with the interactive application to the application controller 112. The application telemetry data 124

includes, but is not limited to, the user's utilization of the elements in the interactive application.

[0068] In some embodiments, the interactive application 143 is a skill-based interactive game. In such embodiments, execution of the skill-based interactive game by the interactive controller 120 is based on the user's skillful play of the skill-based interactive game. The interactive controller 120 can also communicate user choices made in the skill-based interactive game to the application controller 112 included in the application telemetry data 124 such as, but not limited to, the user's utilization of the elements of the skill-based interactive game during the user's skillful play of the skill-based interactive game. In such an embodiment, the application controller is interfaced to the interactive controller 120 in order to allow the coupling of the skill-based interactive game to wagers made in accordance with a wagering proposition.

[0069] In some embodiments, the interactive controller 120 includes one or more sensors 138 that sense various aspects of the physical environment of the interactive controller 120. Examples of sensors include, but are not limited to: global positioning sensors (GPSs) for sensing communications from a GPS system to determine a position or location of the interactive controller; temperature sensors; accelerometers; pressure sensors; and the like. Sensor telemetry data 128 is communicated by the interactive controller to the application controller 112. The application controller 112 receives the sensor telemetry data 128 and uses the sensory telemetry data to make wager decisions.

[0070] In many embodiments, the interactive controller includes a wagering user interface 148 used to display wagering data to the user.

[0071] In various embodiments, an application control layer 131 resident in the interactive controller 120 provides an interface between the interactive controller 120 and the application controller 112.

[0072] In many embodiments, application controller 112 provides an interface between the interactive application 143 provided by the interactive controller 120 and a wagering proposition provided by the wager controller 102.

[0073] In some embodiments, the application controller 112 includes an interactive controller interface 160 to an interactive controller. The interactive controller interface 160 provides for the communication of data between the interactive controller and the application controller, including but not limited to wager telemetry data 146, application instructions and resources 136, application telemetry data 124, and sensor telemetry data 128.

[0074] In various embodiments, the application controller 112 includes a wager controller interface 162 to a wager controller. The wager controller interface 162 provides for communication of data between the application controller 112 and the wager controller, including but not limited to wager outcome data 130 and wager data 129.

[0075] In some embodiments, the application controller 112 includes a component manager controller interface 164 to a component manager controller. The component manager controller interface 164 provides for communication of data between the application controller 112 and the component manager controller, including but not limited to user session control data 154 and user session telemetry data 152.

[0076] The application controller 112 includes a business rule decision engine 122 that receives telemetry data, such as application telemetry data 124 and sensor telemetry data 128, from the interactive controller 120. The business rule decision engine 122 uses the telemetry data, along with trigger logic 126 to generate wager data 129 used to trigger a wager in the wager controller 102.

[0077] In some embodiments, the application telemetry data 124 includes, but is not limited to, application environment variables that indicate the state of the interactive application 143 being used by a user 140, interactive controller data indicating the state of the interactive controller, and user actions and interactions 142 between the user and the interactive application 143 provided by the interactive controller 120. The wagering and/or wager data 129 may include, but is not limited to, an amount and type of the wager, a trigger of the wager, and a selection of a payable 108 to be used when executing the wager.

[0078] In some embodiments, the business rule decision engine 122 also receives wager outcome data 130 from the wager controller 102. The decision

engine 122 uses the wager outcome data 130, in conjunction with the telemetry data and application logic 132 to generate application decisions 134 communicated to an application resource generator 138. The application resource generator 138 receives the application decisions and uses the application decisions to generate application instructions and application resources 136 to be communicated to the interactive application 143.

[0079] In many embodiments, the application controller 112 includes a pseudo random or random result generator used to generate random results that are communicated to the application resource generator 138. The application resource generator 138 uses the random results to generate application instructions and application resources 136 to be communicated to the interactive application 143.

[0080] In various embodiments, the business rule decision engine 122 also determines an amount of AC to award to the user 140 based at least in part on the user's use of the interactive application of the distributed component interleaved wagering system as determined from the application telemetry data 124. In some embodiments, wager outcome data 130 may also be used to determine the amount of AC that should be awarded to the user.

[0081] In numerous embodiments, the interactive application is a skill-based interactive game and the AC is awarded to the user for the user's skillful play of the skill-based interactive game.

[0082] In some embodiments, the application decisions 134 and wager outcome data 130 are communicated to a wagering user interface generator 144. The wagering user interface generator 144 receives the application decisions 134 and wager outcome data 130 and generates wager telemetry data 146 describing the state of wagering and credit accumulation and loss for the distributed component interleaved wagering system. In some embodiments, the wager telemetry data 146 may include, but is not limited to, amounts of AC and elements earned, lost or accumulated by the user through use of the interactive application as determined from the application decisions, and Cr amounts won, lost or accumulated as determined from the wager outcome data 130 and the one or more meters 110.

[0083] In some embodiments, the wager outcome data 130 also includes data about one or more game states of a gambling game executed in accordance with a

wagering proposition by the wager controller 102. In various such embodiments, the wagering user interface generator 144 generates a gambling game process display and/or gambling game state display using the one or more game states of the gambling game. The gambling game process display and/or gambling game state display is included in the wager telemetry data 146 that is communicated to the interactive controller 120. The gambling game process display and/or a gambling game state display is displayed by the wagering user interface 148 to the user 140. In other such embodiments, the one or more game states of the gambling game are communicated to the interactive controller 120 and the wagering user interface 148 generates the gambling game process display and/or gambling game state display using the one or more game states of the gambling game for display to the user 140.

[0084] The application controller 112 can further operatively connect to the wager controller 102 to determine an amount of credit or elements available and other wagering metrics of a wagering proposition. Thus, the application controller 112 may potentially affect an amount of Cr in play for participation in the wagering events of a wagering game provided by the wager controller 102 in some embodiments. The application controller 112 may additionally include various audit logs and activity meters. In some embodiments, the application controller 112 can also couple to a centralized server for exchanging various data related to the user and the activities of the user during game play of a distributed component interleaved wagering system.

[0085] In many embodiments, one or more users can be engaged in using the interactive application executed by the interactive controller 120. In various embodiments, a distributed component interleaved wagering system can include an interactive application that provides a skill-based interactive game that includes head-to-head play between a single user and a computing device, between two or more users against one another, or multiple users playing against a computer device and/or each other. In some embodiments, the interactive application can be a skill-based interactive game where the user is not skillfully playing against the computer or any other user such as skill-based interactive games where the user is effectively skillfully playing against himself or herself.

[0086] In some embodiments, the operation of the application controller 112 does not affect the provision of a wagering proposition by the wager controller 102 except for user choice parameters that are allowable in accordance with the wagering proposition. Examples of user choice parameters include, but are not limited to: wager terms such as but not limited to a wager amount; speed of game play (for example, by pressing a button or pulling a handle of a slot machine); and/or agreement to wager into a bonus round.

[0087] In various embodiments, wager outcome data 130 communicated from the wager controller 102 can also be used to convey a status operation of the wager controller 102.

[0088] In a number of embodiments, communication of the wager data 129 between the wager controller 102 and the application controller 112 can further be used to communicate various wagering control factors that the wager controller 102 uses as input. Examples of wagering control factors include, but are not limited to, an amount of Cr, AC, elements, or objects consumed per wagering event, and/or the user's election to enter a jackpot round.

[0089] In some embodiments, the application controller 112 utilizes the wagering user interface 148 to communicate certain interactive application data to the user, including but not limited to, club points, user status, control of the selection of choices, and messages which a user can find useful in order to adjust the interactive application experience or understand the wagering status of the user in accordance with the wagering proposition in the wager controller 102.

[0090] In some embodiments, the application controller 112 utilizes the wagering user interface 148 to communicate aspects of a wagering proposition to the user including, but not limited to, odds of certain wager outcomes, amount of Cr, AC, elements, or objects in play, and amounts of Cr, AC, elements, or objects available.

[0091] In a number of embodiments, the wager controller 102 can accept wager proposition factors including, but not limited to, modifications in the amount of Cr, AC, elements, or objects wagered on each individual wagering event, a number of wagering events per minute the wager controller 102 can resolve, entrance into a bonus round, and other factors. An example of a varying wager amount that the

user can choose can include, but is not limited to, using a more difficult interactive application level associated with an amount of a wager. These factors can increase or decrease an amount wagered per individual wagering proposition in the same manner that a standard slot machine player can decide to wager more or less credits for each pull of the handle. In several embodiments, the wager controller 102 can communicate a number of factors back and forth to the application controller 112, via an interface, such that an increase/decrease in a wagered amount can be related to the change in user profile of the user in the interactive application. In this manner, a user can control a wager amount per wagering event in accordance with the wagering proposition with the change mapping to a parameter or component that is applicable to the interactive application experience.

[0092] In some embodiments, a component manager controller 150 is used to authorize a distributed component interleaved wagering system user session. The component manager controller receives game user session data 152, that may include, but is not limited to, user, interactive controller, application controller and wager controller data from the application controller 112. The component manager controller 150 uses the user, interactive controller, application controller and wager controller data to regulate a distributed component interleaved wagering system user session. In some embodiments, the component manager controller may also assert control of a distributed component interleaved wagering system game user session 154. Such control may include, but is not limited to, ending a distributed component interleaved wagering system game user session, initiating wagering in a distributed component interleaved wagering system game user session, ending wagering in a distributed component interleaved wagering system game user session but not ending a user's play of the interactive application portion of the distributed component interleaved wagering system game, and changing from real credit wagering in a distributed component interleaved wagering system to virtual credit wagering, or vice versa. In some embodiments, the component manager controller 150 communicates directly with the interactive controller 120.

Distributed Component Interleaved Wagering System Controllers

[0093] FIGS. 2A, 2B, 2C, and 2D are illustrations of interactive controllers of a distributed component interleaved wagering system in accordance with various embodiments of the invention. An interactive controller, such as interactive controller 120 of FIG. 1, may be constructed from or configured using one or more processing devices configured to perform the operations of the interactive controller. An interactive controller may be constructed from or configured using an electronic gaming machine 200 as shown in FIG. 2A. The electronic gaming machine 200 may be physically located in various types of gaming establishments. An interactive controller may be constructed from or configured using a portable device 202 as shown in FIG. 2B. The portable device 202 is a device that may wirelessly connect to a network. Examples of portable devices include, but are not limited to, a tablet computer, a personal digital assistant, and a smartphone. An interactive controller may be constructed from or configured using a gaming console 204 as shown in FIG. 2C. An interactive controller may be constructed from or configured using a personal computer 206 as shown in FIG. 2D. Indeed, an interactive controller in a distributed component interleaved wagering system may be constructed from or configured using any processing device including sufficient processing and communication capabilities that may be configured to perform the processes of an interactive controller in accordance with various embodiments of the invention.

[0094] Some distributed component interleaved wagering systems in accordance with many embodiments of the invention can operate with their components being network connected or can communicate with other distributed component interleaved wagering systems. In many embodiments, operations associated with components of a distributed component interleaved wagering system can be performed on a single device or across multiple devices. These multiple devices can be constructed from or configured using a single server or a plurality of servers such that a distributed component interleaved wagering system is executed as a system in a virtualized space such as, but not limited to, where a wager controller and an application controller are large scale centralized servers in the cloud operatively connected to widely distributed interactive controllers via a wide area network such as the Internet or a local area network. In such embodiments, the components of a

distributed component interleaved wagering system may communicate using a networking protocol or other type of device-to-device communications protocol.

[0095] In many embodiments, a centralized wager controller is operatively connected to, and communicates with, one or more application controllers via a network. The centralized wager controller can generate wager outcomes for wagers in accordance with one or more wagering propositions. The centralized wager controller can execute a number of simultaneous or pseudo-simultaneous wagers in order to generate wager outcomes for a variety of wagering propositions that one or more networked distributed component interleaved wagering systems can use.

[0096] In several embodiments, a centralized application controller is operatively connected to one or more interactive controllers and one or more wager controllers via a network. The centralized application controller can perform the functionality of an application controller across various distributed component interleaved wagering systems.

[0097] In a variety of embodiments, management of user profile data can be performed by a component manager controller operatively connected to, and communicating with, one or more application controllers, wager controllers and interactive controllers via a network. A component manager controller can manage data related to a user profile. The managed data in the user profile may include, but is not limited to, data concerning controlled entities (characters) in interactive application use, user performance metrics for a type or class of interactive application, interactive application elements acquired by a user; Cr and AC associated with a particular user, and tournament reservations.

[0098] Although a component manager controller is discussed as being separate from an application controller server, a centralized application controller server may also perform the functions of a component manager controller in some embodiments.

[0099] In a number of embodiments, an application controller of a distributed component interleaved wagering system can communicate data to a component manager controller. The data communicated by the application controller to the component manager controller may include, but is not limited to, AC and Cr used in

an interactive application; user profile data; user interaction activity; profile data for users; synchronization data between a wager controller and an interactive application; and data about other aspects of a distributed component interleaved wagering system. In several embodiments, a component manager controller can communicate user data to an application controller of a distributed component interleaved wagering system. The user data may include, but is not limited to, interactive application title and type; tournament data; special offers; character or profile setup and synchronization data between a wagering game and an interactive application; and data about any other aspect of a distributed component interleaved wagering system.

[00100] In numerous embodiments, an interactive application server provides a host for managing head-to-head play operating over a network of interactive controllers connected to the interactive application server via a network. The interactive application server provides an environment where users can compete directly with one another and interact with other users.

[00101] Processing devices connected via a network to construct distributed component interleaved wagering systems in accordance with many embodiments of the invention can communicate with each other to provide services utilized by a distributed component interleaved wagering system. In several embodiments, a wager controller can communicate with an application controller over a network. In some embodiments, the wager controller can communicate with an application controller to communicate any type of data as appropriate for a specific application. Examples of the data that may be communicated include, but are not limited to, data used to configure the various simultaneous or pseudo simultaneous wager controllers executing in parallel within the wager controller to accomplish distributed component interleaved wagering system functionalities; data used to determine metrics of wager controller performance such as wagers run and/or wager outcomes for tracking system performance; data used to perform audits and/or provide operator reports; and data used to request the results of a wager outcome for use in one or more function(s) operating within the application controller such as, but not limited to, automatic drawings for prizes that are a function of interactive controller performance.

[00102] In several embodiments, an application controller can communicate with an interactive application server via a network when the interactive application server is also communicating with one or more interactive controllers over a network. An application controller can communicate with an interactive application server to communicate any type of data as appropriate for a specific application. The data that may be communicated between an application controller and an interactive application server includes, but is not limited to, the data for management of an interactive application server by an application controller server during a distributed component interleaved wagering system tournament. In an example embodiment, an application controller may not be aware of the relationship of the application controller to the rest of a tournament since the actual tournament play may be managed by the interactive application server. Therefore, management of a distributed component interleaved wagering system can include, but is not limited to tasks including, but not limited to, conducting tournaments according to system programming that can be coordinated by an operator of the distributed component interleaved wagering system; allowing entry of a particular user into a tournament; communicating the number of users in a tournament; and the status of the tournament (such as, but not limited to the amount of surviving users, the status of each surviving user within the game, and time remaining on the tournament); communicating the performance of users within the tournament; communicating the scores of the various users in the tournament; and providing a synchronizing link to connect the application controllers in a tournament with their respective interactive controllers.

[00103] In several embodiments, an application controller can communicate with a component manager controller via a network. An application controller can communicate with a component manager controller to communicate any type of data as appropriate for a specific application. Examples of data communicated between an application controller and a component manager controller include, but are not limited to, data for configuring tournaments according to system programming conducted by an operator of a distributed component interleaved wagering system; data for exchange of data used to link a user's user profile to an ability to participate in various forms of distributed component interleaved wagering system use (such as

but not limited to the difficulty of play set by the application controller server for an interactive application that is a skill-based interactive game); data for determining a user's ability to participate in a tournament as a function of a user's characteristics (such as but not limited to a user's prowess or other metrics used for tournament screening); data for configuring application controller and interactive controller performance to suit preferences of a user on a particular distributed component interleaved wagering system; and data for determining a user's use and wagering performance for the purposes of marketing intelligence; and data for logging secondary drawing awards, tournament prizes, Cr and/or AC into the user profile.

[00104] In many embodiments, the actual location of where various process are executed can be located either on a single device (wager controller, application controller, interactive controller), on servers (wager controller, application controller, or interactive application server), or a combination of both devices and servers. In a number of embodiments, certain functions of a wager controller, application controller, component manager controller and/or interactive application server can operate on a local wager controller, application controller and/or interactive controller used to construct a distributed component interleaved wagering system being provided locally on a device. In some embodiments, a controller or server can be part of a server system including multiple servers, where applications can be run on one or more physical devices. Similarly, in particular embodiments, multiple servers can be combined on a single physical device.

[00105] Some distributed component interleaved wagering systems in accordance with many embodiments of the invention can be distributed across a network in various configurations. FIGS. 3A, 3B and 3C are network diagrams of networked distributed component interleaved wagering systems in accordance with various embodiments of the invention. Turning now to FIG. 3A, one or more interactive controllers of a networked distributed component interleaved wagering system, such as but not limited to, a mobile or wireless device 300, a gaming console 302, a personal computer 304, and an electronic gaming machine 305, are operatively connected with a wager controller 306 and a component manager controller 307 of a networked distributed component interleaved wagering system over a network 308. Network 308 is communications network that allows processing systems

communicate with each other and to share data. Examples of the network 308 can include, but are not limited to, a Local Area Network (LAN) and a Wide Area Network (WAN). In some embodiments, one or more processes of an interactive controller and an application controller as described herein are executed on the individual interactive controllers 300, 302, 304 and 305 while one or more processes of a wager controller as described herein can be executed by the wager controller 306 and one or more processes of a component manager controller as described herein can be executed by the component manager controller 307.

[00106] A networked distributed component interleaved wagering system in accordance with another embodiment of the invention is illustrated in FIG. 3B. As illustrated, one or more interactive controllers of a networked distributed component interleaved wagering system, such as but not limited to, a mobile or wireless device 310, a gaming console 312, a personal computer 314, and an electronic gaming machine 315, are operatively connected with a wager controller server 316, an application controller 318, and a component manager controller 319 over a network 320. Network 320 is a communications network that allows processing systems to communicate and share data. Examples of the network 320 can include, but are not limited to, a Local Area Network (LAN) and a Wide Area Network (WAN). In some embodiments, the processes of an interactive controller as described herein are executed on the individual interactive controllers 310, 312, 314 and 315. One or more processes of a wager controller as described herein are executed by the wager controller 316, one or more processes of an application controller as described herein are executed by the application controller 318, and one or more processes of a component manager controller as described herein are executed by the component manager controller 319.

[00107] A networked distributed component interleaved wagering systems in accordance with still another embodiment of the invention is illustrated in FIG. 3C. As illustrated, one or more interactive controllers of a networked distributed component interleaved wagering system, such as but not limited to, a mobile device 342, a gaming console 344, a personal computer 346, and an electronic gaming machine 340 are operatively connected with a wager controller 348, an application controller 350, an interactive application server 352, and a component manager

controller 353 over a network 354. Network 354 is a communications network that allows processing systems communicate and to share data. Examples of the network 354 can include, but are not limited to, a Local Area Network (LAN) and a Wide Area Network (WAN). In some embodiments, one or more processes of a display and user interface of an interactive controller as described herein are executed on the individual interactive controllers 340, 342, 344 and 346. One or more processes of a wager controller as described herein can be executed by the wager controller server 348. One or more processes of an application controller as described herein can be executed by the application controller server 350 and one or more processes of an interactive controller excluding the display and user interfaces can be executed by the interactive application server 352. One or more processes of a component manager controller as described herein can be executed by the component manager controller 353.

[00108] In various embodiments, a component manager controller may be operatively connected to components of a distributed component interleaved wagering system via a network. In other embodiments, a number of other peripheral systems, such as a user management system, a gaming establishment management system, a regulatory system, and/or hosting servers are also operatively connected with the distributed component interleaved wagering systems over a network. Also, other servers can reside outside the bounds of a network within a firewall of the operator to provide additional services for network connected distributed component interleaved wagering systems.

[00109] Although various networked distributed component interleaved wagering systems are described herein, distributed component interleaved wagering systems can be networked in any configuration as appropriate to the specification of a specific application in accordance with embodiments of the invention. In some embodiments, components of a networked distributed component interleaved wagering system, such as an application controller, wager controller, interactive controller, or other servers that perform services for an application controller, wager controller and/or interactive controller, can be networked in different configurations for a specific networked distributed component interleaved wagering system application.

[00110] FIGS. 4A and 4B are diagrams of a structure of an interactive controller of a distributed component interleaved wagering system in accordance with various embodiments of the invention. An interactive controller may be constructed from or configured using one or more processing devices configured to perform the operations of the interactive controller. In many embodiments, an interactive controller can be constructed from or configured using various types of processing devices including, but not limited to, a mobile device such as a smartphone or the like, a personal digital assistant, a wireless device such as a tablet computer or the like, an electronic gaming machine, a personal computer, a gaming console, a set-top box, a computing device, a controller, or the like.

[00111] Referring now to FIG. 4A, an interactive controller 400, suitable for use as interactive controller 120 of FIG. 1, provides an execution environment for an interactive application 402 of a distributed component interleaved wagering system. In several embodiments, an interactive controller 400 of a distributed component interleaved wagering system provides an interactive application 402 that generates an application user interface 404 for interaction with by a user. The interactive application 402 generates a user presentation 406 that is presented to the user through the application user interface 404. The user presentation 406 may include audio features, visual features or tactile features, or any combination of these features. The application user interface 404 further includes one or more human input devices (HIDs) interfaces that communicate with one or more HIDs (e.g., the input devices 514 of FIG. 4b) that the user can use to interact with the distributed component interleaved wagering system. The user's interactions 408 are included by the interactive application 402 in application telemetry data 410 that is communicated by interactive controller 400 to various other components of a distributed component interleaved wagering system as described herein. The interactive application 402 receives application instructions and resources 412 communicated from various other components of a distributed component interleaved wagering system as described herein.

[00112] In some embodiments, various components of the interactive application 402 can read data from an application state 414 in order to provide one or more features of the interactive application. In various embodiments, components of the

interactive application 402 can include, but are not limited to, a physics engine, a rules engine, and/or a graphics engine. The physics engine is used to simulate physical interactions between virtual objects in the interactive application 402. The rules engine implements the rules of the interactive application and a P/RNG that may be used for influencing or determining certain variables and/or outcomes to provide a randomizing influence on the operations of the interactive application. The graphics engine is used to generate a visual representation of the interactive application state to the user. Furthermore, the components may also include an audio engine to generate audio outputs for the user interface.

[00113] During operation, the interactive application reads and writes application resources 416 stored on a data store of the interactive controller host. The application resources 416 may include objects having graphics and/or control logic used to provide application environment objects of the interactive application. In various embodiments, the resources may also include, but are not limited to, video files that are used to generate a portion of the user presentation 406; audio files used to generate music, sound effects, etc. within the interactive application; configuration files used to configure the features of the interactive application; scripts or other types of control code used to provide various features of the interactive application; and graphics resources such as textures, objects, etc. that are used by a graphics engine to render objects displayed in an interactive application.

[00114] In operation, components of the interactive application 402 read portions of the application state 414 and generate the user presentation 406 for the user that is presented to the user using the user interface 404. The user perceives the user presentation and provides user interactions 408 using the HIDs. The corresponding user interactions are received as user actions or inputs by various components of the interactive application 402. The interactive application 402 translates the user actions into interactions with the virtual objects of the application environment stored in the application state 414. Components of the interactive application use the user interactions with the virtual objects of the interactive application and the interactive application state 414 to update the application state 414 and update the user presentation 406 presented to the user. The process loops continuously while the

user interacts with the interactive application of the distributed component interleaved wagering system.

[00115] The interactive controller 400 provides one or more interfaces 418 between the interactive controller 400 and other components of a distributed component interleaved wagering system, such as, but not limited to, an application controller. The interactive controller 400 and the other distributed component interleaved wagering system components communicate with each other using the interfaces. The interface may be used to pass various types of data, and to communicate and receive messages, status data, commands and the like. In certain embodiments, the interactive controller 400 and an application controller communicate application instructions and environment resources 412 and application telemetry data 410. In some embodiments, the communications include requests by the application controller that the interactive controller 400 update the application state 414 using data provided by the application controller.

[00116] In many embodiments, a communication by an application controller includes a request that the interactive controller 400 update one or more resources 416 using data provided by the application controller. In a number of embodiments, the interactive controller 400 provides all or a portion of the application state to the application controller. In some embodiments, the interactive controller 400 may also provide data about one or more of the application resources 416 to the application controller. In some embodiments, the communication includes user interactions that the interactive controller 400 communicates to the application controller. The user interactions may be low level user interactions with the user interface 404, such as manipulation of a HID, or may be high level interactions with game objects as determined by the interactive application. The user interactions may also include resultant actions such as modifications to the application state 414 or game resources 416 resulting from the user's interactions taken in the distributed component interleaved wagering system interactive application. In some embodiments, user interactions include, but are not limited to, actions taken by entities such as non-player characters (NPC) of the interactive application that act on behalf of or under the control of the user.

[00117] In some embodiments, the interactive controller 400 includes a wagering user interface 420 used to communicate distributed component interleaved wagering system telemetry data 422 to and from the user. The distributed component interleaved wagering system telemetry data 422 from the distributed component interleaved wagering system include, but are not limited to, data used by the user to configure Cr, AC and element wagers, and data about the wagering game Cr, AC and element wagers such as, but not limited to, Cr, AC and element balances and Cr, AC and element amounts wagered.

[00118] In some embodiments, the interactive controller includes one or more sensors 424. Such sensors may include, but are not limited to, physiological sensors that monitor the physiology of the user, environmental sensors that monitor the physical environment of the interactive controller, accelerometers that monitor changes in motion of the interactive controller, and location sensors that monitor the location of the interactive controller such as global positioning sensors (GPSs). The interactive controller 400 communicates sensor telemetry data 426 to one or more components of the distributed component interleaved wagering system.

[00119] Referring now to FIG. 4B, interactive controller 400 includes a bus 502 that provides an interface for one or more processors 504, random access memory (RAM) 506, read only memory (ROM) 508, machine-readable storage medium 510, one or more user output devices 512, one or more user input devices 514, and one or more communication interface devices 516.

[00120] The one or more processors 504 may take many forms, such as, but not limited to: a central processing unit (CPU); a multi-processor unit (MPU); an ARM processor; a controller; a programmable logic device; or the like.

[00121] In the example embodiment, the one or more processors 504 and the random access memory (RAM) 506 form an interactive controller processing unit 599. In some embodiments, the interactive controller processing unit includes one or more processors operatively connected to one or more of a RAM, ROM, and machine-readable storage medium; the one or more processors of the interactive controller processing unit receive instructions stored by the one or more of a RAM, ROM, and machine-readable storage medium via a bus; and the one or more

processors execute the received instructions. In some embodiments, the interactive controller processing unit is an ASIC (Application-Specific Integrated Circuit). In some embodiments, the interactive controller processing unit is a SoC (System-on-Chip).

[00122] Examples of output devices 512 include, but are not limited to, display screens; light panels; and/or lighted displays. In accordance with particular embodiments, the one or more processors 504 are operatively connected to audio output devices such as, but not limited to: speakers; and/or sound amplifiers. In accordance with many of these embodiments, the one or more processors 504 are operatively connected to tactile output devices like vibrators, and/or manipulators.

[00123] Examples of user input devices 514 include, but are not limited to: tactile devices including but not limited to, keyboards, keypads, foot pads, touch screens, and/or trackballs; non-contact devices such as audio input devices; motion sensors and motion capture devices that the interactive controller can use to receive inputs from a user when the user interacts with the interactive controller; physiological sensors that monitor the physiology of the user; environmental sensors that monitor the physical environment of the interactive controller; accelerometers that monitor changes in motion of the interactive controller; and location sensors that monitor the location of the interactive controller such as global positioning sensors.

[00124] The one or more communication interface devices 516 provide one or more wired or wireless interfaces for communicating data and commands between the interactive controller 400 and other devices that may be included in a distributed component interleaved wagering system. Such wired and wireless interfaces include, but are not limited to: a Universal Serial Bus (USB) interface; a Bluetooth interface; a Wi-Fi interface; an Ethernet interface; a Near Field Communication (NFC) interface; a plain old telephone system (POTS) interface, a cellular or satellite telephone network interface; and the like.

[00125] The machine-readable storage medium 510 stores machine-executable instructions for various components of the interactive controller, such as but not limited to: an operating system 518; one or more device drivers 522; one or more application programs 520 including but not limited to an interactive application; and

distributed component interleaved wagering system interactive controller instructions 524 for use by the one or more processors 504 to provide the features of an interactive controller as described herein. In some embodiments, the machine-executable instructions further include application control layer/application control interface instructions 526 for use by the one or more processors 504 to provide the features of an application control layer/application control interface as described herein.

[00126] In various embodiments, the machine-readable storage medium 510 is one of a (or a combination of two or more of) a hard drive, a flash drive, a DVD, a CD, a flash storage, a solid state drive, a ROM, an EEPROM, and the like.

[00127] In operation, the machine-executable instructions are loaded into memory 506 from the machine-readable storage medium 510, the ROM 508 or any other storage location. The respective machine-executable instructions are accessed by the one or more processors 504 via the bus 502, and then executed by the one or more processors 504. Data used by the one or more processors 504 are also stored in memory 506, and the one or more processors 504 access such data during execution of the machine-executable instructions. Execution of the machine-executable instructions causes the one or more processors 504 to control the interactive controller 400 to provide the features of a distributed component interleaved wagering system interactive controller as described herein

[00128] Although the interactive controller is described herein as being constructed from or configured using one or more processors and instructions stored and executed by hardware components, the interactive controller can be constructed from or configured using only hardware components in accordance with other embodiments. In addition, although the storage medium 510 is described as being operatively connected to the one or more processors through a bus, those skilled in the art of interactive controllers will understand that the storage medium can include removable media such as, but not limited to, a USB memory device, an optical CD ROM, magnetic media such as tape and disks. In some embodiments, the storage medium 510 can be accessed by the one or more processors 504 through one of the communication interface devices 516 or over a network. Furthermore, any of the

user input devices or user output devices can be operatively connected to the one or more processors 504 via one of the communication interface devices 516 or over a network.

[00129] In some embodiments, the interactive controller 400 can be distributed across a plurality of different devices. In many such embodiments, an interactive controller of a distributed component interleaved wagering system includes an interactive application server operatively connected to an interactive client over a network. The interactive application server and interactive application client cooperate to provide the features of an interactive controller as described herein.

[00130] In various embodiments, the interactive controller 400 may be used to construct other components of a distributed component interleaved wagering system as described herein.

[00131] In some embodiments, components of an interactive controller and an application controller of a distributed component wagering interleaved system may be constructed from or configured using a single device using processes that communicate using an interprocess communication protocol. In other such embodiments, the components of an interactive controller and an application controller of a distributed component wagering interleaved system may communicate by passing messages, parameters or the like.

[00132] In some embodiments, components of an interactive controller, an application controller and a wager controller of a distributed component wagering interleaved system may be constructed from or configured using a single device using processes that communicate using an interprocess communication protocol. In other such embodiments, the components of an interactive controller, an application controller and a wager controller of a distributed component wagering interleaved system may communicate by passing messages, parameters or the like.

[00133] FIGS. 5A and 5B are diagrams of a structure of a wager controller of a distributed component interleaved wagering system in accordance with various embodiments of the invention. A wager controller may be constructed from or configured using one or more processing devices configured to perform the operations of the wager controller. In many embodiments, a wager controller can be constructed from or configured using various types of processing devices including,

but not limited to, a mobile device such as a smartphone or the like, a personal digital assistant, a wireless device such as a tablet computer or the like, an electronic gaming machine, a personal computer, a gaming console, a set-top box, a computing device, a controller, or the like.

[00134] Referring now to FIG. 5A, in various embodiments, a wager controller 604, suitable for use as wager controller 102 of FIG. 1, includes a pseudorandom or random number generator (P/RNG) 620 to produce random results or pseudo random results; one or more paytables 623 which includes a plurality of factors indexed by the random result to be multiplied with an amount of Cr, AC, elements, or objects committed in a wager; and a wagering control module 622 whose processes may include, but are not limited to, generating random results, looking up factors in the paytables, multiplying the factors by an amount of Cr, AC, elements, or objects wagered, and administering one or more Cr, AC, element, or object meters 626. The various wager controller components can interface with each other via an internal bus 625 and/or other appropriate communication mechanism.

[00135] An interface 628 allows the wager controller 604 to operatively connect to an external device, such as one or more application controllers as described herein. The interface 628 provides for receiving of wager data 629 from the external device that is used to specify wager parameters and/or trigger execution of a wager by the wager controller 604. The interface 628 may also provide for communicating wager outcome data 631 to an external device. In numerous embodiments, the interface between the wager controller 604 and other systems/devices may be a wide area network (WAN) such as the Internet. However, other methods of communication may be used including, but not limited to, a local area network (LAN), a universal serial bus (USB) interface, and/or some other method by which two electronic devices could communicate with each other.

[00136] In various embodiments, a wager controller 604 may use a P/RNG provided by an external system. The external system may be connected to the wager controller 604 by a suitable communication network such as a local area network (LAN) or a wide area network (WAN). In some embodiments, the external P/RNG is a central deterministic system that provides random or pseudo random results to one or more connected wager controllers.

[00137] During operation of the wager controller, the external system communicates wager data 629 to the wager controller 604. The wager controller 604 receives the wager data and uses the wager data to trigger execution of a wager in accordance with a wagering proposition. The wager controller 604 executes the wager and determines a wager outcome for the wager. The wager controller communicates wager outcome data 631 of the wager outcome to the external system.

[00138] In some embodiments, the wager controller uses the wager data to select a payable 628 to use and/or an amount of Cr, AC, elements, or objects to wager.

[00139] In some embodiments, the wager outcome data may include, but is not limited to, an amount of Cr, AC, elements, or objects won in the wager.

[00140] In various embodiments, the wager outcome data may include, but is not limited to, an amount of Cr, AC, elements, or objects in the one or more meters 626.

[00141] In some embodiments, the wager outcome data includes state data for the wagering proposition of the executed wager. The state data may correspond to one or more game states of a gambling game that is associated with the wagering proposition. Examples of state data include, but are not limited to, reel strips in an operation state or a final state for a reel-based gambling game, one or more dice positions for a dice-based gambling game, positions of a roulette wheel and roulette ball, position of a wheel of fortune, or the like.

[00142] In various embodiments, the wagering control module 622 determines an amount of a wager and a payable to use from the one or more paytables 623. In such embodiments, in response to the wager data triggering execution of the wager, the wager control module 622 executes the wager by requesting a P/RNG result from the P/RNG 620; retrieving a payable from the one or more paytables 623; adjusting the one or more credit meters 626 for an amount of the wager; applying the P/RNG result to the retrieved payable; multiplying the resultant factor from the payable by an amount wagered to determine a wager outcome; updating the one or more meters 626 based on the wager outcome; and communicating the wager outcome to the external device.

[00143] In various embodiments, an external system communicates a request for a P/RNG result from the wager controller 604. In response, the wager controller 604

returns a P/RNG result as a function of an internal P/RNG or a P/RNG external to the external system to which the wager controller 604 is operatively connected.

[00144] In some embodiments, a communication exchange between the wager controller 604 and an external system relate to the external system support for coupling a P/RNG result to a particular payable contained in the wager controller 604. In such an exchange, the external system communicates to the wager controller 604 as to which of the one or more paytables 623 to use, and requests a result whereby the P/RNG result would be associated with the requested payable 623. The result of the coupling is returned to the external system. In such an exchange, no actual Cr, AC, element, or object wager is conducted, but might be useful in coupling certain non-value wagering interactive application behaviors and propositions to the same final resultant wagering return which is understood for the distributed component interleaved wagering system to conduct wagering.

[00145] In some embodiments, the wager controller 604 may also include storage for statuses, wagers, wager outcomes, meters and other historical events in a storage device 616.

[00146] In some embodiments, an authorization access module provides a process to permit access and command exchange with the wager controller 604 and access to the one or more credit meters 626 for the amount of Cr, AC, elements, or objects being wagered by the user in the distributed component interleaved wagering system.

[00147] In numerous embodiments, communication occurs between various types of a wager controller and an external system 630, such as application controller. In some of these embodiments, the purpose of the wager controller is to allocate wagers to pools, detect occurrences of one or more events upon which the wagers were made, and determine the wager outcomes for each individual wager based on the number of winning wagers and the amount paid into the pool.

[00148] In some embodiments, the wager controller manages accounts for individual users wherein the users make deposits into the accounts, amounts are deducted from the accounts, and amounts are credited to the users' accounts based on the wager outcomes.

[00149] In some embodiments a wager controller is a pari-mutuel wagering system such as used for wagering on an events such as horse races, greyhound races, sporting events and the like. In a pari-mutuel wagering system, user's wagers on the outcome of an event are allocated to a pool. When the event occurs, wager outcomes are calculated by sharing the pool among all winning wagers.

[00150] In various embodiments, a wager controller is a central determination system, such as but not limited to a central determination system for a Class II wagering system or a wagering system in support of a "scratch off" style lottery. In such a wagering system, a player plays against other players and competes for a common prize. In a given set of wager outcomes, there are a certain number of wins and losses. Once a certain wager outcome has been determined, the same wager outcome cannot occur again until a new set of wager outcomes is generated.

[00151] In numerous embodiments, communication occurs between various components of a wager controller 604 and an external system, such as an application controller. In some of these embodiments, the purpose of the wager controller 604 is to manage wagering on wagering events and to provide random (or pseudo random) results from a P/RNG.

[00152] Referring now to FIG. 5B, wager controller 604 includes a bus 732 that provides an interface for one or more processors 734, random access memory (RAM) 736, read only memory (ROM) 738, machine-readable storage medium 740, one or more user output devices 742, one or more user input devices 744, and one or more communication interface and/or network interface devices 746.

[00153] The one or more processors 734 may take many forms, such as, but not limited to, a central processing unit (CPU), a multi-processor unit (MPU), an ARM processor, a controller, a programmable logic device, or the like.

[00154] In the example embodiment, the one or more processors 734 and the random access memory (RAM) 736 form a wager controller processing unit 799. In some embodiments, the wager controller processing unit includes one or more processors operatively connected to one or more of a RAM, ROM, and machine-readable storage medium; the one or more processors of the wager controller processing unit receive instructions stored by the one or more of a RAM, ROM, and machine-readable storage medium via a bus; and the one or more processors

execute the received instructions. In some embodiments, the wager controller processing unit is an ASIC (Application-Specific Integrated Circuit). In some embodiments, the wager controller processing unit is a SoC (System-on-Chip).

[00155] Examples of output devices 742 include, but are not limited to, display screens, light panels, and/or lighted displays. In accordance with particular embodiments, the one or more processors 734 are operatively connected to audio output devices such as, but not limited to speakers, and/or sound amplifiers. In accordance with many of these embodiments, the one or more processors 734 are operatively connected to tactile output devices like vibrators, and/or manipulators.

[00156] Examples of user input devices 734 include, but are not limited to, tactile devices including but not limited to, keyboards, keypads, touch screens, and/or trackballs; non-contact devices such as audio input devices; motion sensors and motion capture devices that the wager controller can use to receive inputs from a user when the user interacts with the wager controller 604.

[00157] The one or more communication interface and/or network interface devices 746 provide one or more wired or wireless interfaces for exchanging data and commands between the wager controller 604 and other devices that may be included in a distributed component interleaved wagering system. Such wired and wireless interfaces include, but are not limited to: a Universal Serial Bus (USB) interface; a Bluetooth interface; a Wi-Fi interface; an Ethernet interface; a Near Field Communication (NFC) interface; a plain old telephone system (POTS) interface; a cellular or satellite telephone network interface; and the like.

[00158] The machine-readable storage medium 740 stores machine-executable instructions for various components of a wager controller, such as but not limited to: an operating system 748; one or more application programs 750; one or more device drivers 752; and distributed component interleaved wagering system wager controller instructions 754 for use by the one or more processors 734 to provide the features of a distributed component interleaved wagering system wager controller as described herein.

[00159] In various embodiments, the machine-readable storage medium 740 is one of a (or a combination of two or more of) a hard drive, a flash drive, a DVD, a CD, a flash storage, a solid state drive, a ROM, an EEPROM, and the like.

[00160] In operation, the machine-executable instructions are loaded into memory 736 from the machine-readable storage medium 740, the ROM 738 or any other storage location. The respective machine-executable instructions are accessed by the one or more processors 734 via the bus 732, and then executed by the one or more processors 734. Data used by the one or more processors 734 are also stored in memory 736, and the one or more processors 734 access such data during execution of the machine-executable instructions. Execution of the machine-executable instructions causes the one or more processors 734 to control the wager controller 604 to provide the features of a distributed component interleaved wagering system wager controller as described herein

[00161] Although the wager controller 604 is described herein as being constructed from or configured using one or more processors and machine-executable instructions stored and executed by hardware components, the wager controller can be composed of only hardware components in accordance with other embodiments. In addition, although the storage medium 740 is described as being operatively connected to the one or more processors through a bus, those skilled in the art of processing devices will understand that the storage medium can include removable media such as, but not limited to, a USB memory device, an optical CD ROM, magnetic media such as tape and disks. In some embodiments, the storage medium 740 can be accessed by the one or more processors 734 through one of the interfaces or over a network. Furthermore, any of the user input devices or user output devices can be operatively connected to the one or more processors 734 via one of the interfaces or over a network.

[00162] In various embodiments, the wager controller 604 may be used to construct other components of a distributed component interleaved wagering system as described herein.

[00163] In some embodiments, components of a wager controller and an application controller of a distributed component wagering interleaved system may be constructed from or configured using a single device using processes that communicate using an interprocess communication protocol. In other such embodiments, the components of a wager controller and an application controller of

a distributed component wagering interleaved system may communicate by passing messages, parameters or the like.

[00164] It should be understood that there may be many embodiments of a wager controller 604 which could be possible, including forms where many modules and components of the wager controller are located in various servers and locations, so the foregoing is not meant to be exhaustive or all inclusive, but rather provide data on various embodiments of a wager controller 604.

[00165] FIG. 6A and 6B are diagrams of a structure of an application controller of a distributed component interleaved wagering system in accordance with various embodiments of the invention. An application controller may be constructed from or configured using one or more processing devices configured to perform the operations of the application controller. In many embodiments, an application controller can be constructed from or configured using various types of processing devices including, but not limited to, a mobile device such as a smartphone, a personal digital assistant, a wireless device such as a tablet computer or the like, an electronic gaming machine, a personal computer, a gaming console, a set-top box, a computing device, a controller, or the like.

[00166] Referring now to FIG. 6A, in many embodiments, an application controller 860, suitable for use as application controller 112 of FIG. 1, manages operation of a distributed component interleaved wagering system, with a wager controller and an interactive controller being support units to the application controller 860. The application controller 860 provides an interface between the interactive application, provided by an interactive controller, and a wagering proposition, provided by a wager controller.

[00167] In some embodiments, the application controller 860 includes an interactive controller interface 800 to an interactive controller. The interactive controller interface 800 provides for communication of data between an interactive controller and the application controller 860, including but not limited to wager telemetry data 802, application instructions and resources 804, application telemetry data 806, and sensor telemetry data 810.

[00168] In various embodiments, the application controller 860 includes a wager controller interface 812 to a wager controller. The wager controller interface 812 provides for communication of data between the application controller 860 and a wager controller, including but not limited to wager outcomes 814 and wager data 816.

[00169] In some embodiments, the application controller 860 includes a component manager controller interface 818 to a component manager controller. The component manager controller interface 818 provides for communication of data between the application controller 860 and a component manager controller, including but not limited to user session control data 820 and user session telemetry data 822.

[00170] The application controller 860 includes a business rule decision engine 824 that receives telemetry data, such as application telemetry data and sensor telemetry data, from an interactive controller. The business rule decision engine 824 uses the telemetry data, along with trigger logic 826 to generate wager data used to trigger a wager in a wager controller.

[00171] In some embodiments, the application telemetry data includes, but is not limited to, application environment variables that indicate the state of an interactive application being used by a user, interactive controller data indicating a state of an interactive controller, and user actions and interactions between a user and an interactive application provided by an interactive controller. The wagering and/or wager data may include, but is not limited to, an amount and type of the wager, a trigger of the wager, and a selection of a payable to be used when executing the wager.

[00172] In some embodiments, the business rule decision engine 824 also receives wager outcome data from a wager controller. The decision engine 824 uses the wager outcome data, in conjunction with telemetry data and application logic 828 to generate application decisions 830 communicated to an application resource generator 832. The application resource generator 832 receives the application decisions and uses the application decisions to generate application instructions and application resources to be communicated to an interactive application.

[00173] In many embodiments, the application controller 860 includes a pseudo random or random result generator used to generate random results that are communicated to the application resource generator 832. The application resource generator uses the random results to generate application instructions and application resources to be communicated to an interactive controller for use by an interactive application.

[00174] In various embodiments, the business rule decision engine 824 also determines an amount of AC to award to a user based at least in part on the user's use of an interactive application of the distributed component interleaved wagering system as determined from application telemetry data. In some embodiments, wager outcome data may also be used to determine the amount of AC that should be awarded to the user.

[00175] In numerous embodiments, an interactive application is a skill-based interactive game and the AC is awarded to the user for the user's skillful play of the skill-based interactive game.

[00176] In some embodiments, the application decisions and wager outcome data are communicated to a wagering user interface generator 834. The wagering user interface generator 834 receives the application decisions and wager outcome data and generates wager telemetry data describing the state of wagering and credit accumulation and loss for the distributed component interleaved wagering system. In some embodiments, the wager telemetry data 146 may include, but is not limited to, amounts of AC and elements earned, lost or accumulated by the user through use of the interactive application as determined from the application decisions, and Cr amounts won, lost or accumulated as determined from the wager outcome data and the one or more credit meters.

[00177] In some embodiments, the wager outcome data 814 also includes data about one or more game states of a gambling game executed in accordance with a wagering proposition by a wager controller. In various such embodiments, the wagering user interface generator 834 generates a gambling game process display and/or gambling game state display using the one or more game states of the gambling game. The gambling game process display and/or gambling game state display is included in wager telemetry data that is communicated to an interactive

controller. The gambling game process display and/or a gambling game state display is displayed by a wagering user interface of the interactive controller to a user. In other such embodiments, the one or more game states of the gambling game are communicated to an interactive controller and a wagering user interface of the interactive controller generates a gambling game process display and/or gambling game state display using the one or more game states of the gambling game for display to a user.

[00178] The application controller 860 can further operatively connect to a wager controller to determine an amount of credit or elements available and other wagering metrics of a wagering proposition. Thus, the application controller 860 may potentially affect an amount of Cr in play for participation in the wagering events of a wagering game provided by the wager controller. The application controller 860 may additionally include various audit logs and activity meters. In some embodiments, the application controller 860 can also couple to a centralized server for exchanging various data related to the user and the activities of the user during game play of a distributed component interleaved wagering system.

[00179] In some embodiments, the operation of the application controller 860 does not affect the provision of a wagering proposition by a wager controller except for user choice parameters that are allowable in accordance with the wagering proposition. Examples of user choice parameters include, but are not limited to: wager terms such as but not limited to a wager amount; speed of game play (for example, by pressing a button or pulling a handle of a slot machine); and/or agreement to wager into a bonus round.

[00180] In a number of embodiments, communication of wager data between a wager controller and the application controller 860 can further be used to communicate various wagering control factors that the wager controller uses as input. Examples of wagering control factors include, but are not limited to, an amount of Cr, AC, elements, or objects consumed per wagering event, and/or the user's election to enter a jackpot round.

[00181] In some embodiments, the application controller 860 utilizes a wagering user interface to communicate certain interactive application data to the user, including but not limited to, club points, user status, control of the selection of user

choices, and messages which a user can find useful in order to adjust the interactive application experience or understand the wagering status of the user in accordance with the wagering proposition in the wager controller.

[00182] In some embodiments, the application controller 860 utilizes a wagering user interface to communicate aspects of a wagering proposition to the user including, but not limited to, odds of certain wager outcomes, amount of Cr, AC, elements, or objects in play, and amounts of Cr, AC, elements, or objects available.

[00183] In a number of embodiments, a wager controller can accept wager proposition factors including, but not limited to, modifications in the amount of Cr, AC, elements, or objects wagered on each individual wagering event, a number of wagering events per minute the wager controller can resolve, entrance into a bonus round, and other factors. In several embodiments, the application controller 860 can communicate a number of factors back and forth to the wager controller, such that an increase/decrease in a wagered amount can be related to the change in user profile of the user in the interactive application. In this manner, a user can control a wager amount per wagering event in accordance with the wagering proposition with the change mapping to a parameter or component that is applicable to the interactive application experience.

[00184] Referring now to FIG. 6B, application controller 860 includes a bus 861 providing an interface for one or more processors 863, random access memory (RAM) 864, read only memory (ROM) 865, machine-readable storage medium 866, one or more user output devices 867, one or more user input devices 868, and one or more communication interface and/or network interface devices 869.

[00185] The one or more processors 863 may take many forms, such as, but not limited to: a central processing unit (CPU); a multi-processor unit (MPU); an ARM processor; a programmable logic device; or the like.

[00186] Examples of output devices 867 include, include, but are not limited to: display screens; light panels; and/or lighted displays. In accordance with particular embodiments, the one or more processors 863 are operatively connected to audio output devices such as, but not limited to: speakers; and/or sound amplifiers. In

accordance with many of these embodiments, the one or more processors 863 are operatively connected to tactile output devices like vibrators, and/or manipulators.

[00187] In the example embodiment, the one or more processors 863 and the random access memory (RAM) 864 form an application controller processing unit 870. In some embodiments, the application controller processing unit includes one or more processors operatively connected to one or more of a RAM, ROM, and machine-readable storage medium; the one or more processors of the application controller processing unit receive instructions stored by the one or more of a RAM, ROM, and machine-readable storage medium via a bus; and the one or more processors execute the received instructions. In some embodiments, the application controller processing unit is an ASIC (Application-Specific Integrated Circuit). In some embodiments, the application controller processing unit is a SoC (System-on-Chip).

[00188] Examples of user input devices 868 include, but are not limited to: tactile devices including but not limited to, keyboards, keypads, foot pads, touch screens, and/or trackballs; non-contact devices such as audio input devices; motion sensors and motion capture devices that the application controller can use to receive inputs from a user when the user interacts with the application controller 860.

[00189] The one or more communication interface and/or network interface devices 869 provide one or more wired or wireless interfaces for exchanging data and commands between the application controller 860 and other devices that may be included in a distributed component interleaved wagering system. Such wired and wireless interfaces include, but are not limited to: a Universal Serial Bus (USB) interface; a Bluetooth interface; a Wi-Fi interface; an Ethernet interface; a Near Field Communication (NFC) interface; a plain old telephone system (POTS), cellular, or satellite telephone network interface; and the like.

[00190] The machine-readable storage medium 866 stores machine-executable instructions for various components of the application controller 860 such as, but not limited to: an operating system 871; one or more applications 872; one or more device drivers 873; and distributed component interleaved wagering system application controller instructions 874 for use by the one or more processors 863 to provide the features of an application controller as described herein.

[00191] In various embodiments, the machine-readable storage medium 870 is one of a (or a combination of two or more of) a hard drive, a flash drive, a DVD, a CD, a flash storage, a solid state drive, a ROM, an EEPROM, and the like.

[00192] In operation, the machine-executable instructions are loaded into memory 864 from the machine-readable storage medium 866, the ROM 865 or any other storage location. The respective machine-executable instructions are accessed by the one or more processors 863 via the bus 861, and then executed by the one or more processors 863. Data used by the one or more processors 863 are also stored in memory 864, and the one or more processors 863 access such data during execution of the machine-executable instructions. Execution of the machine-executable instructions causes the one or more processors 863 to control the application controller 860 to provide the features of a distributed component interleaved wagering system application controller as described herein.

[00193] Although the application controller 860 is described herein as being constructed from or configured using one or more processors and instructions stored and executed by hardware components, the application controller can be composed of only hardware components in accordance with other embodiments. In addition, although the storage medium 866 is described as being operatively connected to the one or more processors through a bus, those skilled in the art of application controllers will understand that the storage medium can include removable media such as, but not limited to, a USB memory device, an optical CD ROM, magnetic media such as tape and disks. Also, in some embodiments, the storage medium 866 may be accessed by processor 863 through one of the interfaces or over a network. Furthermore, any of the user input devices or user output devices may be operatively connected to the one or more processors 863 via one of the interfaces or over a network.

[00194] In various embodiments, the application controller 860 may be used to construct other components of a distributed component interleaved wagering system as described herein.

[00195] In some embodiments, components of a wager controller and an application controller of a distributed component wagering interleaved system may be constructed from or configured using a single device using processes that

communicate using an interprocess communication protocol. In other such embodiments, the components of a wager controller and an application controller of a distributed component wagering interleaved system may communicate by passing messages, parameters or the like.

[00196] In some embodiments, components of an interactive controller and an application controller of a distributed component wagering interleaved system may be constructed from or configured using a single device using processes that communicate using an interprocess communication protocol. In other such embodiments, the components of an interactive controller and an application controller of a distributed component wagering interleaved system may communicate by passing messages, parameters or the like.

[00197] In numerous embodiments, any of a wager controller, an application controller, or an interactive controller as described herein can be constructed from or configured using multiple processing devices, whether dedicated, shared, or distributed in any combination thereof, or can be constructed from or configured using a single processing device. In addition, while certain aspects and features of distributed component interleaved wagering system processes described herein have been attributed to a wager controller, an application controller, or an interactive controller, these aspects and features can be provided in a distributed form where any of the features or aspects can be provided by any of a wager controller, an application controller, and/or an interactive controller within a distributed component interleaved wagering system without deviating from the spirit of the invention.

[00198] FIGS. 7A and 7B are diagrams of a structure of a component manager controller of a distributed component interleaved wagering system in accordance with various embodiments of the invention. A component manager controller may be constructed from or configured using one or more processing devices configured to perform the operations of the component manager controller. In many embodiments, a wager user session can be constructed from or configured using various types of processing devices including, but not limited to, a mobile device such as a smartphone or the like, a personal digital assistant, a wireless device such as a tablet computer or the like, an electronic gaming machine, a personal computer,

a gaming console, a set-top box, a computing device, a controller, a server, or the like.

[00199] Referring now to FIG. 7A, in various embodiments, a component manager controller 1104, suitable for use as component manager controller 150 of FIG. 1, includes a user management and session control module 1106 whose processes may include, but are not limited to, registering users of a distributed component wagering interleaved system, validating users of a distributed component wagering interleaved system using user registration data, managing various types of user sessions for users of the distributed component wagering interleaved system, and the like.

[00200] The component manager controller 1104 may further include a datastore 1108 storing user data used to manage user registration and validation. The component manager controller 1104 may further include a datastore 1110 storing user session data used to manage one or more user sessions.

[00201] The various component manager controller components can interface with each other via an internal bus 1112 and/or other appropriate communication mechanism.

[00202] An interface 1114 allows the component manager controller 1104 to operatively connect to one or more external devices, such as one or more application controllers, wager controllers and/or interactive controllers as described herein. The interface provides for receiving session telemetry data 1116 from the one more external devices. The user session telemetry data includes, but is not limited to, amounts of AC earned by one or more users, requests for entering into a distributed component user session as described herein, and telemetry data regarding the progress of one or more users during a distributed component user session. The interface 1114 may also provide for communicating secession control data 1118 used to manage a user session. In some embodiments, the component manager controller 1104 communicates directly with an interactive controller.

[00203] In numerous embodiments, the interface between the component manager controller and other systems/devices may be a wide area network (WAN) such as the Internet. However, other methods of communication may be used including, but not limited to, a local area network (LAN), a universal serial bus (USB) interface,

and/or some other method by which two electronic devices could communicate with each other.

[00204] During operation of the component manager controller, the external system communicates user session telemetry data to the component manager controller. The component manager controller receives the user session telemetry data and uses the user session telemetry data to generate user session control data as described herein. The component manager controller communicates the user session control data to the external system.

[00205] Referring now to FIG. 7B, component manager controller 1104 includes a bus 1132 that provides an interface for one or more processors 1134, random access memory (RAM) 1136, read only memory (ROM) 1138, machine-readable storage medium 1140, one or more user output devices 1142, one or more user input devices 1144, and one or more communication interface and/or network interface devices 1146.

[00206] The one or more processors 1134 may take many forms, such as, but not limited to, a central processing unit (CPU), a multi-processor unit (MPU), an ARM processor, a controller, a programmable logic device, or the like.

[00207] In the example embodiment, the one or more processors 1134 and the random access memory (RAM) 1136 form a component manager controller processing unit 1199. In some embodiments, the component manager controller processing unit includes one or more processors operatively connected to one or more of a RAM, ROM, and machine-readable storage medium; the one or more processors of the component manager controller processing unit receive instructions stored by the one or more of a RAM, ROM, and machine-readable storage medium via a bus; and the one or more processors execute the received instructions. In some embodiments, the component manager controller processing unit is an ASIC (Application-Specific Integrated Circuit). In some embodiments, the component manager controller processing unit is a SoC (System-on-Chip).

[00208] Examples of output devices 1142 include, but are not limited to, display screens, light panels, and/or lighted displays. In accordance with particular embodiments, the one or more processors 1134 are operatively connected to audio output devices such as, but not limited to speakers, and/or sound amplifiers. In

accordance with many of these embodiments, the one or more processors 1134 are operatively connected to tactile output devices like vibrators, and/or manipulators.

[00209] Examples of user input devices 1144 include, but are not limited to, tactile devices including but not limited to, keyboards, keypads, touch screens, and/or trackballs; non-contact devices such as audio input devices; motion sensors and motion capture devices that the component manager controller can use to receive inputs from a user when the user interacts with the component manager controller 1104.

[00210] The one or more communication interface and/or network interface devices 1146 provide one or more wired or wireless interfaces for exchanging data and commands between the component manager controller 1104 and other devices that may be included in a distributed component interleaved wagering system. Such wired and wireless interfaces include, but are not limited to: a Universal Serial Bus (USB) interface; a Bluetooth interface; a Wi-Fi interface; an Ethernet interface; a Near Field Communication (NFC) interface; a plain old telephone system (POTS) interface; a cellular or satellite telephone network interface; and the like.

[00211] The machine-readable storage medium 1140 stores machine-executable instructions for various components of a component manager controller, such as but not limited to: an operating system 1148; one or more application programs 1150; one or more device drivers 1152; and distributed component interleaved wagering system component manager controller instructions 1154 for use by the one or more processors 1134 to provide the features of a distributed component interleaved wagering system component manager controller as described herein.

[00212] In various embodiments, the machine-readable storage medium 1140 is one of a (or a combination of two or more of) a hard drive, a flash drive, a DVD, a CD, a flash storage, a solid state drive, a ROM, an EEPROM, and the like.

[00213] In operation, the machine-executable instructions are loaded into memory 736 from the machine-readable storage medium 1140, the ROM 1138 or any other storage location. The respective machine-executable instructions are accessed by the one or more processors 1134 via the bus 1132, and then executed by the one or more processors 1134. Data used by the one or more processors 1134 are also stored in memory 1136, and the one or more processors 1134 access such data

during execution of the machine-executable instructions. Execution of the machine-executable instructions causes the one or more processors 1134 to control the component manager controller 1104 to provide the features of a distributed component interleaved wagering system component manager controller as described herein

[00214] Although the component manager controller 1104 is described herein as being constructed from or configured using one or more processors and machine-executable instructions stored and executed by hardware components, the component manager controller can be composed of only hardware components in accordance with other embodiments. In addition, although the storage medium 1140 is described as being operatively connected to the one or more processors through a bus, those skilled in the art of processing devices will understand that the storage medium can include removable media such as, but not limited to, a USB memory device, an optical CD ROM, magnetic media such as tape and disks. In some embodiments, the storage medium 1140 can be accessed by the one or more processors 1134 through one of the interfaces or over a network. Furthermore, any of the user input devices or user output devices can be operatively connected to the one or more processors 1134 via one of the interfaces or over a network.

[00215] In various embodiments, the component manager controller 1104 may be used to construct other components of a distributed component interleaved wagering system as described herein.

[00216] In some embodiments, components of a component manager controller and an application controller of a distributed component wagering interleaved system may be constructed from or configured using a single device using processes that communicate using an interprocess communication protocol. In other such embodiments, the components of a component manager controller and an application controller of a distributed component wagering interleaved system may communicate by passing messages, parameters or the like.

[00217] In some embodiments, components of a component manager controller and a wager controller of a distributed component wagering interleaved system may be constructed from or configured using a single device using processes that communicate using an interprocess communication protocol. In other such

embodiments, the components of a component manager controller and an application controller of a distributed component wagering interleaved system may communicate by passing messages, parameters or the like.

[00218] It should be understood that there may be many embodiments of a component manager controller 1104 which could be possible, including forms where many modules and components of the component manager controller are located in various servers and locations, so the foregoing is not meant to be exhaustive or all inclusive, but rather provide data on various embodiments of a component manager controller 1104.

[00219] In numerous embodiments, any of a wager controller, an application controller, an interactive controller, or a component manager controller as described herein can be constructed from or configured using multiple processing devices, whether dedicated, shared, or distributed in any combination thereof, or can be constructed from or configured using a single processing device. In addition, while certain aspects and features of distributed component interleaved wagering system processes described herein have been attributed to a wager controller, an application controller, an interactive controller, or a component manager controller, these aspects and features can be provided in a distributed form where any of the features or aspects can be provided by any of a component manager controller, a wager controller, an application controller, and/or an interactive controller within a distributed component interleaved wagering system without deviating from the spirit of the invention.

[00220] Although various components of distributed component interleaved wagering systems are discussed herein, distributed component interleaved wagering systems can be configured with any component as appropriate to the specification of a specific application in accordance with embodiments of the invention. In certain embodiments, components of a distributed component interleaved wagering system, such as component manager controller, an application controller, a wager controller, and/or an interactive controller, can be configured in different ways for a specific distributed component interleaved wagering system.

Operation Of distributed component Wagering Interleaved Systems

[00221] FIG. 8 is a sequence diagram of interactions between components of a distributed component interleaved wagering system in accordance with various embodiments of the invention. The components of the distributed component interleaved wagering system include a wager controller 902, such as wager controller 102 of FIG. 1, an application controller 904, such as application controller 112 of FIG. 1, and an interactive controller 906, such as interactive controller 120 of FIG. 1. The process begins with the interactive controller 906 detecting a user performing a user interaction in a user interface of an interactive application provided by the interactive controller 906. The interactive controller 906 communicates application telemetry data 908 to the application controller 904. The application telemetry data includes, but is not limited to, the user interaction detected by the interactive controller 906.

[00222] The application controller 904 receives the application telemetry data 908. Upon determination by the application controller 904 that the user interaction indicates a wagering event, the application controller 904 communicates wager data 912 including a wager request to the wager controller 902. The request for a wager event may include wager terms associated with a wagering proposition.

[00223] The wager controller receives the wager data and uses the wager data to execute (913) a wager in accordance with a wagering proposition. The wager controller 902 communicates a wager outcome 914 of the executed wager to the application controller 904.

[00224] The application controller 904 receives the wager outcome and determines (915) interactive application instructions and resources 916 for the interactive application. The application controller 904 communicates the interactive application instructions and resources 916 to the interactive controller 906. The application controller also communicates wagering telemetry data 920 including the wager outcome to the interactive controller 906.

[00225] The interactive controller 906 receives the interactive application instructions and resources 916 and wagering telemetry data 918. The interactive controller 906 incorporates the received interactive application resources and executes the received interactive application instructions (918). The interactive controller updates (922) an application user interface of the interactive application

provided by the interactive controller using the interactive application instructions and the resources, and updates (922) a wagering user interface using the wagering telemetry data.

[00226] In several embodiments, a user can interact with a distributed component interleaved wagering system by using Cr for wagering in accordance with a wagering proposition along with AC and elements in interactions with an interactive application. Wagering can be executed by a wager controller while an interactive application can be executed by an interactive controller and managed with an application controller.

[00227] FIG. 9 is a collaboration diagram that illustrates how resources such as AC, Cr, elements, and objects are utilized in a distributed component interleaved wagering system in accordance with various embodiments of the invention. The collaboration diagram 1000 illustrates that Cr 1002, interactive application resources including elements and objects 1004 and AC 1006 can be utilized by a user 1008 in interactions with a wager controller 1010, such as wager controller 102 of FIG. 1, an application controller 1012, such as wager controller 112 of FIG. 1, and an interactive controller 1014, such as interactive controller 120 of FIG. 1, of a distributed component interleaved wagering system. The contribution of elements and objects such as included in resources 1004, can be linked to a user's access to credits, such as Cr 1002 and/or AC 1006. Electronic receipt of these credits can come via a smart card, voucher or other portable media, or as received over a network from a server. In some embodiments, these credits can be drawn on demand from a user profile located in a database locally on a distributed component interleaved wagering system or in a remote server.

[00228] A user's actions and/or decisions can affect an interactive application of interactive controller 1014 that consume and/or accumulate AC 1004 and/or resources 1004 in an interactive application executed by an interactive controller 1014, a wager controller 101 and an application controller 1012. The application controller 1012 can monitor the activities taking place within an interactive application executed by an interactive controller 1014 for wagering event occurrences. The application controller 1012 can also communicate the wagering

event occurrences to the wager controller 1010 that triggers a wager of Cr 1002 in accordance with a wagering proposition executed by the wager controller 1010.

[00229] In several embodiments, the user commences interaction with the distributed component interleaved wagering system by contributing credit to a distributed component interleaved wagering system such as, but not limited to, Cr 1002 that may be credit in a real currency or may be credit in a virtual currency that is not fungible with a real currency, AC 1006 that may be application environment credits, and specified types of interactive application elements and/or objects 1004. One or more of these contributions may be provided directly as currency and/or transferred in electronically. Electronic transfer may come via a smart card, voucher or other portable media, or as transferred in over a network from a user data server or distributed component interleaved wagering system component manager controller. In many embodiments, contributions may be drawn on demand from user accounts located in servers residing on the network or in the cloud on a real time basis as the credits, elements and/or object are committed or consumed by the distributed component interleaved wagering system. Generally, Cr is utilized and accounted for by the wager controller 1010; and the resources 1004 and AC 1006 are utilized and accounted for by the application controller 1012 and/or the interactive controller 1014. The user interacts (a) with an interactive application provided by the interactive controller 1014 with the interaction representing an action by the user within the context of the interactive application. The interactive controller 1014 receives the user interaction and communicates (b) the interaction to the application controller 1012. The application controller 1012 receives the interaction and determines from the interaction whether or not a wager should be triggered. If a wager should be triggered, the application controller 1012 communicates (c) wager data about a wager in accordance with a wagering proposition associated with the interaction and thereby triggers a wager. The wager controller receives the wager data and executes the wager in accordance with the wagering proposition, and consumes (d) an appropriate amount of Cr 1002 for the wager. The wager controller 1010 adjusts (e) the Cr 1002 based upon a wager outcome of the wager and communicates (f) the wager outcome to the application controller 1012 as to the outcome of the wager triggered by the application controller 1012. The application

controller 1012 receives the wager outcome. The application controller determines what resources 1004 should be provided to the interactive controller and communicates (g) the resources 1004 to the interactive controller. The interactive controller receives the resources from the application control and integrates them into the execution of the interactive application provided by the interactive controller 1014.

[00230] In some embodiments, the application controller 1012 communicates (h) data about the wager outcome to the interactive controller. The interactive controller receives the wager outcome and displays the wager outcome to the user 1008.

[00231] In some embodiments, the application controller 1012 determines what resources and instructions to provide to the interactive controller 1014 for use by the interactive application provided by the interactive controller 1014 partially on the basis of the wager outcome. In some such embodiments, resources are provided in a case that the wager was a winning wager for the user. In other such embodiments, fewer or no resources are provided in a case of a losing wager.

[00232] In some embodiments, the application controller 1012 determines what resources to provide based on internal logic of the application controller 1012. In some such embodiments, the application controller 1012 employs a random result generator, such as a P/RNG, to generate a random result and the random result is used to determine what resources are provided to the interactive controller 1014.

[00233] In several embodiments, the application controller 1012 determines an increment or a decrement of an amount of AC 1006 using the interactions received from the interactive controller. The increment or decremented amount is communicated (i) to the interactive controller for display to the user.

[00234] In some embodiments, the application controller 1012 executes a wager of Cr as a virtual currency, AC, elements or objects. In some such embodiments, the application controller 1012 employs a random result generator, such as a P/RNG, to generate a random result and the random result is used to determine a wager outcome in Cr as a virtual currency, AC, elements or objects.

[00235] The following is description of an embodiment of the described collaboration where an interactive application provided by an interactive controller of a distributed component interleaved wagering system is a first person shooter game.

The process begins by a user selecting a machine gun to use in the game and then fires a burst of bullets at an opponent. The interactive controller can communicate to the application controller of the user's choice of weapon, that a burst of bullets was fired, and/or the outcome of the burst. The application controller communicates to the wager controller that 3 credits (Cr) are to be wagered on the outcome of a wagering event to match the three bullets consumed. The wager controller then performs the wagering event and determines the result of the wager and may determine the winnings from a payable. The wager controller consumes 3 credits of Cr for the wager and executes the specified wager. By way of example, the wager controller may determine that the user hit a jackpot of 6 credits and returns the 6 credits to the Cr and communicates to the application controller that 3 net credits were won by the user.

[00236] The application controller communicates to the interactive controller to add 3 bullets to an ammunition clip. The interactive controller adds 3 bullets back to the ammo clip. The ammunition may be added by directly adding the ammunition to the clip or by allowing the user to find extra ammunition during use. The application controller logs the new user score (AC) in the game (as a function of the successful hit on the opponent) based on the interactive controller communication, and adds 2 extra points to the user score since a jackpot has been won. The application controller then adds 10 points to the user score (AC) given the success of the hit which in this example is worth 8 points, plus the 2 extra point. Note that this example is only intended to provide an illustration of how credits flow in a distributed component interleaved wagering system, but is not intended to be exhaustive and only lists only one of numerous possibilities of how a distributed component interleaved wagering system may be configured to manage its fundamental credits.

[00237] In many embodiments, component manager controller 1020, such as user account controller 150 of FIG. 1, of a distributed component interleaved wagering system is used to store AC for use of the user. In such an embodiment, AC is generated by the application controller based on the user's use of the distributed component interleaved wagering system and an amount of the AC is communicated to the component manager controller 1020. The component manager controller stores the amount of AC between user sessions. In some embodiments, the

component manager controller communicates an amount of AC to the application controller at the start of a user session for use by the user during a user session.

[00238] A distributed component interleaved wagering system is a software and hardware construct which provides for a regulated and controlled management of intra-jurisdiction and inter-jurisdiction wagering.

[00239] FIG. 10 illustrates components of the distributed component interleaved wagering system according to various embodiments of the invention. In some embodiments, the distributed component interleaved wagering system enables business-to-business interactions to facilitate wagering. FIG. 10 includes patrons and the various members associated with the distributed component interleaved wagering system. In some embodiments, patrons include users and user devices. In some embodiments, members and associated members include application service providers 1206, operators 1210, and financial service providers 1208.

[00240] The distributed component interleaved wagering system includes a component manager controller 1200, which may also be known as an iGEM system, a G.A.M.E. system, a G.A.M.E. controller, or an iGEM MUX. The component manager controller 1200 connects with user devices 1202 via interface 1204. The component manager controller is associated with operators 1210 who are either physically located in a particular geographic location or jurisdiction, such as a state, or are “virtually” located, as allowed by law. In some embodiments, an operator may be virtually located at an IP address, accessible via a network. In some embodiments, the interface 1204 is a provided display, which presents the application service providers 1206, operators 1210, and financial service providers 1208 available to the user. In some embodiments, the interface 1204 is represented by a virtual storefront.

[00241] Each operator 1210 is associated with at least one respective wager controller 1216. Each wager controller 1216 contains the RNGs, meters, primary site controls, and any other elements as required by regulations or law, and is effectively the system where wagers are run. The wager controllers 1216 may be operated by licensed operators 1210. The wager controllers 1216 may be geographically located according to regulations and/or law. In some embodiments,

the wager controllers 1216 are housed in the jurisdiction where the wager is placed. In some embodiments, operators 1210 may have the wager controllers 1216 located within their land based premises. In an example embodiment, if operator 1210a has a land-based premises in Jurisdiction A, the wager controller 1216a associated with operator 1210a may be physically located in the land-based premises in Jurisdiction A.

[00242] Financial service providers 1208 establish and manage merchant accounts and/or user accounts for the operators 1210, and provide for the transfer of funds to/from a user's account to the appropriate financial institutions. In some embodiments, the transfer of funds are executed through the component manager controller 1200. In an example embodiment, the financial service provider 1208 communicates funds to the component manager controller 1200. The component manager controller 1200 receives the funds from the financial service provider 1208. The component manager controller 1200 communicates the funds to the operator 1210. The operator 1210 receives the funds from the component manager controller 1200.

[00243] Application service providers 1206 may be licensed service providers. In some embodiments, the application service providers 1206 operate a website that provides access to the interactive application and provide an interactive application "backplane" for operating various applications on behalf of an operator. In some embodiments, the application service providers 1206 are application publishers. In some embodiments, an application service provider may also be the same entity that operates a wager controller for that site, but it is not a requirement that the application service provider is also an operator.

[00244] The component manager controller 1200 includes two controllers: the routing and audit controller 1220 and the regulatory controller 1222. The routing and audit controller 1220 is responsible for connecting the various components of the system to each other, such as the user devices 1202, the interface 1204, the application services providers 1206, the financial service providers 1208, and the operators 1210, as well as providing for accounting and reporting to each of the

components. The regulatory controller 1222 provides the permissions allowing various components to connect to each other.

[00245] A user may access the component manager controller 1200 using a user device 1202, through an interface 1204. In order to interact with the interface, the user may be required to present authentication credentials. In some embodiments, the user may already be registered or may enter a registration and account creation process in order to create authentication credentials.

[00246] Logic associated with the regulatory controller 1222 of the component manager controller 1200 presents applications and operators to the user that are lawful for the user to use based on rules and regulations. In some embodiments, only those applications and operators that are legal for the user to use are presented. In some embodiments, all application and operators that are available are displayed to the user, but only those that are legal for the user to use may be selected. In some embodiments, those applications and/or operators that are not available for the user to use are not able to be selected. In some embodiments, those applications and/or operators that are not able to be selected are grayed out or otherwise have an indication of being unselectable.

[00247] In some embodiments, once the user is able to access the interface 1204, the user may select an interactive application to use from the interface 1204. Alternatively the user may link to a particular operator's website. In some embodiments, a user may access the interface 1204 in response to an operator's advertising outside the interface 1204, and the user may be routed to the operator's website directly where only interactive applications offered by that operator may be available for use. In some embodiments, the advertising is direct marketing. In some embodiments, the advertising is affiliate advertising.

[00248] In many embodiments, the component manager controller 1200 provides an interface between the interactive application provided by the interactive controller 1212, the application controller 1214, and a wagering proposition provided by the wager controller 1216.

[00249] In some embodiments, the component manager controller 1200 includes an interactive controller interface 1224 to an interactive controller 1212. The

interactive controller interface 1224 provides for the communication of data between the interactive controller and the application controller, including but not limited to wager telemetry data, application instructions and resources, application telemetry data, and sensor telemetry data.

[00250] In various embodiments, the component manager controller 1200 includes a wager controller interface 1226 to a wager controller 1216. The wager controller interface 1226 provides for communication of data between the component manager controller 1200 and the wager controller, including but not limited to wager outcome data and wager data.

[00251] In various embodiments, the component manager controller 1200 includes an application controller interface 1228 to an application controller 1214. The application controller interface 1228 provides for communication of data between the component manager controller 1200 and the application controller, including but not limited to wager telemetry data, application instructions and resources, application telemetry data, sensor telemetry data, wager outcome data and wager data.

[00252] FIGS. 11A-11C illustrate processes involving the distributed component interleaved wagering system according to various embodiments of the invention. In each of the processes, the interactive applications shown are provided by an application service provider on behalf of an operator. The interactive applications may be interactive games. In some embodiments, the interactive games are skill-based games. In some embodiments, the interactive games are chance-based games.

[00253] In FIG. 11A, a user registers with the interface of the distributed component interleaved wagering system, and selects a particular operator from a plurality of operators. The selection may be based on the particular operator's offers. The user uses interactive applications offered on the website of the chosen particular operator.

[00254] In FIG. 11B, the user accesses a website providing interactive applications, under the user's registration. The user decides to use a particular interactive application. The interactive application enables and plays. In this process, the interactive application has been licensed exclusively by a particular operator so the

application is used in the operator's "house." In some embodiments, the interactive application is accessed on servers associated with the operator. The operator may communicate messages to the user.

[00255] In FIG. 11C, a particular interactive application a user wishes to use is offered by more than one operator. In this case, the user selects the interactive application the user wishes to use. The user also selects a particular operator with whose system the user wishes to use. In some embodiments, the decision is based on whether the user already has an account with the operator, or the decision may be based on various offers which the operator may present to the user. If the user does not have an account with a selected operator, then the user may be required to register for an account before commencing use of the interactive application, such as beginning play of an interactive game.

[00256] The component manager controller may serve routing and gatekeeping functions, as well as logging transactions which flow through it for accounting and reporting purposes. FIG. 12 illustrates the distributed component interleaved wagering system according to various embodiments of the invention. Business-to-business and business-to-client service companies and operators are connected to the component manager controller 1300, which may also be known as an iGEM system, a G.A.M.E. system, a G.A.M.E. controller, or an iGEM MUX.

[00257] A system controlled by both the routing and audit controller 1302 and the regulatory controller 1304 allow for the various associated entities to gain access to the distributed component interleaved wagering system via the component manager controller 1300, to communicate with users 1306 and with other associated entities. In some embodiments, the components connected by the component manager controller form an association. The users 1306, interface 1308, application service providers 1314, financial service providers 1316, operators 1312, and wager controllers 1318 are as described herein.

[00258] Various jurisdictional authorities 1310 may also connect to the distributed component interleaved wagering system for access to reporting information 1322, such as e-reporting of revenues and other information of interest to that jurisdiction.

[00259] Connection permissions 1320 may be determined by the regulatory controller 1304 based on licensure, interoperability, and what is allowable under a particular jurisdiction's law.

[00260] A user 1306 connects to the user's player account and an operator 1312 through the component manager controller 1300 based on selections made in the interface 1308, as described herein.

[00261] Financial information necessary to prepare all reporting may be stored in the accounting and audit databases 1326, from which the routing and audit controller may draw in order to produce reporting to all associated members, authorities involved in the compacting, taxing authorities and the regulatory authority.

[00262] In some embodiments, the distributed component interleaved wagering system ensures that only the combinations of approved connections and options 1324 are available to users and associated entities, while restricting those which are not.

[00263] FIGS. 13A and 13B illustrate a number of combinations of applications, operators, and service providers, from a user's perspective. FIG. 13A illustrates a user 1402a present in Jurisdiction A and FIG. 13B illustrates a user 1402b in Jurisdiction B. The choices of interactive applications for the Jurisdiction A user 1402a is greater than those for the Jurisdiction B user 1402b, either due to regulatory registration, or because of policy restrictions for content in that jurisdiction. Jurisdiction B offers the Jurisdiction B user 1402b a greater number of online operators to choose from, while having fewer service providers who have primary wagering system servers located in Jurisdiction B. In some embodiments, the user's options are transparent to the user. In some embodiments, the user sees only the choices of interactive applications and operators available to the user, the choices all conforming to the regulations, policies and laws of any particular jurisdiction. In some embodiments, the regulatory controller 1304 determines the combinations of application service providers 1314, operators 1312, financial service providers 1316, and wager controllers 1318 available to the user.

[00264] In some embodiments, the distributed component interleaved wagering system provides a configurable method to enable a wide variety of business-to-client

and business-to-business relationships likely to occur in an online wagering environment, under the control of a single system which ensures that marketplace members and content are only exposed to users in a jurisdictionally approved manner, and to account for all revenue sharing, taxation accounting and reporting required to assure delivery of financial participation of stakeholders. In some embodiments, the result of using the distributed component interleaved wagering system provides various options for the user, operators, service providers and any other participants in an online wagering market.

[00265] In some embodiments, the distributed component interleaved wagering system provides for establishment of a vibrant interactive application market and is an effective compacting tool for navigating a complex legislative network. In some embodiments, the distributed component interleaved wagering system focuses on commercial aspects as well as compacting (within the bounds of the law). In some embodiments, the distributed component interleaved wagering system provides a significant business opportunity for an early mover that capitalizes on it.

[00266] In some embodiments, if compacting is not utilized, the distributed component interleaved wagering system provides an environment for many companies and content providers seeking to gain access to a market compliant with the jurisdiction's laws.

[00267] In some embodiments, a wagering website includes a wagering controller, an application controller, and an interactive controller providing an interactive application, each as described herein. In some embodiments, the wagering website also includes a merchant account, including, but not limited to: e-wallet functionality, geo-location services, KYP, and player registration.

[00268] In some embodiments, the distributed component interleaved wagering system architecture provides for a jurisdiction-located primary wagering controller. In some embodiments, and to the extent a jurisdiction wishes to compact and there is any disagreement around what a primary wagering system might be, the location of the wager controller may provide a reasonable approach that the intent of the legislation has been met, creating the flexibility to locate other system components in a system such as the component manager controller.

[00269] In an example embodiment, the distributed component interleaved wagering system approach enables compacting where patchwork legislation indicates that Jurisdiction A operators may accept wagers from residents of other jurisdictions where wagering is legal, but dictates that persons within their jurisdiction's borders may only wager on a primary wagering controller located within their own jurisdiction. In the example embodiment, if the wagering chairman of Jurisdiction A does not waive the jurisdiction-based primary wagering controller requirement, then the component manager controller may link to a wager controller located in Jurisdiction A.

Operator and Service Providers Operating in Multiple Jurisdictions

[00270] In some embodiments, the distributed component interleaved wagering system allows a large variety of business-to-business business models while meeting the most stringent compacting requirements regarding operator and primary wagering controller location. In some embodiments, operators under the distributed component interleaved wagering system architecture may be located in any particular jurisdiction, while taking advantage of a wide array of business-to-business arrangements in the distributed component interleaved wagering system marketplace.

[00271] In some embodiments, the distributed component interleaved wagering system enables a wide variety of operating venues and arrangements in a unified way consistent with jurisdiction laws.

Revenue Accounting and Allocation

[00272] In some embodiments, revenue sharing calculations, accounting, and reporting may be highly automated in the distributed component interleaved wagering system, tracking down to the user session level. In some embodiments, the distributed component interleaved wagering system provides an automated auditing tool and a more real time view to revenue for distributed component interleaved wagering system stakeholders.

[00273] In some embodiments, distributed component interleaved wagering system members have a trusted, reliable, and real time accounting and auditing method on revenues and split, improving cash flows and visibility

Navigation of Multiple Taxation Authorities, Each with Different Rules

[00274] In some embodiments, taxation and tax allocation between compacted jurisdictions may benefit from the visibility and automation of tax revenue sharing, which the distributed component interleaved wagering system enables. The real time nature of the visibility to revenues may result in decreased revenue recognition times for the jurisdiction, while supporting complicated multi-tiered tax structures which might result from compacting. In some embodiments, distributed component interleaved wagering system subscribed jurisdictions give nearly instantaneous visibility into taxable revenues.

Multiple Regulatory Regimes for Business-to-Business Companies to Navigate

[00275] In some embodiments, for every jurisdiction in a compact, there may be at least one regulatory regime for service providers to interface with, to legally operate. In an example embodiment, a regulatory opportunity for the distributed component interleaved wagering system is that of a premier regulatory authority to establish itself as a regulator, providing review and certification of members and member associations (members linked to form a complete wagering site). In the example embodiment, the distributed component interleaved wagering system regulator may control the access and exchange permissions structure. This may provide an advantage for many jurisdictions seeking to avoid the burden of having to regulate and monitor all the complexities which can arise with compacted interactive wagering within a country, and may offer a key “one-stop-shop” advantage for licensure of a multi-jurisdiction operating platform.

[00276] In some embodiments, the distributed component interleaved wagering system regulatory monolithic marketplace provides a “lighted pathway” into the online real money wagering world which may be desirable for companies with valuable content and services to offer, but for whom that world is murky, complex to enter and not well understood.

[00277] In some embodiments, the distributed component interleaved wagering system streamlines the regulatory process for jurisdictions and members resulting in more profitable jurisdiction gaming revenues, gaming operations and time to market.

[00278] In some embodiments, the distributed component interleaved wagering system spawns a vibrant business-to-business ecosystem for a wide range of companies and content

Interfacing with Jurisdictions without Highly Developed Regulatory Agencies

[00279] Jurisdictions may not have equally developed regulatory agencies. Land-based operations may be complicated, and regulation across jurisdiction lines may be even more complicated. For smaller jurisdictions, the cost of operations may outweigh potential revenue. In some embodiments, the distributed component interleaved wagering system may be used by jurisdictions to tie in and benefit from a highly regulated, trusted market in exchange for a relatively small service fee out of revenues, as opposed to the significant fixed costs of a properly equipped and staffed regulatory agency. In some embodiments, the distributed component interleaved wagering system may be a potential aggregator of smaller jurisdictions, which in total could produce a market larger than the largest jurisdictions.

[00280] In some embodiments, the distributed component interleaved wagering system may put smaller jurisdictions on a more level footing with larger jurisdictions, and may create a community for such smaller jurisdictions.

[00281] In some embodiments, the primary operators in a number of jurisdictions may be the government of the jurisdiction itself, via a lottery and/or video lottery terminal authorities. These same interests may be the operators of interactive wagering in that jurisdiction. Some of these jurisdictions may have both types of operations, which could effectively end up competing with each other.

[00282] Lotteries may be inexperienced in providing rich game content enticing to users necessary to operate in the interactive wagering space because their offerings may be effectively content-less. In some embodiments, the distributed component interleaved wagering system approach opens up the possibility that one or more of these enterprises could become an operating member of the distributed component interleaved wagering system, opening access to the interactive wagering market. In some embodiments, the distributed component interleaved wagering system home jurisdiction may be in a position to garner revenue from lottery operations.

[00283] If opened for jurisdiction lotto members, the distributed component interleaved wagering system may restrict user funding of an online account in those jurisdictions to use of a convenience/retail store purchased online credit ticket (purchased in the same manner a lottery ticket may be purchased). In some embodiments the ticket may be a cash equivalent certificate allowing a user to fund the user's online wagering account. In some embodiments, the customary participation for a retailer in interactive wagering ticket sales and jackpot wins cuts may be tracked by the interactive wagering certificate tickets.

[00284] In some embodiments, lotteries which are operator members in the distributed component interleaved wagering system may be able to offer their customers extremely high volatility progressive games, yielding much the same experience as scratcher tickets. In an example embodiment, with the lottery authority acting as operator, the bulk of the wagering revenues may end up to the benefit of the jurisdiction. In the example embodiment, existing lottery service providers, likewise, may offer systems for use on the distributed component interleaved wagering system network, and lottery players may be able to access a much richer experience, resulting in increased revenues for the jurisdiction. In the example embodiment, the distributed component interleaved wagering system operator may benefit via service fees.

[00285] In some embodiments, a jurisdiction may have multiple classes of operators or operations, such as a Racino, Card Club, or Native American operations. This diversity of marketplace creates compacting challenges and likely leaves a number of such jurisdictions un-compacted.

[00286] In some embodiments, the distributed component interleaved wagering system provides an opportunity to independent wagering operations. In some embodiments, entities who would normally be unable to mount a competitive online offering may join such a marketplace where they could form member associations with the required providers. The entities may meet jurisdictions' requirements while being able to offer play in the distributed component interleaved wagering system, affording them a desirable interactive wagering operation.

[00287] In some embodiments, the distributed component interleaved wagering system provides a unified storefront, providing a consistent experience and expectation. This uniformity, coupled with the widest available store of interactive applications, all the while bearing the “seal” of a first tier regulatory authority who regulates it, may create player comfort regarding the worthiness of the games and operators in the marketplace.

[00288] In some embodiments, the distributed component interleaved wagering system may provide a way to spawn a number of service providers, which in turn may act as conduits for an increasing range of content to reach the real money wagering market. In some embodiments, the distributed component interleaved wagering system provides the vehicle to open up the tier two game titles market which have smaller followings than name brand titles, in the same manner in which a small games studio may publish in a virtual application store (subject to regulatory approval of the game in the distributed component interleaved wagering system). In the aggregate, these tier two games would have a much larger player base than a handful of tier one titles. This may represent a significant business opportunity segment for the industry.

[00289] In some embodiments, the distributed component interleaved wagering system exchange operations may run under the approval of a regulatory authority who would serve as the exchange’s regulatory master per se. The key functions provided by the regulatory authority may be in the same areas as is the case with traditional wagering systems, along with new areas which were specific to the distributed component interleaved wagering system.

[00290] In terms of taxation, the distributed component interleaved wagering system may provide streamlined reporting functions for revenue earned on a distributed component interleaved wagering system site for a given site, which may be useful for taxation and revenue sharing audit purposes. Reporting may be automatic through an easy to implement accounting interface. In some embodiments, the distributed component interleaved wagering system could prepare and issue to taxing authorities the appropriate tax reporting forms. Financial information necessary to prepare all reporting may be stored in the accounting and

audit databases from which the routing and audit system may draw in order to produce reporting to all associated members, authorities involved in the compacting, taxing authorities and the regulatory authority. Financial reporting may vary greatly depending on where the wagers were made (in a multi-jurisdiction situation), taxes paid in one jurisdiction, operations in other jurisdictions, etc.

[00291] Real Money Gaming Issues Addressed By Various Embodiments Of The Invention

[00292] In various embodiments, the distributed component interleaved wagering system may address particular issues.

[00293] Some jurisdictions may require that any online operations occur under the license of a land based operator. A jurisdiction may require the primary wagering systems be casino resident. That is, the hardware and software components of a wagering controller including a random number generator and paytables must reside within a land-based casino.

[00294] Some jurisdictions may require that the primary wagering systems be jurisdiction resident. That is, the hardware and software components of a wagering controller including a random number generator and paytables must reside within the jurisdiction.

[00295] Certain publishers may not allow real money gaming (RMG) (and possibly social gaming) applications on their stores.

[00296] A user may load the user device through a website other than a website dedicated to that type of device, but the process is intentionally difficult and scares many consumers away (~50%) from the “unauthorized app.” To avoid the difficult app loading system, and subsequent warnings on such devices, the app must be signed by an authorized publisher or by an authorized publisher’s agent or party (which may be the distributed component interleaved wagering system).

[00297] A publisher may not allow payment for RMG to process through the publishers’ sites, but may allow RMG or gambling apps on the publisher’s websites for download.

[00298] In some embodiments, some devices may only load content through a single publisher's website.

[00299] In various embodiments, each game publisher may have their own wallets that are connected in a cohesive manner. In some embodiments, virtual credit may be connected to real credits, such that virtual credits may be exchanged for real credits and wagered.

[00300] In many embodiments, player data which may be brought in via a publisher is confidentially handled.

[00301] In various embodiments, game publishers and affiliates may be treated as different classes of service providers.

[00302] In some embodiments, gaming revenue is allocated to content providers and publishers as members of a content provider class.

[00303] In many embodiments, not all interactive applications may be allowable in all jurisdictions. The reasons that an interactive application may be excluded from a jurisdiction include, but are not limited to: thematic appropriateness and acceptable application mechanics.

[00304] In various embodiments, certain jurisdictions may require that anything which is involved in the wagering process (direct trigger and outcome display) is controlled by a licensed entity. Certain interactive applications may have mechanics which operate in each of the two domains (commercial & regulated).

[00305] FIG. 14 is an illustration of a distributed component interleaved wagering system in accordance with embodiments of the invention. As illustrated, a component manager controller 1502 provides coupling between publishers 1504, distributors and application sites 1506. The component manager controller 1502 may also be known as an iGEM system, a G.A.M.E. system, a G.A.M.E. controller, or an iGEM MUX. One or more publishers 1504 (as indicated by P1 through PN) provide content for use in either wagering applications, such as skill with interleaved wagering games, or skill games without wagering games for use with the distributed component interleaved wagering system. In turn, one or more distributors 1506, (as indicated by D1 through DN) distribute the provided application content. One or

more application sites 1508 operated by one or more operators (as indicated by Operator 1 through Operator N) provide the applications to the users. The component manager controller 1502 is coupled to one or more financial service providers 1514 that provide financial services to the users of the interactive applications. The financial services include, but are not limited to: providing e-wallets for the funding of the applications used by the users. One or more interactive wagering controllers 1516 are located physically in various jurisdictions (as indicated by lines between the wager controllers and the map) and are coupled to applications provided by the one or more operators on the one or more sites. The distributed component interleaved wagering system operates as an application distribution gate (jurisdictional fencing, app signing), as a payment facilitator (super PSP), provides for interstitial wallets (transfer from distributed component interleaved wagering system wallet to operator wallet), operates as a currency and wallet exchange (RC, VC, GWC), provides revenue sharing, accounting and distribution, provides for taxation accounting, provides for game world (GW) credit (GWC) species exchange (GWC' -> GWC'' -> GWC'), provides for a GWC funding system, and operates as a GWC bank.

[00306] FIG. 15 is a sequence diagram of interactions between components of a distributed component interleaved wagering system in accordance with various embodiments of the invention. The system includes an interactive controller 1602, an application controller 1604, a wager controller 1606, and a component manager controller 1608, each as described herein. The interactive controller 1602 provides an interactive application. In some embodiments, the interactive application is an interactive game. In some embodiments, the interactive game is a skill-based game. In some embodiments, the interactive game is a chance-based game.

[00307] The component manager controller 1608 is operatively connected to associated members of the distributed component interleaved wagering system. The associated members may include application service providers, financial service providers, or operators. In some embodiments, the application service providers provide the application controller 1604. In some embodiments, the operators are associated with the wager controller 1606. In some embodiments, the operators provide the wager controller 1606.

[00308] The component manager controller 1608 determines allowable combinations of components (1608). In an example embodiment, the component manager controller 1608 is connected to one or more application service providers, one or more operators, and one or more financial service providers. Each of the service providers, operators, and financial service providers may have associated conditions that limit the compatibility between the other components. In some embodiments, the determination is made whenever a component is added to the distributed component interleaved wagering system. In some embodiments, the determination is made by a routing and audit controller.

[00309] The interactive controller 1602 communicates an initialization indication to the component manager controller 1608 (1612). The initialization indication may be triggered by a user indicating on a user device to begin an interactive application session. The component manager controller 1608 receives the initialization indication from the interactive controller 1602 (1612).

[00310] The component manager controller 1608 determines the components that are accessible to the interactive controller 1602 (1614). In some embodiments, the determination is based on the geographic location of the interactive controller 1602 or the user. An example embodiment of accessibility of components is illustrated in FIGS. 13A and 13B.

[00311] The component manager controller 1608 communicates, to the interactive controller 1602, an identification of accessible components (1616). In some embodiments, the identification of accessible components also indicates components that are not accessible, along with a reason why the component is not accessible.

[00312] The interactive controller 1602 receives, from the component manager controller 1608, the identification of accessible components (1616). The interactive controller 1602 presents the accessible components to the user, and receives an identification from the user of components the user would like to use. In an example embodiment, the interactive controller 1602 may present to the user, as available components, operators X, Y, and Z and service providers A, B, and C. The user may select operator X and service provider B to use in an interactive application session.

[00313] The interactive controller 1602 communicates, to the component manager controller 1608 the identification of chosen components to use in the interactive application session (1618). The component manager controller 1608 receives, from the interactive controller 1602, an identification of chosen components (1618). In some embodiments, the application controller 1604 and/or the wager controller 1606 are identified based on the identification of chosen components.

[00314] The interactive controller 1602 communicates, to the component manager controller 1608, application telemetry (1618). The component manager controller 1608 receives, from the interactive controller 1602, the application telemetry (1618). The component manager controller 1608 communicates, to the application controller 1604, the application telemetry (1622). The application controller 1604 receives, from the component manager controller 1608, the application telemetry (1622). In some embodiments, the application telemetry is communicated from the interactive controller 1602 to the application controller 1604 via the component manager controller 1608 so that the application telemetry may be tracked. In some embodiments, the component manager controller 1608 communicates an identification of the application controller to the interactive controller so that they may communicate directly.

[00315] The application controller 1604 determines whether a wager request should be triggered. When the application controller 1604 determines, based on the application telemetry, that a wager request should be triggered, the application controller 1604 communicates, to the component manager controller 1608, a wager request (1624). The component manager controller 1608 receives, from the application controller 1604, the wager request (1624). In some embodiments, the component manager controller 1608 records information based on the wager request. In some embodiments, the number of wager requests communicated from the application controller 1604 is recorded. In some embodiments, the number of wager requests associated with the interactive controller 1602 is recorded.

[00316] The component manager controller 1608 communicates, to the wager controller 1606, the wager request (1626). The wager controller 1606 receives, from the component manager controller 1608, the wager request (1626). The wager controller 1606, based on the received wager request, generates a wager outcome.

[00317] The generated wager outcome is communicated from the wager controller 1606 to the component manager controller 1608 (1628). The component manager controller 1608 receives the wager outcome from the wager controller 1606 (1628). The component manager controller 1608 may record information based on the wager outcome. In some embodiments, wager outcomes associated with the wager controller 1606 and/or the application controller 1604 and/or the interactive controller 1602 may be recorded.

[00318] The component manager controller 1608 communicates the wager outcome to the application controller 1604 (1630). The application controller 1604 receives, from the component manager controller 1608, the wager outcome (1630). The application controller 1604, based on the received wager outcome, determines whether application resources should be awarded.

[00319] The application controller 1604 communicates, to the component manager controller 1608 application resources (1632). The component manager controller 1608 receives, from the application controller 1604, the application resources (1632). The component manager controller 1608 communicates, to the interactive controller 1602, the application resources (1634). The interactive controller 1602 receives, from the component manager controller 1608, the application resources (1634).

[00320] In some embodiments, the component manager controller 1608 serves as a router of information between the associated components of the distributed component interleaved wagering system. That is, the component manager controller 1608 receives information from one component and communicates the information to another component.

[00321] In some embodiments, components communicate directly, and the component manager controller 1608 informs the components of the location of other components.

[00322] In an example embodiment, an interactive controller 1602 communicates, to the component manager controller 1608, an initialization indication. The initialization indication may be associated with the beginning of an interactive application session and may include information associated with the interactive controller 1602. The component manager controller 1608 receives, from the interactive controller 1602, the initialization indication. The component manager

controller 1608 determines, based on the received initialization indication, components that are accessible to the interactive controller 1602.

[00323] The component manager controller 1608 communicates, to the interactive controller 1602, an identification of the accessible components. The interactive controller 1602 receives, from the component manager controller 1608, the identification of the accessible components. The interactive controller 1602 may present the accessible components to a user, and receive, from the user, an identification of chosen components. The interactive controller 1602 communicates, to the component manager controller 1608, the identification of chosen components.

[00324] The component manager controller 1608 receives the identification of chosen components. The component manager controller 1608 communicates, to the interactive controller, the location of the application controller 1604. In some embodiments, the location of the application controller 1604 is a virtual address accessible via a network, such as an internet protocol (IP) address. The component manager controller 1608 also communicates, to the application controller 1604, the location of the wager controller 1606. In some embodiments, the location of the wager controller 1606 is a virtual address accessible via a network, such as an IP address.

[00325] The interactive controller 1602 receives, from the component manager controller 1608, the location of the application controller 1604. The application controller 1604 receives, from the component manager controller 1608, the location of the wager controller 1606.

[00326] The interactive controller 1602 communicates, to the application controller 1604, application telemetry. The application controller 1604 receives, from the interactive controller 1602, the application telemetry. Based on the received application telemetry, the application controller determines whether a wager is triggered. When a wager is triggered, the application controller 1604 communicates, to the wager controller 1606, a wager request. The wager controller 1606 receives, from the application controller 1604, the wager request. The wager controller 1606 generates a wager outcome based on the wager request and communicates the wager outcome to the application controller 1604. The application controller 1604 receives, from the wager controller 1606, the wager outcome. The application

controller 1604 generates, based on the received wager outcome, application resources, and communicates the generated application resources to the interactive controller 1602. The interactive controller 1602 receives the application resources from the application controller 1604.

[00327] In another example embodiment, an interactive controller 1602 communicates, to the component manager controller 1608, an initialization indication. The initialization indication may be associated with the beginning of an interactive application session and may include information associated with the interactive controller 1602. The component manager controller 1608 receives, from the interactive controller 1602, the initialization indication. The component manager controller 1608 determines, based on the received initialization indication, components that are accessible to the interactive controller 1602.

[00328] The component manager controller 1608 communicates, to the interactive controller 1602, an identification of the accessible components. The interactive controller 1602 receives, from the component manager controller 1608, the identification of the accessible components. The interactive controller 1602 may present the accessible components to a user, and receive, from the user, an identification of chosen components. The interactive controller 1602 communicates, to the component manager controller 1608, the identification of chosen components.

[00329] The component manager controller 1608 receives the identification of chosen components. The component manager controller 1608 communicates, to the interactive controller 1602, the location of the application controller 1604. In some embodiments, the location of the application controller 1604 is a virtual address accessible via a network, such as an internet protocol (IP) address. The component manager controller 1608 also communicates, to the application controller 1604 and the wager controller 1606, an indication that a session has been created involving the interactive controller 1602, the application controller 1604, and the wager controller 1606. In some embodiments, the indication that a session has been created includes the locations of the interactive controller 1602, the application controller 1604, and the wager controller 1606.

[00330] The interactive controller 1602 communicates, to the application controller 1604, application telemetry. The application controller 1604 receives, from the

interactive controller 1602, the application telemetry. Based on the received application telemetry, the application controller determines whether a wager is triggered. When a wager is triggered, the application controller 1604 communicates, to the wager controller 1606, a wager request. The wager controller 1606 receives, from the application controller 1604, the wager request. The wager controller 1606 generates a wager outcome based on the wager request and communicates the wager outcome to the application controller 1604. The application controller 1604 receives, from the wager controller 1606, the wager outcome. The application controller 1604 generates, based on the received wager outcome, application resources, and communicates the generated application resources to the interactive controller 1602. The interactive controller 1602 receives the application resources from the application controller 1604.

[00331] FIG. 16 is a sequence diagram of interactions between components of a distributed component interleaved wagering system in accordance with various embodiments of the invention. The system includes an application service provider 1702, an operator 1704, a financial service provider 1706, a jurisdictional authority 1708, and a component manager controller 1710, each as described herein. The operator 1704 may be associated with a wager controller. In some embodiments, the interactions in FIG. 16 occur prior to receiving an initialization indication from an interactive controller (e.g., step 1612 of FIG. 15). In some embodiments, the interactions in FIG. 16 occur continuously, as additional components, such as application service providers, operators, financial service providers, and jurisdictional authorities connect to the component manager controller 1710.

[00332] The application service provider 1702 communicates, to the component manager controller 1710, application service provider information (1712). The application service provider information may include the location of the application service provider 1702. The application service provider information may also include identifications of interactive applications that may be provided by the application service provider 1702.

[00333] The component manager controller 1710 receives, from the application service provider 1702, the application service provider information (1712). The

component manager controller 1710 determines allowable combinations of components based on the received application service provider information (1714).

[00334] The operator 1704 communicates, to the component manager controller 1710, operator information (1716). The operator information may include the location of the operator 1704. The operator information may also include the location of one or more wager controllers associated with the operator 1704.

[00335] The component manager controller 1710 receives, from the operator 1704, the operator information (1716). The component manager controller 1710 determines allowable combinations of components based on the received operator information (1716).

[00336] The financial service provider 1706 communicates, to the component manager controller 1710, financial service provider information (1720). The financial service provider information may include the location of the financial service provider 1706. The financial service provider information may also include services associated with the financial service provider 1706.

[00337] The component manager controller 1710 receives, from the financial service provider 1706, the financial service provider information (1720). The component manager controller 1710 determines allowable combinations of components based on the received financial service provider information (1722).

[00338] The jurisdictional authority 1708 communicates, to the component manager controller 1710, jurisdictional authority information (1724). The jurisdictional authority information may include regulations associated with the particular jurisdiction.

[00339] The component manager controller 1710 receives, from the jurisdictional authority 1708, the jurisdictional authority information (1724). The component manager controller 1710 determines allowable combinations of components based on the received jurisdictional authority information (1726).

[00340] While the above description may include many specific embodiments of the invention, these should not be construed as limitations on the scope of the invention, but rather as examples of embodiments thereof. It is therefore to be understood that the present invention can be practiced otherwise than specifically described, without departing from the scope and spirit of the present invention.

Thus, embodiments of the present invention described herein should be considered in all respects as illustrative and not restrictive. Elements in figures labeled with letters after numbers (e.g., 10a, 10b, and 10c) may be referred to collectively by the number only (e.g., 10).

What is Claimed:

1. A distributed component interleaved wagering system, comprising:
 - an interactive controller operatively connected to a component manager controller, the interactive controller constructed to:
 - communicate, to the component manager controller, an initialization indication;
 - receive, from the component manager controller, an identification of accessible components, wherein the accessible components are components available for use with the interactive controller;
 - communicate, to the component manager controller, application telemetry and an identification of chosen components from the identification of accessible components, wherein the identification of chosen components comprise an identification of a wager controller and an identification of an application controller; and
 - receive, from the component manager controller, application resources based on the communicated application telemetry;
 - the identified wager controller operatively connected to the component manager controller, the identified wager controller constructed to communicate, to the component manager controller, a generated wager outcome, the generated wager outcome based on a wager request received from the component manager controller; and
 - the identified application controller operatively connected to the component manager controller, the identified application controller constructed to:
 - receive, from the component manager controller, application telemetry received from the interactive controller;
 - communicate, to the component manager controller, the wager request generated based on the received application telemetry;
 - receive, from the component manager controller, the wager outcome generated by the wager controller based on the wager request; and
 - communicate, to the component manager controller, the application resources generated based on the wager outcome.

2. The distributed component interleaved wagering system of Claim 1, wherein the component manager controller is constructed to:
 - receive, from the interactive controller, the initialization indication;
 - determine, based on the initialization indication, the accessible components;
 - communicate, to the interactive controller, the identification of accessible components;
 - receive, from the interactive controller, the application telemetry and identification of chosen components; and
 - communicate, to the interactive controller, the application resources.

3. The distributed component interleaved wagering system of Claim 2, wherein the component manager controller is further constructed to:
 - communicate, to the identified application controller, based on the received identification of chosen components, the application telemetry;
 - receive, from the identified application controller, the wager request;
 - communicate, to the identified wager controller, based on the received identification of chosen components, the wager request;
 - receive, from the identified wager controller, the wager outcome;
 - communicate, to the identified application controller, the wager outcome; and
 - receive, from the identified application controller, the application resources.

4. The distributed component interleaved wagering system of Claim 1, wherein the component manager controller is constructed to:
 - receive, from a component connected to the component manager controller, information associated with the component; and
 - determine, based on the received information associated with the component, allowable combinations of components connected to the component manager controller.

5. The distributed component interleaved wagering system of Claim 4, wherein the component manager controller is operatively connected to a jurisdictional

authority, wherein the jurisdictional authority is constructed to communicate, to the component manager controller, accessibility rules; and

wherein the determination of allowable combinations of components connected to the component manager controller is based on the accessibility rules.

6. The distributed component interleaved wagering system of Claim 1, wherein the component manager controller is connected to an accounting and audit database, wherein the accounting and audit database records fund transactions associated with the distributed component interleaved wagering system; and

wherein an accounting and audit report may be generated based on the accounting and audit database.

7. The distributed component interleaved wagering system of Claim 1, wherein the interactive controller is further constructed to:

provide a display, to a user, comprising the identified accessible components; and

receive, from the user, the identification of chosen components.

8. A networked component manager controller of a distributed component interleaved wagering system, comprising:

an interactive controller interface operatively connecting the component manager controller to an interactive controller of the distributed component interleaved wagering system;

a wager controller interface operatively connecting the component manager controller to a wager controller of the distributed component interleaved wagering system;

an application controller interface operatively connecting the component manager controller to an application controller of the distributed component interleaved wagering system; and

one or more processors constructed to:

receive, from an interactive controller, an initialization indication;

determine accessible components, wherein the accessible components are components available for use with the interactive controller;

communicate, to the interactive controller, an identification of the accessible components;

receive, from the interactive controller, application telemetry and an identification of chosen components from the identification of accessible components, wherein the identification of chosen components comprise an identification of the wager controller and an identification of the application controller;

communicate, to the application controller, the application telemetry;

receive, from the application controller, a wager request based on the application telemetry;

communicate, to the wager controller, the wager request;

receive, from the wager controller, a wager outcome based on the wager request;

communicate, to the application controller, the wager outcome;

receive, from the application controller, application resources based on the wager outcome; and

communicate, to the interactive controller, the application resources.

9. The networked component manager controller of Claim 8, wherein the one or more processors are further constructed to:

receive, from a component connected to the component manager controller, information associated with the component; and

determine, based on the received information associated with the component, allowable combinations of components connected to the component manager controller.

10. The networked component manager controller of Claim 9, wherein the component manager controller is operatively connected to a jurisdictional authority, wherein the jurisdictional authority is constructed to communicate, to the component manager controller, accessibility rules; and

wherein the determination of allowable combinations of components connected to the component manager controller is based on the accessibility rules.

11. The networked component manager controller of Claim 8, wherein the component manager controller is connected to an accounting and audit database, wherein the accounting and audit database records fund transactions associated with the distributed component interleaved wagering system; and

wherein an accounting and audit report may be generated based on the accounting and audit database.

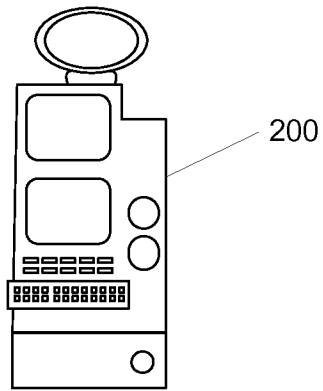

FIG. 2A

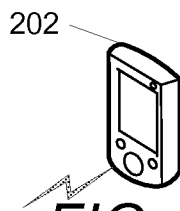

FIG. 2B

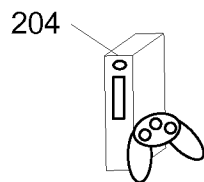

FIG. 2C

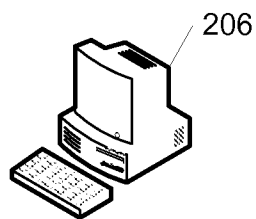

FIG. 2D

3/21

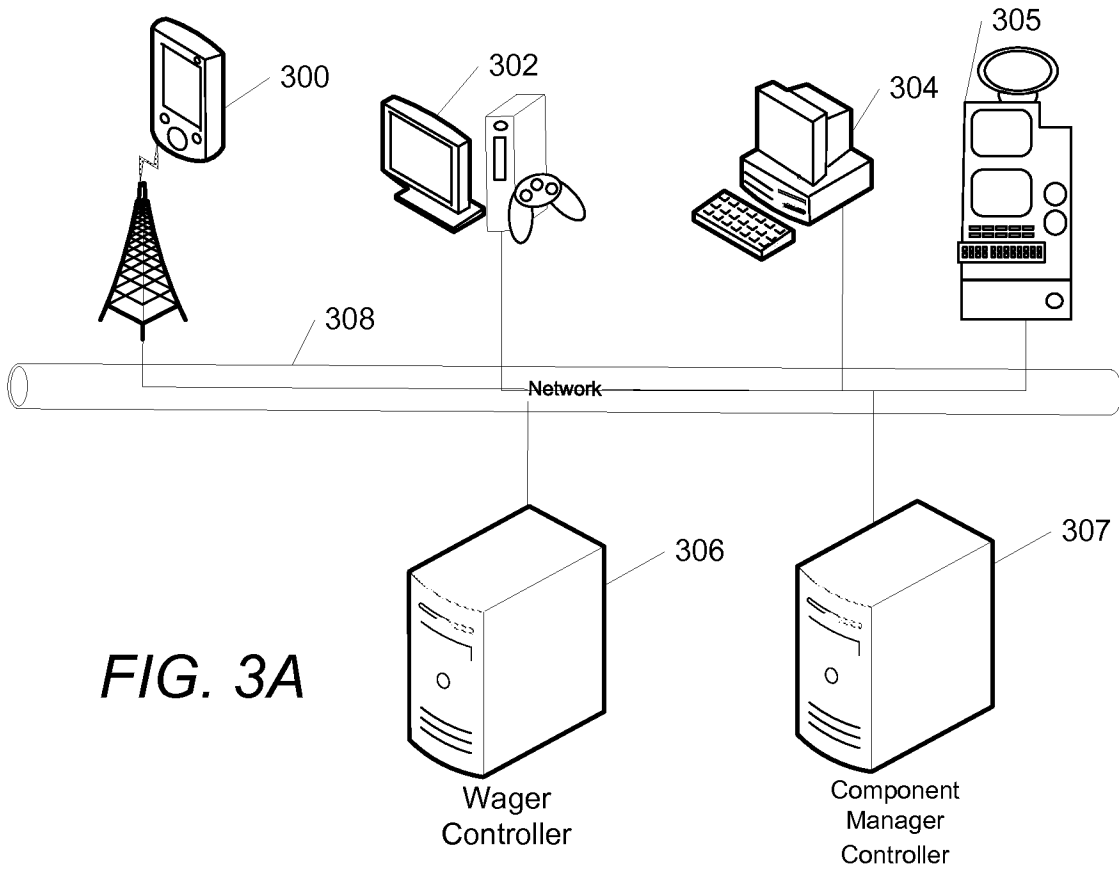

FIG. 3A

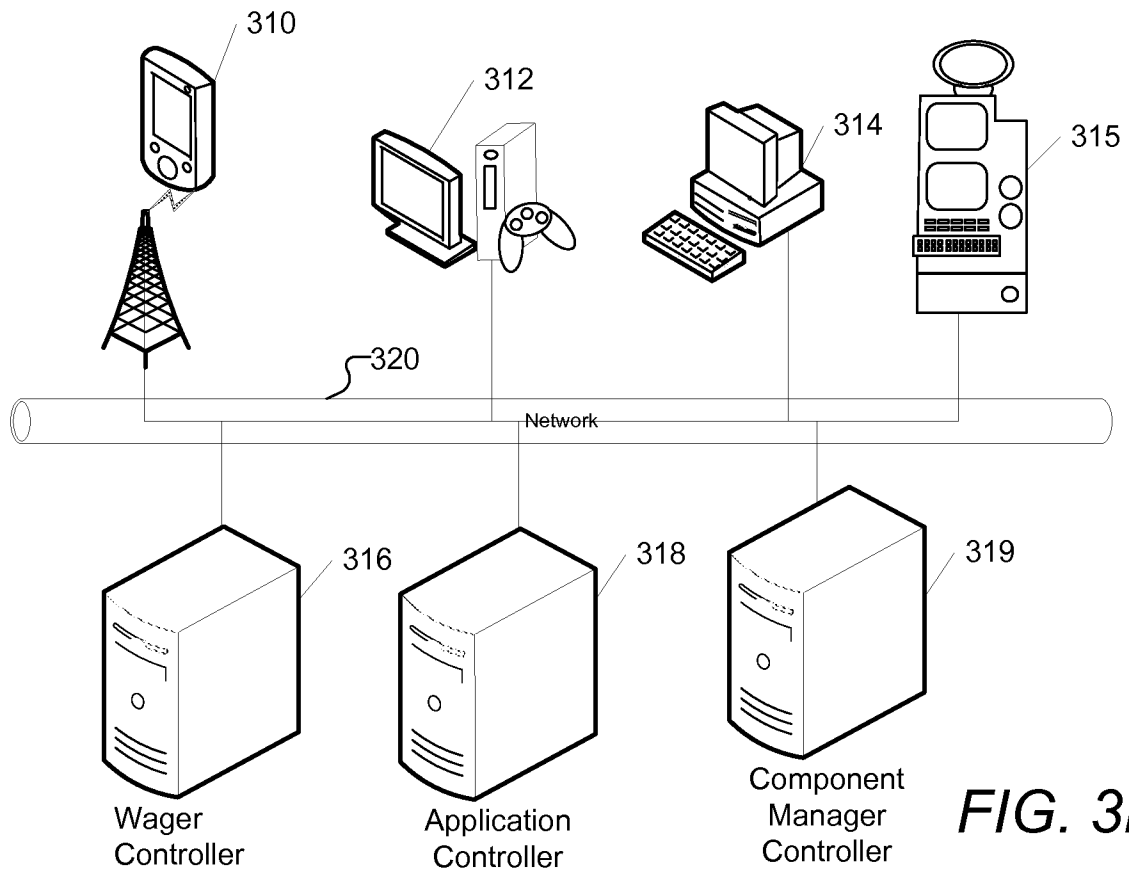

FIG. 3B

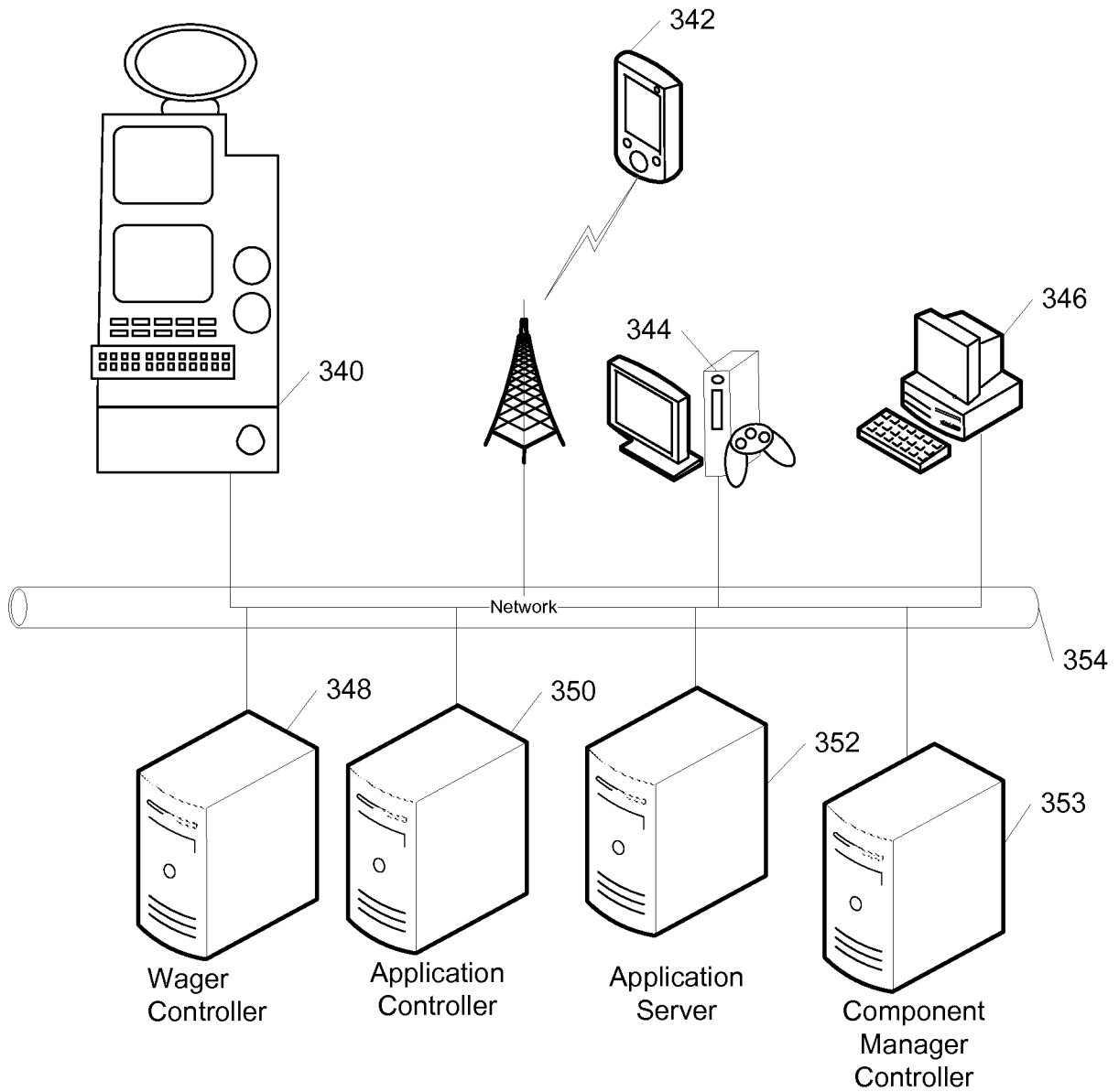

FIG. 3C

5/21

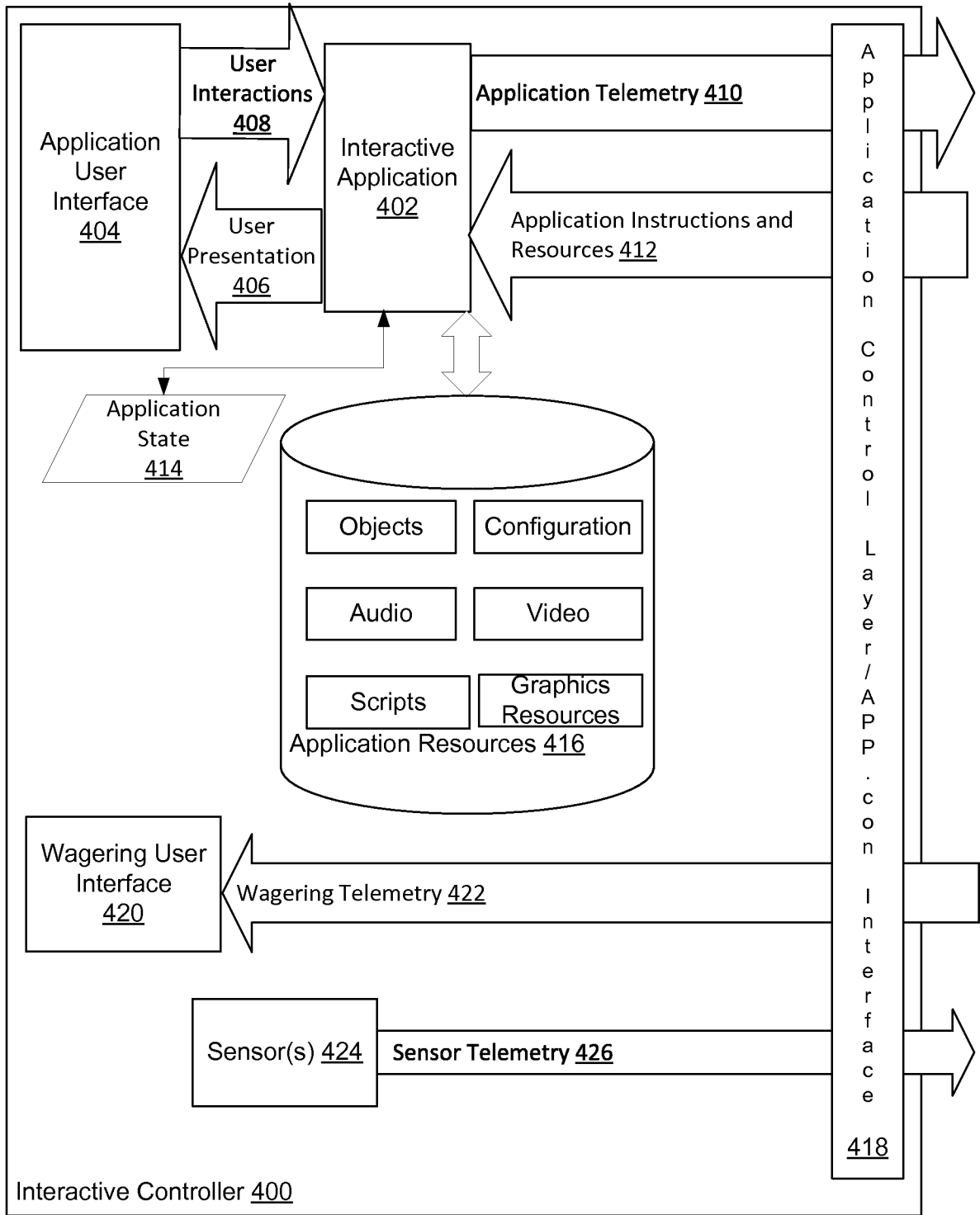

FIG. 4A

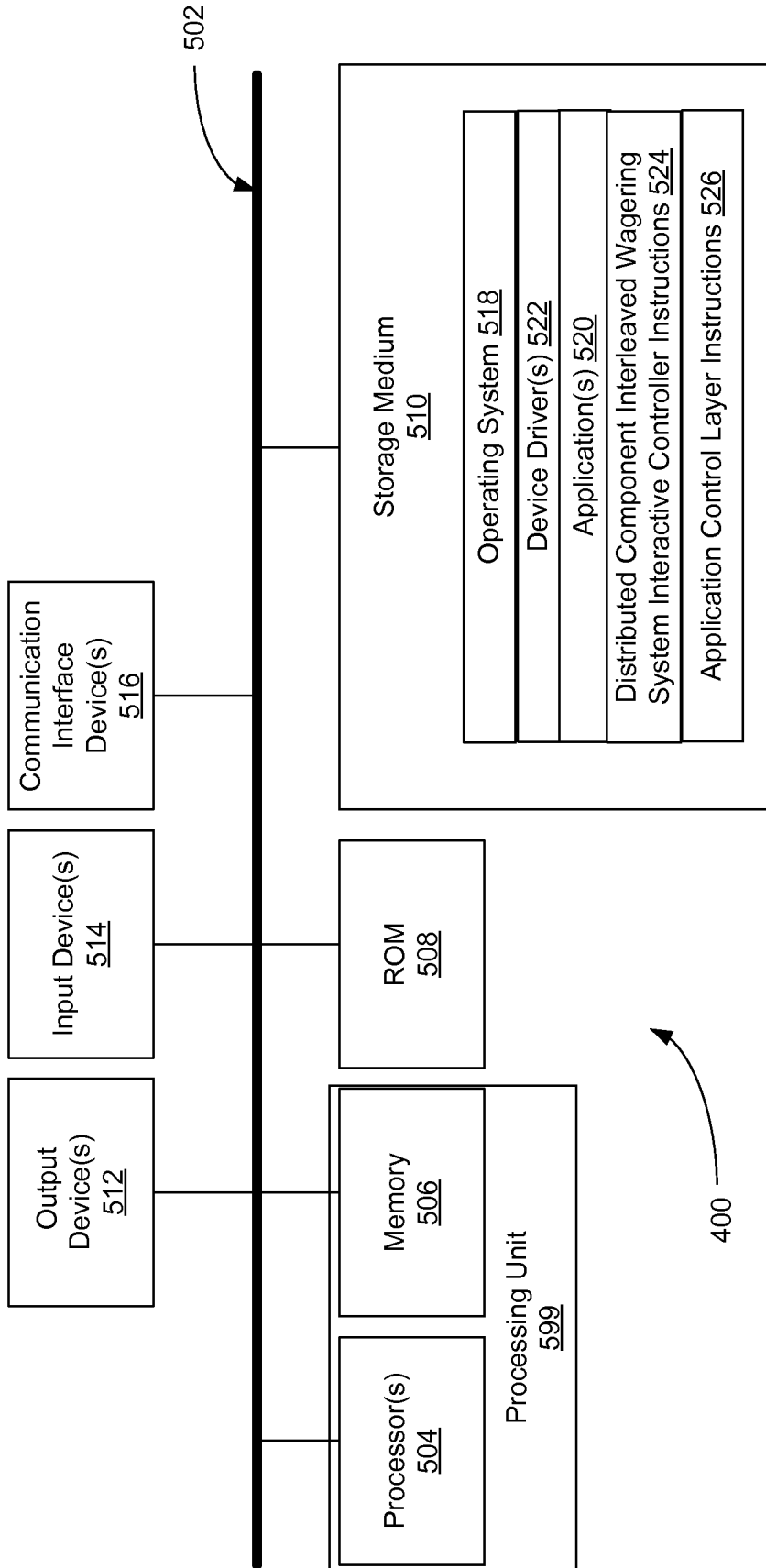

FIG. 4B

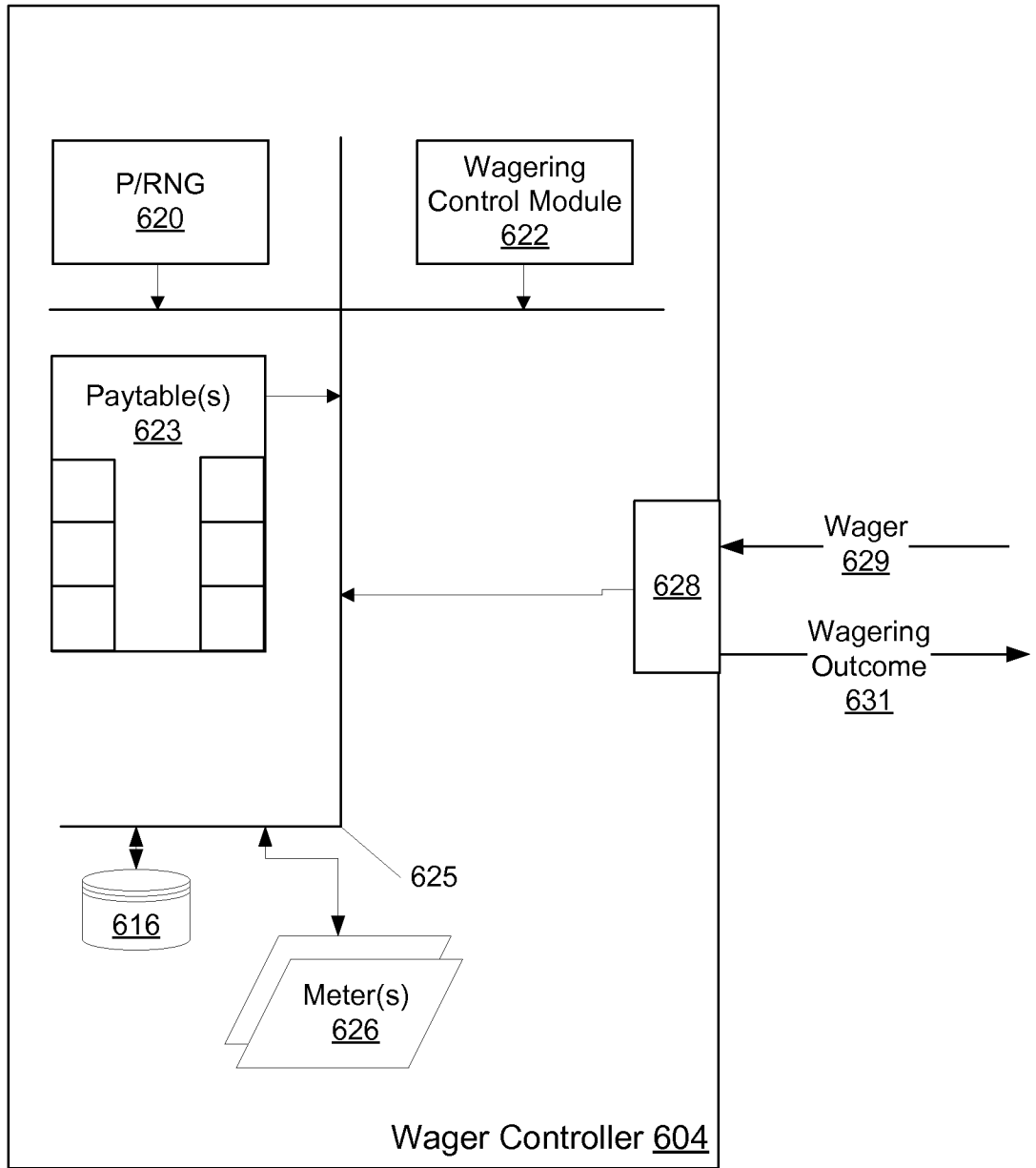

FIG. 5A

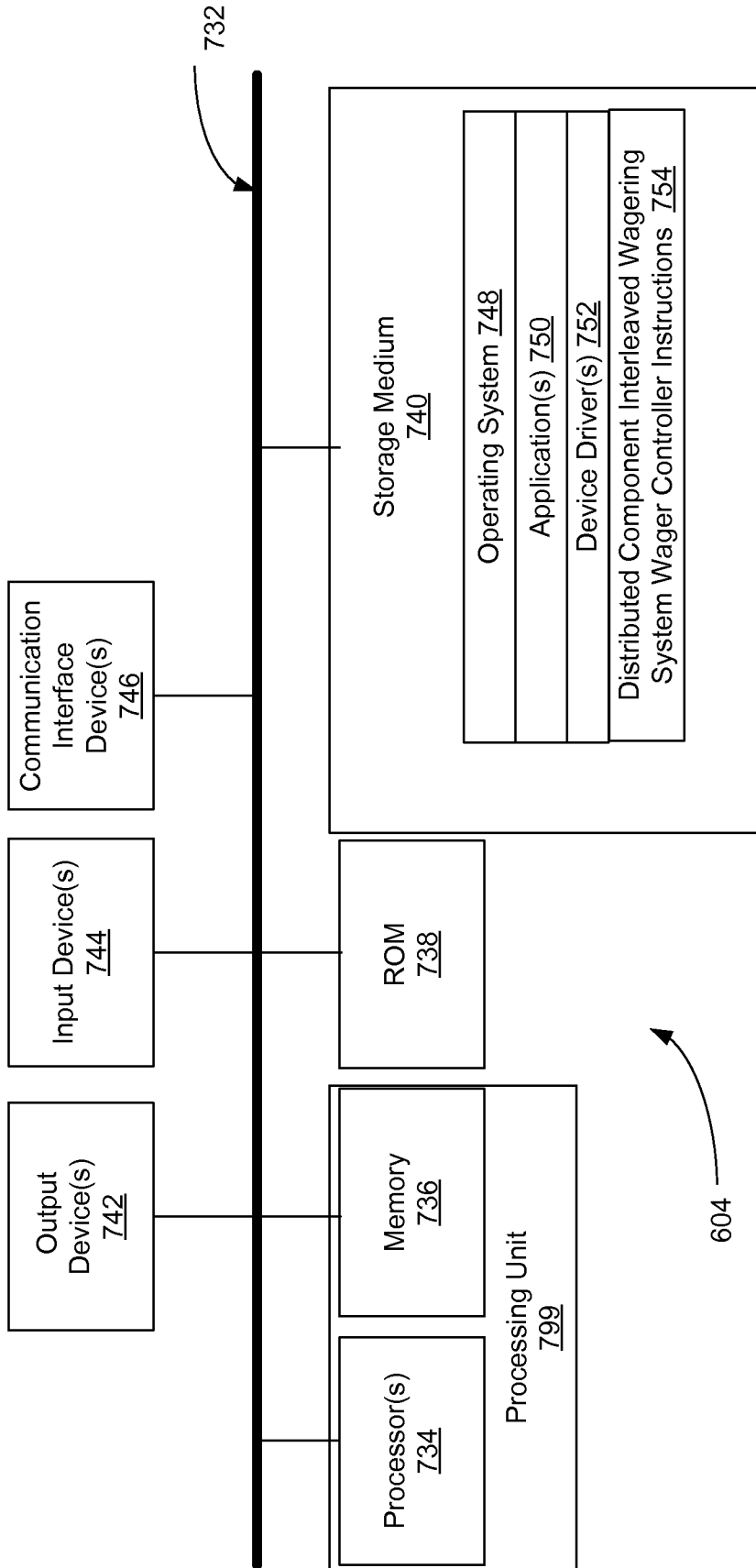

FIG. 5B

9/21

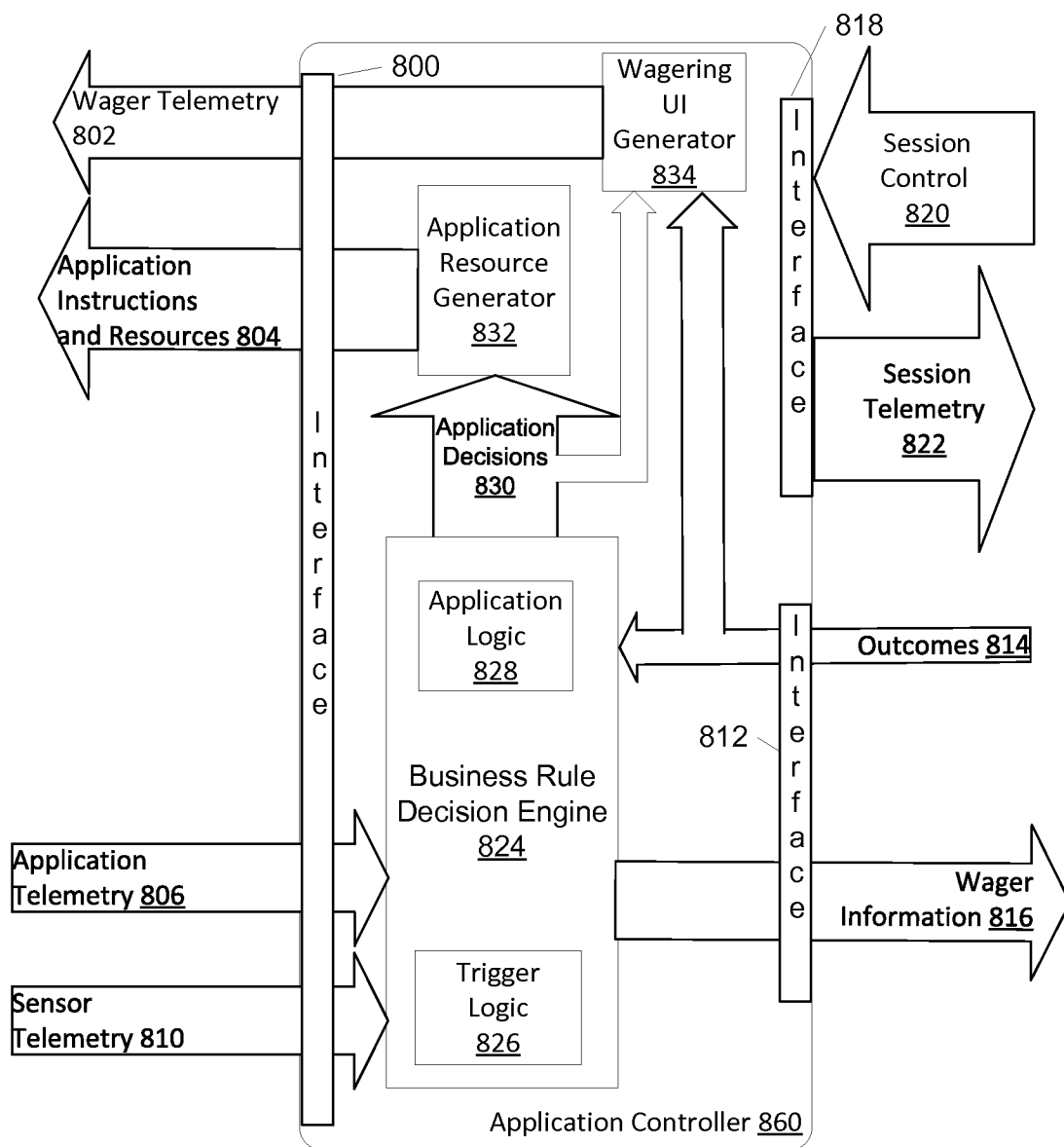

FIG. 6A

10/21

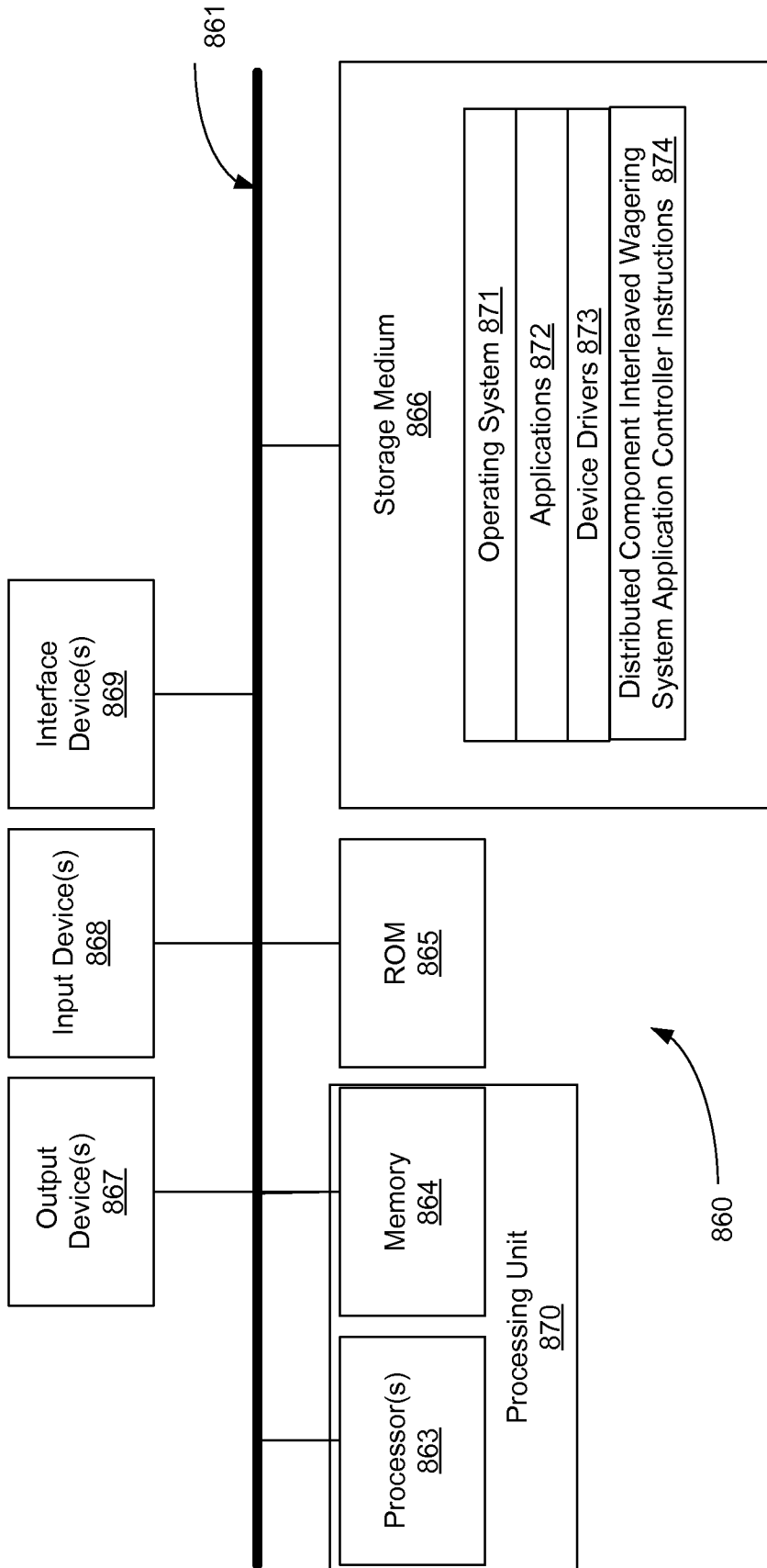

FIG. 6B

11/21

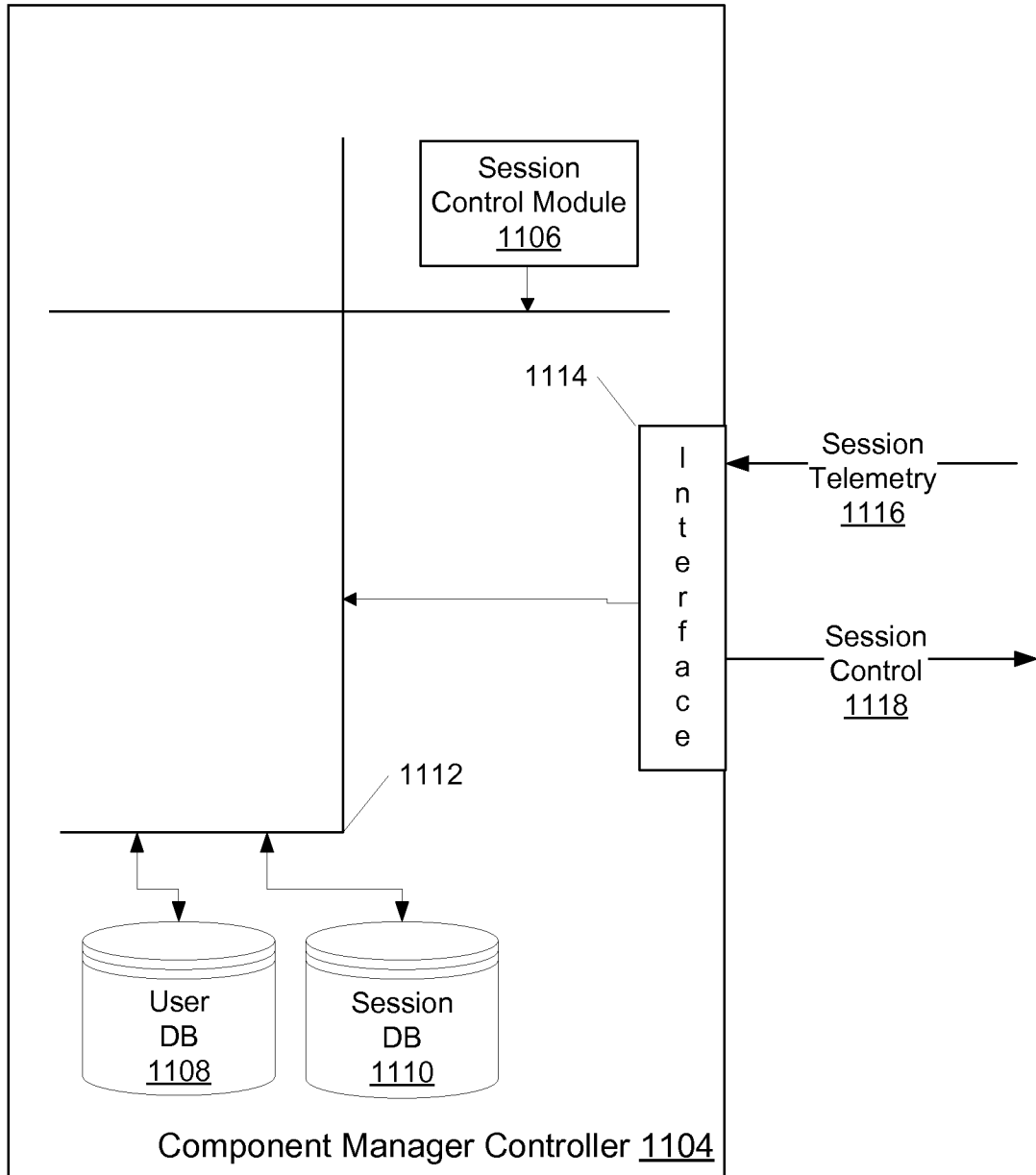

FIG. 7A

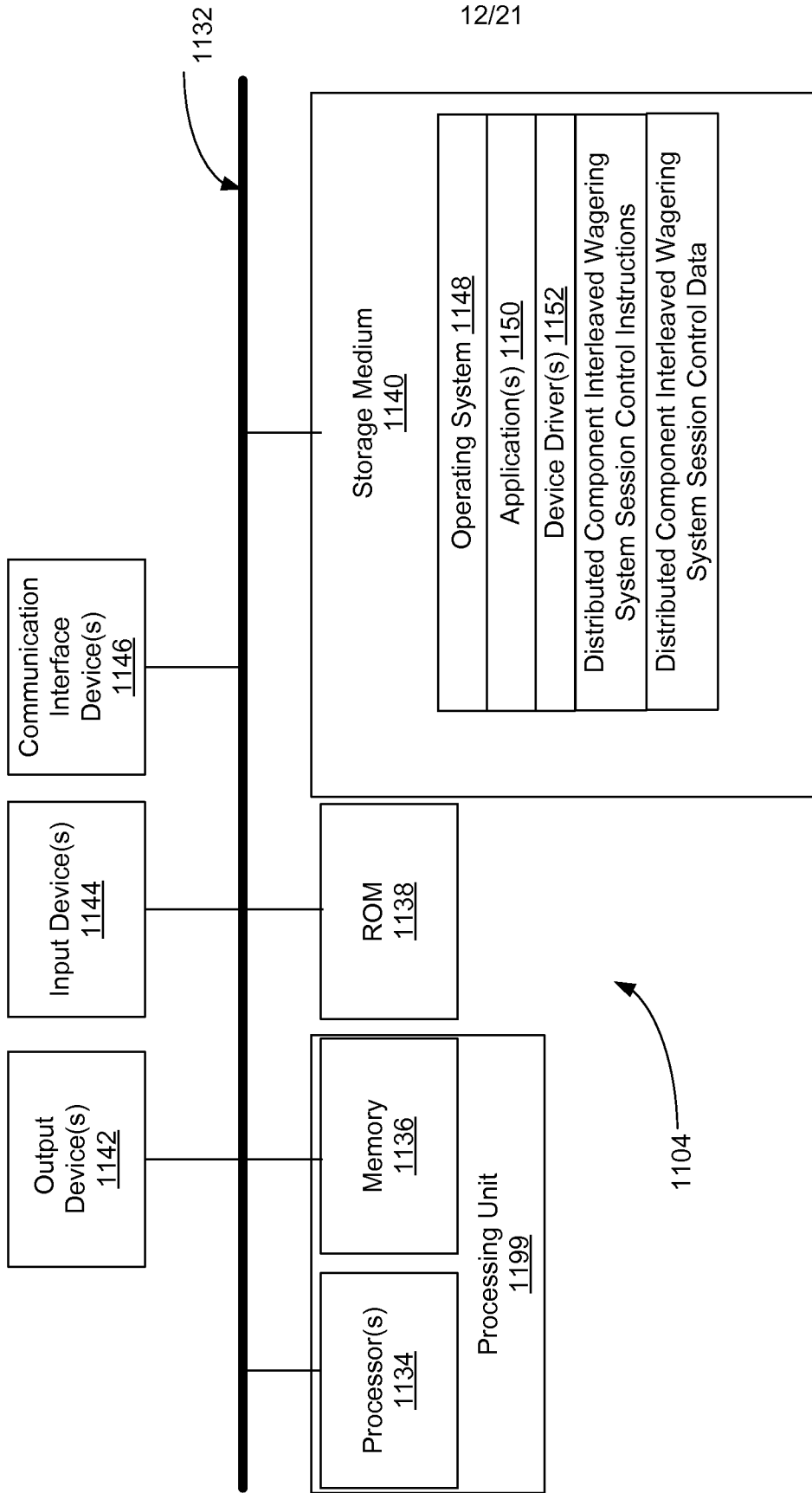

FIG. 7B

13/21

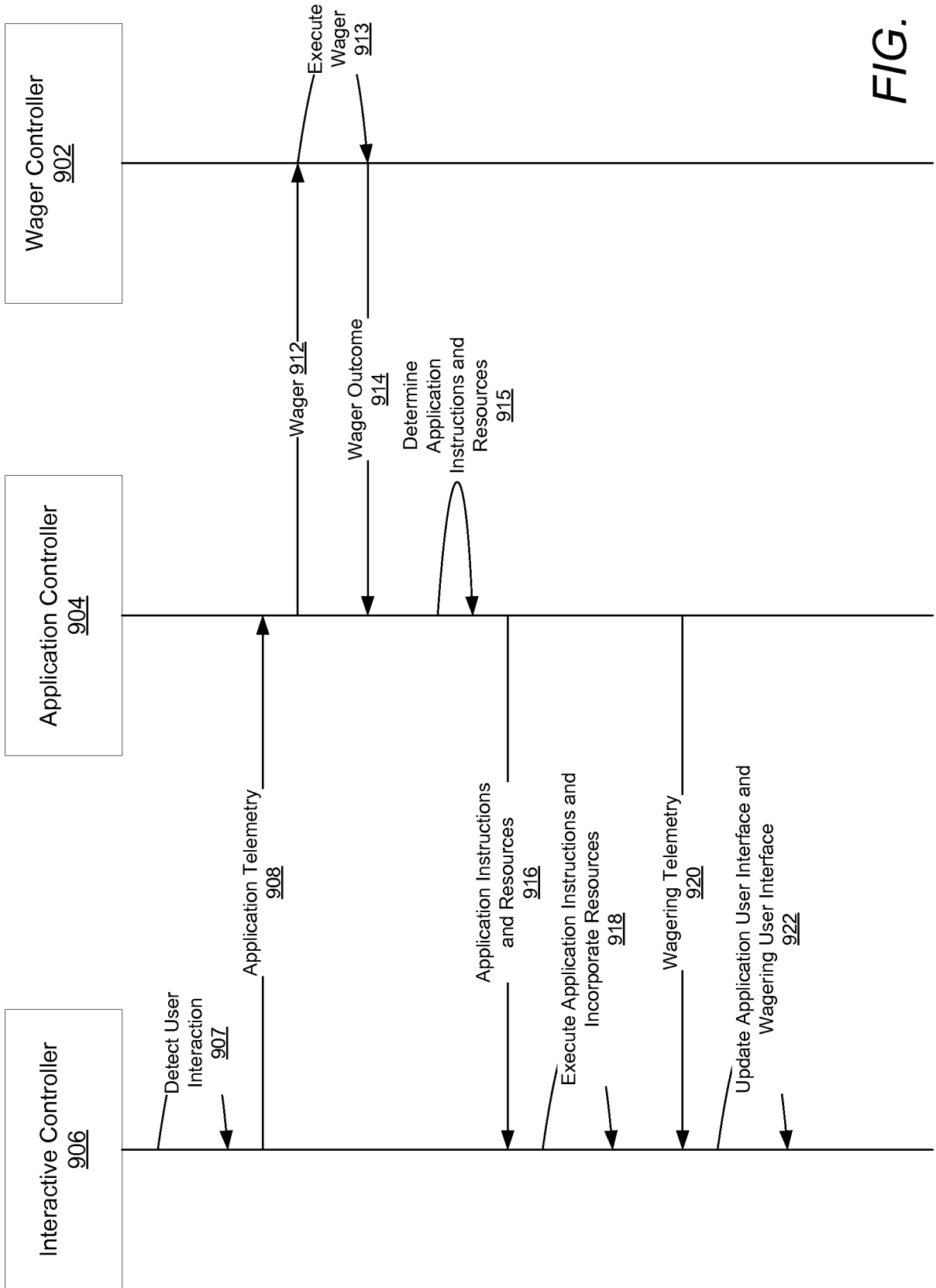

FIG. 8

14/21

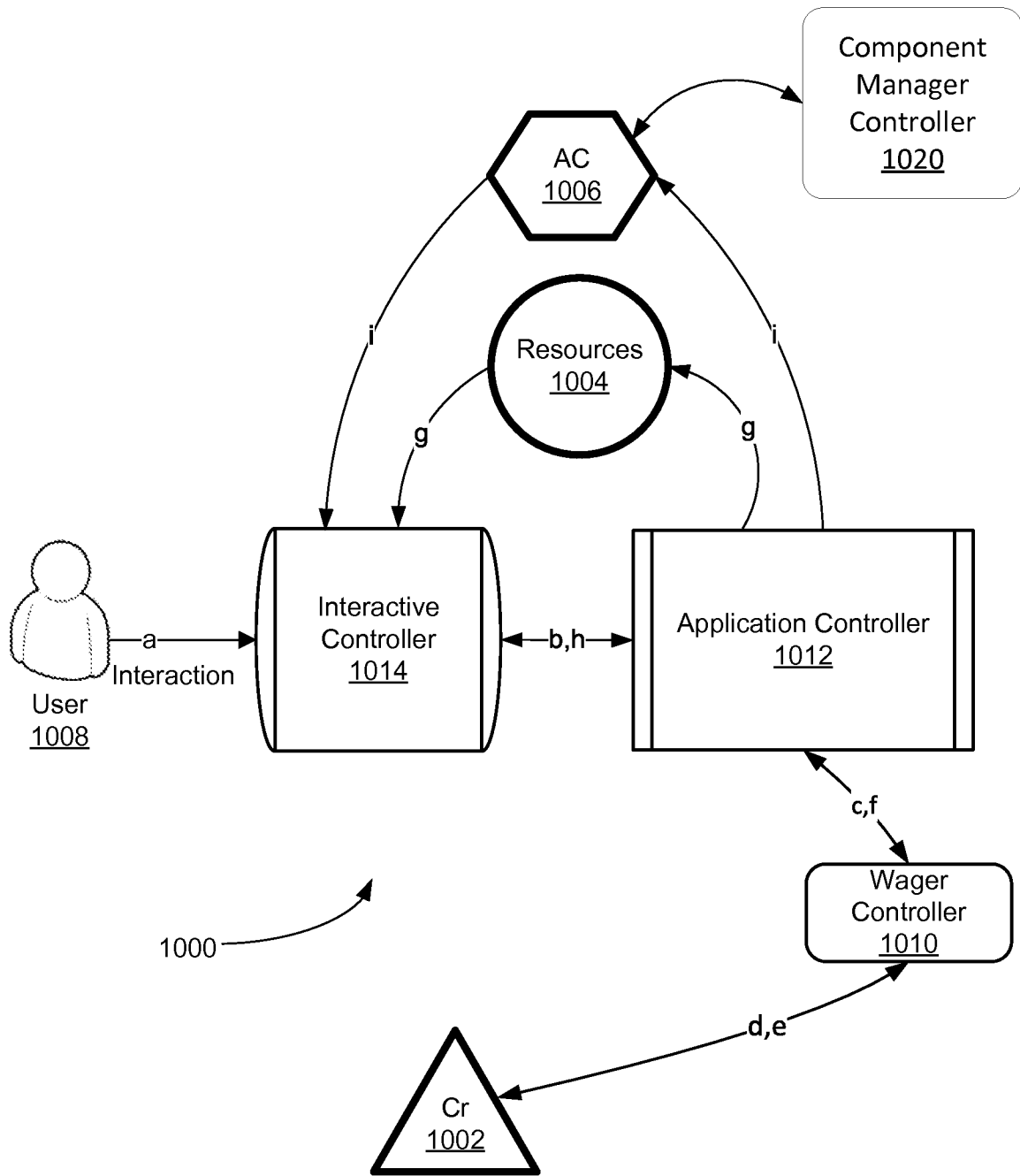

FIG. 9

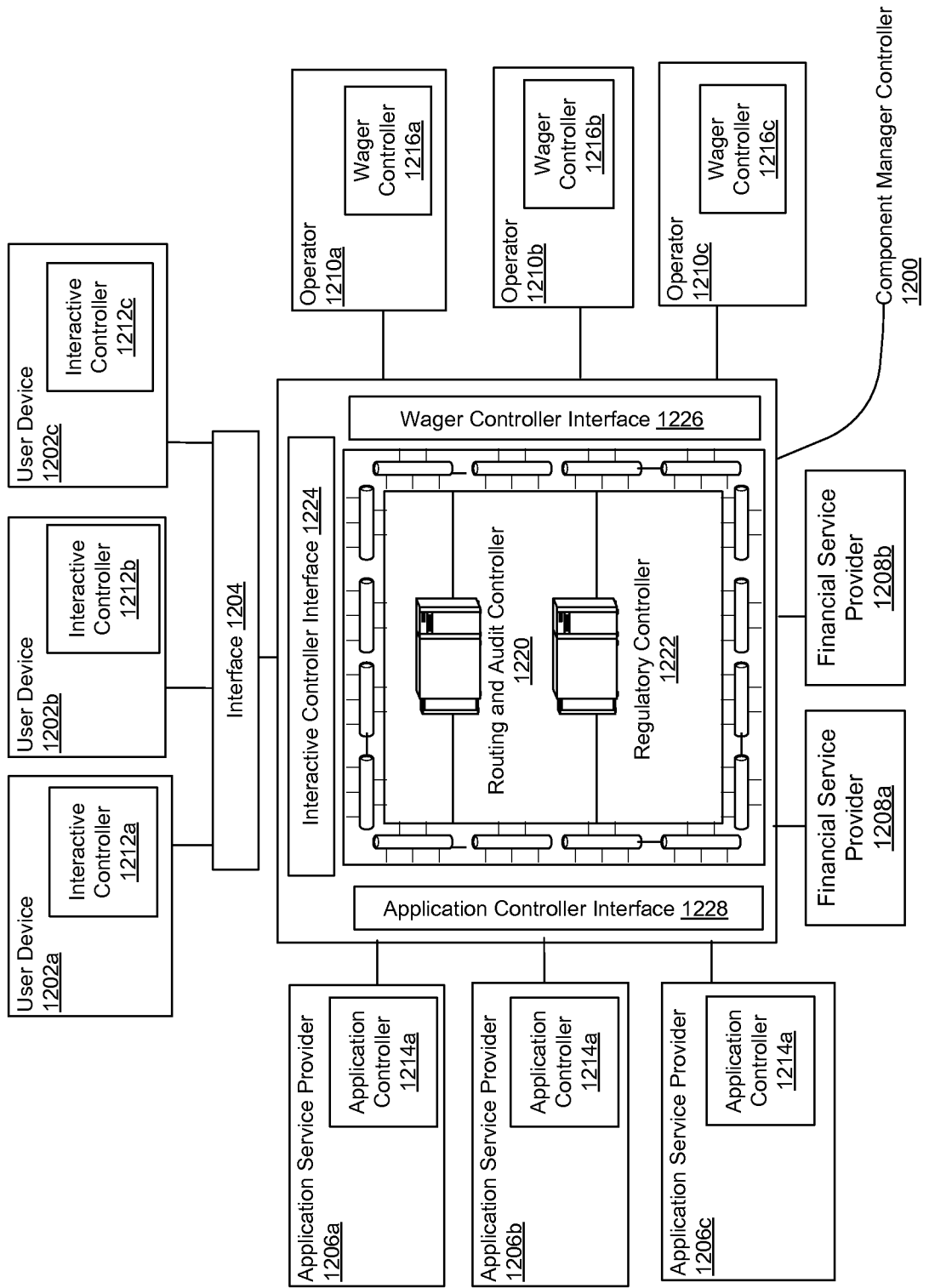

FIG. 10

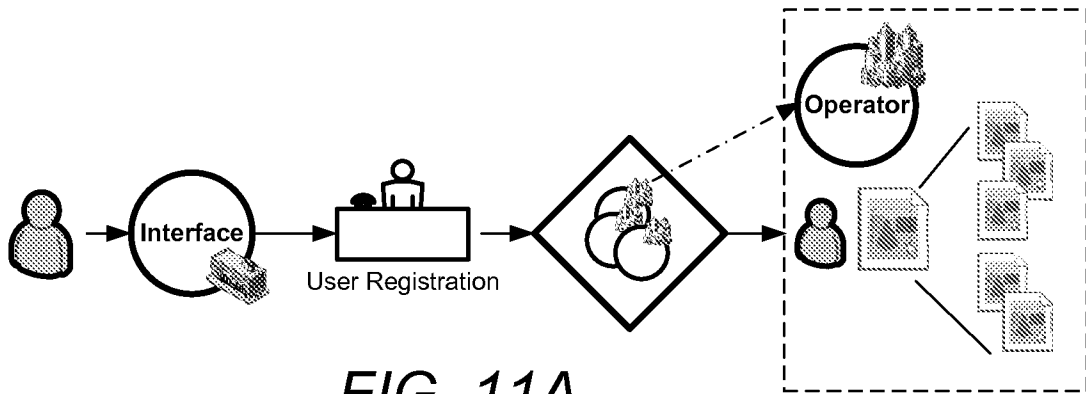

FIG. 11A

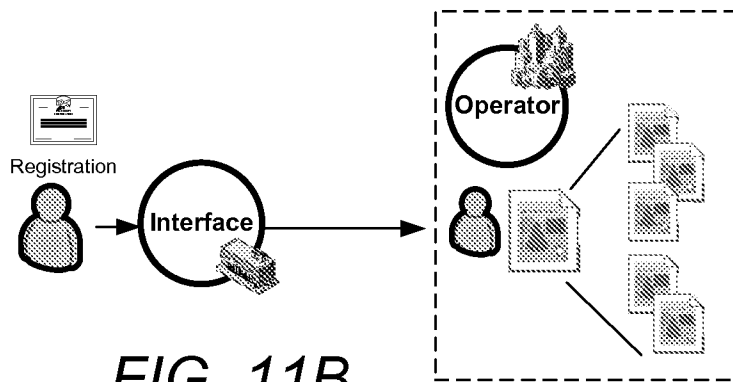

FIG. 11B

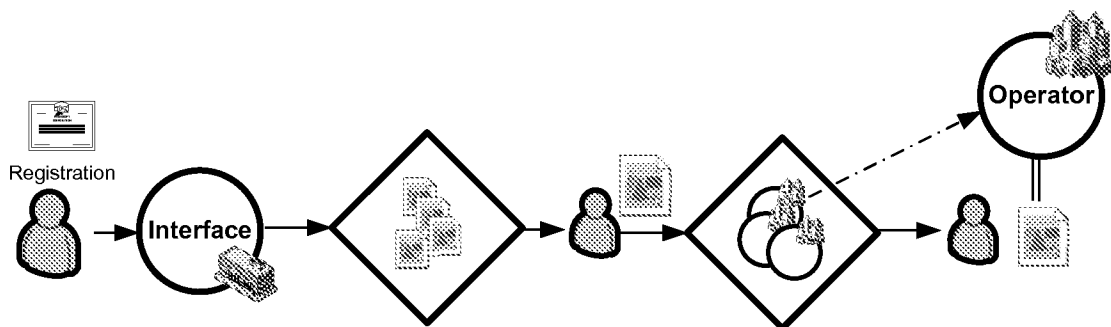

FIG. 11C

17/21

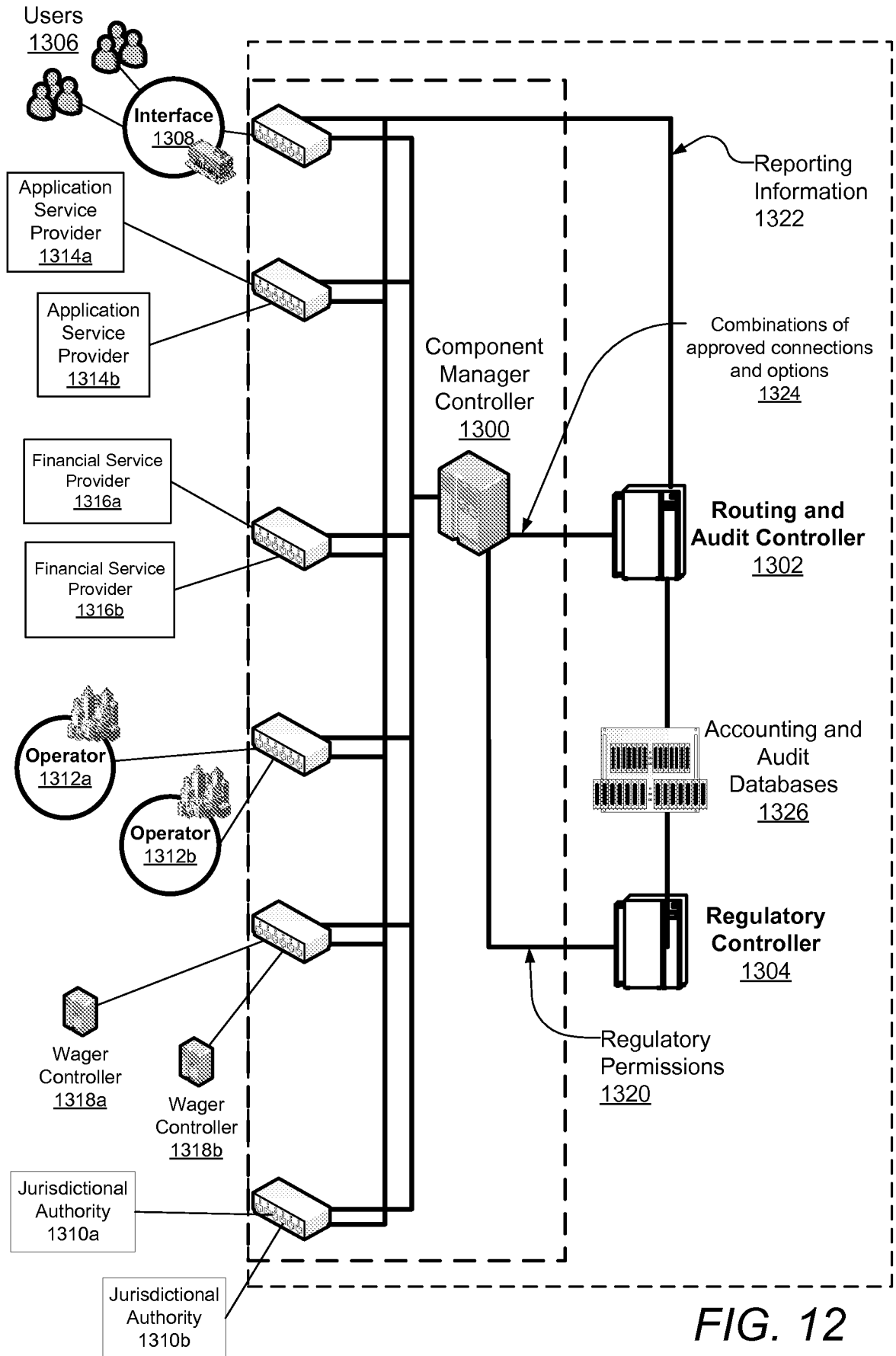

FIG. 12

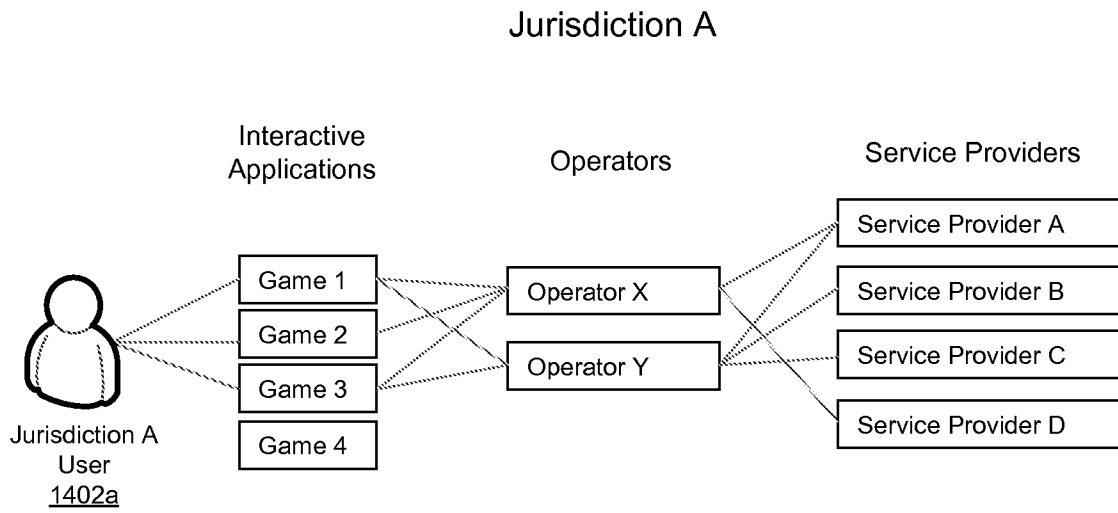

FIG. 13A

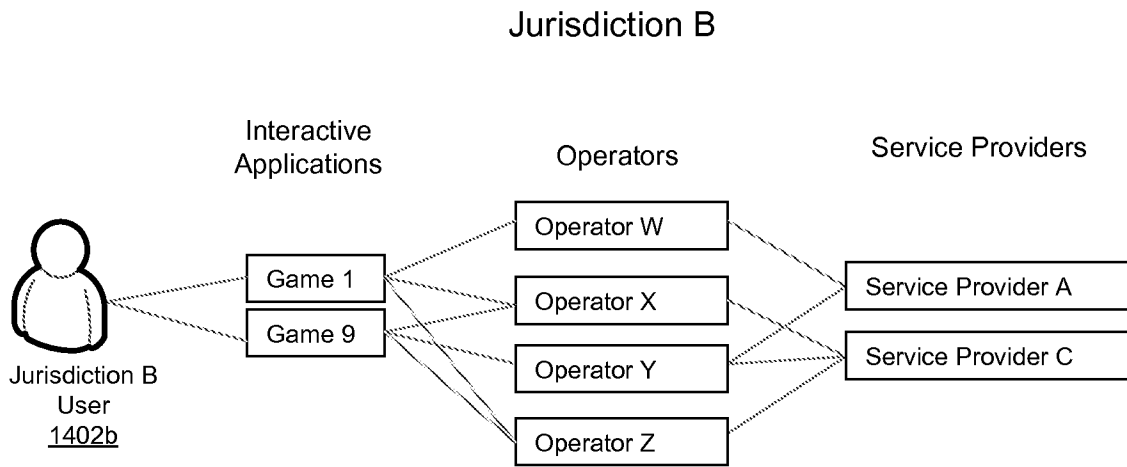

FIG. 13B

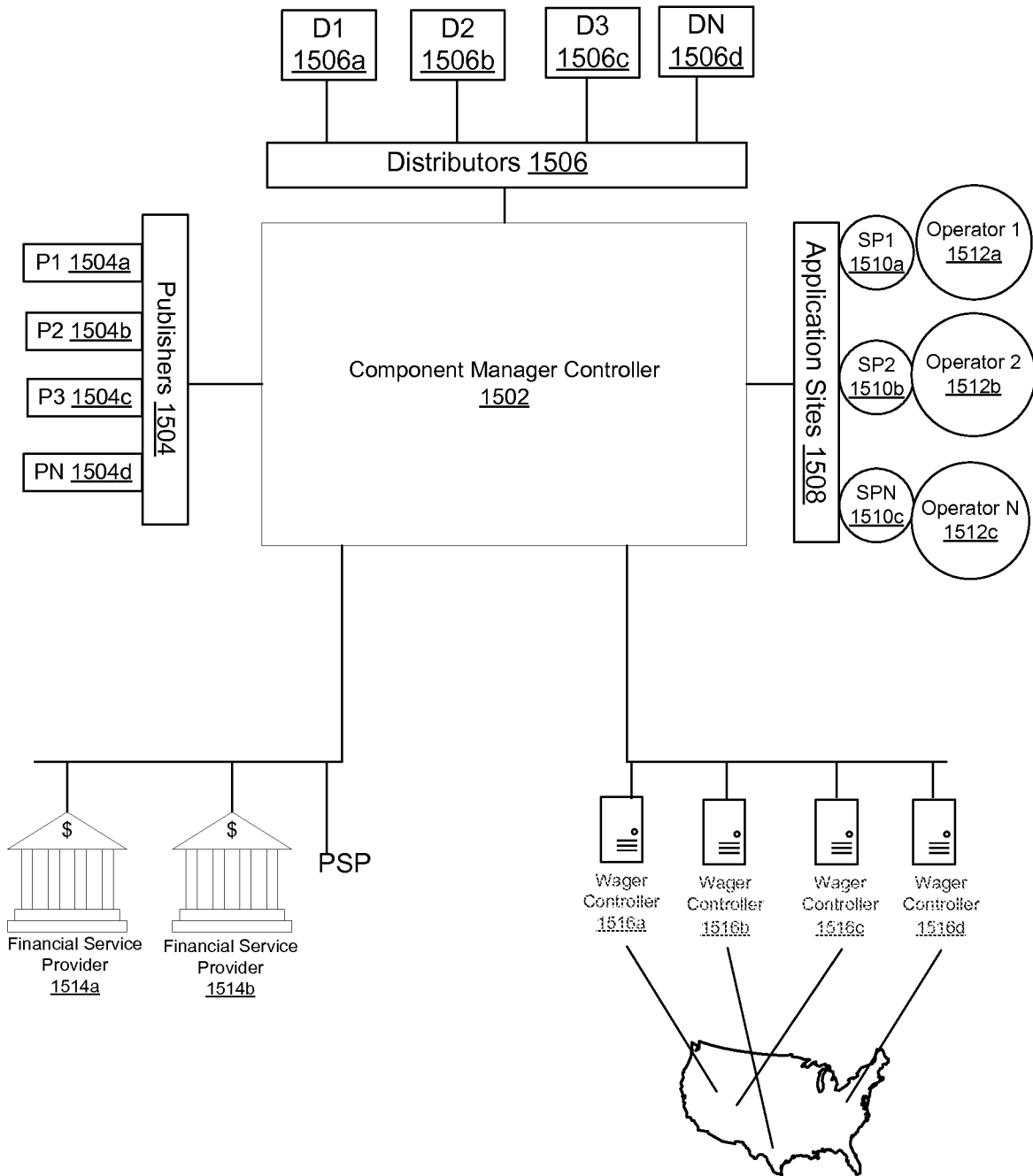

FIG. 14

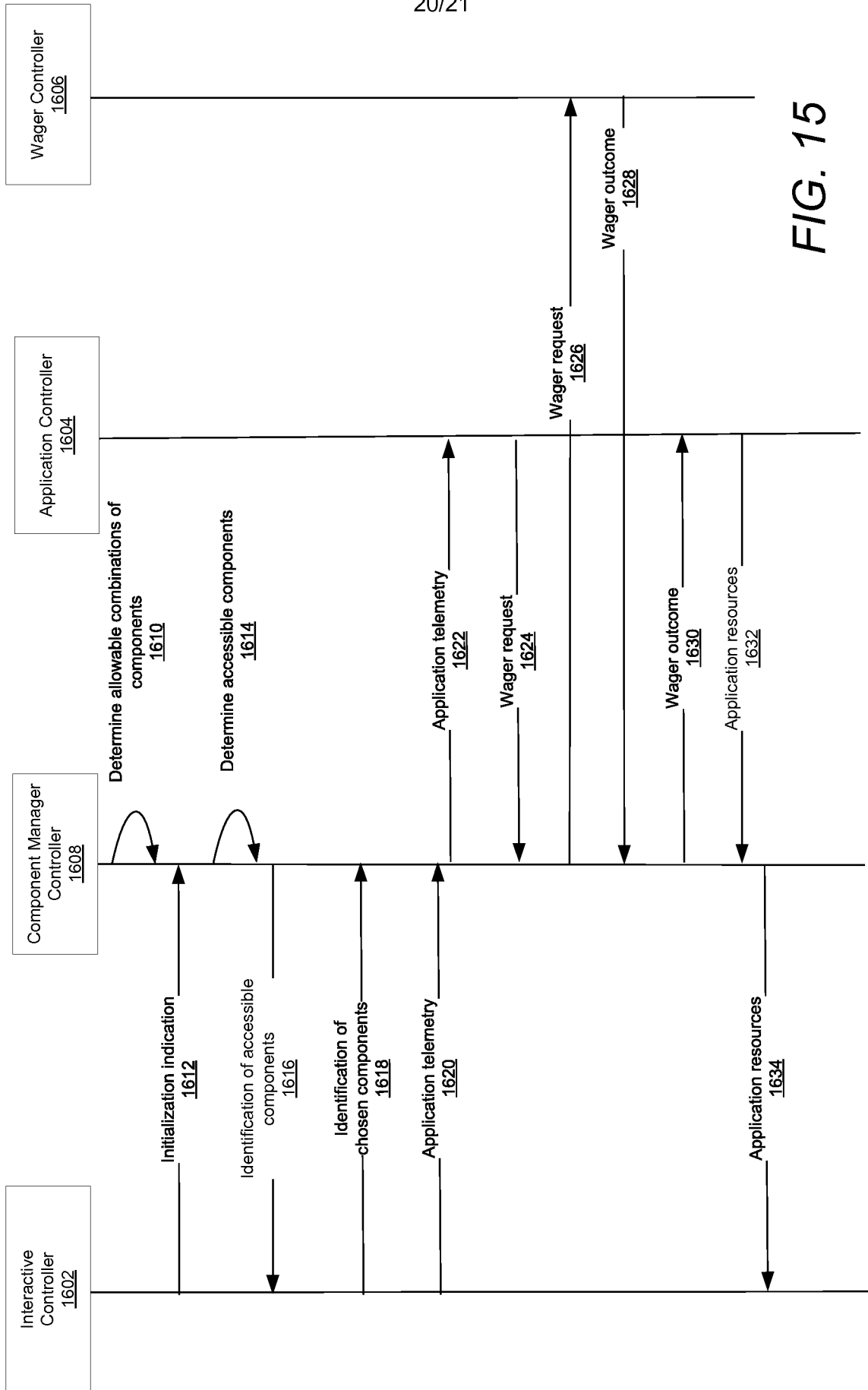

FIG. 15

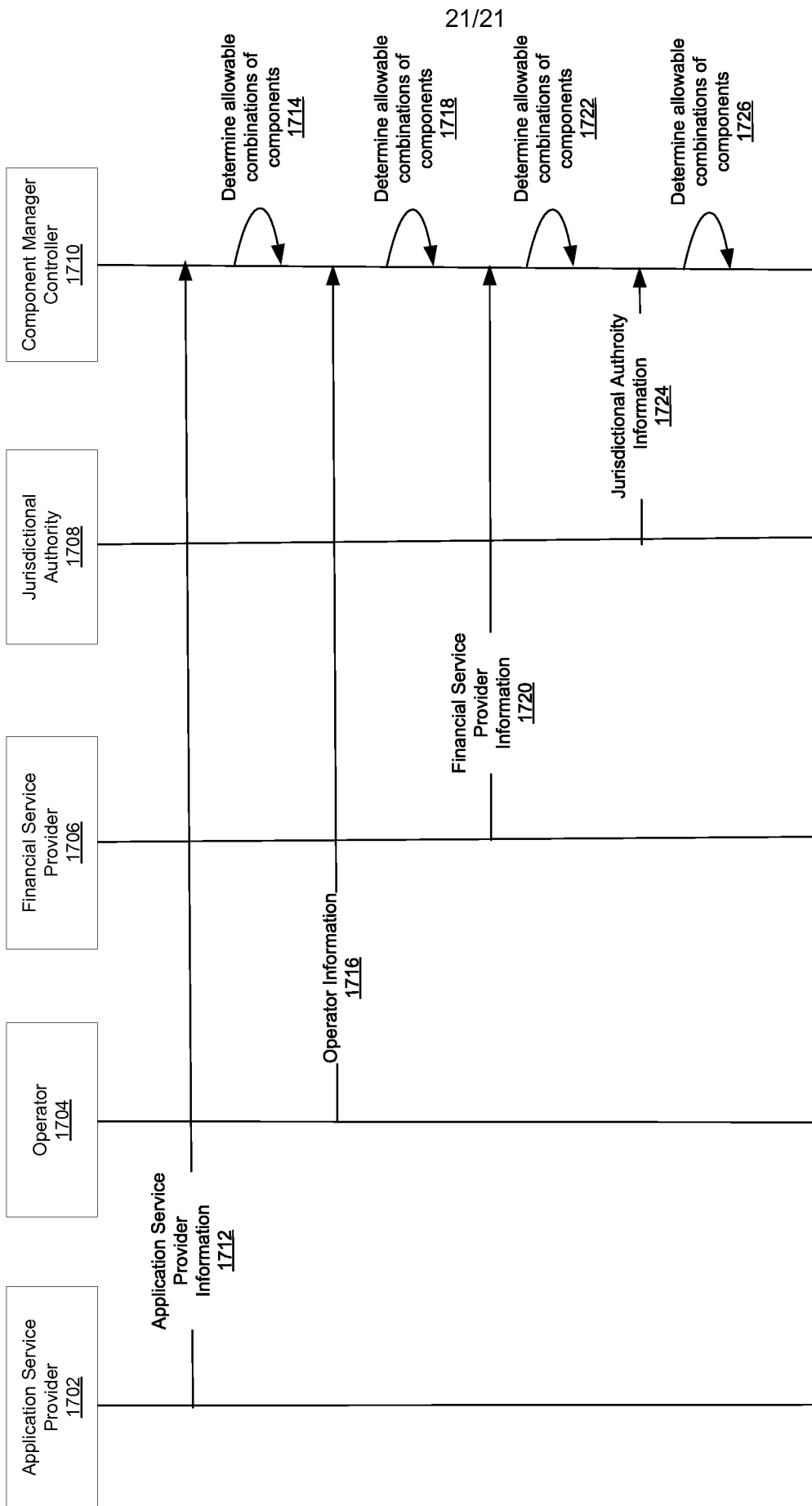

FIG. 16

INTERNATIONAL SEARCH REPORT

International application No.

PCT/US14/65811

A. CLASSIFICATION OF SUBJECT MATTER

IPC(8) - A63F 9/24; G07F 17/32 (2015.01)

CPC - A63F 9/24; G07F 17/32, 17/322

According to International Patent Classification (IPC) or to both national classification and IPC

B. FIELDS SEARCHED

Minimum documentation searched (classification system followed by classification symbols)

IPC(8): A63F 1/12, 1/14, 9/24, 13/00; G06F 19/00; G07F 17/30, 17/32 (2015.01);

CPC: A63F 1/12, 1/14, 9/24; G07F 17/30, 17/32, 17/322, 17/3227, 17/3244, 17/3293; USPC: 273/292; 463/16, 20, 25, 29, 31, 42

Documentation searched other than minimum documentation to the extent that such documents are included in the fields searched

Electronic data base consulted during the international search (name of data base and, where practicable, search terms used)

PatSeer (US, EP, WO, JP, DE, GB, CN, FR, KR, ES, AU, IN, CA, INPADOC); Google/Google Scholar; ProQuest; IP.com; SEARCH TERMS: handheld, device, interactive, game, gaming, controller, management, managing, network, server, wager, betting, gamble, application, outcome, generate, interleave, jurisdiction, authority

C. DOCUMENTS CONSIDERED TO BE RELEVANT

Category*	Citation of document, with indication, where appropriate, of the relevant passages	Relevant to claim No.
X ----- Y	US 2012/0322545 A1 (ARNONE, M., et al.) December 20, 2012; abstract; figures 1 and 4; paragraphs [0041]-[0043], [0066], [0069]-[0071], [0074], and [0075].	1-4, 6-9, 11 ----- 5, 10
Y.	US 2013/0143649 A1 (WMS GAMING, INC.) June 6, 2013; figure 1; paragraphs [0020] and [0038].	5, 10
A	US 2012/0220353 A1 (MASSING, S., et al.) August 30, 2012; entire document.	1-11
A	US 2011/0218038 A1 (KINSLEY, M., et al.) September 8, 2011; entire document.	1-11

Further documents are listed in the continuation of Box C.

* Special categories of cited documents:

"A" document defining the general state of the art which is not considered to be of particular relevance

"E" earlier application or patent but published on or after the international filing date

"L" document which may throw doubts on priority claim(s) or which is cited to establish the publication date of another citation or other special reason (as specified)

"O" document referring to an oral disclosure, use, exhibition or other means

"P" document published prior to the international filing date but later than the priority date claimed

"T" later document published after the international filing date or priority date and not in conflict with the application but cited to understand the principle or theory underlying the invention

"X" document of particular relevance; the claimed invention cannot be considered novel or cannot be considered to involve an inventive step when the document is taken alone

"Y" document of particular relevance; the claimed invention cannot be considered to involve an inventive step when the document is combined with one or more other such documents, such combination being obvious to a person skilled in the art

"&" document member of the same patent family

Date of the actual completion of the international search

30 January 2015 (30.01.2015)

Date of mailing of the international search report

11 FEB 2015

Name and mailing address of the ISA/US

Mail Stop PCT, Attn: ISA/US, Commissioner for Patents
P.O. Box 1450, Alexandria, Virginia 22313-1450
Facsimile No. 571-273-3201

Authorized officer:

Shane Thomas

PCT Helpdesk: 571-272-4300
PCT OSP: 571-272-7774