

(No Model.)

D. J. CARTWRIGHT.  
ROSETTE FOR ELECTRIC LIGHT WIRES.

No. 525,315.

Patented Aug. 28, 1894.

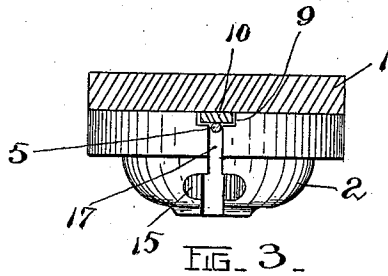
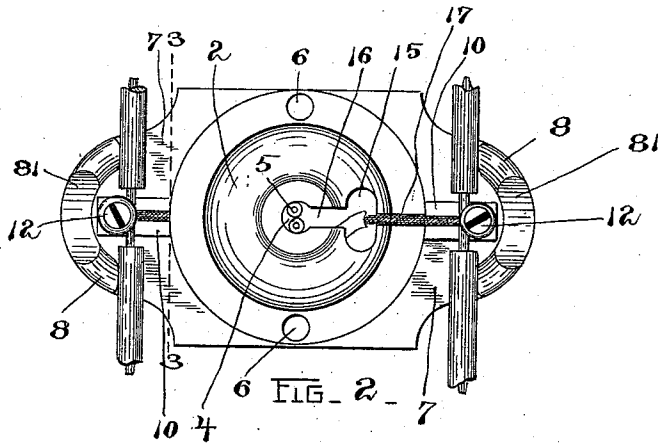
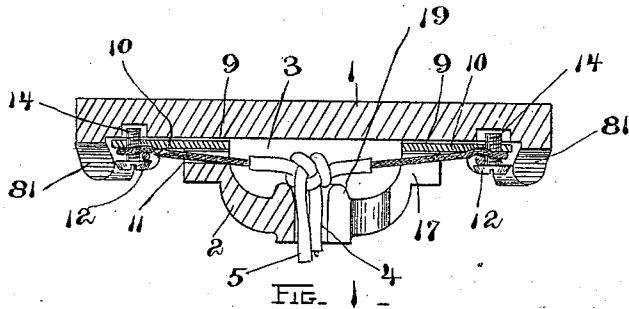

Witnesses.

Harry M. Keys  
Arthur F. Randall

Inventor.

David J. Cartwright  
by Mackay Calver & Randall  
his Attorneys

# UNITED STATES PATENT OFFICE.

DAVID J. CARTWRIGHT, OF BOSTON, MASSACHUSETTS.

## ROSETTE FOR ELECTRIC-LIGHT WIRES.

SPECIFICATION forming part of Letters Patent No. 525,315, dated August 28, 1894.

Application filed January 16, 1894. Serial No. 497,016. (No model.)

*To all whom it may concern:*

Be it known that I, DAVID J. CARTWRIGHT, a citizen of the United States, residing at Boston, in the county of Suffolk and State of Massachusetts, have invented certain new and useful Improvements in Rosettes for Electric-Light Wires, of which the following is a specification, reference being had therein to the accompanying drawings.

My invention is designed as an improvement on that invention which is presented in the application of Charles N. Hammond, for patent for improvements in rosettes for electric light wires, filed January 15, 1894, Serial No. 496,876. In the use of rosettes of the character of those to which the said invention relates, the strands of the lamp-cord, after being passed together through the central hole which is provided for that purpose, are tied or knotted together to form the knot which prevents the ends of said strands from withdrawing from the rosette. This requires in the case of most rosettes that the knot be tied while the rosettes are disconnected from their supports. In the case of the rosette of the said application while the construction is such to enable the knot to be tied after the rosette is secured to its support, the two ends of the lamp cord are drawn out through one of the side openings provided in the bulb or boss, for the purpose of being tied, being afterward retracted into the interior of the rosette.

The objects of my invention are to provide an improved construction of rosette which shall facilitate the application of the lamp-cord to the rosette, as well as enable the knotting together of the strands of the said lamp-cord to be effected before the same is applied to the rosette; and also to improve the interior construction of the bulb or boss.

The invention consists in certain novel features of construction which first will be fully described with reference to the accompanying drawings, and then will be particularly pointed out and distinctly defined in the claims at the close of this specification.

Figure 1 is a view in longitudinal section of a rosette of substantially the character of that shown and described in the application aforesaid, but having my invention embodied therein, and showing the lamp-cords and feed-wires applied thereto. Fig. 2 is a view of the

parts which are represented in Fig. 1, it showing them in inverted plan and representing the entire rosette. Fig. 3 is a view in vertical section on the line 3—3 of Fig. 2, looking toward the right hand side in the latter figure.

The rosette shown in the drawings is formed of some suitable non-conducting material. The body thereof comprises a back or base portion 1, and a bulb or boss 2 having an internal chamber 3, the said parts being made integral or solid with each other, and a hole 4 being made centrally through the face of the bulb or boss and opening into the said chamber 3, the said hole serving for the passage of the lamp-cord 5. The back or base portion 1 is made solid or continuous and closes the said chamber 3 on the side of the rosette which is next to the support to which the rosette is applied when in use. Holes 6, 6 are formed through the body at the opposite edges thereof, for the passage of the screws or other fastening devices which are employed to secure the rosette in place upon the ceiling or other support to which it is applied. At opposite sides of the bulb or boss 2 the back or base portion 1 has lateral extensions or ears 7, 7, from the outer edges of which extend at right angles the guard flanges 8, 8. The portion 80 of the bulb or boss 2 which joins the back or base 1 has formed therethrough, on sides thereof which are adjacent to the flanges 8, 8, the horizontal slots 9, 9, for the reception of metal strips 10, 10. The strips 10, 10, fit the slots 9, 9, so as thereby to be held in place in the rosette, although they are capable of endwise movement therethrough, such as enables them to be applied or removed. Communicating with one of the said slots 9, namely that on the left hand side of Fig. 2, is the groove 11 through which is passed the bared end of one of the strands of the lamp cord. The outer end of each strip 10 has a threaded hole therethrough for the reception of the stem of a binder screw 12. At 14, 14 are holes or recesses in the back or base 1 into which the ends of the binder screws project, the said ends fitting loosely in the said holes or recesses, and having free play therein, but being limited in their movement by the ends of such holes or recesses, the removal of the said strips after the screws have been turned in thereby being prevented. In applying the

strips 10, 10, to the body of the rosette when assembling the parts, the said strips are simply slipped endwise in the slots 9, 9, the cut-away places 81 of the flanges 8, 8, permitting the application of the strips in the manner stated. After the strips have been thus slipped into place, the binder screws 12, 12, are applied to the holes in the outer ends thereof, the inner ends of the said screws projecting into the holes or recesses 14, 14 in the back or base portion, and, although they fit and play loosely in said holes or recesses, operating to prevent the withdrawal of the strips. As so far described, the rosette is essentially the same in the features referred to as in the case of the rosette of the application aforesaid.

In carrying out my present invention, I form in the bulb or boss 2, at one side of the central hole 4, a hole 15, which, as viewed in Fig. 2, is nearly elliptical in shape, the greater diameter thereof being extended in a direction crosswise of the rosette. A slot 16 connects this hole or opening 15 with the central hole 4, and a second cross-slot 17 connects the said hole or opening 15 with the adjacent slot 9, this latter feature being most plainly visible in Fig. 3.

In applying the lamp cord to the rosette constructed as aforesaid, the ends of the lamp-cord strands are first knotted together in the usual manner and as indicated in Fig. 1. The projecting free end of one of the strands is then pushed in through the hole 15 and passed out on the opposite side of the bulb or boss 2 through the groove 11 on that side as indicated in Fig. 1. The knotted portion of the strand is then passed in through the hole 15, the knot being turned edgewise so that the greater diameter thereof shall correspond with the greater diameter of the said hole, and the knot is pushed through the said hole into the internal chamber 3, after which the cords below the knot are carried by a lateral movement through the slot 16 into the central hole 4. The projecting end of the remaining lamp-cord strand is then passed down into the slot 17. The ends of the bared strands of the lamp cords then are applied to the stems of the binder screws 12, and after bared portions of the feed wires 15 have been placed under the heads of the binder screws the latter are turned in so as to clamp the lamp cord strands and feed wires together and against the strips 10. In order to provide an improved seat on which the knot may take bearing and remain while the ends of

the said strands are being secured by the binders, thereby obviating the liability of the said knot becoming accidentally shifted laterally and withdrawing through the hole 15, as well as guard against the insulation of the lamp cord being destroyed by coming in contact with a sharp edge at the inner end of the hole 4, I form the bulb or boss on its interior with a rounded raised ring 19 as shown in Fig. 1, or its equivalent, around the inner end of the central hole 4, and also slightly enlarge the inner end of the said hole for the reception of the knot. The strain on the lamp-cord from below holds the knot in the seat thus provided therefor, and the rounded surface is free from liability to cut the insulation.

I claim as my invention—

1. A rosette having an internal chamber, a central hole through which the lamp-cord passes to the said internal chamber, side-slots as described, the hole 15, the slots 16 and 17 leading from hole 15 to the central hole and one of the side-slots, respectively, for use in applying the lamp cord, and binders, substantially as described.

2. A rosette having an internal chamber and a back or base extending continuously across and closing the said chamber, a central hole in the bulb or boss thereof through which the lamp cord passes to the said internal chamber, side-slots, the hole or opening 15, the slots 16 and 17 leading from hole 15 to the central hole and one of the side-slots respectively, for use in applying the lamp-cord, and binders, substantially as described.

3. A rosette having an internal chamber, the central hole 4 through which the lamp-cord passes to the said internal chamber, the hole or opening 15, the slot 16 connecting holes 4 and 15, and the rounded raised ring surrounding the inner end of the hole 4, substantially as described.

4. A rosette having an internal chamber, the central hole 4 through which the lamp-cord passes to the said internal chamber, the hole or opening 15, the slot 16 connecting holes 4 and 15, the inner end of the hole or opening 4 being slightly enlarged, and the raised ring at the inner end of said hole, substantially as described.

In testimony whereof I affix my signature in presence of two witnesses.

DAVID J. CARTWRIGHT.

Witnesses:

WM. A. MACLEOD,  
CHAS. F. RANDALL.