

(19) World Intellectual Property Organization  
International Bureau



(43) International Publication Date  
19 February 2009 (19.02.2009)

PCT

(10) International Publication Number  
**WO 2009/023221 A1**

(51) International Patent Classification:  
A61F 2/84 (2006.01)

(74) Agent: GODLEWSKI, Richard, J.; P.o. Box 2269,  
Bloomington, IN 47402-2269 (US).

(21) International Application Number:  
PCT/US2008/009685

(81) Designated States (unless otherwise indicated, for every kind of national protection available): AE, AG, AL, AM, AO, AT, AU, AZ, BA, BB, BG, BH, BR, BW, BY, BZ, CA, CH, CN, CO, CR, CU, CZ, DE, DK, DM, DO, DZ, EC, EE, EG, ES, FI, GB, GD, GE, GH, GM, GT, HN, HR, HU, ID, IL, IN, IS, JP, KE, KG, KM, KN, KP, KR, KZ, LA, LC, LK, LR, LS, LT, LU, LY, MA, MD, ME, MG, MK, MN, MW, MX, MY, MZ, NA, NG, NI, NO, NZ, OM, PG, PH, PL, PT, RO, RS, RU, SC, SD, SE, SG, SK, SL, SM, ST, SV, SY, TJ, TM, TN, TR, TT, TZ, UA, UG, US, UZ, VC, VN, ZA, ZM, ZW.

(22) International Filing Date: 13 August 2008 (13.08.2008)

(25) Filing Language: English

(26) Publication Language: English

(30) Priority Data:  
60/964,456 13 August 2007 (13.08.2007) US

(71) Applicants (for all designated States except US):  
**WILLIAM A. COOK AUSTRALIA PTY. LTD.** [AU/AU]; 12 Electronics Street, Brisbane Technology Park, Eight Mile Plains, Brisbane, Queensland, 4113 (AU).  
**COOK INCORPORATED** [US/US]; 750 N. Daniels Way, Bloomington, IN 47404 (US).

(84) Designated States (unless otherwise indicated, for every kind of regional protection available): ARIPO (BW, GH, GM, KE, LS, MW, MZ, NA, SD, SL, SZ, TZ, UG, ZM, ZW), Eurasian (AM, AZ, BY, KG, KZ, MD, RU, TJ, TM), European (AT, BE, BG, CH, CY, CZ, DE, DK, EE, ES, FI, FR, GB, GR, HR, HU, IE, IS, IT, LT, LU, LV, MC, MT, NL, NO, PL, PT, RO, SE, SI, SK, TR), OAPI (BF, BJ, CF, CG, CI, CM, GA, GN, GQ, GW, ML, MR, NE, SN, TD, TG).

(72) Inventors; and

(75) Inventors/Applicants (for US only): **HARTLEY, David, Ernest** [AU/AU]; 73 Sandpiper Island Retreat, Wannanup, Western, 6210 (AU). **DUCKE, Werner, Dieter** [AU/AU]; 4 Mattison Way, Greenwood, Western Australia, 6024 (AU).

Published:  
— with international search report

(54) Title: DEPLOYMENT DEVICE

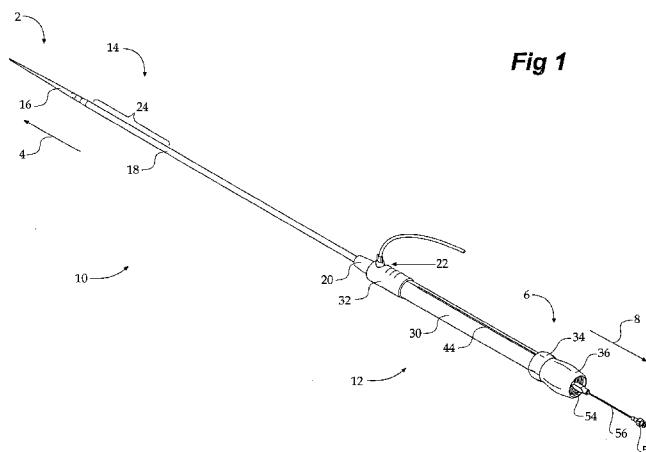

Fig 1

(57) Abstract: A stent graft deployment device (10) has a tubular fixed handle (34, 36) to be gripped and held by a user and an elongate release handle (30) extending through the fixed handle so that the release handle can be moved through the fixed handle. The deployment device assembly has a pusher (38) and a sheath (18) to cover a stent graft (64) on the pusher. The pusher is connected to the fixed handle and the sheath is connected to the release handle so that retraction of the release handle through the fixed handle causes the sheath to be retracted from the stent graft on the pusher. The fixed handle includes a grip component (34) that grips the pusher and a rotator component (36) that grips a release clamp (48) on the pusher. The release clamp has trigger wires for the release of the stent graft attached to it. The rotator component has a screw thread (54) with a portion (52) of the release clamp engaged into the screw thread so that rotation of the rotator component causes longitudinal movement of the release clamp on the pusher which pulls the trigger wires.



WO 2009/023221 A1

- 1 -

## DEPLOYMENT DEVICE

DescriptionTechnical Field

5 This invention relates to a deployment device, and more particularly to a device for controlled endovascular deployment of a stent graft.

Background of the Invention

10 In PCT Patent Publication No. WO 98/53761 entitled "A Prosthesis and a Method Deploying a Prosthesis" to the present applicant there is disclosed an introducer for a stent graft which retains the stent graft so that each end can be moved and released independently during the process of endovascular deployment of the stent graft. This device requires that a number of actions be taken in a particular consecutive order to place a stent graft in the required position in the vasculature. One end of the stent graft is released and then another end, and if required, between the release of each of the ends,  
15 a branch stent graft is placed into a side arm of the stent graft. These features and other features disclosed in PCT Patent Publication No. WO 98/53761 are incorporated herein by reference in their entirety into this specification.

It is desirable that the set of sequential actions necessary to release the stent graft at the desired position in the vasculature be undertaken in the required order and  
20 that there be less chance for operator error during such a deployment.

Summary of the Invention

It is the object of this invention therefore to provide a deployment device which is arranged to introduce, deploy and release a stent graft by a series of sequential actions.

25 According to a first aspect of the present invention, there is provided a stent graft deployment device including a handle, the handle including a first part to be gripped and held by a user and a second part to be moved relative to the first part; a pusher on which a stent graft may be mounted; and a sheath to cover a stent graft on the pusher; wherein the pusher is connected to the first part of the handle and the sheath is  
30 connected to the second part of the handle, whereby retraction of the first part of the handle with respect to the second part of the handle causes the sheath to be retracted from a stent graft on the pusher.

- 2 -

According to a first aspect of the present invention, there is provided a stent graft deployment device including a handle, the handle including a first part to be gripped and held by a user and a second part to be moved relative to the first part; a pusher on which a stent graft may be mounted; and a sheath to cover a stent graft on the pusher; wherein the pusher is connected to the first part of the handle and the sheath is connected to the second part of the handle, whereby retraction of the first part of the handle with respect to the second part of the handle causes the sheath to be retracted from a stent graft on the pusher.

Preferably the first part includes a first component which grips the pusher and a second component which grips a release clamp on the pusher, the release clamp on the pusher having trigger wires for the release of the stent graft from the pusher assembly attached thereto, whereby movement of the second component with respect to the first moves the release clamp on the pusher and thereby pulls the trigger wires.

Preferably the second component rotates with respect to the first component and the second component includes a screw thread with a portion of the release clamp engaged into the screw thread whereby rotational movement of the second part causes longitudinal movement of the release clamp on the pusher.

The device can further include a stop on the first part, the stop arranged to engage the release clamp on the pusher assembly after a selected amount of movement of the first part has occurred whereby to prevent further retraction of the sheath from the stent graft until the release clamp has been moved by rotation of the second component on the second part.

The first part can include a bayonet socket for a hub of the sheath.

Preferably the second part is substantially cylindrical and the first part is tubular and slides within the second part.

Preferably the tubular first part has longitudinal slots and an internal lumen and the pusher extends within the longitudinal lumen and the pusher includes arms which extend through the longitudinal slots to engage with the second part whereby the first part can be moved with respect to the second part.

The device can further include a first stop to prevent the first part from moving through the second part in a reverse direction.

The device can further include a detent arrangement acting between the first component and the second component to allow rotation of the second component only in a selected direction.

5 According to a second aspect of the present invention, there is provided a stent graft deployment device, the device including a tubular fixed handle to be gripped and held by a user and an elongate release handle extending through the fixed handle whereby the release handle can be moved through the fixed handle, the deployment device further including a pusher and a sheath to cover a stent graft on the pusher, the pusher being connected to the fixed handle and the sheath being connected to the  
10 release handle whereby retraction of the release handle through the fixed handle causes the sheath to be retracted from the stent graft on the pusher.

According to a third aspect of the present invention, there is provided a stent graft deployment device including: a handle, the handle including a tubular fixed handle to be gripped and held by a user and an elongate release handle extending through the  
15 fixed handle whereby the release handle can be moved through the fixed handle; a pusher and a sheath to cover a stent graft on the pusher, the pusher being connected to the fixed handle and the sheath being connected to the release handle, whereby retraction of the release handle through the fixed handle causes the sheath to be retracted from a stent graft on the pusher; the fixed handle including a grip component  
20 that grips the pusher and a rotator component that grips a release clamp on the pusher; the release clamp on the pusher having a trigger wire for the release of a stent graft from the pusher, attached thereto; and the rotator component including a screw thread with a portion of the release clamp engaged into the screw thread, whereby rotational movement of the rotator component causes longitudinal movement of the release clamp on the  
25 pusher thereby to pull the trigger wires.

According to a fourth aspect of the present invention, there is provided an assembly of a stent graft deployment device as described above and a stent graft mounted on the pusher.

According to a fifth aspect of the present invention, there is provided an  
30 assembly of a handle, a stent graft deployment device and a stent graft, the handle including a first part to be gripped and held by a user and a second part to be moved relative to the first part, the deployment device including a pusher assembly, the stent

graft being mounted onto the pusher assembly and a sheath to cover the stent graft on the pusher assembly, the pusher assembly being connected to the first part and the sheath being connected to the second part whereby retraction of the first part with respect to the second part causes the sheath to be retracted from the stent graft on  
5 the pusher assembly.

According to a fifth aspect of the present invention, there is provided a deployment assembly comprising a handle, a stent graft deployment device and stent graft, the handle including a tubular fixed handle to be gripped and held by a user and an elongate release handle extending through the fixed handle whereby the release  
10 handle can be moved through the fixed handle, the stent graft deployment device including a pusher assembly and a sheath to cover the stent graft on the pusher assembly, the pusher assembly being connected to the fixed handle and the sheath being connected to the release handle whereby retraction of the release handle through the fixed handle causes the sheath to be retracted from the stent graft on the  
15 pusher assembly, the fixed handle including a grip component which grips the pusher and the rotator component which grips a release clamp on the pusher, the release clamp on the pusher having trigger wires for the release of the stent graft from the pusher assembly, attached thereto and the rotator component including a screw thread with a portion of the release clamp engaged into the screw thread whereby  
20 rotational movement of the rotator component causes longitudinal movement of the release clamp on the pusher thereby pulls the trigger wires.

It will be seen that by the various forms of this invention, a device is provided which by the action of holding one portion of the deployment device and moving another portion of the deployment device in a linear sliding motion, the various  
25 sequential actions necessary to release the stent graft can occur.

#### Brief Description of the Drawing

Preferred embodiments of the invention are now described, by way of example only, with reference to the accompanying drawings, in which:

Figure 1 shows a perspective view of a deployment device according to an  
30 embodiment of the present invention;

Figure 2 shows an exploded view of the handle portion of the device shown in Figure 1;

- 5 -

Figure 3 shows an assembled and part cut away view of the handle portion of the device shown in Figure 1;

Figure 4 shows a detailed longitudinal cross-sectional view of the embodiment of Figure 1 with the stent graft partially deployed; and

5 Figures 5 to 9 show the view a detailed longitudinal cross-sectional view of the embodiment of Figure 1 at various stages of deployment.

#### Detailed Description

Throughout this discussion and as shown in Figure 1 the term proximal means the end 2 of the handle and stent graft deployment device assembly 10 and the  
10 direction proximally is the direction shown by the arrow 4. The term distal means the end 6 of the handle and stent graft deployment device assembly 10 and the direction distally is the direction shown by the arrow 8.

Now looking more closely at the drawings it will be seen that the handle and stent graft deployment device assembly 10 includes a handle portion 12 and a stent  
15 graft delivery portion 14. The delivery portion 14 is arranged to be deployed within the vasculature of a patient by the Seldinger technique to deliver and release a stent graft within the vasculature, and the handle portion 12 remains outside the patient to be manipulated to deliver and release the stent graft.

The delivery portion 14 includes a nose cone dilator 16 and a sheath 18  
20 extending from a sheath hub 20 which is engaged into the handle portion 12 with a bayonet type fitting 22. A stent graft is retained underneath the sheath 18 in the region 24 immediately distal of the nose cone dilator 16. The device is introduced into a patient over a guide wire (not shown) which passes through the guide wire catheter  
56.

25 The handle assembly 12 comprises a release handle 30 which includes a proximal grip 32 and a fixed handle 34 to which is attached a rotator component 36.

As can be seen in detail in Figure 2 the release handle 30 is formed from semi-cylindrical release halves 30a and 30b which fit together around a pusher 38 for the stent graft delivery device.

30 The fixed handle 34 is also composed of fixed handle halves 34a and 34b which together fit around the release handle 30. The pusher 38 includes a pusher hub 40 which includes pins 42 extending diametrically in each direction from the hub 40

and through a slot 44 (as can be best seen in Figure 1), that extends longitudinally along the release handle 30. The pins 42 engage into apertures 46 in the fixed handle halves 34a and 34b. The hub portion 40 also includes a release clamp 48 which slides along a portion 50 of the hub 40. The release clamp 48 includes pins 52 which extend diametrically through the slot 44 in the release handle 30 and engage into a screw thread 54 within the rotator component 36. The screw thread 54 can best be seen in Figures 1, 2 and 5 for instance.

Release or trigger wires 35 extend from each end of the stent graft 64 retained in the delivery device through a lumen 39 in the pusher 38 and a haemostatic seal within the pusher hub 40 and are fixed to the release clamp 48. The function of the release wires is discussed in more detail in relation to Figures 5 to 9.

The delivery device includes a guide wire catheter 56 and a syringe hub 58 at the distal end of the guide wire catheter 56. The guide wire catheter 56 extends through the pusher hub 40 and the lumen 39 within the pusher 38 to and through the nose cone dilator 16. The stent graft is retained concentrically around the guide wire catheter 56 immediately distal of the nose cone dilator 16.

The release handles are each substantially semi-cylindrical and when joined together form a tubular body and include inside and about half-way along their length a stepped shoulder 60 against which are engaged adjuster portions 62. The adjuster portions 62 are used to determine when the release of the stent graft has been achieved to a selected stage as will be discussed in relation to Figure 5 to 9.

Figure 3 shows a cut-away assembled view of the handle portion of the delivery device. It can be particularly seen that the slot 44 in the release handle 30 is on both sides of the release handle and the stepped shoulder 60 has the adjusters 62 engaged against it. The rotator component 36 has been omitted from Figure 3 so that the pusher hub 40 and pins 42 on the pusher hub 40 and the pins 52 on the release clamp 48 can be easily seen.

Figure 4 shows a longitudinal cross-sectional view showing a stage in the operation of the device according to the present invention.

At the stage shown in Figure 4 the fixed handle 34 and rotator component 36 have been gripped and the grip 30c on the release handle has been moved towards the fixed handle 34. The distal end 30d of the release handle 30 passes through the

engages against the release clamp 48, as will be discussed below.

A method of retention of the proximal end of a stent graft onto a introducer is disclosed in PCT Publication WO 03/101518 entitled "Trigger Wire System for a Prosthesis Deployment Device". This feature and other features disclosed in PCT  
5 Publication WO 03/101518 could be used with the present invention and the disclosure of PCT Publication WO 03/101518 is incorporated herein by reference in its entirety into this specification.

Figures 5 to 9 show the various stages in deployment of a stent graft using the deployment assembly of the present invention.

10 In Figure 5 a stent graft 64 is held in a retracted position in the region 24 immediately distal of the nose cone dilator 16. The stent graft 64 is held in a contracted state by the sheath 18 which extends back to the sheath hub 20. The stent graft 64 is also retained at least at its proximal end 64a to the delivery device by release or trigger wires 35 which extend back to the release clamp 48 through the  
15 lumen 39 of the pusher 38 and pusher hub 40 and then through the duct 41 in the pusher hub 40 and fastened to the release clamp 48. There can also be a similar release or trigger wire system for retention and release of the distal end 64b of the stent graft, and trigger wires for this extend back to the release clamp 48 through the lumen 39 of the pusher 38 and pusher hub 40 and then through the duct 41 in the  
20 pusher hub 40 and fastened to the release clamp 48.

Movement of the release clamp 48 with respect to the pusher hub 40, as discussed below, will retract the trigger wires from engagement with the stent graft 64 thereby releasing the stent graft 64. It is desirable that the proximal end 64a of the stent graft 64 is released after at least two stents of the stent graft have been exposed  
25 and allowed to expand. The rotator component 36, which engages the release clamp 48, is thus arranged to be rotated only after the adjuster portion 62 has reached a stop position against the release clamp. It is desirable, also that the trigger wire retaining the distal end 64b of the stent graft 64, if present, is only released after the stent graft is fully exposed as is shown in Figure 9. To achieve this the trigger wire is made  
30 significantly longer to extend well beyond its engagement with the stent graft 64 at the distal end 64b of the stent graft 64. This means that as the release clamp 48 continues being retracted after it has been released from the rotator component 36



stent graft 64 is released after at least two stents of the stent graft have been exposed and allowed to expand. The rotator component 36, which engages the release clamp 48, is thus arranged to be rotated only after the adjuster portion 62 has reached a stop position against the release clamp. It is desirable, also that the trigger wire retaining  
5 the distal end 64b of the stent graft 64, if present, is only released after the stent graft is fully exposed as is shown in Figure 9. To achieve this the trigger wire is made significantly longer to extend well beyond its engagement with the stent graft 64 at the distal end 64b of the stent graft 64. This means that as the release clamp 48  
10 continues being retracted after it has been released from the rotator component 36 and moved distally by its engagement with the adjuster portion 62 and the trigger wire for the distal end 64b of the stent graft is not released from its engagement until the sheath 18 has been fully retracted from the stent graft 64.

Both the fixed handle 34 and rotator component 36 are dimensioned so that the cylindrical body of the release handle 30 can pass through them as it is moved distally  
15 and the pusher hub 40 and the release clamp 48 are dimensioned so that the cylindrical body of the release handle 30 can pass around them. The adjuster portion 62 is dimensioned so that while it will pass around the pusher hub 40 it engages against the release clamp 48.

Partial retraction of the release handle 30 is shown in Figure 6. At this stage the  
20 pusher hub 40 and the release clamp 48 are retained in their positions relative to the fixed handle 34 and rotator component 36 by the pins 42 and 52 respectively engaging into them. The proximally extending exposed stent 66 on the stent graft 64 is exposed by retraction of the sheath 18 and the very proximal end 64a of the stent graft 64 has also been exposed but not to a stage where the proximal end 64a of the stent  
25 graft can start to expand under the action of its self-expanding stents.

As shown in Figure 7 continued retraction of the release handle 30 and hence also the sheath 18 with respect to the fixed handle 34 and rotator component 36 has caused the stent graft 64 to be more exposed, and the adjuster portion 62 to engage against the release clamp 48 as discussed above. This prevents further retraction.  
30 The stent graft has partially expanded under the action of its self-expanding stents. The physician can at this stage review the position of the stent graft in the vasculature and make any necessary adjustments proximally, distally or rotationally. For this

purpose the stent graft may include radiopaque markers (not shown).

When the stent graft 64 is correctly positioned the rotator component 36 can then be rotated relative to the fixed handle 34. This will cause the release clamp 48 to move distally because the pins 52 on the release clamp are engaged into the screw  
5 thread 54 until the pins exit from the distal end of the screw thread 54. This causes the trigger wires to retract from the proximal retention so that as shown in Figure 8 the exposed stent 66 is released and will expand as a self-expanding stent and engage against the wall of the vasculature into which it is deployed.

The adjuster portion 62 is then no longer prevented from moving by the release  
10 clamp 48 and hence the release handle 30 can be moved distally again as shown in Figure 9. When the adjuster portion 62 again engages the release clamp 48, which is no longer constrained by the pins engaging the screw thread, it pushes the release clamp 48 distally until the sheath 18 has fully retracted off the stent graft 64. At this stage the trigger wire which releases the distal end of the stent graft, if present, is  
15 withdrawn from engagement with the stent graft.

The entire handle and deployment device assembly can then be withdrawn from the patient. Alternatively, the sheath hub 20 can be disconnected from the release handle grip 32 by separation at the bayonet connection and the sheath 18 can be left in the patient for further operations therethrough, and the handle, pusher, guide  
20 wire catheter and nose cone dilator can be retracted through the sheath.

The disclosures in United States patent application no. US 60/964,456, from which this application claims priority, and in the abstract accompanying this application are incorporated herein by reference.

- 10 -

Claims

1. A stent graft deployment device including:  
a handle, the handle including a first part to be gripped and held by a user and a second part to be moved relative to the first part;  
5 a pusher on which a stent graft may be mounted; and  
a sheath to cover a stent graft on the pusher; wherein the pusher is connected to the first part of the handle and the sheath is connected to the second part of the handle, whereby retraction of the first part of the handle with respect to the second part of the handle causes the sheath to be retracted from a stent graft on the pusher.
- 10 2. A device as claimed in claim 1, wherein the first part of the handle includes a first component to grip the pusher and a second component to grip a release clamp on the pusher, whereby movement of the second component with respect to the first component moves the release clamp on the pusher to release the stent graft from the pusher.
- 15 3. A device as claimed in claim 2, wherein the release clamp on the pusher has attached thereto a trigger wire for the release of a stent graft from the pusher, whereby movement of the release clamp pulls the trigger wire to release the stent graft from the pusher.
4. A device as claimed in claim 2 or 3 wherein the second component is rotatable  
20 with respect to the first component, whereby rotational movement of the second component causes longitudinal movement of the release clamp on the pusher.
5. A device as claimed in claim 4, wherein the second component includes a screw thread, a portion of the release clamp being engaged in the screw thread.
6. A device as claimed in claim 4 or 5, including a detent arrangement acting  
25 between the first component and the second component to allow rotation of the second component only in a selected direction.
7. A device as claimed in any of claims 2 to 6, including a stop on the second part of the handle, the stop arranged to engage the release clamp on the pusher after a selected amount of movement of the second part of the handle has occurred, thereby  
30 to prevent further retraction of the sheath from a stent graft until the release clamp has

been moved by rotation of the second component on the first part of the handle, thereby to release the stent graft from the pusher.

8. A device as claimed in any preceding claim, wherein the second part of the handle includes a bayonet socket for a hub of the sheath.

5 9. A device as claimed in any preceding claim, wherein the second part of the handle is able to slide within the first part.

10. A device as claimed in claim 10, wherein the first part of the handle is substantially cylindrical, and wherein the second part of the handle is tubular.

10 11. A device as claimed in any preceding claim, wherein the second part of the handle has longitudinal slots and an internal lumen, the pusher extends within the longitudinal lumen, and the pusher includes arms that extend through the longitudinal slots to engage with the first part of the handle, whereby the second part of the handle can be moved with respect to the first part of the handle.

15 12. A device as claimed in any preceding claim, including a first stop to prevent the second part of the handle from moving with respect to the first part of the handle in a reverse direction.

20 13. A stent graft deployment device, the device including a tubular fixed handle to be gripped and held by a user and an elongate release handle extending through the fixed handle whereby the release handle can be moved through the fixed handle, the deployment device further including a pusher and a sheath to cover a stent graft on the pusher, the pusher being connected to the fixed handle and the sheath being connected to the release handle, whereby retraction of the release handle through the fixed handle causes the sheath to be retracted from the stent graft on the pusher.

25 14. A device as claimed in claim 13, wherein the fixed handle includes a grip component that grips the pusher and a rotator component that grips a release clamp on the pusher, whereby movement of the rotator component with respect to the grip component moves the release clamp on the pusher and thereby releases the stent graft.

30 15. A device as claimed in claim 14, wherein the release clamp on the pusher has a trigger wire for the release of the stent graft from the pusher attached thereto,

whereby movement of the release clamp pulls the trigger wire to release the stent graft.

16. A device as claimed in claim 14 or 15, wherein the rotator component is able to rotate with respect to the grip component, whereby rotational movement of the rotator component causes longitudinal movement of the release clamp on the pusher.

17. A device as claimed in claim 16, wherein the rotator component includes a screw thread with a portion of the release clamp engaged in the screw thread.

18. A device as claimed in any of claims 14 to 17, including a stop on the release handle, the stop arranged to engage the release clamp on the pusher assembly after a selected amount of movement of the release handle through the fixed handle has occurred thereby to prevent further retraction of the sheath from the stent graft until the release clamp has been moved by rotation of the rotator component on the fixed handle.

19. A device as claimed in claim 18, wherein the rotator component includes a screw thread with a portion of the release clamp engaged in the screw thread, wherein further retraction of the sheath is prevented until the release clamp has been moved out of engagement of the screw thread by rotation of the rotator component.

20. A device as claimed in any of claims 13 to 19, including a detent arrangement acting between the grip component and the rotator component of the fixed handle to allow rotation of the rotator component only in a selected direction.

21. A device as claimed in any of claims 13 to 20, wherein the release handle includes a bayonet socket for a hub of the sheath.

22. A device as claimed in any of claims 13 to 21, wherein the fixed handle includes a substantially cylindrical bore therethrough and the release handle is tubular and slides within the fixed handle.

23. A device as claimed in any of claims 13 to 22, wherein the tubular release handle has longitudinal slots therealong and an internal lumen and the pusher extends within the longitudinal lumen, and wherein the pusher assembly includes arms which extend through the longitudinal slots to engage with the fixed handle, whereby the release handle can be moved with respect to the fixed handle to move the sheath with

respect to the pusher.

24. A device as claimed in any of claims 13 to 23, including a first stop to prevent the release handle from moving through the fixed handle in a reverse direction.

25. A stent graft deployment device including:

5 a handle, the handle including a tubular fixed handle to be gripped and held by a user and an elongate release handle extending through the fixed handle whereby the release handle can be moved through the fixed handle;

10 a pusher and a sheath to cover a stent graft on the pusher, the pusher being connected to the fixed handle and the sheath being connected to the release handle, whereby retraction of the release handle through the fixed handle causes the sheath to be retracted from a stent graft on the pusher;

the fixed handle including a grip component that grips the pusher and a rotator component that grips a release clamp on the pusher;

15 the release clamp on the pusher having a trigger wire for the release of a stent graft from the pusher attached thereto; and

the rotator component including a screw thread with a portion of the release clamp engaged into the screw thread, whereby rotational movement of the rotator component causes longitudinal movement of the release clamp on the pusher thereby to pull the trigger wires.

20 26. An assembly of a stent graft deployment device as claimed in any preceding claim and a stent graft mounted on the pusher.

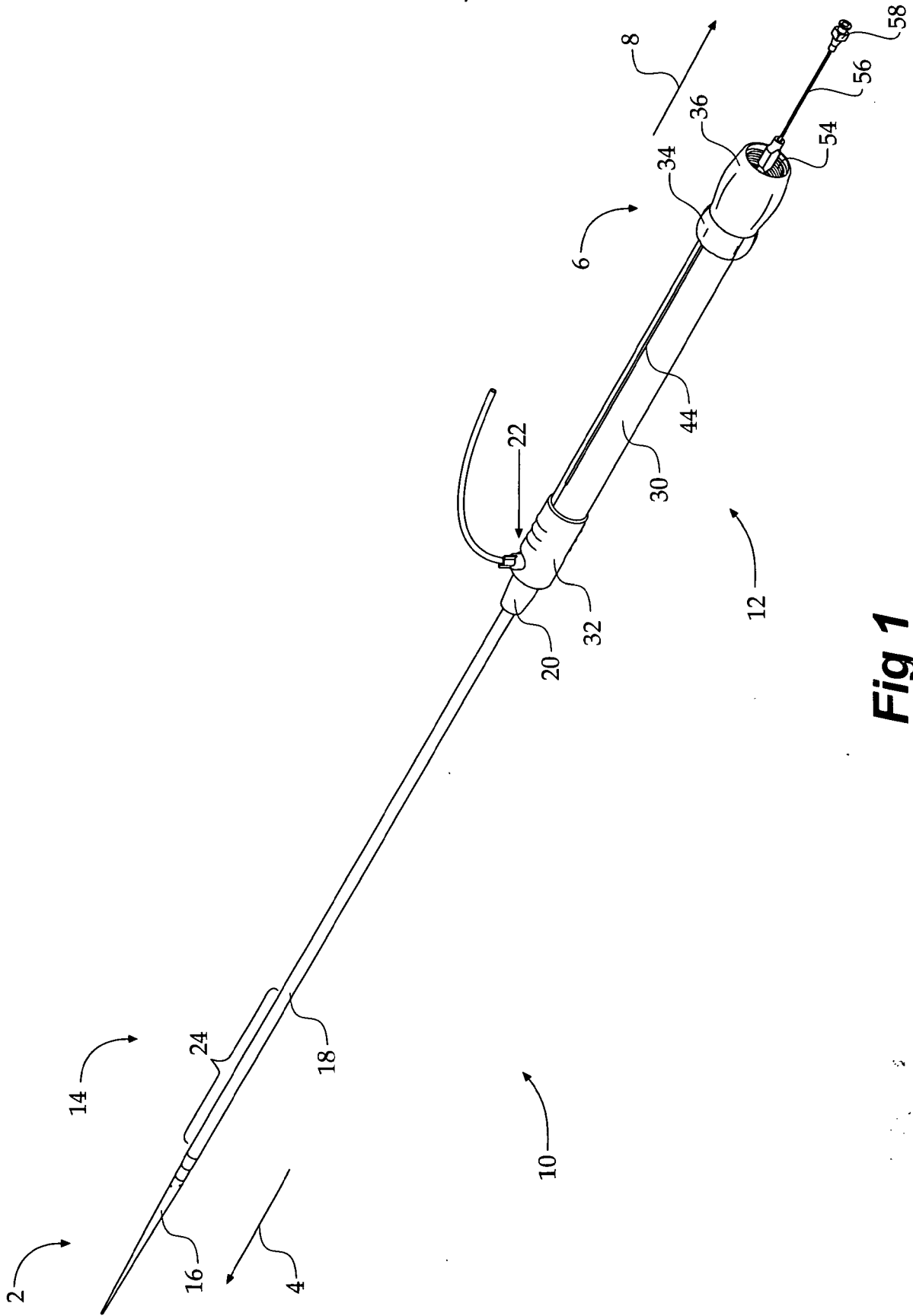

**Fig 1**

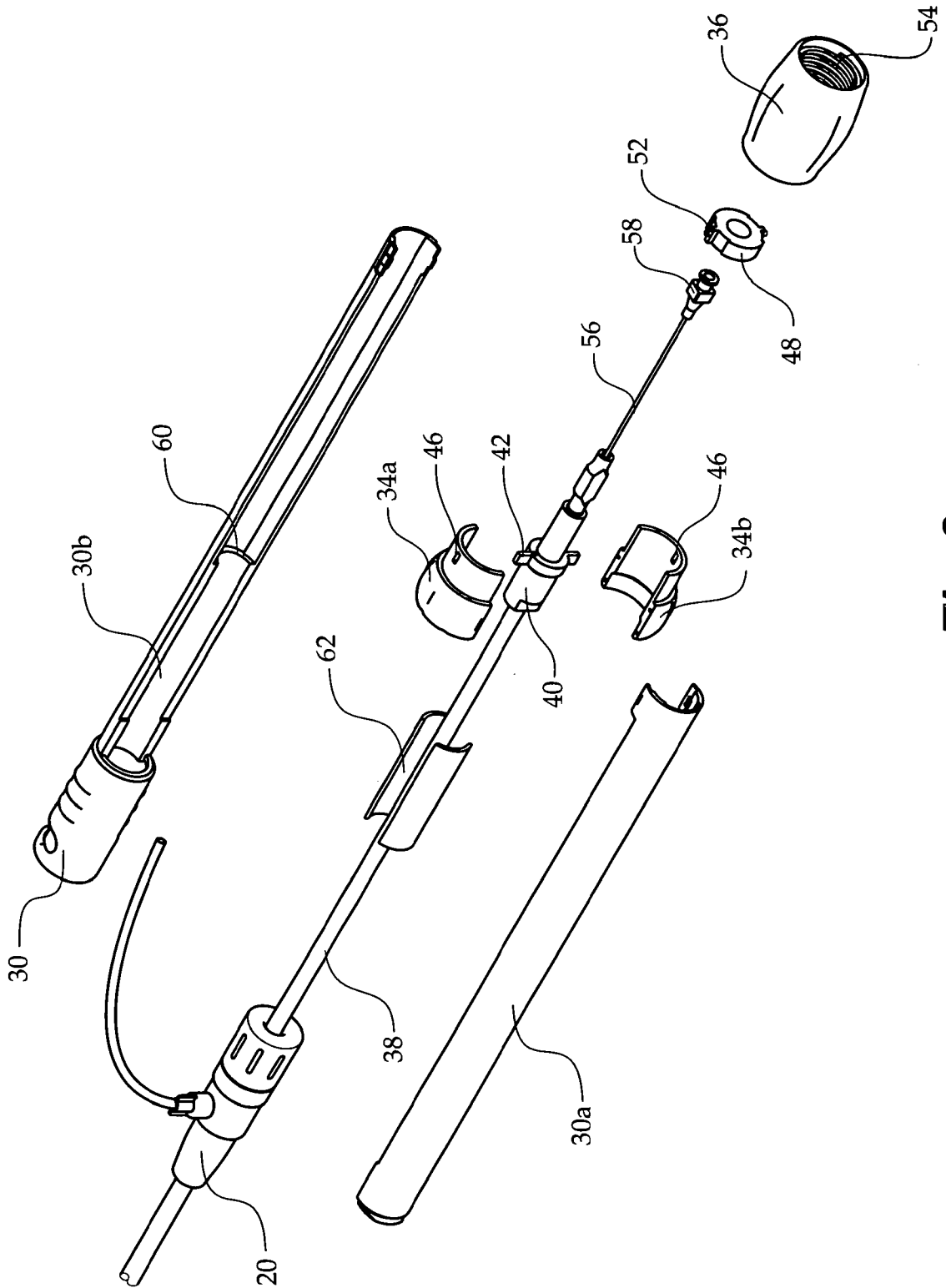

Fig 2



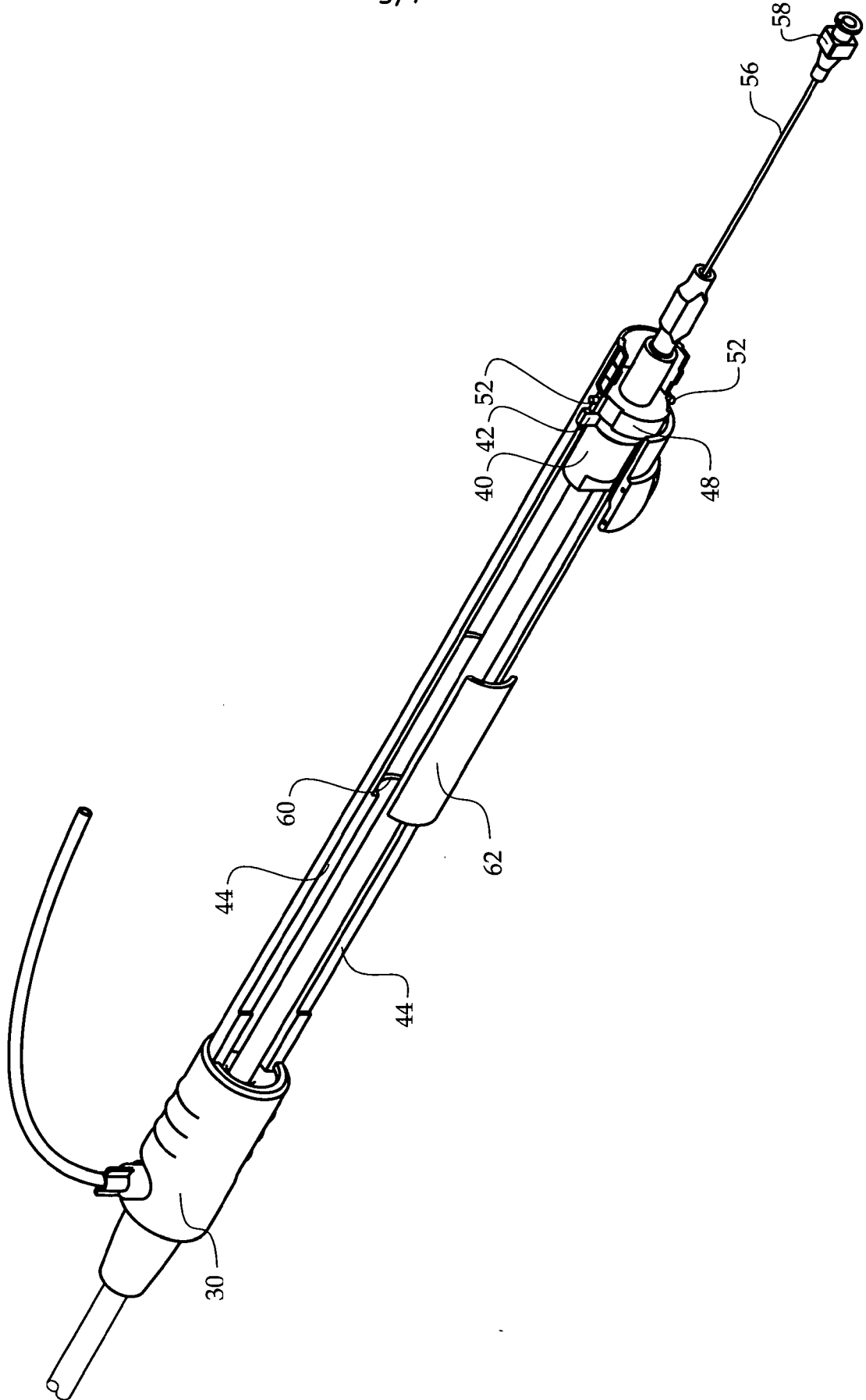
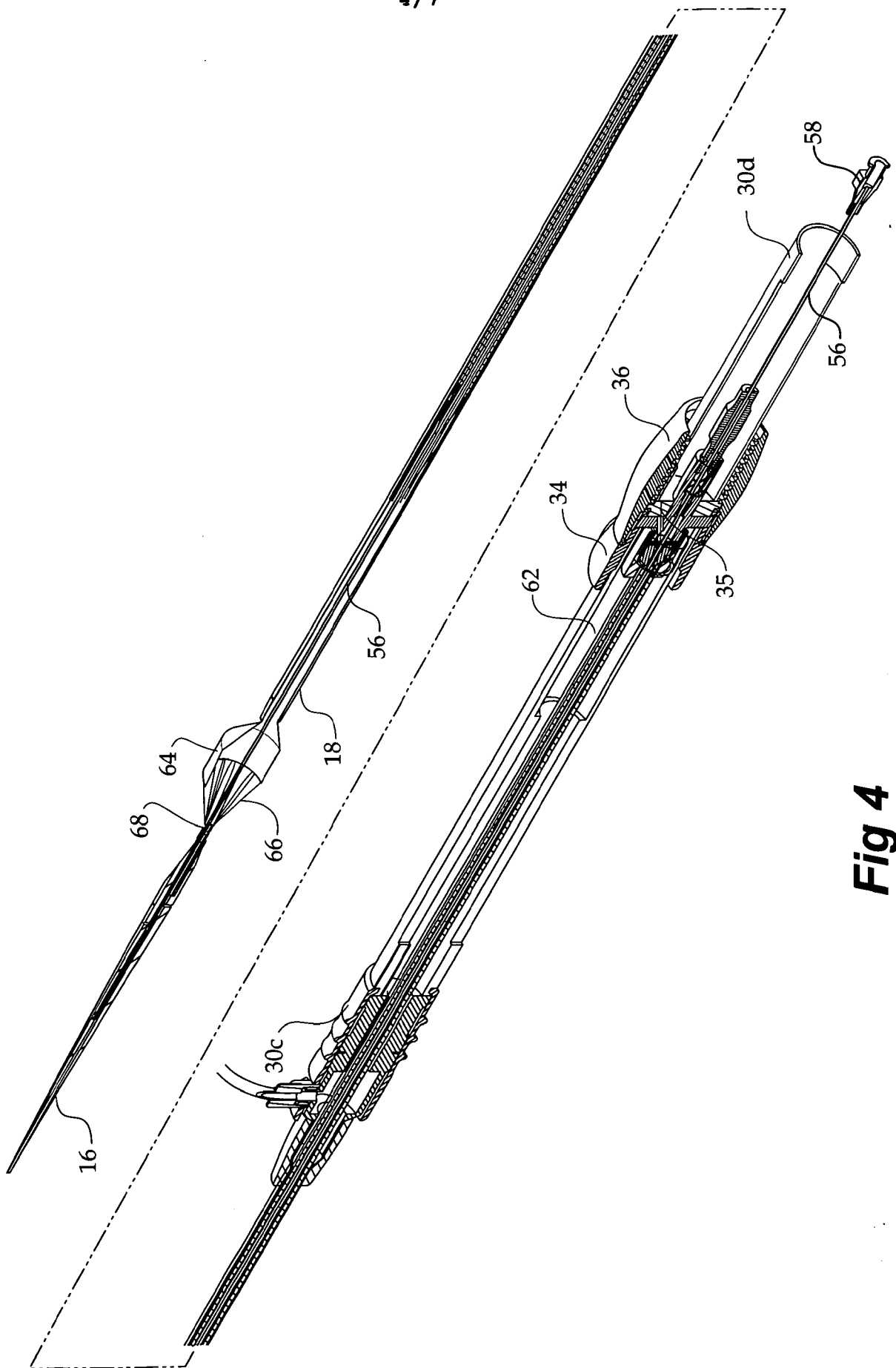

Fig 3



**Fig 4**

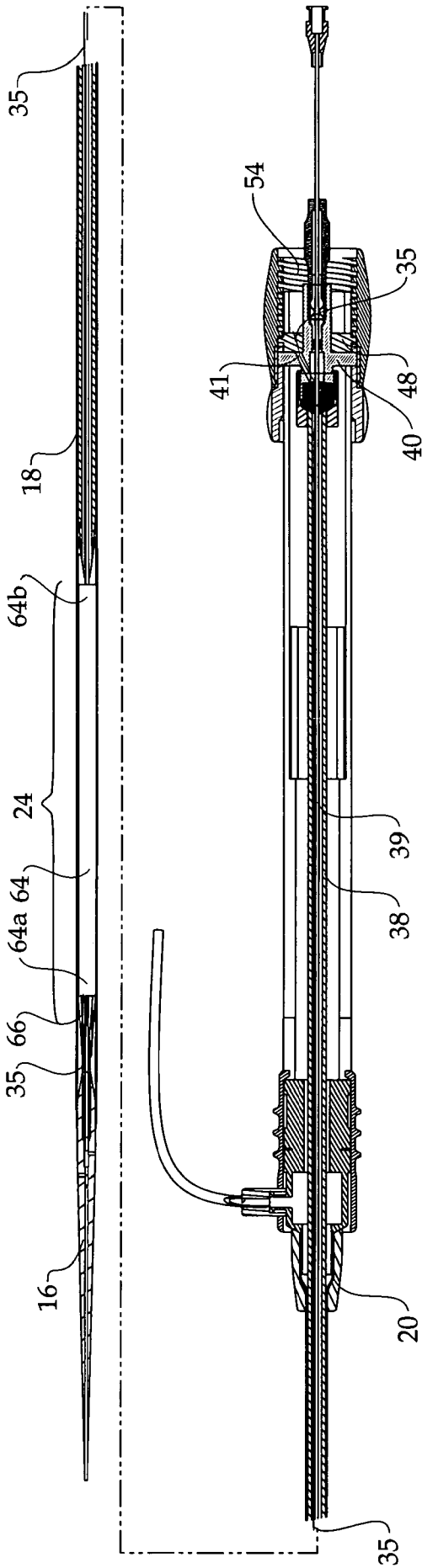

Fig 5

5/7

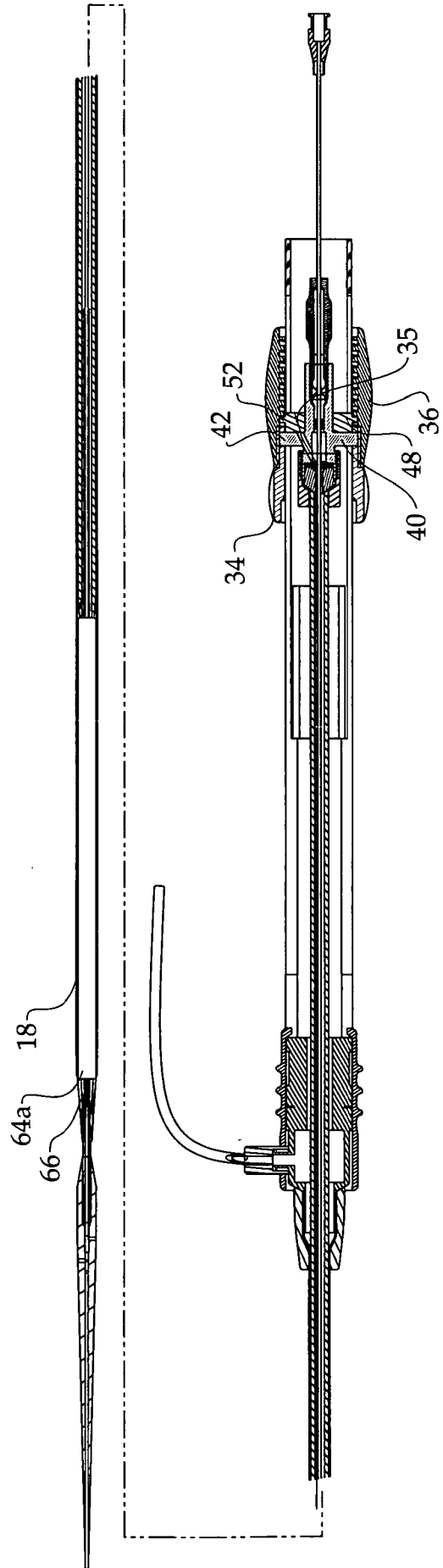
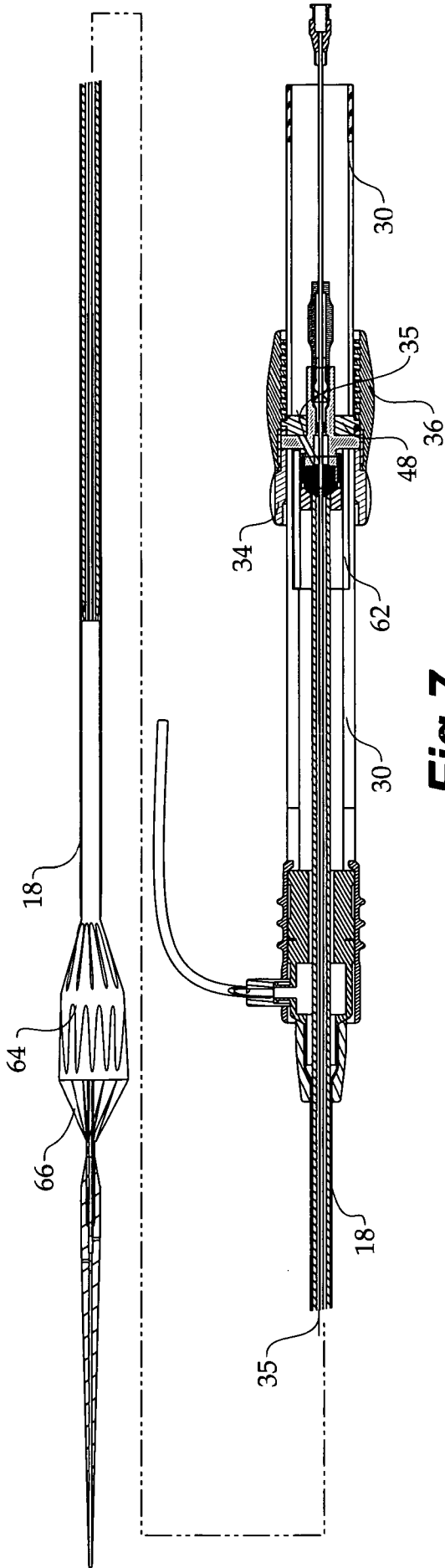
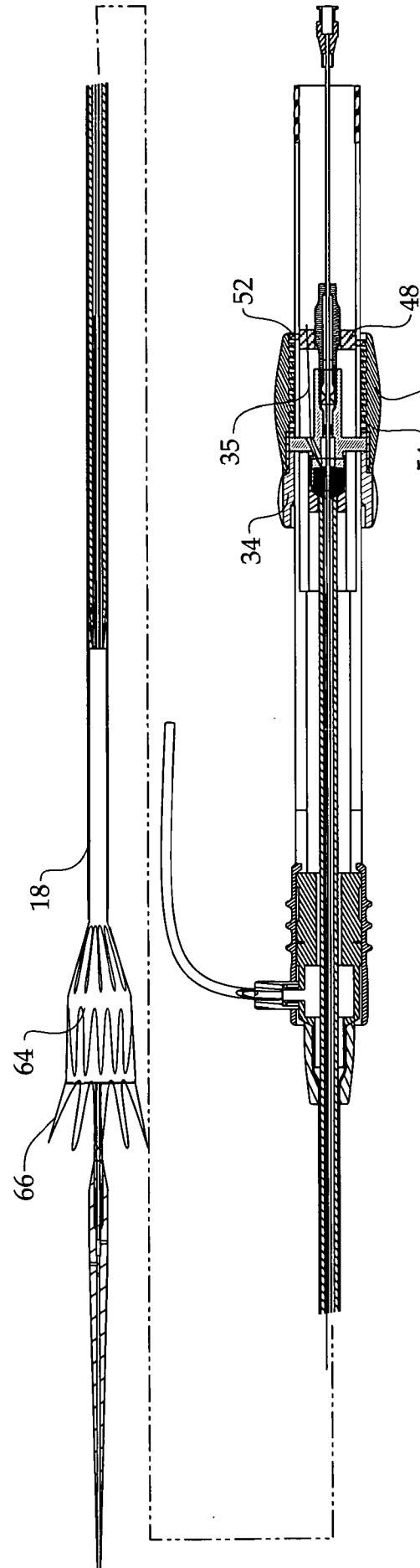

Fig 6



**Fig 7**



**Fig 8**

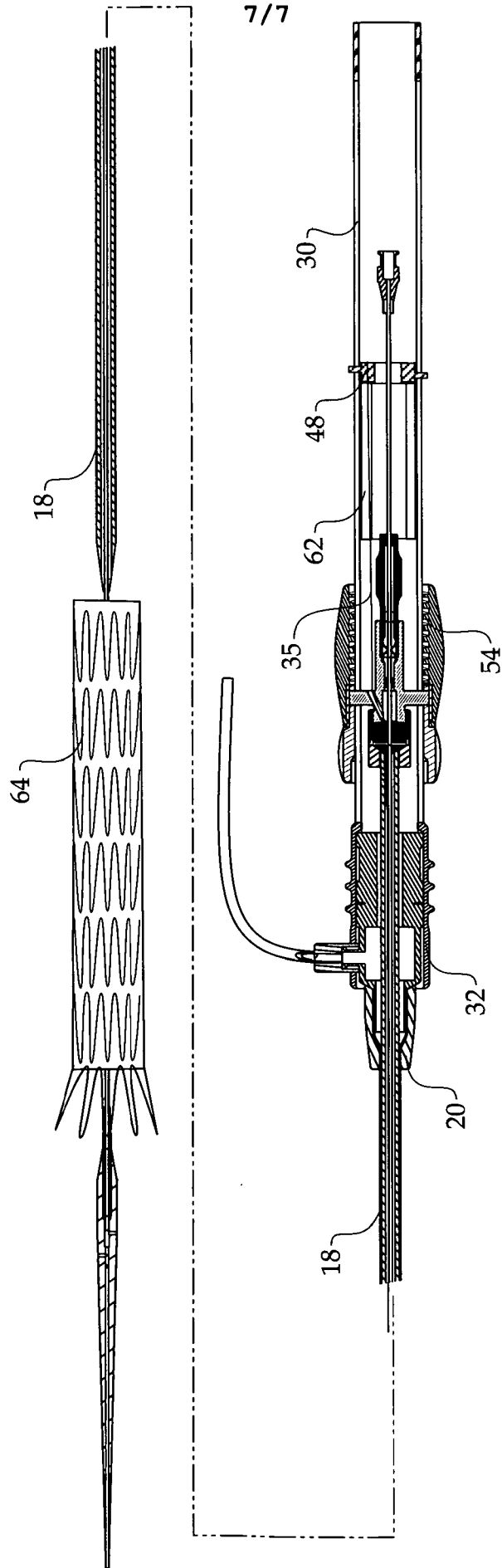

**Fig 9**

# INTERNATIONAL SEARCH REPORT

International application No  
PCT/US2008/009685

**A. CLASSIFICATION OF SUBJECT MATTER**  
INV. A61F2/84

According to International Patent Classification (IPC) or to both national classification and IPC

**B. FIELDS SEARCHED**

Minimum documentation searched (classification system followed by classification symbols)  
A61F

Documentation searched other than minimum documentation to the extent that such documents are included in the fields searched

Electronic data base consulted during the international search (name of data base and, where practical, search terms used)

EPO-Internal

**C. DOCUMENTS CONSIDERED TO BE RELEVANT**

Category*	Citation of document, with indication, where appropriate, of the relevant passages	Relevant to claim No.
X	WO 2006/071915 A (COOK INC [US]) 6 July 2006 (2006-07-06) paragraphs [0028] - [0031], [0033] - [0036] figures 3-5,7-11	1,8-13, 21-24,26
A	----- US 5 776 142 A (GUNDERSON RICHARD C [US]) 7 July 1998 (1998-07-07) column 2, lines 12-17 column 4, line 25 - column 5, line 21 figures 1,2 -----	2,3,14, 15,25
A	----- US 5 776 142 A (GUNDERSON RICHARD C [US]) 7 July 1998 (1998-07-07) column 2, lines 12-17 column 4, line 25 - column 5, line 21 figures 1,2 -----	1-3
	-/--	

Further documents are listed in the continuation of Box C.

See patent family annex.

\* Special categories of cited documents :

- \*A\* document defining the general state of the art which is not considered to be of particular relevance
- \*E\* earlier document but published on or after the international filing date
- \*L\* document which may throw doubts on priority claim(s) or which is cited to establish the publication date of another citation or other special reason (as specified)
- \*O\* document referring to an oral disclosure, use, exhibition or other means
- \*P\* document published prior to the international filing date but later than the priority date claimed

- \*T\* later document published after the international filing date or priority date and not in conflict with the application but cited to understand the principle or theory underlying the invention
- \*X\* document of particular relevance; the claimed invention cannot be considered novel or cannot be considered to involve an inventive step when the document is taken alone
- \*Y\* document of particular relevance; the claimed invention cannot be considered to involve an inventive step when the document is combined with one or more other such documents, such combination being obvious to a person skilled in the art.
- \*&\* document member of the same patent family

Date of the actual completion of the international search

6 November 2008

Date of mailing of the international search report

17/11/2008

Name and mailing address of the ISA/

European Patent Office, P.B. 5818 Patentlaan 2  
 NL - 2280 HV Rijswijk  
 Tel. (+31-70) 340-2040,  
 Fax: (+31-70) 340-3016

Authorized officer

Chevalot, Nicolas

## INTERNATIONAL SEARCH REPORT

International application No  
PCT/US2008/009685

C(Continuation). DOCUMENTS CONSIDERED TO BE RELEVANT		
Category*	Citation of document, with indication, where appropriate, of the relevant passages	Relevant to claim No.
A	EP 1 369 098 A (MEDTRONIC AVE INC [US]) 10 December 2003 (2003-12-10) paragraphs [0010], [0011], [0045] figures 1-4,9 -----	1-5, 13-17
X	WO 2006/007389 A (COOK INCORPRATED [US]; WILLIAM COOK AUSTRALIA PTY LTD [AU]; GREENBERG) 19 January 2006 (2006-01-19) page 17, line 10 - page 18, line 27 figures 5,6 -----	1,10,12, 26
A	-----	2,3, 13-15, 24,25
A	US 6 533 811 B1 (RYAN TIMOTHY J [US] ET AL) 18 March 2003 (2003-03-18) column 3, line 54 - column 4, line 50 figure 4 -----	1-5, 13-15
A	EP 1 358 903 A (MEDTRONIC AVE INC [US]) 5 November 2003 (2003-11-05)  paragraphs [0016] - [0049] figures 1-6 -----	1,2,7, 13,14, 18,19
A	US 2005/049667 A1 (ARBEFEUILLE SAMUEL [US] ET AL) 3 March 2005 (2005-03-03)  paragraphs [0166] - [0179] figures 10-14,19-25 -----	1-4, 8-10, 13-17, 20-22, 25,26
P,X	WO 2007/127351 A (COOK INC [US]; COOK WILLIAM A AUSTRALIA [AU]; CHUTER TIMOTHY A [US]; L) 8 November 2007 (2007-11-08)  page 11, line 4 - page 14, line 15 figures 3A-3D -----	1-3,8,9, 12,13, 21,22, 24,26

# INTERNATIONAL SEARCH REPORT

Information on patent family members

International application No PCT/US2008/009685
---

Patent document cited in search report	A	Publication date	Patent family member(s)	Publication date
WO 2006071915	A	06-07-2006	EP 1833431 A2	19-09-2007
US 5776142	A	07-07-1998	NONE	
EP 1369098	A	10-12-2003	JP 2004130068 A US 2004093063 A1	30-04-2004 13-05-2004
WO 2006007389	A	19-01-2006	AU 2005262541 A1 CA 2573889 A1 EP 1765221 A1	19-01-2006 19-01-2006 28-03-2007
US 6533811	B1	18-03-2003	NONE	
EP 1358903	A	05-11-2003	JP 2003334254 A US 2003199966 A1 US 2005027305 A1	25-11-2003 23-10-2003 03-02-2005
US 2005049667	A1	03-03-2005	AU 2004270186 A1 BR PI0414109 A EP 1673033 A2 JP 2007503923 T KR 20060072137 A US 2006129224 A1 US 2006276872 A1 US 2007203566 A1 US 2007163668 A1 US 2007142894 A1 US 2007135818 A1 US 2005049674 A1 WO 2005023149 A2	17-03-2005 31-10-2006 28-06-2006 01-03-2007 27-06-2006 15-06-2006 07-12-2006 30-08-2007 19-07-2007 21-06-2007 14-06-2007 03-03-2005 17-03-2005
WO 2007127351	A	08-11-2007	US 2007260301 A1 WO 2007127352 A1	08-11-2007 08-11-2007