



HU000035539T2

(19) **HU**(11) Lajstromszám: **E 035 539**(13) **T2****MAGYARORSZÁG**
Szellemi Tulajdon Nemzeti Hivatala**EURÓPAI SZABADALOM**
SZÖVEGÉNEK FORDÍTÁSA

- (21) Magyar ügyszám: **E 10 178725**
- (22) A bejelentés napja: **2004. 10. 21.**
- (96) Az európai bejelentés bejelentési száma:
EP 20040178725
- (97) Az európai bejelentés közzétételi adatai:
EP 2259164 A1 **2010. 12. 08.**
- (97) Az európai szabadalom megadásának meghirdetési adatai:
EP 2259164 B1 **2017. 12. 06.**
- (51) Int. Cl.: **G06F 1/20** (2006.01)
H01L 23/552 (2006.01)
H01L 23/373 (2006.01)
G06F 1/18 (2006.01)

(30) Elsőbbségi adatok: 722364 2003. 11. 25. US	(73) Jogosult(ak): NeoGraf Solutions, LLC, Lakewood OH 44107 (US)
(72) Feltalálók(k): Smalc, Martin David, Parma, OH (US) Shives, Gary D., Brunswick, OH (US) Reynolds III, Robert Anderson, Bay Village, OH (US)	(74) Képviselő: Danubia Szabadalmi és Jogi Iroda Kft., Budapest

(54) **Hűtési megoldás elektronikus eszközökhöz**

Az európai szabadalom ellen, megadásának az Európai Szabadalmi Közlönyben való meghirdetésétől számított kilenc hónapon belül, felszólalást lehet benyújtani az Európai Szabadalmi Hivatalnál. (Európai Szabadalmi Egyezmény 99. cikk(1))

A fordítást a szabadalmas az 1995. évi XXXIII. törvény 84/H. §-a szerint nyújtotta be. A fordítás tartalmi helyességét a Szellemi Tulajdon Nemzeti Hivatala nem vizsgálta.

(19)



(11)

EP 2 259 164 B1

(12)

EUROPEAN PATENT SPECIFICATION

(45) Date of publication and mention of the grant of the patent:
06.12.2017 Bulletin 2017/49

(51) Int Cl.:
G06F 1/20 (2006.01) **G06F 1/18** (2006.01)
H01L 23/373 (2006.01) **H01L 23/552** (2006.01)

(21) Application number: **10178725.7**

(22) Date of filing: **21.10.2004**

(54) Thermal solution for electronic devices

Thermische Lösung für elektronische Vorrichtungen

Solution thermique pour dispositifs électroniques

(84) Designated Contracting States:
AT BE BG CH CY CZ DE DK EE ES FI FR GB GR HU IE IT LI LU MC NL PL PT RO SE SI SK TR

(30) Priority: **25.11.2003 US 722364**

(43) Date of publication of application:
08.12.2010 Bulletin 2010/49

(62) Document number(s) of the earlier application(s) in accordance with Art. 76 EPC:
08169306.1 / 2 026 164
04256484.9 / 1 536 313

(73) Proprietor: **Advanced Energy Technologies LLC**
Lakewood OH 44107 (US)

(72) Inventors:
 • **Smalc, Martin David**
Parma, OH (US)
 • **Shives, Gary D.**
Brunswick, OH (US)
 • **Reynolds III, Robert Anderson**
Bay Village, OH (US)

(74) Representative: **Brand, Thomas Louis et al**
TL Brand & Co
17 Hanover Square
London W1S 1BN (GB)

(56) References cited:
EP-A- 1 041 627 **WO-A-03/001133**
JP-A- 7 109 171 **JP-A- 2003 008 263**
US-A- 5 390 734 **US-A- 5 930 115**

EP 2 259 164 B1

Note: Within nine months of the publication of the mention of the grant of the European patent in the European Patent Bulletin, any person may give notice to the European Patent Office of opposition to that patent, in accordance with the Implementing Regulations. Notice of opposition shall not be deemed to have been filed until the opposition fee has been paid. (Art. 99(1) European Patent Convention).

Description**Technical Field**

5 [0001] The present invention relates to a thermal solution capable of managing the heat from a heat source such as a component of an electronic device, so as to dissipate heat generated by the heat source while mediating the effects of the heat on users of the device and other device components.

Background of the Invention

10 [0002] With the development of more and more sophisticated electronic devices, including those capable of increasing processing speeds and higher frequencies, having smaller size and more complicated power requirements, and exhibiting other technological advances, such as microprocessors and integrated circuits in electronic and electrical components, high capacity and response memory components such as hard drives, electromagnetic sources such as light bulbs in
15 digital projectors, as well as in other devices such as high power optical devices, relatively extreme temperatures can be generated. However, microprocessors, integrated circuits and other sophisticated electronic components typically operate efficiently only under a certain range of threshold temperatures. The excessive heat generated during operation of these components can not only harm their own performance, but can also degrade the performance and reliability of the overall system and can even cause system failure. The increasingly wide range of environmental conditions, including
20 temperature extremes, in which electronic systems are expected to operate, exacerbates the negative effects of excessive heat.

[0003] With the increased need for heat dissipation from microelectronic devices, thermal management becomes an increasingly important element of the design of electronic products. Both performance reliability and life expectancy of electronic equipment are inversely related to the component temperature of the equipment. For instance, a reduction in
25 the operating temperature of a device such as a typical silicon semiconductor can correspond to an increase in the processing speed, reliability and life expectancy of the device. Therefore, to maximize the life-span and reliability of a component, controlling the device operating temperature within the limits set by the designers is of paramount importance.

[0004] In addition, the increasing desire for smaller and more compact electronics, such as laptop computers, cell phones, digital cameras and projectors, etc., means that the heat source will be adjacent external surfaces of the device and adjacent other components. As such, external surfaces of the device can become heated, which can be uncomfortable or even dangerous to the user. Moreover, the heat generated by one component in a device can adversely affect an adjacent component. Although one potential solution is to insulate the heat source, this is not a satisfactory solution, since doing so keeps the heat generated by the heat source concentrated at the heat source, potentially damaging the heat source.
30

[0005] For instance, in some laptop computers, the hard drive, which can generate substantial amounts of heat, is located beneath one of the so-called "palm rests" of the computer - the area between the keyboard and the user, where the users palm is normally resting while typing. In thinner laptops, the heat generated by the hard drive can be transferred through the laptop case to the user's palm, causing discomfort and even pain. Indeed, in some laptops, the palm rest temperature has been measured to be higher than 40°C. Likewise, heat-generating components can cause the bottom
35 of a laptop computer to become heated, causing discomfort or even pain to the user when the laptop is positioned in the user's lap. This has become a significant problem for makers of laptop computers, and other portable devices where there is a continuing effort to make the devices smaller for greater portability.

[0006] One group of relatively light weight materials suitable for use in the dissipation of heat from heat sources such as electronic components are those materials generally known as graphites, but in particular graphites such as those
40 based on natural graphites and flexible graphite as described below. These materials are anisotropic and allow thermal dissipation devices to be designed to preferentially transfer heat in selected directions. The graphite materials are much lighter in weight and thus provide many advantages over copper or aluminum.

[0007] Graphites are made up of layer planes of hexagonal arrays or networks of carbon atoms. These layer planes of hexagonally arranged carbon atoms are substantially flat and are oriented or ordered so as to be substantially parallel and equidistant to one another. The substantially flat, parallel equidistant sheets or layers of carbon atoms, usually referred to as graphene layers or basal planes, are linked or bonded together and groups thereof are arranged in
45 crystallites. Highly ordered graphites consist of crystallites of considerable size: the crystallites being highly aligned or oriented with respect to each other and having well ordered carbon layers. In other words, highly ordered graphites have a high degree of preferred crystallite orientation. It should be noted that graphites possess anisotropic structures and thus exhibit or possess many properties that are highly directional e.g. thermal and electrical conductivity and fluid diffusion.
50

[0008] Briefly, graphites may be characterized as laminated structures of carbon, that is, structures consisting of superposed layers or laminae of carbon atoms joined together by weak van der Waals forces. In considering the graphite
55

structure, two axes or directions are usually noted, *to wit*, the "c" axis or direction and the "a" axes or directions. For simplicity, the "c" axis or direction may be considered as the direction perpendicular to the carbon layers. The "a" axes or directions may be considered as the directions parallel to the carbon layers or the directions perpendicular to the "c" direction. The graphites suitable for manufacturing flexible graphite sheets possess a very high degree of orientation.

5 [0009] As noted above, the bonding forces holding the parallel layers of carbon atoms together are only weak van der Waals forces. Natural graphites can be treated so that the spacing between the superposed carbon layers or laminae can be appreciably opened up so as to provide a marked expansion in the direction perpendicular to the layers, that is, in the "c" direction, and thus form an expanded or intumesced graphite structure in which the laminar character of the carbon layers is substantially retained.

10 [0010] Graphite flake which has been greatly expanded and more particularly expanded so as to have a final thickness or "c" direction dimension which is as much as about 80 or more times the original "c" direction dimension can be formed without the use of a binder into cohesive or integrated sheets of expanded graphite, e.g. webs, papers, strips, tapes, foils, mats or the like (typically referred to as "flexible graphite"). The formation of graphite particles which have been expanded to have a final thickness or "c" dimension which is as much as about 80 times or more the original "c" direction dimension into integrated flexible sheets by compression, without the use of any binding material, is believed to be possible due to the mechanical interlocking, or cohesion, which is achieved between the voluminously expanded graphite particles.

15 [0011] In addition to flexibility, the sheet material, as noted above, has also been found to possess a high degree of anisotropy with respect to thermal and electrical conductivity and fluid diffusion, comparable to the natural graphite starting material due to orientation of the expanded graphite particles and graphite layers substantially parallel to the opposed faces of the sheet resulting from very high compression, e.g. roll pressing. Sheet material thus produced has excellent flexibility, good strength and a very high degree of orientation.

20 [0012] Briefly, the process of producing flexible, binderless anisotropic graphite sheet material, e.g. web, paper, strip, tape, foil, mat, or the like, comprises compressing or compacting under a predetermined load and in the absence of a binder, expanded graphite particles which have a "c" direction dimension which is as much as about 80 or more times that of the original particles so as to form a substantially flat, flexible, integrated graphite sheet. The expanded graphite particles that generally are worm-like or vermiform in appearance, once compressed, will maintain the compression set and alignment with the opposed major surfaces of the sheet. The density and thickness of the sheet material can be varied by controlling the degree of compression. The density of the sheet material can be within the range of from about 0,04 g/cm³ to about 2.0 g/cm³. The flexible graphite sheet material exhibits an appreciable degree of anisotropy due to the alignment of graphite particles parallel to the major opposed, parallel surfaces of the sheet, with the degree of anisotropy increasing upon roll pressing of the sheet material to increase orientation. In roll pressed anisotropic sheet material, the thickness, *i.e.* the direction perpendicular to the opposed, parallel sheet surfaces comprises the "c" direction and the directions ranging along the length and width, *i.e.* along or parallel to the opposed, major surfaces comprises the "a" directions and the thermal, electrical and fluid diffusion properties of the sheet are very different, by orders of magnitude, for the "c" and "a" directions.

30 [0013] While the use of sheets of compressed particles of exfoliated graphite (*i.e.*, flexible graphite) has been suggested as thermal spreaders, thermal interfaces and as component parts of heat sinks for dissipating the heat generated by a heat source (see, for instance, U.S. Patent Nos. 6,245,400; 6,482,520; 6,503,626; and 6,538,892), the issues of "touch temperature," that is the heating of external surfaces of an electronic device to the extent that the user is discomfited or endangered, and heating of adjacent components have not adequately been addressed.

35 [0014] Accordingly, there is a continuing need for improved designs for thermal solutions for electronic components of portable or miniaturized devices where the heat from the component needs to be blocked from effecting neighboring components or from discomfiting or endangering users of the device, while also being dissipated.

40 [0015] EP2259164 discloses a thermal solution for an electronic device, which is positioned between a heat source and an external surface of the electronic device and/or another component of the electronic device. The thermal solution facilitates heat dissipation from the heat source while shielding the external surface and/or second component from the heat generated by the heat source.

45 [0016] WO03001133 discloses a process for forming an anisotropic heat spreader or heat pipe. There is disclosed forming a laminate comprising a plurality of flexible graphite sheets which comprise graphene layers; and directionally aligning the graphene layers of the laminate.

50 [0017] US5930115 discloses a thermal management structure to provide mechanical isolation and heat removal for an unpackaged semiconductor die mounted directly on a printed circuit board substrate. The thermal management structure sandwiches the unpackaged semiconductor die and substrate between two heat sink pieces which are rigidly mounted to the substrate, thereby mechanically isolating the unpackaged semiconductor die and preventing the die from being accidentally touched. The two heat sink pieces further compliantly thermally engage selected sites on the exposed face of the semiconductor die and the surface of the substrate to conductively remove heat away from the substrate. The thermal management structure may also provide electromagnetic shielding which isolates the electro-

magnetic fields generated by the substrate from electromagnetic fields external to the thermal management structure. The thermal management structure may also thermally engage selected thermally conductive components within an end product to spread the heat throughout the system.

5 Summary of the Invention

10 [0018] The present invention provides a thermal solution capable of dissipating the heat from an electronic component while simultaneously shielding a user or adjacent components from the effects of the heat generated by the component. The inventive thermal solution comprises an anisotropic sheet of compressed particle of exfoliated graphite (also referred to herein as "flexible graphite"). As used herein, the term "flexible graphite" also refers to sheets of pyrolytic graphite, either singly or as a laminate. The flexible graphite sheet employed as the thermal solution of the present invention has an in-plane thermal conductivity substantially higher than its through-plane thermal conductivity. In other words, the thermal solution of the present invention has a relatively high (on the order of 10 or greater) thermal anisotropic ratio. The thermal anisotropic ratio is the ratio of in-plane thermal conductivity to through-plane thermal conductivity.

15 [0019] The thermal solution comprises two major surfaces, one of which is in operative contact with a surface of the heat source like a hard drive or the casing of the light source in a digital projector. The area of the thermal solution is greater than that of the area of contact of the thermal solution on the heat source, such that the in-plane thermal conductivity of the thermal solution acts to dissipate heat from the heat source. Most advantageously one of the major surfaces of the thermal solution (not necessarily the same major surface that is in contact with the heat source) is also in operative contact with a heat dissipation device such as a heat sink so that heat generated by the heat source is spread through the thermal solution due to its relatively high in-plane thermal conductivity and conducted to the heat sink where it is dissipated.

20 [0020] Due to the relatively low through-thickness thermal conductivity (or, put another way, high thermal anisotropic ratio), the heat generated by the heat source is not as readily transferred through the thermal solution. Thus, when the thermal solution is positioned between the heat source and an external surface of the device in which the heat source is located, or between the heat source and another component in the device in which the heat source is located, the thermal solution reduces or eliminates heat flow from the heat source to the external surface or other component. The conformable nature of the thermal solution of the present invention permits its use even in applications where space is limited.

25 [0021] In addition, another benefit of the use of a flexible graphite material as the inventive thermal solution lies in the ability of graphitic materials to block electromagnetic and radio frequency (EMI/RF) interference. It is believed that the thermal solutions of this invention will function to shield components of the device in which it is positioned from EMI/RF interference, in addition to performing the thermal dissipation/shielding function that is its primary purpose.

30 [0022] In another embodiment of the invention, the thermal solution can have a layer of aluminum or other isotropic conductor like copper laminated or coated thereon so as to be interposed between the thermal solution and the surface of the heat source to improve handleability and mechanical robustness of the thermal solution, as well as to modify the thermal transfer and EMI/RF shielding characteristics of the thermal solution. Likewise, a thermal interface material, such as a thermal grease or a graphite-based thermal interface like that described in International Patent No. WO03057475 and/or commercially available from Advanced Energy Technology Inc. of Lakewood, Ohio as its eGraf Hi-Therm™ line of products can be interposed between the thermal solution and the heat source to facilitate heat transfer between the heat source and the inventive thermal solution.

35 [0023] In addition, in order to improve mechanical robustness and handleability of the thermal solution and potentially to further block or shield heat from being transmitted from the heat source to the external surface of the device or to other device components, a layer of a relatively thermally non-conductive material such as a plastic like Mylar® material or other resins or like materials can be overlaid on the thermal solution.

40 [0024] The use of a layer of aluminum, plastic, etc. on one or both of the major surfaces of the thermal solution can have an additional advantage. Although they are not believed to be well-founded, fears have been expressed that the use of a graphite component within an electronic device can lead to problems due to flaking of graphite particles from the graphite component. The aluminum, plastic, etc. can also function or cooperate to encase the graphite thermal solution, thus eliminating any practical possibility of graphite flaking.

45 [0025] Accordingly it is an object of the present invention to provide an improved thermal solution for simultaneously dissipating the heat from a component of an electronic device and shielding adjacent structures from the heat.

[0026] Still another object of the present invention is the provision of a thermal solution having a sufficiently high thermal anisotropic ratio to function effectively for heat dissipation while avoiding heat transfer to adjacent structures

50 [0027] Yet another object of the present invention is the provision of a conformable thermal solution which provides both heat dissipation and heat blocking in an environment where available space is limited.

[0028] These objects and others which will be apparent to the skilled artisan upon reading the following description. can be achieved by providing a thermal dissipation and shielding system for an electronic device, according to claim 1.

The thermal solution preferably has an in-plane thermal conductivity of at least about 140 W/m²K, more preferably at least about 200 W/m²K and a through-plane thermal conductivity of no greater than about 12 W/m²K, more preferably no greater than about 10 W/m²K.

[0029] Advantageously, the inventive system further includes a heat dissipation device such as a heat sink, heat pipe, heat plate or combinations thereof, positioned in a location not directly adjacent to the first component and further wherein one of the major surfaces of the thermal solution is in operative contact with the heat dissipation device.

[0030] In another embodiment of the invention the thermal solution can have a protective coating, such as a plastic, thereon. Most preferably the protective coating has a thermal conductivity less than the through-plane thermal conductivity of the at least one sheet of flexible graphite. A thermal transfer material, like a metal or a thermal interface, can also be positioned between the thermal solution and the first component.

[0031] It is to be understood that both the foregoing general description and the following detailed description present embodiments of the invention, and are intended to provide an overview or framework for understanding the nature and character of the invention as it is claimed. The accompanying drawings are included to provide a further understanding of the invention, and are incorporated in and constitute a part of this specification. The drawings illustrate various embodiments of the invention, and together with the description serve to explain the principles and operations of the invention.

Brief Description Of The Drawings

[0032]

Fig. 1 is a perspective view of a first embodiment of the thermal solution of the present invention disposed to bridge a heat source and a heat sink.

Fig. 2a is a perspective view of a laptop computer having its top plate removed.

Fig. 2b is a perspective view of the thermal solution embodiment of Fig. 1 positioned *in situ* in the laptop computer of Fig. 2a.

Fig. 3 is a cross-sectional view of a second embodiment of the thermal solution of the present invention having plastic and aluminum overlays.

Detailed Description Of The Preferred Embodiments

[0033] As noted, the inventive thermal solution is formed from sheets of compressed particles of exfoliated graphite, commonly known as flexible graphite. Graphite is a crystalline form of carbon comprising atoms covalently bonded in flat layered planes with weaker bonds between the planes. By treating particles of graphite, such as natural graphite flake, with an intercalant of, e.g. a solution of sulfuric and nitric acid, the crystal structure of the graphite reacts to form a compound of graphite and the intercalant. The treated particles of graphite are hereafter referred to as "particles of intercalated graphite." Upon exposure to high temperature, the intercalant within the graphite decomposes and volatilizes, causing the particles of intercalated graphite to expand in dimension as much as about 80 or more times its original volume in an accordion-like fashion in the "c" direction, i.e. in the direction perpendicular to the crystalline planes of the graphite. The exfoliated graphite particles are vermiform in appearance, and are therefore commonly referred to as worms. The worms may be compressed together into flexible sheets that, unlike the original graphite flakes, can be formed and cut into various shapes.

[0034] Graphite starting materials suitable for use in the present invention include highly graphitic carbonaceous materials capable of intercalating organic and inorganic acids as well as halogens and then expanding when exposed to heat. These highly graphitic carbonaceous materials most preferably have a degree of graphitization of about 1.0. As used in this disclosure, the term "degree of graphitization" refers to the value *g* according to the formula:

$$g = \frac{3.45 - d(002)}{0.095}$$

where *d*(002) is the spacing between the graphitic layers of the carbons in the crystal structure measured in Angstrom units. The spacing *d* between graphite layers is measured by standard X-ray diffraction techniques. The positions of diffraction peaks corresponding to the (002), (004) and (006) Miller Indices are measured, and standard least-squares techniques are employed to derive spacing which minimizes the total error for all of these peaks. Examples of highly

graphitic carbonaceous materials include natural graphites from various sources, as well as other carbonaceous materials such as graphite prepared by chemical vapor deposition, high temperature pyrolysis of polymers, or crystallization from molten metal solutions and the like. Natural graphite is most preferred.

5 [0035] The graphite starting materials used in the present invention may contain non-graphite components so long as the crystal structure of the starting materials maintains the required degree of graphitization and they are capable of exfoliation. Generally, any carbon-containing material, the crystal structure of which possesses the required degree of graphitization and which can be exfoliated, is suitable for use with the present invention. Such graphite preferably has a purity of at least about eighty weight percent. More preferably, the graphite employed for the present invention will have a purity of at least about 94%. In the most preferred embodiment, the graphite employed will have a purity of at least about 98%.

10 [0036] A common method for manufacturing graphite sheet is described by Shane *et al.* in U.S. Patent No. 3,404,061. In the typical practice of the Shane *et al.* method, natural graphite flakes are intercalated by dispersing the flakes in a solution containing *e.g.*, a mixture of nitric and sulfuric acid, advantageously at a level of about 20 to about 300 parts by weight of intercalant solution per 100 parts by weight of graphite flakes (pph). The intercalation solution contains oxidizing and other intercalating agents known in the art. Examples include those containing oxidizing agents and oxidizing mixtures, such as solutions containing nitric acid, potassium chlorate, chromic acid, potassium permanganate, potassium chromate, potassium dichromate, perchloric acid, and the like, or mixtures, such as for example, concentrated nitric acid and chlorate, chromic acid and phosphoric acid, sulfuric acid and nitric acid, or mixtures of a strong organic acid, *e.g.* trifluoroacetic acid, and a strong oxidizing agent soluble in the organic acid. Alternatively, an electric potential can be used to bring about oxidation of the graphite. Chemical species that can be introduced into the graphite crystal using electrolytic oxidation include sulfuric acid as well as other acids.

15 [0037] In a preferred embodiment, the intercalating agent is a solution of a mixture of sulfuric acid, or sulfuric acid and phosphoric acid, and an oxidizing agent, *i.e.* nitric acid, perchloric acid, chromic acid, potassium permanganate, hydrogen peroxide, iodic or periodic acids, or the like. Although less preferred, the intercalation solution may contain metal halides such as ferric chloride, and ferric chloride mixed with sulfuric acid, or a halide, such as bromine as a solution of bromine and sulfuric acid or bromine in an organic solvent.

20 [0038] The quantity of intercalation solution may range from about 20 to about 350 pph and more typically about 40 to about 160 pph. After the flakes are intercalated, any excess solution is drained from the flakes and the flakes are water-washed. Alternatively, the quantity of the intercalation solution may be limited to between about 10 and about 40 pph, which permits the washing step to be eliminated as taught and described in U.S. Patent No. 4,895,713.

25 [0039] The particles of graphite flake treated with intercalation solution can optionally be contacted, *e.g.* by blending, with a reducing organic agent selected from alcohols, sugars, aldehydes and esters which are reactive with the surface film of oxidizing intercalating solution at temperatures in the range of 25°C and 125°C. Suitable specific organic agents include hexadecanol, octadecanol, 1-octanol, 2-octanol, decylalcohol, 1, 10 decanediol, decylaldehyde, 1-propanol, 1,3 propanediol, ethyleneglycol, polypropylene glycol, dextrose, fructose, lactose, sucrose, potato starch, ethylene glycol monostearate, diethylene glycol dibenzoate, propylene glycol monostearate, glycerol monostearate, dimethyl oxylate, diethyl oxylate, methyl formate, ethyl formate, ascorbic acid and lignin-derived compounds, such as sodium lignosulfate. The amount of organic reducing agent is suitably from about 0.5 to 4% by weight of the particles of graphite flake.

30 [0040] The use of an expansion aid applied prior to, during or immediately after intercalation can also provide improvements. Among these improvements can be reduced exfoliation temperature and increased expanded volume (also referred to as "worm volume"). An expansion aid in this context will advantageously be an organic material sufficiently soluble in the intercalation solution to achieve an improvement in expansion. More narrowly, organic materials of this type that contain carbon, hydrogen and oxygen, preferably exclusively, may be employed. Carboxylic acids have been found especially effective. A suitable carboxylic acid useful as the expansion aid can be selected from aromatic, aliphatic or cycloaliphatic, straight chain or branched chain, saturated and unsaturated monocarboxylic acids, dicarboxylic acids and polycarboxylic acids which have at least 1 carbon atom, and preferably up to about 15 carbon atoms, which is soluble in the intercalation solution in amounts effective to provide a measurable improvement of one or more aspects of exfoliation. Suitable organic solvents can be employed to improve solubility of an organic expansion aid in the intercalation solution.

35 [0041] Representative examples of saturated aliphatic carboxylic acids are acids such as those of the formula H (CH₂)_nCOOH wherein n is a number of from 0 to about 5, including formic, acetic, propionic, butyric, pentanoic, hexanoic, and the like. In place of the carboxylic acids, the anhydrides or reactive carboxylic acid derivatives such as alkyl esters can also be employed. Representative of alkyl esters are methyl formate and ethyl formate. Sulfuric acid, nitric acid and other known aqueous intercalants have the ability to decompose formic acid, ultimately to water and carbon dioxide. Because of this, formic acid and other sensitive expansion aids are advantageously contacted with the graphite flake prior to immersion of the flake in aqueous intercalant. Representative of dicarboxylic acids are aliphatic dicarboxylic acids having 2-12 carbon atoms, in particular oxalic acid, fumaric acid, malonic acid, maleic acid, succinic acid, glutaric acid, adipic acid, 1,5-pentanedicarboxylic acid, 1,6-hexanedicarboxylic acid, 1,10-decanedicarboxylic acid, cyclohexane-

1,4-dicarboxylic acid and aromatic dicarboxylic acids such as phthalic acid or terephthalic acid. Representative of alkyl esters are dimethyl oxylate and diethyl oxylate. Representative of cycloaliphatic acids is cyclohexane carboxylic acid and of aromatic carboxylic acids are benzoic acid, naphthoic acid, anthranilic acid, p-aminobenzoic acid, salicylic acid, o-, m- and p-tolyl acids, methoxy and ethoxybenzoic acids, acetoacetamidobenzoic acids and acetamidobenzoic acids, phenylacetic acid and naphthoic acids. Representative of hydroxy aromatic acids are hydroxybenzoic acid, 3-hydroxy-1-naphthoic acid, 3-hydroxy-2-naphthoic acid, 4-hydroxy-2-naphthoic acid, 5-hydroxy-1-naphthoic acid, 5-hydroxy-2-naphthoic acid, 6-hydroxy-2-naphthoic acid and 7-hydroxy-2-naphthoic acid. Prominent among the polycarboxylic acids is citric acid.

[0042] The intercalation solution will be aqueous and will preferably contain an amount of expansion aid of from about 1 to 10%, the amount being effective to enhance exfoliation. In the embodiment wherein the expansion aid is contacted with the graphite flake prior to or after immersing in the aqueous intercalation solution, the expansion aid can be admixed with the graphite by suitable means, such as a V-blender, typically in an amount of from about 0.2% to about 10% by weight of the graphite flake.

[0043] After intercalating the graphite flake, and following the blending of the intercalant coated intercalated graphite flake with the organic reducing agent, the blend is exposed to temperatures in the range of 25° to 125°C to promote reaction of the reducing agent and intercalant coating. The heating period is up to about 20 hours, with shorter heating periods, e.g., at least about 10 minutes, for higher temperatures in the above-noted range. Times of one half hour or less, e.g., on the order of 10 to 25 minutes, can be employed at the higher temperatures.

[0044] The thusly treated particles of graphite are sometimes referred to as "particles of intercalated graphite." Upon exposure to high temperature, e.g. temperatures of at least about 160°C and especially about 700°C to 1000°C and higher, the particles of intercalated graphite expand as much as about 80 to 1000 or more times their original volume in an accordion-like fashion in the c-direction, i.e. in the direction perpendicular to the crystalline planes of the constituent graphite particles. The expanded, i.e. exfoliated, graphite particles are vermiform in appearance, and are therefore commonly referred to as worms. The worms may be compressed together into flexible sheets that, unlike the original graphite flakes, can be formed and cut into various shapes.

[0045] Flexible graphite sheet and foil are coherent, with good handling strength, and are suitably compressed, e.g. by roll pressing, to a thickness of about 0.075 mm to 3.75 mm and a typical density of about 0.1 to 1.5 grams per cubic centimeter (g/cm³). From about 1.5-30% by weight of ceramic additives can be blended with the intercalated graphite flakes as described in U.S. Patent No. 5,902,762 to provide enhanced resin impregnation in the final flexible graphite product. The additives include ceramic fiber particles having a length of about 0.15 to 1.5 millimeters. The width of the particles is suitably from about 0.04 to 0.004 mm. The ceramic fiber particles are non-reactive and non-adhering to graphite and are stable at temperatures up to about 1100°C, preferably about 1400°C or higher. Suitable ceramic fiber particles are formed of macerated quartz glass fibers, carbon and graphite fibers, zirconia, boron nitride, silicon carbide and magnesia fibers, naturally occurring mineral fibers such as calcium metasilicate fibers, calcium aluminum silicate fibers, aluminum oxide fibers and the like.

[0046] The above described methods for intercalating and exfoliating graphite flake may beneficially be augmented by a pretreatment of the graphite flake at graphitization temperatures, i.e. temperatures in the range of about 3000°C and above and by the inclusion in the intercalant of a lubricious additive, as described in International Patent WO03051772.

[0047] The pretreatment, or annealing, of the graphite flake results in significantly increased expansion (i.e., increase in expansion volume of up to 300% or greater) when the flake is subsequently subjected to intercalation and exfoliation. Indeed, desirably, the increase in expansion is at least about 50%, as compared to similar processing without the annealing step. The temperatures employed for the annealing step should not be significantly below 3000°C, because temperatures even 100°C lower result in substantially reduced expansion.

[0048] The annealing of the present invention is performed for a period of time sufficient to result in a flake having an enhanced degree of expansion upon intercalation and subsequent exfoliation. Typically the time required will be 1 hour or more, preferably 1 to 3 hours and will most advantageously proceed in an inert environment. For maximum beneficial results, the annealed graphite flake will also be subjected to other processes known in the art to enhance the degree expansion - namely intercalation in the presence of an organic reducing agent, an intercalation aid such as an organic acid, and a surfactant wash following intercalation. Moreover, for maximum beneficial results, the intercalation step may be repeated.

[0049] The annealing step of the instant invention may be performed in an induction furnace or other such apparatus as is known and appreciated in the art of graphitization; for the temperatures here employed, which are in the range of 3000°C, are at the high end of the range encountered in graphitization processes.

[0050] Because it has been observed that the worms produced using graphite subjected to pre-intercalation annealing can sometimes "clump" together, which can negatively impact area weight uniformity, an additive that assists in the formation of "free flowing" worms is highly desirable. The addition of a lubricious additive to the intercalation solution facilitates the more uniform distribution of the worms across the bed of a compression apparatus (such as the bed of a calender station conventionally used for compressing (or "calendering") graphite worms into flexible graphite sheet. The

resulting sheet therefore has higher area weight uniformity and greater tensile strength. The lubricious additive is preferably a long chain hydrocarbon, more preferably a hydrocarbon having at least about 10 carbons. Other organic compounds having long chain hydrocarbon groups, even if other functional groups are present, can also be employed.

5 **[0051]** More preferably, the lubricious additive is an oil, with a mineral oil being most preferred, especially considering the fact that mineral oils are less prone to rancidity and odors, which can be an important consideration for long term storage. It will be noted that certain of the expansion aids detailed above also meet the definition of a lubricious additive. When these materials are used as the expansion aid, it may not be necessary to include a separate lubricious additive in the intercalant.

10 **[0052]** The lubricious additive is present in the intercalant in an amount of at least about 1.4 pph, more preferably at least about 1.8 pph. Although the upper limit of the inclusion of lubricious additive is not as critical as the lower limit, there does not appear to be any significant additional advantage to including the lubricious additive at a level of greater than about 4 pph.

15 **[0053]** The thus treated particles of graphite are sometimes referred to as "particles of intercalated graphite." Upon exposure to high temperature, e.g. temperatures of at least about 160°C and especially about 700°C to 1200°C and higher, the particles of intercalated graphite expand as much as about 80 to 1000 or more times their original volume in an accordion-like fashion in the c-direction, i.e. in the direction perpendicular to the crystalline planes of the constituent graphite particles. The expanded, i.e. exfoliated, graphite particles are vermiform in appearance, and are therefore commonly referred to as worms. The worms may be compressed together into flexible sheets that, unlike the original graphite flakes, can be formed and cut into various shapes and provided with small transverse openings by deforming mechanical impact as hereinafter described.

20 **[0054]** Flexible graphite sheet and foil are coherent, with good handling strength, and are suitably compressed, e.g. by roll-pressing, to a thickness of about 0.075 mm to 3.75 mm and a typical density of about 0.1 to 1.5 grams per cubic centimeter (g/cc). From about 1.5-30% by weight of ceramic additives can be blended with the intercalated graphite flakes as described in U.S. Patent No. 5,902,762 to provide enhanced resin impregnation in the final flexible graphite product. The additives include ceramic fiber particles having a length of about 0.15 to 1.5 millimeters. The width of the particles is suitably from about 0.04 to 0.004 mm. The ceramic fiber particles are non-reactive and non-adhering to graphite and are stable at temperatures up to about 1100°C, preferably about 1400°C or higher. Suitable ceramic fiber particles are formed of macerated quartz glass fibers, carbon and graphite fibers, zirconia, boron nitride, silicon carbide and magnesia fibers, naturally occurring mineral fibers such as calcium metasilicate fibers, calcium aluminum silicate fibers, aluminum oxide fibers and the like.

25 **[0055]** The flexible graphite sheet can also, at times, be advantageously treated with resin and the absorbed resin, after curing, enhances the moisture resistance and handling strength, i.e. stiffness, of the flexible graphite sheet as well as "fixing" the morphology of the sheet. Suitable resin content is preferably at least about 5% by weight, more preferably about 10 to 35% by weight, and suitably up to about 60% by weight. Resins found especially useful in the practice of the present invention include acrylic-, epoxy- and phenolic-based resin systems, fluoro-based polymers, or mixtures thereof. Suitable epoxy resin systems include those based on diglycidyl ether of bisphenol A (DGEBA) and other multifunctional resin systems; phenolic resins that can be employed include resole and novolac phenolics. Optionally, the flexible graphite may be impregnated with fibers and/or salts in addition to the resin or in place of the resin. Additionally, reactive or non-reactive additives may be employed with the resin system to modify properties (such as tack, material flow, hydrophobicity, etc.).

30 **[0056]** Alternatively, the flexible graphite sheets of the present invention may utilize particles of reground flexible graphite sheets rather than freshly expanded worms, as discussed in International Patent WO02096615. The sheets may be newly formed sheet material, recycled sheet material, scrap sheet material, or any other suitable source.

35 **[0057]** Also the processes of the present invention may use a blend of virgin materials and recycled materials.

40 **[0058]** The source material for recycled materials may be sheets or trimmed portions of sheets that have been compression molded as described above, or sheets that have been compressed with, for example, pre-calendering rolls, but have not yet been impregnated with resin. Furthermore, the source material may be sheets or trimmed portions of sheets that have been impregnated with resin, but not yet cured, or sheets or trimmed portions of sheets that have been impregnated with resin and cured. The source material may also be recycled flexible graphite proton exchange membrane (PEM) fuel cell components such as flow field plates or electrodes. Each of the various sources of graphite may be used as is or blended with natural graphite flakes.

45 **[0059]** Once the source material of flexible graphite sheets is available, it can then be comminuted by known processes or devices, such as a jet mill, air mill, blender, etc. to produce particles. Preferably, a majority of the particles have a diameter such that they will pass through 20 U.S. mesh; more preferably a major portion (greater than about 20%, most preferably greater than about 50%) will not pass through 80 U.S. mesh. Most preferably the particles have a particle size of no greater than about 20 mesh. It may be desirable to cool the flexible graphite sheet when it is resin-impregnated as it is being comminuted to avoid heat damage to the resin system during the comminution process.

50 **[0060]** The size of the comminuted particles may be chosen so as to balance machinability and formability of the

graphite article with the thermal characteristics desired. Thus, smaller particles will result in a graphite article which is easier to machine and/or form, whereas larger particles will result in a graphite article having higher anisotropy, and, therefore, greater in-plane electrical and thermal conductivity.

5 [0061] If the source material has been resin impregnated, then preferably the resin is removed from the particles. Details of the resin removal are further described below.

[0062] Once the source material is comminuted, and any resin is removed, it is then re-expanded. The re-expansion may occur by using the intercalation and exfoliation process described above and those described in U.S. Patent No. 3,404,061 to Shane et al. and U.S. Patent No. 4,895,713 to Greinke et al.

10 [0063] Typically, after intercalation the particles are exfoliated by heating the intercalated particles in a furnace. During this exfoliation step, intercalated natural graphite flakes may be added to the recycled intercalated particles. Preferably, during the re-expansion step the particles are expanded to have a specific volume in the range of at least about 100 cc/g and up to about 350 cc/g or greater. Finally, after the re-expansion step, the re-expanded particles may be compressed into flexible sheets, as hereinafter described.

15 [0064] If the starting material has been impregnated with a resin, the resin should preferably be at least partially removed from the particles. This removal step should occur between the comminuting step and the re-expanding step.

[0065] In one embodiment, the removing step includes heating the resin containing regrind particles, such as over an open flame. More specifically, the impregnated resin may be heated to a temperature of at least about 250°C to effect resin removal. During this heating step care should be taken to avoid flashing of the resin decomposition products; this can be done by careful heating in air or by heating in an inert atmosphere. Preferably, the heating should be in the range

20 of from about 400°C to about 800°C for a time in the range of from at least about 10 and up to about 150 minutes or longer. [0066] Additionally, the resin removal step may result in increased tensile strength of the resulting article produced from the molding process as compared to a similar method in which the resin is not removed. The resin removal step may also be advantageous because during the expansion step (*i.e.*, intercalation and exfoliation), when the resin is mixed with the intercalation chemicals, it may in certain instances create toxic byproducts.

25 [0067] Thus, by removing the resin before the expansion step a superior product is obtained such as the increased strength characteristics discussed above. The increased strength characteristics are a result of in part because of increased expansion. With the resin present in the particles, expansion may be restricted

[0068] In addition to strength characteristics and environmental concerns, resin may be removed prior to intercalation in view of concerns about the resin possibly creating a run away exothermic reaction with the acid.

30 [0069] In view of the above, preferably a majority of the resin is removed. More preferably, greater than about 75% of the resin is removed. Most preferably, greater than 99% of the resin is removed.

[0070] Once the flexible graphite sheet is comminuted, it is formed into the desired shape and then cured (when resin impregnated) in the preferred embodiment. Alternatively, the sheet can be cured prior to being comminuted, although post-comminution cure is preferred.

35 [0071] The flexible graphite sheet can also, at times, be treated with resin and the absorbed resin, after curing, enhances the moisture resistance and handling strength, *i.e.* stiffness, of the flexible graphite sheet as well as "fixing" the morphology of the sheet. Suitable resin content is preferably less than about 60% by weight, more preferably less than about 35% by weight, and most preferably from about 4% to about 15% by weight. Resins found especially useful in the practice of the present invention include acrylic-, epoxy- and phenolic-based resin systems, or mixtures thereof. Suitable epoxy

40 resin systems include those based on diglycidyl ether or bisphenol A (DGEBA) and other multifunctional resin systems; phenolic resins that can be employed include resole and novolak phenolics. For the purposes of the present invention, however, resin impregnation, and the stiffness it provides, can be disadvantageous. [0072] Optionally, the flexible graphite sheet used to form the inventive thermal solution can be used as a laminate, with or without an adhesive between laminate layers. Non-graphite layers may be included in the laminate stack, although

45 this may necessitate the use of adhesives, which can be disadvantageous, as discussed above. Such non-graphite layers may include metals, plastics or other non-metals such as fiberglass or ceramics. [0073] As noted above, the thusly-formed sheets of compressed particles of exfoliated graphite are anisotropic in nature; that is, the thermal conductivity of the sheets is greater in the in-plane, or "a" directions, as opposed to the through-sheet, or "c" direction. In this way, the anisotropic nature of the graphite sheet directs the heat along the planar

50 direction of the thermal solution (*i.e.*, in the "a" direction along the graphite sheet). Such a sheet generally has a thermal conductivity in the in-plane direction of at least about 140, more preferably at least about 200, and most preferably at least about 250 W/m²K and in the through-plane direction of no greater than about 12, more preferably no greater than about 10, and most preferably no greater than about 6 W/m²K. Thus, the thermal solution has a thermal anisotropic ratio (that is, the ratio of in-plane thermal conductivity to through-plane thermal conductivity) of no less than about 10.

55 [0074] The values of thermal conductivity in the in-plane and through-plane directions of the laminate can be manipulated by altering the directional alignment of the graphene layers of the flexible graphite sheets used to form the thermal solution, including if being used to form a laminate, or by altering the directional alignment of the graphene layers of the laminate itself after it has been formed. In this way, the in-plane thermal conductivity of the thermal solution is increased,

while the through-plane thermal conductivity of the thermal solution is decreased, this resulting in an increase of the thermal anisotropic ratio.

5 [0075] One of the ways this directional alignment of the graphene layers can be achieved is by the application of pressure to the component flexible graphite sheets, either by calendaring the sheets (*i.e.*, through the application of shear force) or by die pressing or reciprocal platen pressing (*i.e.*, through the application of compaction), with calendaring more effective at producing directional alignment. For instance, by calendaring the sheets to a density of 1.7 g/cc, as opposed to 1.1 g/cc, the in-plane thermal conductivity is increased from about 240 W/m²K to about 450 W/m²K or higher, and the through-plane thermal conductivity is decreased proportionally, thus increasing the thermal anisotropic ratio of the individual sheets and, by extension, any laminate formed therefrom.

10 [0076] Alternatively, if a laminate is formed, the directional alignment of the graphene layers which make up the laminate in gross is increased, such as by the application of pressure, resulting in a density greater than the starting density of the component flexible graphite sheets that make up the laminate. Indeed, a final density for the laminated article of at least about 1.4 g/cc, more preferably at least about 1.6 g/cc, and up to about 2.0 g/cc can be obtained in this manner. The pressure can be applied by conventional means, such as by die pressing or calendaring. Pressures of at least about 60 megapascals (MPa) are preferred, with pressures of at least about 550 MPa, and more preferably at least about 700 MPa, needed to achieve densities as high as 2.0 g/cc.

15 [0077] Surprisingly, increasing the directional alignment of the graphene layers can increase the in-plane thermal conductivity of the graphite laminate to conductivities which are equal to or even greater than that of pure copper, while the density remains a fraction of that of pure copper. Additionally, the resulting aligned laminate also exhibits increased strength, as compared to a non-"aligned" laminate.

20 [0078] Referring now to the drawings, and particularly to Fig. 1, an embodiment of the thermal solution of the present invention is shown and generally designated by the numeral 10. Thermal solution 10 comprises a sheet of compressed particles of exfoliated graphite, having two major surfaces, denoted 10a and 10b. One of major surfaces 10a or 10b of thermal solution 10 is sized to be positioned in operative contact with a heat source, denoted 100, such as an electronic component like a hard drive of a laptop computer or a chipset of a cellular phone, such that heat generated by heat source 100 dissipates into thermal solution 10. The area of the major surface 10a or 10b which is in contact with heat source 100 is greater than the area of contact with heat source 100, so that thermal solution 10 spreads the heat from heat source 100.

25 [0079] Furthermore, one of the major surfaces 10a or 10b of thermal solution 10 can be in operative contact with a heat dissipation device 110, such as a heat sink, heat pipe, heat plate, etc. Heat dissipation device 110 can contact thermal solution 10 on either the same major surface 10a or 10b as heat source 100. Because of the anisotropic nature of thermal solution 10, heat from heat source 100 is thereby spread to heat dissipation device 110 to thus dissipate the heat generated. In this way thermal solution acts to as a heat spreader to spread the heat generated by heat source 100, including spreading the heat to heat dissipation device 110.

30 [0080] Because of the relatively high thermal anisotropic ratio of thermal solution 10, however, heat from heat source 100 is not effectively transmitted through the plane of thermal solution 10 from the one of major surfaces 10a or 10b in operative contact with heat source 100 to the other. Therefore, heat is not effectively transmitted to an external surface of the device in which heat source 10 is located (such as a laptop computer or a cellular phone), reducing the temperature of such external surface (by as much as 10°C or more in some cases), when thermal solution 10 is disposed between heat source 10 and the external surface.

35 [0081] Likewise, heat is not effectively transmitted to another component within the device in which heat source 10 is located (such as a laptop computer or a cellular phone), reducing the temperature to which such other component is exposed, when thermal solution 10 is disposed between heat source 10 and the other component.

40 [0082] Figs. 2a and 2b illustrate the positioning of thermal solution 10 in a laptop computer 120 to accomplish the advantageous aspect of the inventive design. As seen in Fig. 2a, laptop computer 120 may have, under its protective case, a number of components, including one or more heat generating components, denoted 122. In addition, laptop computer 120 may have heat dissipation devices, such as a heat sink 124. Because of space limitations, though, it is not always possible to array heat sink 124 adjacent heat generating components 122.

45 [0083] in Fig. 2b, however, thermal solution 10 is positioned in laptop computer 120 so as to overlay both heat generating component 122 and heat sink 124. Therefore, heat can now flow from heat generating component 122 to heat sink 124 for dissipation. Moreover, because of the relatively low through-plane thermal conductivity of thermal solution 10, heat does not flow through thermal solution 10 effectively, preventing overheating of the environment shielded by thermal solution 10. This would not be possible if a more isotropic material such as copper or aluminum were used.

50 [0084] Moreover because of the flexible nature of thermal solution 10, thermal solution 10 can follow the contours of the components within laptop computer 120, as illustrated in Fig. 2b, thus not requiring very much additional space. Again, a more rigid material like copper or aluminum would not as easily be able to do the same.

55 [0085] If desired, a protective coating 20 can be applied to thermal solution 10, as illustrated in Fig. 3, to improve the handleability and mechanical robustness of thermal solution 10, and to forestall the possibility of graphite particles flaking

from, or otherwise being separated from, thermal solution 10. Protective coating 20 also advantageously effectively isolates thermal interface 10, to avoid electrical interference engendered by the inclusion of an electrically conductive material (graphite) in an electronic device. Moreover, use of protective coating 20 with a relatively low thermal conductivity will increase the thermal shielding effect of thermal solution 10.

5 [0086] Protective coating 20 can comprise any suitable material sufficient to prevent the flaking of the graphite material and/or to electrically isolate the graphite, such as a thermoplastic material like polyethylene, a polyester or a polyimide.

[0087] Thermal solution 10, having protective coating 20 thereon, can be manufactured by several different processes. For instance, once the flexible graphite sheet is cut to size and shape to form thermal solution 10, the material from which protective coating 20 is formed can be coated on the individual thermal thermal solution 10 to form a protective flaking boundary about thermal solution 10, as illustrated in Fig. 3. To that end, protective coating 20 can be applied by various coating methods familiar to the skilled artisan, such as spray coating, roller coating and hot laminating press. Protective coating 20 can also be applied by mechanical mapping and lamination.

10 [0088] Generally, the coating process adheres protective coating 20 to thermal solution 10 with sufficient strength for most applications. However, if desired, or for relatively non-adhesive protective coatings 20, such as Mylar® polyester materials and Kapton polyimide materials (both commercially available from E.I. du Pont de Nemours and Company of Wilmington, Delaware), a layer of adhesive may be applied between thermal solution 10 and protective coating 20. Suitable adhesives are those which can facilitate the adhesion of protective coating 20 to thermal solution 10, such as acrylic or latex adhesives.

15 [0089] In another embodiment, also illustrated in Fig. 3, a material 130 to improve handleability and mechanical robustness of thermal solution 10. and to facilitate thermal transfer between heat source 100 and thermal solution 10 can be interposed between thermal solution 10 and heat source 100. One such material is a metal like copper or aluminum. Other thermal interface materials, such as those taught in International Patent WO03057475 can also be employed.

20 [0090] Thus, by use of the present invention, thermal shielding and thermal spreading of the heat generated by component of an electronic device, in order to dissipate the heat as well as reduce the "touch temperature" of the device and the heat transmitted to adjacent components. These functions cannot be accomplished by more traditional heat dissipation materials like copper or aluminum which, because of their isotropic natures, would do little to reduce touch temperature or the heat transmitted to adjacent components. Insulating materials which could be used to reduce touch temperature and the heat transmitted to adjacent components would not dissipate heat and result in heat buildup about the heat source component.

25 [0091] The thermal dissipation and shielding system for an electronic device in accordance with the invention will now be more particularly described with reference to the following examples

Example 1

35 [0092] A notebook computer having the hard drive of the system under the left palm rest, as is conventional, is obtained. The hard drive of the computer is exercised by running an AVI file and the external temperature of the case at the left palm-rest, touch pad and right palm-rest is monitored using an infra-red camera, with the results recorded. The computer case is removed and a thermal solution formed of a flexible graphite sheet having two major surfaces is positioned such that one of its major surfaces is in operative contact with the hard drive such that it is interposed between the hard drive and the case of the computer. The thermal solution was 0.5 mm in thickness and had a thermal conductivity in the X-Y plane of 260 W/m²K, and had a coating of 0.013 mm polyethylene terephthalate film on each side. The notebook was then tested in an identical manner as previously, and the results for both tests recorded in Table 1.

Table 1.

	Left Palm-Rest	Touch Pad	Right Palm-Rest	Δ T Left and Right Palm-Rest
Without Thermal Solution	12.4	9.7	3.0	9.4
With Thermal Solution	8	7.7	4.9	3.1

45 [0093] As will be noted, the use of the inventive thermal solution results in the temperature at the left palm-rest being significantly reduced and the difference in temperature between the left and right palm-rests being significantly improved.

55 Example 2

[0094] The cooling of a graphics processor in a notebook computer via a carbon composite case as a heat sink in combination with the inventive thermal solution is demonstrated. In this example, a 0.25 mm thick thermal solution formed

of a flexible graphite sheet having two major surfaces and having a thermal conductivity in the X-Y plane of 260 W/m²K is adhesively attached to the lowercase of a notebook computer. A compressible pad is located underneath the thermal solution, in alignment with the graphics processor, in order to increase the contact pressure and optimize the thermal resistance between the processor and the thermal solution. As a result, the heat from the processor is effectively transferred into the thermal solution, which effectively spreads the heat and transfers it into the carbon case of the notebook computer. The result is a dramatic reduction in the chip operating temperature of the graphics processor as well as the avoidance of a small "hot spot" on the case. In this instance the thermal solution conveys the processor heat to the carbon case over an area significantly larger (~70 cm²) than the chip "foot print" (~5 cm²), which is not possible with other thermal spreader or interface materials.

Example 3

[0095] A similar approach was used for cooling of the Intel Pentium M 1 GHz microprocessor. In this example, the heat generated by CPU is transferred into the upper portion of the carbon case above the keypad region. A 0.25 mm thick thermal solution formed of a flexible graphite sheet having two major surfaces and having a thermal conductivity in the X-Y plane of 260 W/m²K is attached to the case and in good contact with Pentium M processing chip. The result was a chip operating temperature of only 60°C, compared to greater than 77°C when no SpreaderShield component is utilized.

[0096] The invention thus being described, it will be obvious that it may be varied in many ways. Such variations are not to be regarded as a departure from the scope of the present invention and all such modifications as would be obvious to one skilled in the art are intended to be included within the scope of the following claims.

Claims

1. A thermal dissipation and shielding system, comprising:

an electronic device comprising a first component which comprises a heat source, wherein the first component transmits heat towards an external surface of the electronic device;
a second component located within the device to which the first component transmits heat;
a thermal solution comprising two major surfaces, the thermal solution positioned such that one of its major surfaces is in operative contact with the first component such that it is interposed between the first component and the external surface of the electronic device to which the first component transmits heat, wherein the thermal solution dissipates heat from the first component and shields the external surface from heat from the first component without effectively transmitting heat to the second component in the device, wherein the thermal solution comprises at least one sheet of flexible graphite following the contours of the components within the device.

2. The system of claim 1, wherein the electronic device is a laptop computer (120) and the external surface comprises a portion of the laptop computer case.

3. The system of claim 1 or claim 2, wherein the electronic device (120) further comprises a heat dissipation device (110) positioned in a location not directly adjacent to the first component (122) and further wherein one of the major surfaces (10a) of the thermal solution (10) is in operative contact with the heat dissipation device.

4. The system of claim 3, wherein the heat dissipation device (110) comprises a heat sink, a heat pipe, a heat plate or any combination thereof.

5. The system of any one of claims 1 to 4, wherein the thermal solution (10) has an in-plane thermal conductivity of at least about 140 W/m °K.

6. The system of any one of claims 1 to 5, wherein the thermal solution (10) has a through-plane thermal conductivity of no greater than about 12 W/m °K.

7. The system of any one of claims 1 to 6, wherein the thermal solution (10) further comprises a protective coating (20) thereon.

8. The system of claim 7, wherein the protective coating (20) has a thermal conductivity less than the through-plane

thermal conductivity of the at least one sheet of flexible graphite.

9. The system of any one of claims 1 to 8 wherein a thermal transfer material is positioned between the thermal solution (10) and the first component (122).

10. The system of claim 9 wherein the thermal transfer material comprises a metal or a thermal interface.

Patentansprüche

1. Wärmeableitungs- und -abschirmungssystem, umfassend:

eine elektronische Vorrichtung umfassend eine erste Komponente, die eine Wärmequelle umfasst, wobei die erste Komponente Wärme auf eine äußere Oberfläche der elektronischen Vorrichtung überträgt; eine zweite Komponente, die sich innerhalb der Vorrichtung befindet, an welche die erste Komponente Wärme überträgt;

eine thermische Lösung, die zwei Hauptoberflächen umfasst, wobei die thermische Lösung so angeordnet ist, dass eine ihrer Hauptoberflächen in operativem Kontakt mit der ersten Komponente steht, so dass sie zwischen der ersten Komponente und der äußeren Oberfläche der elektronischen Vorrichtung, an welche die erste Komponente Wärme überträgt, angeordnet ist,

wobei die thermische Lösung Wärme von der ersten Komponente ableitet und die äußere Oberfläche vor Wärme von der ersten Komponente abschirmt, ohne effektiv Wärme an die zweite Komponente in der Vorrichtung zu übertragen,

wobei die thermische Lösung zumindest einen Bogen aus flexiblem Graphit umfasst, der den Konturen der Komponenten innerhalb der Vorrichtung folgt.

2. System nach Anspruch 1, wobei die elektronische Vorrichtung Laptopcomputer (120) ist, und die äußere Oberfläche einen Abschnitt des Gehäuses des Laptopcomputers umfasst.

3. System nach Anspruch 1 oder Anspruch 2, wobei die elektronische Vorrichtung (120) des Weiteren eine Wärmeableitungsvorrichtung (110) umfasst, die in einer Position nicht direkt benachbart zu der ersten Komponente (122) positioniert ist, und wobei des Weiteren eine der Hauptoberflächen (10a) der thermischen Lösung (10) in operativem Kontakt mit der Wärmeableitungsvorrichtung steht.

4. System nach Anspruch 10, wobei die Wärmeableitungsvorrichtung (110) einen Kühlkörper, ein Wärmerohr, eine Wärmeplatte oder eine beliebige Kombination davon umfasst.

5. System nach einem der Ansprüche 1 bis 4, wobei die thermische Lösung (10) eine thermische Leitfähigkeit in der Ebene von zumindest etwa $140 \text{ W/m}^2\text{K}$ aufweist.

6. System nach einem der Ansprüche 1 bis 5, wobei die thermische Lösung (10) eine thermische Leitfähigkeit quer zur Ebene von nicht mehr als etwa $12 \text{ W/m}^2\text{K}$ aufweist.

7. System nach einem der Ansprüche 1 bis 6, wobei die thermische Lösung (10) ferner eine Schutzbeschichtung (20) aufweist.

8. System nach Anspruch 10, wobei die Schutzbeschichtung (20) eine thermische Leitfähigkeit aufweist, die geringer ist als die thermische Leitfähigkeit quer zur Ebene des zumindest einen Bogens aus flexiblem Graphit.

9. System nach einem der Ansprüche 1 bis 8, wobei ein Wärmetransfermaterial zwischen der thermischen Lösung (10) und der ersten Komponente (122) positioniert ist.

10. System nach Anspruch 9, wobei das Wärmetransfermaterial ein Metall oder eine Wärmeschnittstelle umfasst.

Revendications

1. Système de protection et de dissipation thermique, comprenant :

EP 2 259 164 B1

un dispositif électronique comprenant un premier composant qui comprend une source de chaleur, où le premier composant transmet de la chaleur vers une surface externe du dispositif électronique ;
un deuxième composant situé à l'intérieur du dispositif auquel le premier composant transmet de la chaleur ;
une solution thermique comprenant deux surfaces principales, la solution thermique étant positionnée de sorte que l'une de ses surfaces principales soit en contact fonctionnel avec le premier composant, de sorte qu'elle soit interposée entre le premier composant et la surface externe du dispositif électronique auquel le premier composant transmet de la chaleur,
dans lequel la solution thermique dissipe de la chaleur provenant du premier composant et protège la surface externe contre la chaleur provenant du premier composant sans transmettre efficacement de la chaleur au deuxième composant dans le dispositif,
dans lequel la solution thermique comprend au moins une feuille de graphite flexible suivant les contours des composants dans le dispositif.

5

10

15

20

25

30

35

40

45

50

55

2. Système de la revendication 1, dans lequel le dispositif électronique est un ordinateur portable (120) et la surface externe comprend une partie du boîtier de l'ordinateur portable.
3. Système de la revendication 1 ou 2, dans lequel le dispositif électronique (120) comprend en outre un dispositif de dissipation de chaleur (110) positionné dans un emplacement qui n'est pas directement adjacent au premier composant (122) et dans lequel en outre l'une des surfaces principales (10a) de la solution thermique (10) est en contact fonctionnel avec le dispositif de dissipation de chaleur.
4. Système de la revendication 3, dans lequel le dispositif de dissipation de chaleur (110) comprend un dissipateur de chaleur, un caloduc, une plaque thermique ou toute combinaison de ceux-ci.
5. Système de l'une quelconque des revendications 1 à 4, dans lequel la solution thermique (10) a une conductivité thermique dans le plan d'au moins environ $140 \text{ W/m}^\circ \text{ K}$.
6. Système de l'une quelconque des revendications 1 à 5, dans lequel la solution thermique (10) a une conductivité thermique à travers le plan de pas plus d'environ $12 \text{ W/m}^\circ \text{ K}$.
7. Système de l'une quelconque des revendications 1 à 6, dans lequel la solution thermique (10) comprend en outre un revêtement protecteur (20) sur celle-ci.
8. Système de la revendication 7, dans lequel le revêtement protecteur (20) a une conductivité thermique inférieure à la conductivité thermique à travers le plan de l'au moins une feuille de graphite flexible.
9. Système de l'une quelconque des revendications 1 à 8, dans lequel un matériau de transfert thermique est positionné entre la solution thermique (10) et le premier composant (122).
10. Système de la revendication 9, dans lequel le matériau de transfert thermique comprend un métal ou une interface thermique.

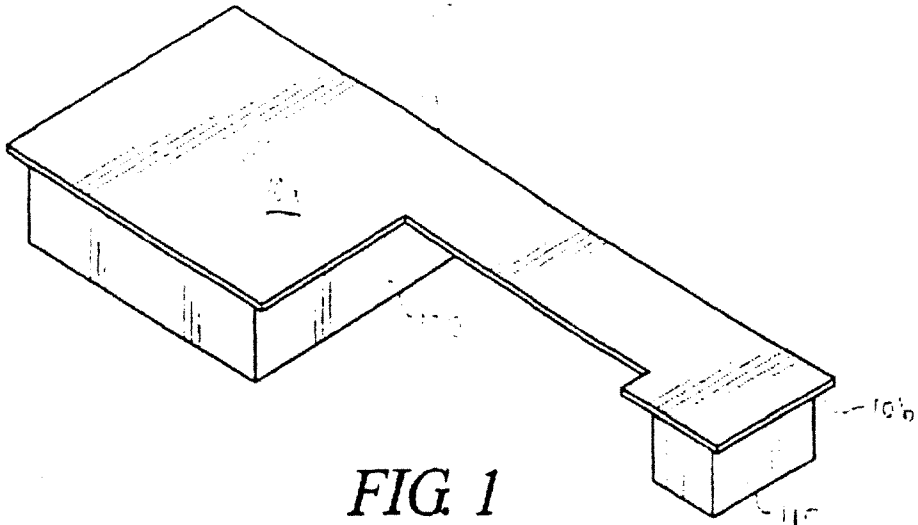

FIG. 1

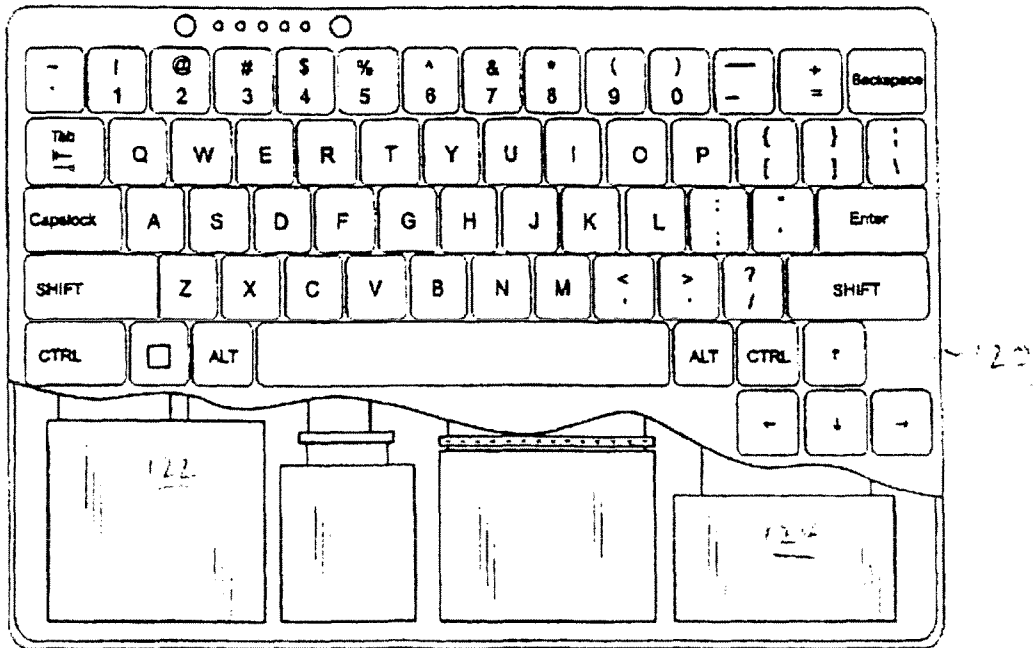

FIG. 2A

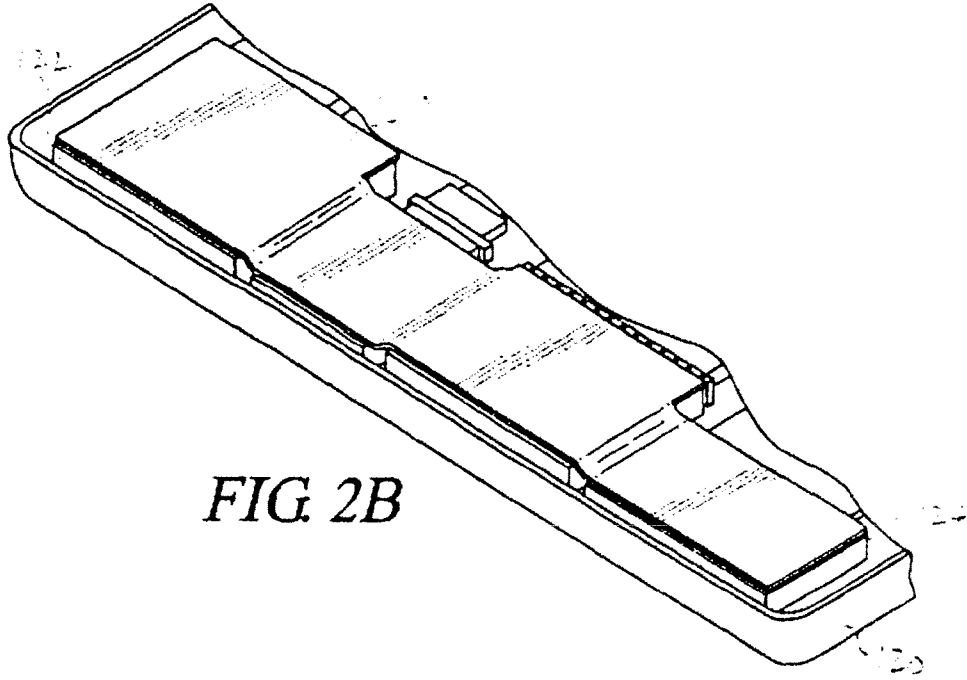

FIG. 2B

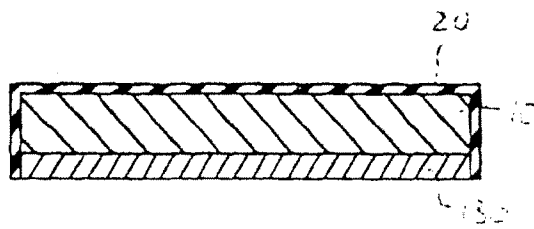

FIG. 3

REFERENCES CITED IN THE DESCRIPTION

This list of references cited by the applicant is for the reader's convenience only. It does not form part of the European patent document. Even though great care has been taken in compiling the references, errors or omissions cannot be excluded and the EPO disclaims all liability in this regard.

Patent documents cited in the description

- US 6245400 B [0013]
- US 6482520 B [0013]
- US 6503626 B [0013]
- US 6538892 B [0013]
- EP 2259164 A [0015]
- WO 03001133 A [0016]
- US 5930115 A [0017]
- WO 03057475 A [0022] [0089]
- US 3404061 A [0036] [0062]
- US 4895713 A [0038] [0062]
- US 5902762 A [0045] [0054]
- WO 03051772 A [0046]
- WO 02096615 A [0056]

HŰTÉSI MEGOLDÁS ELEKTRONIKUS ESZKÖZÖKHÖZ

Szabadalmi igénypontok

5

1. Hőelvezető és -szigetelő rendszer, amely magában foglal:

egy hőforrással rendelkező első alkatrészt tartalmazó elektronikus eszközt, ahol az első alkatrész hőt továbbít az elektronikus eszköz külső felülete felé;

10

az eszköz belsejében elhelyezkedő második alkatrészt, amely irányába az első alkatrész hőt továbbít;

egy hőkezelési megoldást, amely két fő felülettel rendelkezik, a hőkezelési megoldás úgy helyezkedik el, hogy az egyik fő felülete üzemszerűen kapcsolódik az első alkatrészhez úgy, hogy az első alkatrész és az elektronikus eszköz külső felülete között helyezkedik el, amely felé az első alkatrész hőt továbbít,

15

és ahol a hőkezelési megoldás elvezeti a hőt az első alkatrésztől, miközben elszigeteli a külső felületet az első alkatrész által sugárzott hőtől anélkül, hogy ténylegesen átvezetné a hőt az eszköz belsejében elhelyezkedő második alkatrész felé,

és ahol a hűtési megoldás tartalmaz legalább egy rugalmas grafitlapot, amely követi az eszköz belsejében elhelyezkedő alkatrészek körvonalát,

20

2. Az 1. igénypont által leírt rendszer, ahol az elektronikus eszköz egy laptop (120) és a külső felület magában foglalja a laptop burkolatának egy részét.

25

3. Az 1. vagy 2. igénypont által leírt rendszer, ahol az elektronikus eszköz (120) tartalmaz továbbá egy hőelvezető eszközt (110), amely nem közvetlenül az első alkatrészhez (122) kapcsolatosan helyezkedik el, és ahol továbbá a hőkezelési megoldás (10) fő felületeinek (10a) egyike üzemszerűen kapcsolódik a hőelvezető eszközhöz.

30

4. A 3. igénypont által leírt rendszer, ahol a hőelvezető eszköz (110) hűtőborda, hőcső, hűtőrács vagy ezek bármilyen kombinációja.

5. Az 1–4. igénypontok bármelyike által leírt rendszer, ahol a hőkezelési megoldás (10) legalább $140 \text{ W/m}^2\text{K}$ síkbeli hővezetőképességgel rendelkezik.



6. Az 1–5. igénypontok bármelyike által leírt rendszer, ahol a hőkezelési megoldás (10) legfeljebb $12 \text{ W/m}^2\text{K}$ síkra merőleges (átütési) hővezetőképességgel rendelkezik.

5 7. Az 1–6. igénypontok bármelyike által leírt rendszer, ahol a hűtési megoldás (10) tartalmaz továbbá egy védőbevonatot (20).

8. A 7. igénypont által leírt rendszer, ahol a védőbevonat (20) hővezetőképessége kisebb, mint a rugalmas grafit legalább egyik lapjának felületre merőleges (átütési) hővezetőképessége.

10

9. Az 1–8. igénypontok bármelyike által leírt rendszer, ahol a hővezető anyag a hőkezelési megoldás (10) és az első alkatrész (122) között helyezkedik el.

15

10. A 9. igénypont által leírt rendszer, ahol a hővezető anyag fém vagy termikus interfésszel rendelkezik.